

Los Angeles Department of Water and Power Energy Storage Development Plan



Grid Planning and Development
System Studies and Research Group

September 2, 2014

This space is intentionally left blank

Table of Contents:

Executive Summary	1
A. Background.....	1
B. Scope and Objectives.....	1
C. Energy Storage Targets.....	1
1. Overview and Policy	3
A. Purpose.....	3
B. Background.....	3
C. ES Regulation, Policy, and Legislative Impacts.....	5
2. Scope & Objectives	5
A. Energy Storage System Development Strategy	6
B. Energy Storage System Target Development Schedule	6
3. Description of Existing and Eligible Energy Storage System.....	7
A. Existing Energy Storage Systems	7
1. Large Pump Hydroelectric Plant (Castaic)	7
2. Thermal Energy Storage (TES) System.....	8
B. Eligible Energy Storage Systems.....	9
1. Energy Storage Systems Eligibility Criteria.....	9
2. Castaic Hydroelectric Power Plant Unit 1	10
3. Approved Thermal Energy Storage Project.....	10
4. Pilot Energy Storage Systems.....	11
4. Energy Storage System Evaluation Methodology	12
A. Selected Location Energy Storage Evaluation.....	13
1. Generation Thermal Energy Storage Solutions	13
2. Transmission Connected Energy Storage	14
3. Distribution Connected Energy Storage	16
4. Customer Connected Energy Storage Solutions	18
B. Whole Power System Energy Storage Evaluation.....	19
5. ESS Summary of Targets.....	22
6. Procurement Mechanism	23
A. Utility – Owned.....	23
B. Customer Incentive Programs.....	23
C. Collaborative Ownership	24
7. Rate Recovery	24

Appendices

- 1. Board Approved Resolution No. 012168 AB2514 Initiation**
- 2. Board Approved Resolution No. 015033 for Energy Storage Target Adoption**
- 3. Energy Storage Application Matrix**
- 4. Energy Storage Cost Effectiveness & Viability by Black & Veatch Corporation**
- 5. Energy Storage Distribution Impact and Value Analysis by EPRI**
- 6. Maximum Renewable Energy Penetration Report**
- 7. Maximum Distribution Renewable Penetration Study Scope of Work**
- 8. Maximum Generation Renewable Penetration Study Scope of Work**
- 9. SCPPA Request for Proposals for Renewable Energy and Energy Storage Projects**

Executive Summary

A. Background

On February 7, 2012, the LADWP's Board of Commissioners (Board) initiated a process by directing LADWP to determine appropriate targets, if any, for LADWP to procure viable and cost-effective Energy Storage System (ESS) by December 31, 2016 and December 31, 2021 pursuant to AB 2514 which became effective on January 1, 2011. In addition, LADWP shall report back to the Board prior to October 1, 2014, regarding potential procurement targets, if any, for LADWP to procure technologically viable and cost-effective ESS, at which time the Board may determine whether it is appropriate to adopt such targets.

B. Scope and Objectives

To conform to AB 2514 Requirements, LADWP has developed an analytical framework from which energy storage targets will be deduced which includes an evaluation of existing eligible energy storage systems and two energy storage procurement target development approaches. The first approach referred to as "Selected Location Energy Storage Evaluation" identifies specific location in power system where ESS may be the most useful and will be used to set ESS procurement targets for 2016, if any, and preliminary ESS procurement targets for 2021. To accomplish this approach, LADWP contracted with Black and Veatch, Inc. (B&V), Electric Power Research Institute (EPRI), and consulted with Southern California Public Power Authority (SCPPA) subject matter experts. The second approach referred to as "Whole Power System Energy Storage Evaluation", will be used to refine the ESS procurement target for 2021, and investigate whether ESS can be integrated at all levels of power system namely, generation, transmission, distribution, and behind-the-meter for the purposes of (i) integrating renewable energy, (ii) reducing peak load demand, (iii), deferring power system upgrades, and (iv) improving the overall system reliability. To accomplish this approach, LADWP is in the process of issuing two study task scopes to third parties.

C. Energy Storage Targets

Study and Preliminary Analysis Findings

Selected Location Energy Storage Evaluation Findings

- Studies performed under this category indicate that there is no additional ESS need in LADWP system that could be used for the 2016 ESS procurement target.
- Findings from the B&V study indicate that Battery Energy Storage Systems (BESS) are cost-effective if used to provide regulation service for each large-scale solar project namely, Beacon and Q09 Solar Projects. For that reason, Beacon and Q09 Solar Projects are recommended for a feasibility study.
- Findings from the EPRI study which only evaluates one 34.5kV circuit, suggest that a small BESS is not cost-effective. Although it is not cost-effective for the selected circuit, LADWP anticipates that ESS might be viable for other circuits under consideration in the Whole

Power System Energy Storage Evaluation. For that reason, a moderate size of BESS is recommended for further study.

- Preliminary assessment by LADWP indicates that Generation TES if installed at Valley Generating Station is the most cost-effective ESS (see Table 9). For that reason, Valley Generating Station is recommended for a feasibility study.
- Preliminary assessment by LADWP shows that an incentive program for distributed Thermal Energy Storage (TES) capped at \$750/kW of shifted demand capacity is cost-effective ESS (see Table 10). For that reason, distributed TES is recommended for a feasibility study.

Whole System Energy Storage Evaluation Findings

- All studies under this category are still pending. Once completed, viable and cost-effective ESS identified from study findings will proceed to a feasibility study. LADWP anticipates completing studies under this category no later than the end of 2015.

A summary of the LADWP energy storage targets for procurement in 2016 and 2021 is found in Table 1 below:

Table 1: Procurement targets to be established by the Board

CONNECTION LEVEL	PROPOSED TARGETS					
	2016 TARGETS			2021 TARGETS		
	Project Name	Energy Storage Type	Capacity	Project Name	Energy Storage Type	Capacity
GENERATION	Castaic	Pump Storage Hydro	21 MW	Valley Generating Station	Thermal Energy Storage	60 MW
		Sub-Total	21 MW		Sub-Total	60 MW
TRANSMISSION	None			Beacon Solar	Battery Energy Storage System	30 MW
				Q09 Solar	Battery Energy Storage System	20 MW
					Sub-Total	50 MW
DISTRIBUTION	None			Distribution Circuit	Battery Energy Storage System	4MW
					Sub-Total	4 MW
CUSTOMER	LAX	Thermal Energy Storage	3 MW	Distributed Energy Storage System	Thermal Energy Storage	40 MW
	Garage of Future	Battery Energy Storage System	0.05MW			
	La Kretz	Battery Energy Storage System	0.025 MW			
		Sub-Total	3.08 MW			
	TOTAL	24.08 MW		TOTAL	154 MW	

Outputs from all feasibility studies described above will be used to revise the LADWP ESS target for procurement in 2021 in accordance with AB 2514. LADWP anticipates completing all feasibility studies no later than December 2017. The purpose of feasibility study is to evaluate whether proposed ESS projects from studies recommendations are technically and environmentally feasible (electrical, spatial, environmental constraints and impact assessments, and incentive program survey) and achievable within the estimated cost. It may take two or more years to complete the feasibility studies before ESS can be procured. For that reason, a project that is

deemed viable and cost-effective, but recommended for a feasibility study will be included in the 2021 ESS procurement target. Otherwise, a project will be part of the 2016 targets based on its completed feasibility study.

LADWP ESS Procurement Target assessment and methodology along with completed, pending study task scopes, and findings are compiled in the Los Angeles Department of Water and Power Energy Storage Development Plan attached hereto.

1. Overview and Policy

A. Purpose

AB 2514 requires that a Publicly Owned Utility (POU) governing board set its own economically viable ESS targets for procurement in 2016 and 2021 and that any ESS procurement targets and policies that may be adopted by the governing board, and any modifications made to those targets as a result of the board's reevaluation be reported to the California Energy Commission (CEC). The Board has directed LADWP to determine appropriate targets, if any, for LADWP to procure. Viable and cost-effective ESS are described herein in this Report.

This report presents existing and eligible ESS, and examines the cost and benefit of various ESSs for LADWP applications connected to generation, transmission, distribution, and behind-the-meter. Pursuant to AB2514, LADWP has determined energy storage procurement to be achieved by a first target date of December 31, 2016, and a second target date of December 31, 2021. Various studies are included to substantiate the energy storage targets using an analytical framework to determine the cost effectiveness and viability of these targets.

B. Background

On September 29, 2010, the Governor signed Assembly Bill (AB) 2514 (Skinner, statutes of 2010). This legislation is aimed at encouraging electric utilities to assess the appropriate levels of energy storage that may be cost-effectively implemented. Accordingly, pursuant to Public Utilities Code Section 2835(b), each publicly owned electric utility is directed to initiate a process to determine appropriate targets, if any, for the utility to procure viable and cost-effective energy storage systems. If it is determined that there is an appropriate level of viable and cost-effective energy storage systems that can be achieved by December 31, 2016, and a second target by December 31, 2021, the publicly owned utility shall adopt the procurement targets by October 1, 2014 as shown in the timeline Figure 1 below.

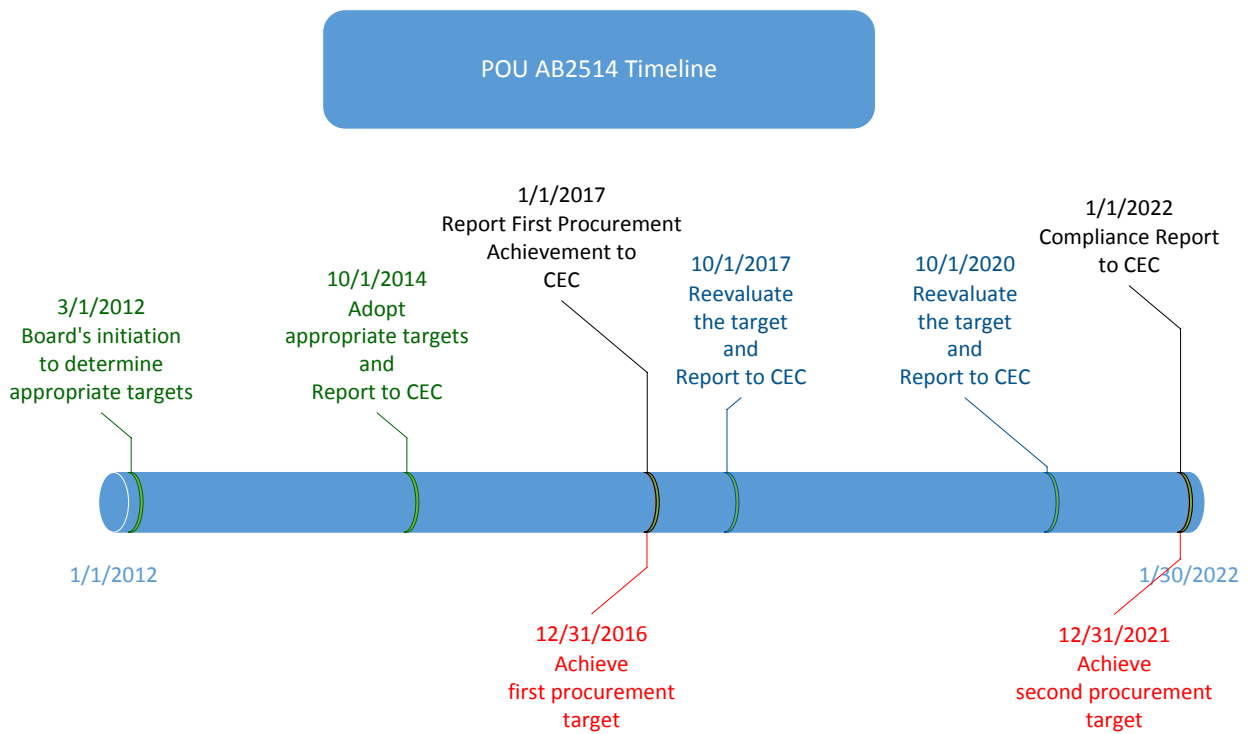

Figure 1: POU AB2514 Timeline

Under this law, the California Energy Commission (CEC) was given the responsibility to review the procurement targets and policies that are developed and adopted by publicly-owned utilities (POUs) to ensure that the targets and policies include and reflect the procurement of cost-effective and viable energy storage systems.

The law identifies specific deadlines for POU's compliance within the statute. In summary:

- 1) POU's are responsible to evaluate the cost-effectiveness and viability of energy storage systems in their electric systems. Additionally, POU's may also consider various policies to encourage the cost-effective deployment of energy storage systems. The initial evaluation(s) is (are) to occur by October 1, 2014.
- 2) With this responsibility, POU's also have the authority and discretion to deem any, all or no energy system(s) that are evaluated as being "cost-effective and viable". With the variability of POU's electric system requirements, the cost-effectiveness and viability of energy storage technology options are likely to be different for each POU.
- 3) At the conclusion of these evaluations, and no later than October 1, 2014, the governing body of each POU is required to adopt a target, if appropriate, for the amount (kW or MW) of energy storage the POU will procure by December 31, 2016. In addition, the governing body is required to adopt an additional target for the amount (kW or MW) of energy storage the POU will procure by December 31, 2021.
- 4) Each governing body must reevaluate its procurement targets and policies at least once every three years.

On February 7, 2014, the Board issued Resolution No. 012168 attached hereto in Appendix 1 directing LADWP to determine economically viable energy storage targets for procurement in

2016 and 2021 and to report back to the Board by October 1, 2014 regarding potential procurement targets, if any.

On September 2, 2014 the Board adopted the attached Resolution No. 015033 (Appendix 2) for ESS procurement to be achieved by the first target date December 31, 2016 and the second target date of December 31, 2021.

C. ES Regulation, Policy, and Legislative Impacts

Energy storage technology plays a vital role in various LADWP and regulatory initiatives (See Table 2). The LADWP energy storage procurement plan will be affected by the following legislative and LADWP initiative:

Table 2: Legislative and LADWP Initiatives

SUBJECT	LEGISLATIVE INITIATIVE	LADWP INITIATIVE
Greenhouse Gas (GHG) Senate Bill 1368	Greenhouse Gas (“GHG”) Emissions Performance Standard	Implementation
Renewables Portfolio Standards (RPS) Assembly Bill (AB) 327	Requires IOUs to procure 33% of energy from renewable resources by 2020. ESS procurement assists with RPS integration	Implementation
GHG AB 32	Requires California to reduce greenhouse gas emissions to 1990 levels by 2020	Implementation
Self-Generation	N/A	Self-Generation Incentive Plan (“SGIP”) Establish SGIP to provide incentives for investing in distributed generation
Demand Response	N/A	Load Impacts of Demand Response and Demand Response. ESS may assist in achieving LADWP Demand Response Program

2. Scope & Objectives

In accordance with AB2514, LADWP evaluated existing and future energy storage targets for the entire power system, including transmission, distribution, and customer-level points of interconnection (See Table 3). The analysis determined the viability of additional ESS and its cost effectiveness. LADWP established an ESS development strategy (Table 1) and an ESS Development Schedule (Figure 2).

A. Energy Storage System Development Strategy

Table 3: Energy Storage System Development Strategy

STRATEGY	TASK
LADWP Efforts	<ul style="list-style-type: none"> ➤ Discussion with Subject Matter Experts ➤ Research relevant topics ➤ Participate with Industry working groups ➤ Working with Consultants, EPRI and B&V <ul style="list-style-type: none"> ○ Selected Location Energy Storage Evaluation <ul style="list-style-type: none"> • Generation Level • Transmission Level • Distribution Level • Behind-the-Meter Level ○ Whole Power System Energy Storage Evaluation <ul style="list-style-type: none"> • Maximum Renewable Energy Penetration • Maximum Distributed Renewable Energy Penetration • Maximum Generation Renewable Energy Penetration ○ Cost Benefit Assessments and Feasibility Studies
Collaborative Efforts with SCPPA* ESS Working Group	<ul style="list-style-type: none"> ➤ Interpret AB2514 terms and conditions ➤ Develop cost benefit evaluation models ➤ Evaluate joint efforts in ESS procurement ➤ Issue RFI* or RFP* for ESS

*Southern California Public Power Authority, *RFI: Request for information, *RFP: Request for Proposal

B. Energy Storage System Target Development Schedule

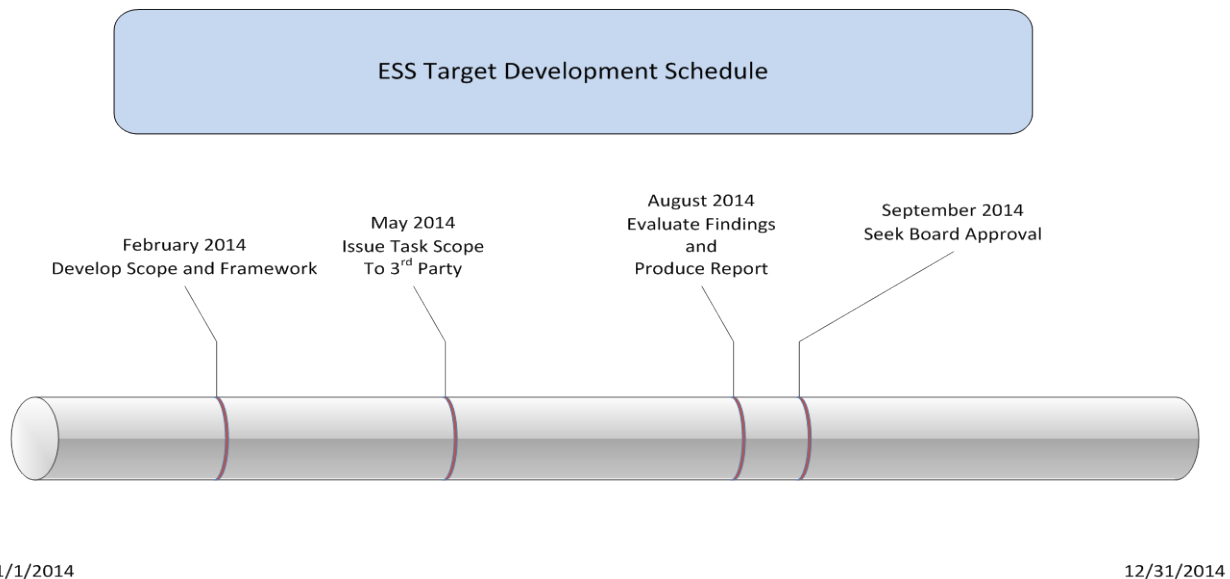

Figure 2: ESS Target Development Schedule

3. Description of Existing and Eligible Energy Storage System

LADWP has over the years built an electric generation, transmission, and distribution system for the sole purpose of serving its native load as a Load Serving Entity (LSE). In addition, LADWP has a responsibility as a Balancing Authority (BA) to maintain and operate transmission and generating assets to (i) continuously balance its BA net scheduled interchange with its actual schedule interchange by dispatching generation units used for regulation, (ii) help the entire interconnection regulate and stabilize the alternating current frequency, and (iii) meet all applicable reliability standards defined by the North American Electric Reliability Corporation (NERC) to maintain reliable operation of the LADWP's bulk electric system. An important characteristic of electricity is that electrical energy cannot be stored directly. At any given moment, there must be almost exactly the same amount of electricity being produced as there is being consumed. If the balance tilts either way, even by a fraction of a percent, it could lead to a blackout. Thus, to sustain the reliability of the bulk power system, LADWP has to constantly monitor, with controllers its bulk power system by predicting demand and making small adjustments, minute-by-minute, to generation output. LADWP performs this function 24 hours a day, 7 days a week. However, the constant balancing of supply and demand has significant operational and cost implications which arise from the need for sufficient generating capacity to supply the highest demand, whether the last incremental capacity will be needed infrequently and/or for short periods of time. Furthermore, the inability to store electricity implies that reserve generating capacity, either in the form of spinning or non-spinning reserves need to be maintained at all times to account for load variability and system disturbance such as an unplanned loss of generation.

While it is not possible to store energy in the form of electricity, historically, LADWP has significantly invested in ESSs that can convert electric energy to another form that can be stored. The stored energy can later be converted back to electricity when it is needed to assist LADWP in performing its LSE and BA responsibilities. This section provides, in the first part, a brief description on LADWP's existing ESS, and in the second part, all eligible ESSs that will be used toward its ESS procurement targets.

A. Existing Energy Storage Systems

1. Large Pump Hydroelectric Plant (Castaic)

Castaic power plant is a seven unit Pump Storage Hydroelectric (PSH) plant owned and operated by LADWP located near the Castaic Lake, California approximately 22 miles north of the Los Angeles upper city limits. Castaic Power Plant is the largest LADWP's hydroelectric resource and the most mature form of energy storage. It provides peak load from potential energy stored in the falling water on the west bank of the California State Aqueduct. The power plant is a cooperative venture between LADWP and the Department of Water Resources of the State of California. An agreement between the two organizations was signed on September 2, 1966 for construction of the project. Castaic Power Plant has six reversible units (1 through 6) rated at 250-MW each before recent upgrades and one conventional unit (Unit 7) rated at 56 MW. Units 1 through 6

function as pumps as well as generators, whereas Unit 7 is an auxiliary unit. Prior to recent upgrades, Castaic Power Plant was rated at 1,247 MW however, the plant name plate installed capacity is higher (1,500 MW). This large capacity reflects the nature of Castaic Power Plant as an energy management system. Table 4 below provides additional information on recent upgrades to Castaic Power Plant.

Table 4: Castaic Power Plant Recent Upgrades

	Unit No.	Date First Carried System Load	Rating (MW)	Recent Upgrades	New Rating (MW)	Net Increase (MW)
Castaic Power Plant	1	7/11/1973	250	11/21/2013	271	21
	2	7/9/1974	250	9/8/2004	271	21
	3	7/13/1976	250	7/10/2009	271	21
	4	6/16/1977	250	6/10/2006	271	21
	5	12/16/1977	250	7/12/2007	271	21
	6	8/11/1978	250	12/25/2005	271	21
					Total =	126

Castaic Power Plant has been and will continue to be an important asset to LADWP. As an LSE, LADWP utilizes Castaic Power Plant to store hundreds of megawatts, which makes it an ideal technology for load leveling and peak shaving. Castaic Power Plant provides valuable ancillary services to LADWP as a BA to ensure the reliability of power system and especially during LADWP’s most challenging hours (hot summers), including (i) the ability to help balance load with generation, (ii) the ability to integrate intermittent energy resources, and (iii) the ability to provide crucial ancillary services to the grid namely, reactive power support, regulation and frequency support service, operating reserve services (both spinning and supplemental).

Because Castaic Power Plant is such a large plant with enormous dependable generating capacity, representing nearly 1.3-GW, it plays a crucial role in meeting LADWP resource adequacy, improving system-wide reliability, and integrating renewable energy resources now and in the future, its presence in LADWP’s generating mix will significantly impact LADWP future ESS procurement targets.

2. Thermal Energy Storage (TES) System

TES system is a concept that involves the use of conventional air conditioning equipment and a storage tank to shift the majority of electricity used for space cooling in LADWP customer facilities from peak to off-peak periods. TES systems produce ice or chilled water during off-peak periods that is stored in a tank and then circulated during the peak periods to produce the desired cooling. TES system installations can be an effective alternative to supply side strategies (adding generation capacity) and/or demand response programs needed to reliably meet the LADWP's peak electrical load growth . TES incentive program is consistent with LADWP's Board-approved efficiency programs that promote the efficient use of electrical energy.

The LADWP has promoted TES technology to its customers since the early 1990s and has paid incentives for the successful installations of TES systems during the last ten years. Two specific

examples include the University of Southern California (USC) and the University of California at Los Angeles (UCLA), together representing 9 megawatts of peak demand reduction. The result was an improvement to LADWP's load factor, shifting customer load from the peak to the base period. In addition, this technology reduced peak in-basin generation, thereby reducing emissions of Nitrous Oxide (NOx). Table 5 below provides a list and size of existing thermal ice storage systems in LADWP's service territory.

Table 5: Completed TES Pilot Projects

Facility Name	System Requirements	Project In-Service Date	Peak Reduction Capacity
McDonalds	(2) 10 Ton RTU	7/7/2008	30 kW
	(2) 12.5 Ton RTU		
Taix Restaurant	(1) 3.5 Ton RTU	12/1/2005	4 kW
	(1) 4.5 Ton RTU		
LADWP Boyle Heights Facility	(1) 10 Ton RTU	10/27/2005	6 kW
University of Southern California (USC)	(1) TES Tank	1/30/2006	4,375 kW
	(4) Pumps		
University of California, Los Angeles (UCLA)	(1) TES Tank	6/15/2004	4,668 kW
	(6) Pumps		
		Total =	9,083 kW

B. Eligible Energy Storage Systems

1. Energy Storage Systems Eligibility Criteria

AB 2514 establishes a statutory definition of “energy storage system,” which will mean “commercially available technology that is capable of absorbing energy, storing it for a period of time, and thereafter dispatching the energy.” The system must use “mechanical, chemical or thermal processes to store energy” or store thermal energy for direct use for heating and cooling at a later time. The system may be centralized or distributed, and may be owned by a load-serving entity, a customer, or a third party. To be an eligible ESS, the system has to be installed and first becomes operational after January 1, 2010. Pumped hydroelectric systems, may not be greater than 50 MW. In addition, ESS shall do one or more of the following:

- (A) Use mechanical, chemical, or thermal processes to store energy that was generated at one time for use at a later time.
- (B) Store thermal energy for direct use for heating or cooling at a later time in a manner that avoids the need to use electricity at that later time.
- (C) Use mechanical, chemical, or thermal processes to store energy generated from renewable resources for use at a later time.
- (D) Use mechanical, chemical, or thermal processes to store energy generated from mechanical processes that would otherwise be wasted for delivery at a later time.

Based on the above eligibility criteria, LADWP has identified the following ESS that will be used toward 2016 procurement target deadline.

2. Castaic Hydroelectric Power Plant Unit 1

Although Castaic Hydroelectric Power Plant is larger than 50 MW, it has undergone major mechanical upgrades which have resulted in incremental capacity that can be used to integrate renewable energy resources, provide additional generation flexibility, and improve system reliability. For that reason, LADWP will only claim incremental Castaic Power Plant upgrades in excess of the existing capacity provided that such excess (i) does not exceed 50 MW capacity limit on pumped storage, and (ii) first became operational after January 1, 2010. Table 6 below provides summary of Castaic Hydroelectric Power Plant Unit 1 capacity gain and performance improvements.

Table 6: Castaic Hydroelectric Power Plant Unit 1 Upgrade

Owner/Operator	LADWP
Utility	LADWP
System/Vendor/Installer	New Generating and Control System/VOITH
Location	CASTAIC
Capacity Before Upgrade	250 MW
Capacity After Upgrade	271 MW
Net Capacity Gain	21 MW
Operational Status	In operation since 11/21/ 2013
Primary Benefit	Improved Efficiency in Generation Mode by 1%
Secondary Benefit	Improved Efficiency in Pump Mode by 2.5%
Total Project Cost	\$41,000,000

3. Approved Thermal Energy Storage Project

The LADWP's commitment to achieving aggressive energy efficiency goals emphasizes a compelling need to promote innovative programs that save both energy and reduce demand. The proposed TES incentive amount is \$750 per kilowatt of demand shifted, a level that will encourage customers to install TES systems while comparing favorably to both the cost of adding generation capacity and to implementing demand response programs. Additionally, a TES system, unlike added generation capacity, is owned, operated, and maintained by the customer. Based on marginal cost studies, the average benefit-to-cost savings ratio (value achieved for every dollar spent) for the proposed program incentive is approximately 3:1. Examples of customers under TES incentive program used as a Permanent Load Shifting (PLS) are listed in Tables 5 and 11 under existing TES system. In line with this, LADWP has approved a onetime incentive plan for the Los Angeles International Airport (LAX), a large customer in LADWP's service territory, to use thermal energy ice storage system to achieve PLS. The approved project requires that a TES be installed to reduce electrical demand. Table 7 below provides a summary of LAX's approved TES age.

Table 7: Approved LAX TES Project Summary

Owner/Operator	LAX
Utility	LADWP
System	TES
Location	LAX
Shifted Capacity	3,025 kW
Operational Status	No later than 2016
Primary Benefit	Annual energy saving of 2,477,681 kWh
Secondary Benefit	Minimize LADWP Peak demand
Incentive Level Cost	\$750/kW shifted or 50% of TES Installed Cost = \$2,022,000

LADWP is conducting a series of studies to investigate ESS applications in LADWP's service territory. In one of these studies, LADWP will study the impact of deploying behind-the-meter TES on LADWP resource adequacy and system reliability while taking into consideration the Renewable Portfolio Standards (RPS) goal which requires electric utility to provide 33% of electric energy sales from renewable by 2020. Findings from this study will provide among other things (i) a measure of the avoided cost of acquiring a new gas-fired power plant as a result of generation capacity displaced by TES, (ii) a cost benefit of deploying behind-the-meter TES in LADWP's service territory, and (iii) the means to design a standardized PLS program based on a standard offer (similar to the LAX project above) with common design rules. The task scope said study hereto in Appendix 8. The purpose of the PLS incentive program is to help offset the cost of initial implementation of PLS technologies. Table 8 below provides a summary of all eligible energy storage systems that will be used towards LADWP's 2016 ESS procurement target.

4. Pilot Energy Storage Systems

LADWP is currently conducting two pilot projects in the LADWP's service territory on BESS. The first project is a 25 kW BESS called "Garage of the Future" located at UCLA. The second project called "La Kretz Innovation Campus Project (LA Downtown)" is a 50 kW to 200 kW BESS project located at the 525 S. Hewitt Street construction site. The purpose of these projects is to investigate how well BESS can be applied to the micro grid system to integrate distributed renewable energy resources for the purpose of promoting energy savings for LADWP's customers and increasing energy efficiency.

Table 8: ESS 2016 Target Summary

Connection Level	System Type	Capacity
Transmission	Pump Hydroelectric Storage	21 MW
Distribution	None	0
Customer	Thermal Energy Storage Sytem	3 MW
	Battery Energy Storage System	75 Kw
	Total =	24.08 MW

4. Energy Storage System Evaluation Methodology

To determine whether ESS is cost-effective and viable, LADWP first evaluated the existing and eligible ESS that could be counted toward LADWP ESS procurement targets and then selected two approaches to determine whether additional ESS procurement targets are technologically viable and cost-effective.

1. Selected Location Energy Storage Evaluation – Identifies specific locations within the Power System where ESS may be the most useful and will be used to set ESS procurement targets. To accomplish this approach, LADWP contracted with Black & Veatch, Electric Power Research Institute (EPRI), and consulted with Southern California Public Power Authority (SCPPA) subject matter experts.
2. Whole Power System Energy Storage Evaluation – Will be used to refine the ESS procurement target for 2021, investigates whether ESS can be integrated at all levels within the Power System namely, generation, transmission, distribution, and behind-the-meter for the purposes of (i) integrating renewable energy, (ii) reducing peak load demand, (iii) deferring power system upgrade, and (iv) improving the overall system reliability. To accomplish this approach, LADWP is in the process of issuing two study task scopes to third parties:

Task Scope 1: Maximum Distribution Renewable Energy Resource Penetration Study

This study evaluates the impact of the maximum distributed photovoltaic (PV) solar into the LADWP distribution system from now through 2020. The study will address whether ESS could be used cost-effectively to eliminate or minimize technical concerns resulting from integrating higher penetration of PV System including, but are not limited to grid stability, voltage regulation, power quality (voltage rise, sag, flicker, harmonics, and frequency fluctuation), reverse power flow, and system protection and coordination.

Task Scope 2: Maximum Generation Renewable Energy Resource Penetration Study

This study will analyze the impact of high penetration of large scale variable energy resources and distributed solar PV generation on LADWP system balancing requirements including reserve requirements, ramp rate requirements, system reliability and operation requirements (system inertia and frequency response), and generation dispatch strategies. The study will assess whether ESS is an economical and viable alternative to acquiring a simple cycle natural gas-fired unit in the event that additional generation capacity is needed to integrate renewable energy resources or improve overall system reliability.

Any viable and cost-effective ESS solutions recommended for procurement from studies described above, whether from the first approach or the second, will proceed to a feasibility study. The purpose of feasibility is to evaluate whether proposed ESS projects from studies recommendations are technically and environmentally feasible (electrical, spatial, environmental constraints and impact assessments, and incentive program survey) and feasible within the estimated cost. It may take two or more years to complete the feasibility studies before ESS can be procured. For that reason, a project that is deemed viable and cost-effective, but

recommended for a feasibility study will be included in the 2021 ESS procurement target. Otherwise, a project will be part of the 2016 targets based on its completed feasibility study.

The process described above and illustrated in Figure 3 below forms the analytical framework from which LADWP will determine its ESS targets for procurement in 2016 and 2021 with a reevaluation process occurring once every three years aimed at refining proposed ESS targets described herein.

Energy Storage System Target Development Process

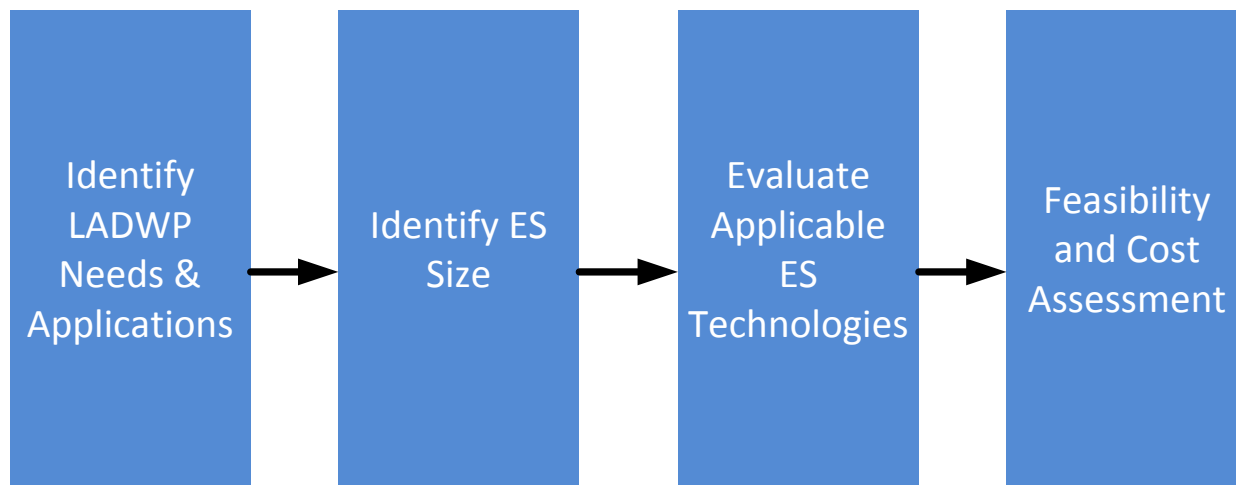

Figure 3: ESS Target Development Process

Each ESS technology will be selected based on connection level and type of the application. See Appendix 3 for Energy Storage Application Matrix.

A. Selected Location Energy Storage Evaluation

In the Selected Location Energy Storage Evaluation LADWP reviews and assesses potential issues in its system attributed to higher PV Solar penetration. These issues include, but are not limited to regulation service for transmission connected energy storage, reverse power flow, overvoltage, and over-generation for distribution connected energy storage. In addition, this approach evaluates whether ESS could mitigate those issues and determines the proper ESS size. Cost benefit analysis are then performed for those selected ESS. Selected ESS solutions are evaluated and analyzed in four different levels:

- Generation Level
- Transmission Level
- Distribution Level
- Behind-the-Meter Level

1. Generation Thermal Energy Storage Solutions

During the summer peak demand, Combustion Turbines and Combined Cycle plants operate at lower capacity due to higher temperature of inlet air. Generation TES would chill stored water during off-peak night hours when the cost of energy is cheaper. The chilled water would be stored

in a TES tank. During on-peak hours Combustion Turbine and Combined Cycle plants would produce more electricity by reducing inlet temperature using stored chilled water. The flow of the water can be adjusted to provide regulation up/ down. Valley Generating units 5, 6, and 7 have been identified as potential candidates to be retrofitted with Generation TES to offer the following:

- Capacity contribution
- Capital deferment for new fossil fuel-power peaking generation
- Peak shaving
- Peak shifting
- Ancillary services
- Reduced cycling cost at thermal generation plants
- Renewable energy integration support

Findings and Recommendation

LADWP preliminary assessment indicates that 60 MW of Generation TES could be achieved at Valley Generating Units 5, 6, and 7 based on existing turbine models and an estimate of all lost power that may be recovered. This capacity can be added to the LADWP’s 2021 ESS procurement targets. Table 9 below provides a comparison between Generation TES and small simple cycle installed cost.

Table 9: Generation TES Installed Cost vs. Small Simple Cycle Installed Cost

Technology Type	Installed Cost (\$/kW)	Capacity (MW)
Small Simple Cycle	1385	50
Generation Thermal Energy Storage	400	60

2. Transmission Connected Energy Storage

Energy storage for Renewable Energy Integration

LADWP is in the process of adding more Solar Generation to meet RPS goals. Adding more renewable could mean adding volatility into the LADWP grid system. This methodology studied ESS implementation to aid renewable energy integration at or near the following locations due to their relative significance to the LADWP RPS goals.

The Cluster of three Solar Plants

- Beacon Solar Project is anticipated to be in service at the end of 2016. Total capacity from Beacon site is 600 MW. Adjacent to Beacon solar plant, is a 9 MW solar plant (Pine Tree Solar) and 120 MW wind plant (Pine Tree Wind). The three plants are included in the study.
- Q09 Solar Project is anticipated to be in service in 2020 with a name plate capacity of 200 MW.
- Copper Mountain with a 250 MW name plate capacity will be gradually added to the grid.

The overall approach includes assessing whether ESS is economically viable at any of the three locations based on prioritized services that ESS could provide. Those ESS services include, but are not limited to:

- Ramp rate control
- Frequency regulation
- Capacity firm of the solar PV plant
- Capacity contribution

Energy Storage for Capital Deferment

The LADWP 2013 Long-Term Transmission Assessment identifies contingencies which require planned and controlled load shedding in order to comply with the North American Electric Reliability Corporation (NERC) Reliability Standard Category C (TPL-003-0a). The assessment indicates possible load shedding at the Olympic Receiving Station (RS-K) under two transmission line outages (N-2) contingencies. LADWP studied all possible cost-effective ESS implementations that might be utilized at that station to reduce load shedding.

Findings and Recommendation

LADWP contracted with Black & Veatch (B&V) to evaluate ESS at the transmission level. In that study B&V used its own proprietary energy storage technical model, SmartES, for sizing ESS. Electric Power Research Institute (EPRI)'s dispatch model Energy Storage Valuation Tool (ESVT) was used to perform cost benefit analysis. GE's PSLF was used to simulate frequency and voltage impacts due to extreme PV ramping scenarios and to ensure system reliability.

The Energy Storage Cost Effectiveness & Viability Report by B&V found that energy storage size of 30 MW at Beacon Solar, and 20 MW at Q09 Solar Plants are technically viable and cost effective (Figures 4 and 5). Based on these findings, LADWP will procure ESS at these two locations by 2021 contingent upon completing feasibility studies. ESS at Copper Mountain is not feasible due to nature of Power Purchase Agreement.

The B&V Report also found that ESS at RS-K (Olympic Receiving Station) for capital deferment and capital contribution are not cost-effective to be procured and installed due to the high cost of ESS when compared to cost of the needed transformer upgrade at the station which is an alternative option to ESS (See Appendix 4 Energy Storage Cost Effectiveness & Viability Report by B&V).

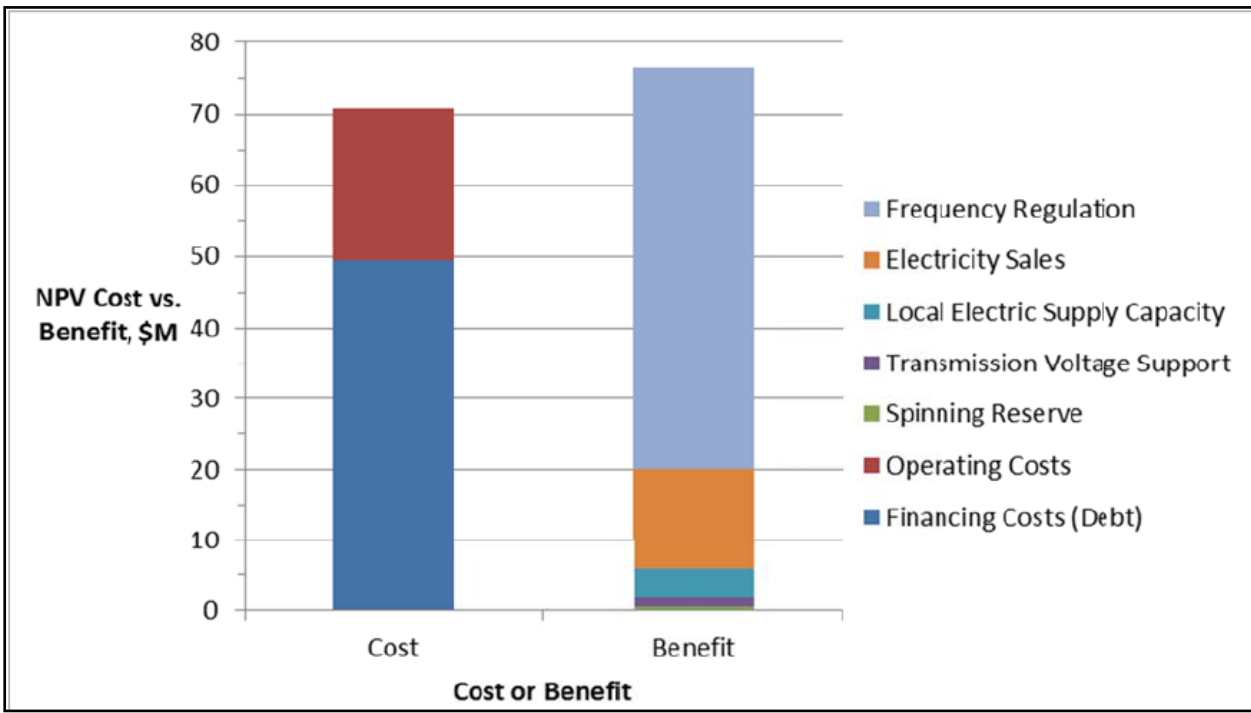

Figure 4: B&V Costs and Benefits for Beacon Solar Plant ESS

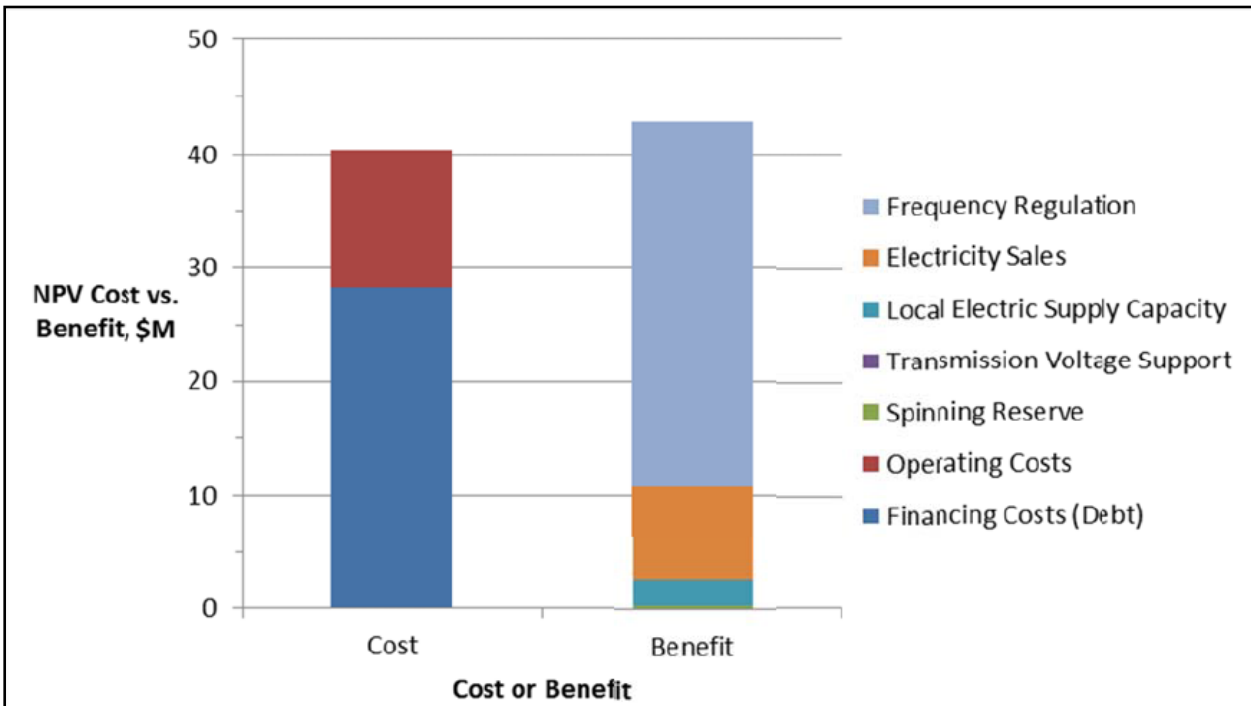

Figure 5: B&V Costs and Benefits for Q09 Solar Plant ESS

3. Distribution Connected Energy Storage

The study by EPRI investigated the potential grid impacts of adding ESS to the distribution system. It entailed developing accurate storage models that could be used to study the effect of storage within distribution systems. It included conducting technical analysis using simulations and models of real distribution feeders as well as studying the operational requirements of energy

storage to provide different grid services. Potential services that could be provided by ESS include, but are not limited to:

- Localized voltage regulation
- Deferred investments in the distribution system
- Shifting distributed solar energy high production to peak load period

Energy Storage for Distributed PV Solar Integration

The study focused on a selected 34.5kV circuit with potentially higher PV solar installation. It detailed electrical models of the selected circuit with anticipated distributed PV system output data in order to evaluate, at the substation level, the aggregated impact of PV integration. The study modeled and identified potential problems associated with high PV solar penetration. The potential locations and approximate sizes of ESS are identified to provide:

- Peak Shaving
- Load Shifting
- PV Smoothing with Volt – VAR control

Energy Storage for Demand Response Program

The study also evaluated the ESS as a Demand Response program (DR) tool to mitigate effects of over-generation from renewables. First, potential customers that may benefit from said DR are identified. Then, the size of ESS is determined for both the benefit of DR and possible over-generation mitigation at the distribution level.

Findings and Recommendation

LADWP has joined EPRI's research program to evaluate ESS at the distribution level. EPRI uses OpenDSS to perform Distribution System impact analyses. The analyses provide appropriate energy storage sizes for a selected 34.5 circuit to determine the size of ESS for solar PV penetration and DR program. Then EPRI's Energy Storage Valuation Tool (ESVT) is used to perform cost benefit analysis of the selected ESS. Several scenarios are created for sizing ESS and cost benefit analysis. The System-Level Stacked Up Benefits case considers the distribution asset deferral, capacity upgrade deferral, energy time-shift, regulation services, and voltage support & reverse power flow. The outcomes of all scenarios show that the use of ESS for a selected circuit is not cost-effective during 2014 to 2020 and beyond (See Appendix 5 for Energy Storage Distribution Impact and Value Analysis by EPRI). At this present time the selected circuit has high thermal capacity and LADWP anticipates other circuits might be in need of ESS at the conclusion of the study performed under the second approach described below. For this reason LADWP recommends ESS size of 4 MW as part of its 2021 targets.

4. Customer Connected Energy Storage Solutions

Thermal Energy Storage (TES)

The efficiency of the power system is decreased when ambient temperature and load demands are high. Moreover, it is estimated that 30% of the load is due to cooling needs during high peaks. Behind-the-meter TES can be used to make ice during off-peak night hours, then melt the ice to cool buildings. Behind-the-meter TES will provide the following benefits to the system:

- Peak shaving
- Load shifting
- Defer investments in the distribution system
- Over-generation mitigation due to renewable energy high penetration
- Reduced cycling cost at thermal generation plants

Findings and Recommendation

LADWP used SCPPA's Resource Screening Tools to evaluate cost effectiveness based on existing TES incentive amount of \$750 per kW of demand shifted and 20 years of equipment life span (see Table 10 below for the result of customer level thermal storage cost benefit analysis).

Table 10: Customer Level Thermal Storage Cost Benefit Analysis.

Resource	Installed Cost (\$/kW)	Levelized Cost (\$/kW-year)	Energy Cost (\$/MWH)	Simple Payback (yrs)
Energy Efficiency Program			\$17	never
Demand Response Program		\$237		< 1 year
Small Simple Cycle (49.9 MW)	\$1,385	\$220	\$362	< 1 year
Large Simple Cycle (100 MW)	\$1,339	\$216	\$362	< 1 year
Advanced Simple Cycle (200 MW)	\$1,104	\$236	\$251	< 1 year
Combined Cycle-Duct Fired (550 MW)	\$1,081	\$655	\$135	< 1 year
Biomass Fluidized Bed (50 MW)	\$4,978	\$1,051	\$161	< 1 year
Geothermal Binary (30 MW)	\$6,346	\$739	\$126	< 1 year
Geothermal Flash (30 MW)	\$7,006	\$848	\$154	< 1 year
Solar Parabolic Trough (250 MW)	\$4,293	\$397	\$209	< 1 year
Solar PV Thin Film (100 MW)	\$3,099	\$258	\$192	< 1 year
Wind - Class 4 (100 MW)	\$1,912	\$297	\$117	< 1 year
ISO Market (Peak Capacity \$/kW-mo)	n/a	n/a	n/a	n/a
Lithium-Ion	\$1,950	\$210	\$170	< 1 year
TES / PLS (including financing costs)	\$2,076	\$104	\$180	

* source: (1) Generation Resource Cost data is taken from the California Energy Commission *Cost of Generation (COG)* Model, dated May 2013
COG Model outputs reflect the cost of generation for POU construction, under the "Mid-range" pricing assumptions

(2) Solar and wind energy prices are taken from CEC COG model and do not reflect recent price offerings tht SCPPA has experienced.

(3) EE Program data are Utility-specific, based on FY2013 SB1037 Report and assumptions contained herein.

These results show that the Department's levelized cost of the peak load shift capacity is less than all other resources that have been used for comparative purposes. As shown in the last column of

Table 10, this low cost of peak load shift capacity provides a simple payback of less than 1 year for the TES when compared to the cost of developing all other resources of a similar size, except energy efficiency programs.

40 MW of TES at customer level is found to be viable. A full feasibility study including customer survey to gain insight on the level of customer interest in the TES incentive program will be required to meet this target. Creating incentives for customers that combines effort with Energy Efficiency and Demand Response programs will add greater value to behind-the-meter TES. Customers may earn additional saving by being on the Time-of-Use program. Behind-the-meter TES is fully dispatchable and utilities can use this form of ESS to mitigate over-generation in presence of high penetration of variable energy resources (See Figure 6).

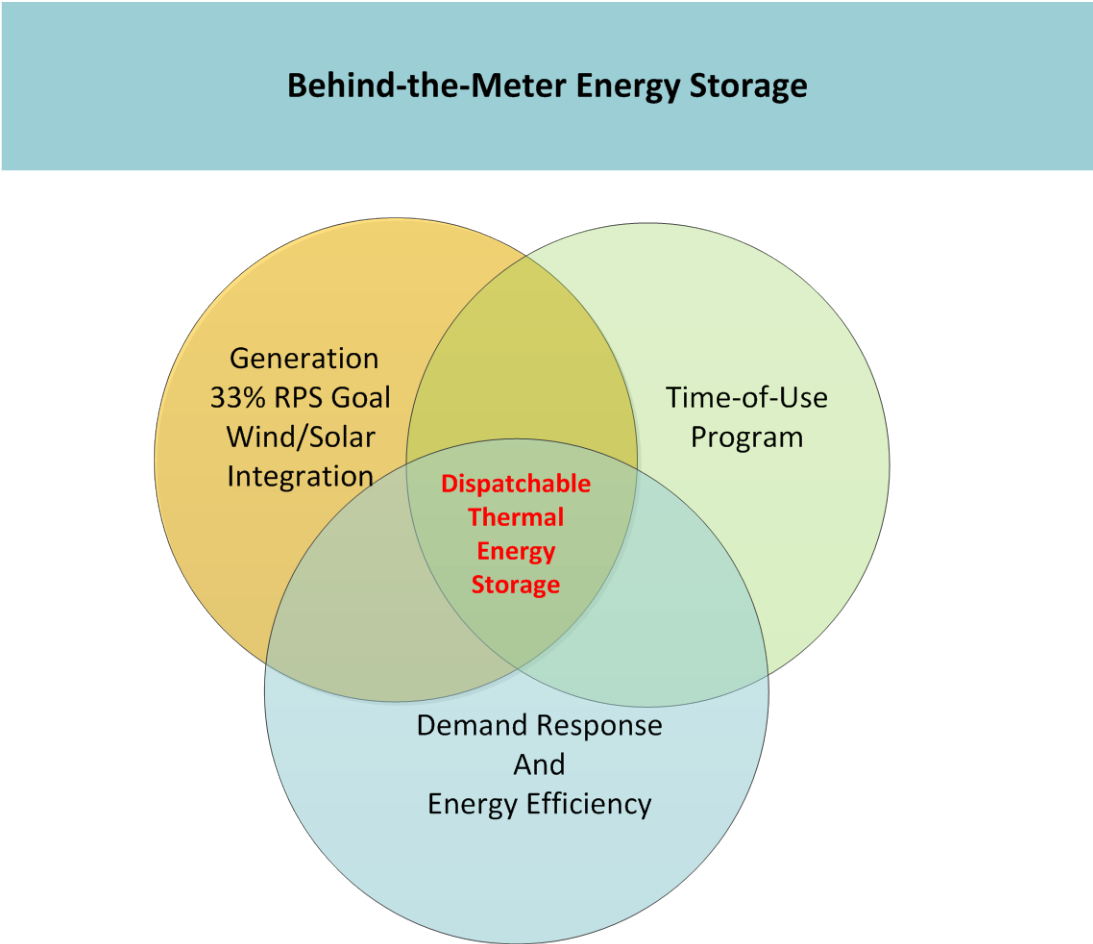

Figure 6: Multiple Usage of Behind-the-Meter-Energy Storage

B. Whole Power System Energy Storage Evaluation

LADWP is in the process of increasing renewable energy resources in order to comply with State mandates. As the amount of renewable energy continues to increase there is a need to identify the maximum location-specific production of renewable energy on the LADWP grid system. Maximum Renewable Energy Penetration Study (MREPS) and Maximum Distribution Renewable Energy Penetration Study (MDREPS) identified those locations in the LADWP power system at the transmission and distribution level, respectively. The Maximum Generation Renewable Energy

Penetration Study (MGREPS) will evaluate how existing thermal generation would be utilized to integrate anticipated variable renewable generation.

Maximum Renewable Energy Penetration Study (MREPS)

The goal of the MREPS was to (1) determine the maximum renewable penetration on its transmission system, (2) identify transmission or system constraints that limit renewable production, and (3) recommend the most efficient strategies for operating these renewable resources. The study identified the weak link in the power system with high renewable penetration. The study recommended deployment of ESS at the potential solar plant.

Maximum Distribution Renewable Energy Penetration Study (MDREPS)

MDREPS will quantify the maximum possible distributed PV solar penetration below which locally generated electric energy can be integrated safely and reliably with no adverse impact to distribution facilities and above which significant improvements and/or distribution network upgrades are required for incremental DG output. The voltage levels of integration point are 4.8 kV and 34.5kV.

MDREPS will identify the existing and potential impact of maximum possible PV solar integration on LADWP's distribution system operations, including but not limited to voltage and stability, power quality, power factor, harmonics, transients, distribution system protection, distributed PV solar relaying, and the possible risk of back feed power.

MDREPS will provide safe and reliable mitigation solutions to all identified adverse impacts as a result of deploying a considerable amount of PV solar into LADWP's distribution system. ESS solutions are considered a possible solution at the distribution level and behind-the-meter.

Maximum Generation Renewable Energy Penetration Study (MGREPS)

The study will analyze the impact of high penetration of variable energy resources and distributed PV solar generation on the LADWP system balancing requirements such as

- Reserve requirements
- Ramp rate requirements
- System reliability
- Operation requirements (system inertia and frequency response)
- Generation dispatch strategies

It will also provide mitigation measures including ESS on generation balancing requirements.

Finding and Recommendation

LADWP contracted with Leidos to perform the MREPS. Based on the MREPS report, Leidos recommended investing in ESS with frequency droop and short term overload capability for new renewable projects (See Appendix 6 for MREPS Report).

MGREPS and MDREPS will be rather extensive and will look at interactions of the LADWP's power system with maximum renewable generation. LADWP owns and operates more than 1500 4.8kV feeders and more than 500 34.5kV circuits. LADWP anticipates completing both studies in 2015. Those additional findings will reflect LADWP energy storage targets and will be updated again by October 2017. See Appendix 7 and 8 for the scope of work for these two studies.

5. ESS Summary of Targets

Table 11: ESS Summary of Targets

CONNECTION LEVEL	Existing TARGETS			PROPOSED TARGETS						
	PRE 2010			2016 TARGETS			2021 TARGETS			
	Project Name	Energy Storage Type	Capacity	Project Name	Energy Storage Type	Capacity	Project Name	Energy Storage Type	Capacity	
GENERATION	Castaic	Pump Storage Hydro	1275 MW	Castaic	Pump Storage Hydro	21 MW	Valley Generating Station	Thermal Energy Storage	60 MW	
	Sub-Total		1275 MW	Sub-Total		21 MW	Sub-Total		60 MW	
TRANSMISSION	None			None			Beacon Solar Project	Battery Energy Storage	30 MW	
							Q09 Solar Project	Battery Energy Storage	20 MW	
							Sub-Total		50 MW	
DISTRIBUTION	None			None			Distribution Circuit	Battery Energy Storage	4MW	
							Sub-Total		4 MW	
CUSTOMER	UCLA	Thermal Energy Storage	4.375 MW	LAX	Thermal Energy Storage	3 MW	Distributed Energy Storage System	Thermal Energy Storage	40 MW	
	USC	Thermal Energy Storage	4.668 MW							
	TAIX	Thermal Energy Storage	.004 MW	LA Downtown (Pilot)	Battery Energy Storage	.05 MW				
	LADWP Boyle Heights Facilities	Thermal Energy Storage	.006 MW	Garage of the Future (Pilot)	Battery Energy Storage	.025 MW				
	McDonald	Thermal Energy Storage	.03 MW							
	Sub-Total		9.08 MW	Sub-Total		3.08 MW				Sub-Total
TOTAL			1284.08 MW	TOTAL			24.08 MW	TOTAL		154 MW

6. Procurement Mechanism

LADWP may procure ESS through three main mechanisms:

- Utility-Owned
- Customer Incentive Programs
- Collaborative Ownership

A. Utility – Owned

LADWP may procure generation, transmission, and distribution connected ESS mostly through its competitive solicitation process. Under this process, LADWP will make a solicitation through a bidding process by issuing a Request for Proposal (RFP) to potential suppliers to submit ESS procurement proposals. The RFP outlines the bidding process and contract terms, and provides guidance on how the bid should be formatted and presented. A RFP is typically open to a wide range of bidders, creating open competition between companies looking for business opportunities. To issue an RFP, LADWP follows the following guidelines including, but are not limited to (i) informing vendors about LADWP procurement needs and encouraging them to participate in the bidding process, (ii) informing vendors about the competitive nature of the selection process, (iii) allowing a wide distribution and responses, (iv) ensuring the vendors are responsive to the bid and ensuring that vendors response is factual to the identified requirements, (v) following LADWP's evaluation and selection procedure to ensure impartiality in the awarding process.

B. Customer Incentive Programs

LADWP may acquire behind-the-meter ESS primarily through its TES incentive program to permanently shift load. As defined by CPUC Resolution E-4586, "Permanent Load Shifting" refers to the shifting of energy usage from one period of time to another on a recurring basis, often by storing energy produced during off-peak hours and using the energy during peak hours to support loads. PLS technology of interest under this incentive program is mostly ice storage. Ice storage systems use a standard chiller to produce ice overnight which is stored in tanks. The stored ice is used to cool buildings the following day. This type of energy storage is especially important since conventional cooling equipment consume significant amount of energy: electricity demand during summer peaks are largely due to the need for cooling. It is anticipated that TES incentive program will provide more flexibility to generation resource management by efficiently using underutilized night time generation and enhance the integration of variable energy resources by absorbing over-generation when loads are low. Energy from ice is fully dispatchable to offset intermittent availability associated with variable energy resources. Under the current incentive program, the customer receives \$750 per kW shifted when the ESS permanently displaces customer demand peak to other times. The incentive is capped at 50% of the total eligible project costs. However, this TES incentive program may need to be restructured to maximize its value to both customers and the utility by combining efforts from Energy Efficiency and Demand Response programs.

C. Collaborative Ownership

LADWP has successfully procured many projects through SCPPA which facilitates joint ownership among members.

SCPPA's Request for Proposal was issued on February 1, 2014 with a response deadline of December 31, 2014. LADWP will be actively looking for collaborative opportunity with SCPPA members for ESS procurement projects. RFP responders may propose:

- project ownership by SCPPA
- a power purchase agreement (or an equivalent commercial agreement with an ownership option), or
- a power purchase agreement (or an equivalent commercial agreement without an ownership option)

As a “rolling RFP” SCPPA reserves the right to contact proposers at any time to start negotiations, and to execute one or more agreements before the proposal deadline (See Appendix 9 for SCPPA Request for Proposals for Renewable Energy and Energy Storage Projects).

7. Rate Recovery

The procurement of ESSs described herein will have a significant impact on LADWP's power system both operationally and financially. On one hand the addition of these ESSs into the grid may improve the overall system reliability especially with the integration of renewable energy resources. On the other hand, may add complexity to the day to day operation of the LADWP bulk power system. ESS procurement requires significant capital investment. Securing these investments in turn may require a rate increase process for LADWP. While the rates and charges of investor-owned utilities (such as PG&E, SCE, and SDG&E) are approved at the state level, those decisions for LADWP are made at the local government level, namely the Los Angeles City Council. To seek the approval of the energy storage procurement targets from LADWP's Board of Commissioners, LADWP has to demonstrate that meeting these procurement targets will (i) be cost-effective, (ii) improve the reliability of the grid, thereby providing significant savings to the Los Angeles City ratepayers, and (iii) not risk saddling ratepayers with cost for unnecessary ESSs for the sake of fostering innovation and a sustainable market in energy storage technology. These guidelines form the basis for LADWP energy storage procurement targets.

Appendix 1

Board Approved Resolution No. 012168 AB2514 Initiation

This space is intentionally left blank

RESOLUTION NO. 012 168

WHEREAS, State Assembly Bill 2514 (AB 2514) became law on January 1, 2011, requiring the governing board of a local publicly owned electric utility, such as the Los Angeles Department of Water and Power (LADWP), to initiate a process by March 1, 2012, to determine appropriate targets, if any, for LADWP to procure viable and cost-effective energy storage systems by certain dates; and

WHEREAS, if determined to be appropriate, the Board of Water and Power Commissioners (Board) shall adopt procurement targets by October 1, 2014, for LADWP to procure viable and cost-effective energy storage systems to be achieved by a first target date of December 31, 2016, and a second target date of December 31, 2021; and

WHEREAS, LADWP's 2011 Power Integrated Resource Plan (IRP) provides a review of the general requirements of grid-scale energy storage systems and technologies and includes a proposed energy storage demonstration project, which may serve as an initial framework to determine appropriate targets, if any, for LADWP to procure viable and cost-effective energy storage systems; and

WHEREAS, pursuant to AB 2514, the Board shall re-evaluate the determinations made regarding energy storage system procurement not less than once every three years; and

WHEREAS, LADWP shall report to the California Energy Commission regarding any energy storage system procurement targets and policies that may be adopted by this Board, and any modifications made to those targets as a result of the Board's reevaluations.

NOW, THEREFORE, BE IT RESOLVED that the Board of Water and Power Commissioners of the City of Los Angeles hereby initiates a process directing LADWP to determine appropriate targets, if any, for LADWP to procure viable and cost-effective energy storage systems by December 31, 2016, and December 31, 2021 pursuant to AB 2514.

BE IT FURTHER RESOLVED that LADWP shall report back to this Board prior to October 1, 2014, regarding potential procurement targets, if any, for LADWP to procure viable and cost-effective energy storage systems, at which time this Board may determine whether it is appropriate to adopt such targets.

I HEREBY CERTIFY that the foregoing is a full, true, and correct copy of a resolution adopted by the Board of Water and Power Commissioners of the City of Los Angeles at its meeting held FEB 07 2012

APPROVED AS TO FORM AND LEGALITY
CARMEN A. TRUTANICH, CITY ATTORNEY

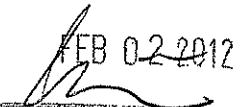
BY  FEB 02 2012
VAUGHN MINASSIAN
DEPUTY CITY ATTORNEY

Secretary

This space is intentionally left blank

Appendix 2

**Board Approved Resolution No. 015033 for Energy Storage
Target Adoption**

This space is intentionally left blank

WHEREAS, California State Assembly Bill 2514 (AB 2514) became law on January 1, 2011, requiring the governing board of a local publicly owned electric utility, such as the Los Angeles Department of Water and Power (LADWP), to initiate a process by March 1, 2012, to determine appropriate targets, if any, for LADWP to procure viable and cost-effective energy storage systems by certain dates; and

WHEREAS, if determined to be appropriate, the Board of Water and Power Commissioners (Board) shall adopt procurement targets by October 1, 2014, for LADWP to procure viable and cost-effective energy storage systems to be achieved by a first target date of December 31, 2016, and a second target date of December 31, 2021; and

WHEREAS, the Board on February 7, 2012, initiated a process directing LADWP to determine appropriate targets, if any, for LADWP to procure viable and cost-effective energy storage systems by December 31, 2016, and December 31, 2021 pursuant to AB 2514; and

WHEREAS, to conform to AB 2514 and consistent with Board Resolution No. 012-168 LADWP has developed an analytical framework from which its energy storage system targets for procurement in 2016 and 2021 will be deduced, which include system and feasibility studies aimed at investigating economically viable energy storage systems at four points of interconnection: generation, transmission, distribution and behind the meter or customer; and

WHEREAS, LADWP declares that, based on the assessment of existing eligible energy storage systems, there are two projects that are deemed eligible energy storage systems namely, a generation connected storage with a net incremental capacity of 21 Megawatt (MW) and an incentivized customer connected storage with a rated peak demand shift of 3 MW, and LADWP will primarily rely on these two projects to fulfill its 2016 procurement targets totaling 24 MW; and

WHEREAS, LADWP states that, based on preliminary assessments and findings from studies performed thus far, there are five projects that are deemed relatively cost-effective namely, generation connected thermal energy storage with an incremental rated capacity approximated at 60 MW, two transmission connected battery energy storages with a combined capacity of 50 MW, one distribution connected battery energy storage rated at 4 MW, and one customer connected storage with a potential rated peak demand shift of 40 MW for a total of 154 MW; and

WHEREAS, pursuant to AB 2514, the Board shall re-evaluate the determinations made regarding energy storage system procurement not less than once every three years; and

WHEREAS, LADWP shall report to the California Energy Commission (CEC) regarding any energy storage system procurement targets and policies that may be adopted by the Board, and any modifications made to those targets as a result of the Board's reevaluations.

NOW, THEREFORE, BE IT RESOLVED that the Board of Water and Power Commissioners of the City of Los Angeles hereby adopts the procurement targets of 24 MWs of energy storage systems for December 31, 2016 and 154 MWs of energy storage systems for December 31, 2021 pursuant to AB 2514.

BE IT FURTHER RESOLVED that LADWP shall report to the CEC regarding these adopted energy storage system procurement targets and report any modifications made to those targets as a result of reevaluation.

BE IT FURTHER RESOLVED that LADWP shall report back to the Board prior to September 2, 2017, for the Board to reevaluate the determinations made regarding the energy storage system procurement targets and shall report to the CEC any modifications made to those targets as a result of the Board's reevaluations.

I HEREBY CERTIFY that the foregoing is a full, true, and correct copy of a resolution adopted by the Board of Water and Power Commissioners of the City of Los Angeles at its meeting held SEP 02 2014

Barbara E. Hoehner

Secretary

APPROVED AS TO FORM AND LEGALITY
MICHAEL N. FEUER, CITY ATTORNEY

AUG 15 2014

BY

Vaughn Minassian
VAUGHN MINASSIAN
DEPUTY CITY ATTORNEY

Appendix 3
Energy Storage Application Matrix

This space is intentionally left blank

ENERGY STORAGE APPLICATION MATRIX			
Technology	Primary Application	What We Currently Know	Challenges
Compressed Air Energy Storage	<ul style="list-style-type: none"> Energy management Backup and seasonal reserves Renewable integration 	<ul style="list-style-type: none"> Better ramp rates than gas turbine plants Established technology in operation since the 1970's 	<ul style="list-style-type: none"> Geographically limited Lower efficiency due to roundtrip conversion Slower response time than flywheels or batteries Environmental impact
Pumped Hydro Energy Storage	<ul style="list-style-type: none"> Energy management Backup and seasonal reserves Regulation service also available through variable speed pumps 	<ul style="list-style-type: none"> Developed and mature technology Very high ramp rate Currently most cost effective form of storage 	<ul style="list-style-type: none"> Geographically limited Plant site Environmental impacts High overall project cost
Flywheel Energy Storage	<ul style="list-style-type: none"> Load leveling Frequency regulation Peak shaving and off peak storage Transient stability 	<ul style="list-style-type: none"> Modular technology Proven growth potential to utility scale Long cycle life High peak power without overheating concerns Rapid response High round trip energy efficiency 	<ul style="list-style-type: none"> Rotor tensile strength limitations Limited energy storage time due to high frictional losses
Advanced Lead-Acid Batteries	<ul style="list-style-type: none"> Load leveling and regulation Grid stabilization 	<ul style="list-style-type: none"> Mature battery technology Low cost High recycled content Good battery life 	<ul style="list-style-type: none"> Limited depth of discharge Low energy density Large footprint Electrode corrosion limits useful life
Sodium-Sulfur (NaS) Batteries	<ul style="list-style-type: none"> Power quality Congestion relief Renewable source integration 	<ul style="list-style-type: none"> High energy density Long discharge cycles Fast response Long life Good scaling potential 	<ul style="list-style-type: none"> Operating temperature required between 250° and 300° C Liquid containment issues (corrosion and brittle glass seals)
Lithium-Ion Batteries	<ul style="list-style-type: none"> Power quality Frequency regulation 	<ul style="list-style-type: none"> High energy density Good cycle life High charge/discharge efficiency 	<ul style="list-style-type: none"> High production cost - scalability Extremely sensitive to over temperature, overcharge and internal pressure buildup Intolerance to deep discharges
Flow Batteries	<ul style="list-style-type: none"> Ramping Peak shaving Time shifting Frequency regulation Power quality 	<ul style="list-style-type: none"> Ability to perform high number of discharge cycles Lower charge/discharge efficiencies Very long life 	<ul style="list-style-type: none"> Developing technology, not mature for commercial scale development Complicated design Lower energy density
Superconducting Magnetic Energy Storage (SMES)	<ul style="list-style-type: none"> Power quality Frequency regulation 	<ul style="list-style-type: none"> Highest round-trip efficiency from discharge 	<ul style="list-style-type: none"> Low energy density Material and manufacturing cost prohibitive
Electrochemical Capacitors	<ul style="list-style-type: none"> Power quality Frequency regulation 	<ul style="list-style-type: none"> Very long life High reversible and fast discharge 	<ul style="list-style-type: none"> Currently cost prohibitive
Thermochemical Energy Storage/ Thermal Energy Storage/ Generation Storage	<ul style="list-style-type: none"> Load leveling and regulation Grid stabilization 	<ul style="list-style-type: none"> Extremely high energy density 	<ul style="list-style-type: none"> Currently cost prohibitive

TRANSMISSION												
Frequency Regulation	Peak Shifting and Firming	Ramping	Renewable Integration	Black Start	Load Shaving	Power Quality	Deferring Transmission Upgrade	Congestion Mitigation	Regulation, Load Following	Transient Stability, Improve Short-Duration Performance	Backup and Seasonal Reserves	Spinning and Non-Spinning Reserves
			●	●			●				●	●
				●			●		●		●	●
●	●				●				●	●		
	●			●	●		●		●			
●	●				●	●	●					
●												
	●								●			

DISTRIBUTION					
Power Quality	Deferring Distribution Infrastructure Upgrade	Peak Shifting Downstream of Distribution System	Intermittent Distributed Generation Integration	Micro-Grid Formation	Transportable Outage Mitigation
●	●	●	●	●	●
●	●	●	●	●	●
●	●	●	●	●	●
		●			

BEHIND THE METER				
Time-of-Use Rate Optimization	Intermittent Distributed Generation Integration	Micro-Grid Formation	Power Quality	Backup Power During Outages
○				
○				
			●	●
●	●	●	●	●
●	●	●	●	●
●	●	●	●	●
●				

Reference: Grid Energy Storage by US Department of Energy Dated December 2013
 SANDIA Report, DOE/ EPRI 2013 Electric Storage Handbook in Collaboration with NRECA, Grid Energy Storage U.S. Department of Energy December 2013

This space is intentionally left blank

Appendix 4

Energy Storage Cost Effectiveness & Viability by Black & Veatch Corporation

This space is intentionally left blank

FINAL

ENERGY STORAGE COST EFFECTIVENESS & VIABILITY

B&V PROJECT NO. 181921
B&V FILE NO. 40.0000

PREPARED FOR



Los Angeles Department of Water and Power

29 AUGUST 2014

**The following members of
Black & Veatch were involved
in this analysis and report:**

Matt Wood

Project Manager

Lucas Oehlerking

Study Manager

Scott Olson

Technical Reviewer

Chad Mazurek

Power Flow Modeler

Charith Tammineedi

Energy Storage Modeler

Sercan Teleke

Energy Storage Consultant

Greg Henry

Grid Integration Consultant

Table of Contents

Executive Summary	1
1.0 Introduction	1-1
1.1 Definitions.....	1-1
1.2 Software Tool Summary.....	1-3
2.0 Battery Energy Storage at Three Solar Projects	2-1
2.1 Analysis Methodology	2-1
2.2 Energy Storage Technology Selection	2-2
2.3 Data Pre-Processing.....	2-3
2.4 Ramp Rate Control Analysis	2-3
2.5 Frequency Regulation Analysis.....	2-9
2.5.1 SmartES Frequency Regulation Analysis	2-9
2.5.2 System Frequency Analysis	2-10
2.6 System Capacity Analysis	2-16
2.7 Economic Analysis.....	2-16
2.7.1 Cycle Life and Degradation	2-16
2.7.2 Capital Costs.....	2-16
2.7.3 Dispatch Optimization via ESVT	2-17
2.7.4 Beacon Solar Analysis	2-21
2.7.5 Copper Mountain Analysis	2-24
2.7.6 Q09 Solar Project Analysis	2-25
2.7.7 High Level Comparison with Alternatives.....	2-27
2.8 Energy Storage Vendors.....	2-27
2.9 Recommendations.....	2-28
3.0 Battery Energy Storage at Olympic Receiving Station	3-1
3.1 Information and Data Reviewed.....	3-1
3.2 Recommendations.....	3-3
Appendix A. SmartES Model References	A-1
Appendix B. ESVT Model References	B-1
Appendix C. PSLF Model References	C-1

LIST OF TABLES

Table 1-1	Key Energy Storage Terms.....	1-1
Table 1-2	Energy Storage Applications	1-2
Table 1-3	Software Tool Capabilities	1-3
Table 2-1	Lithium Ion Battery Performance Table.....	2-3
Table 2-2	Pine Tree Solar Analysis.....	2-4
Table 2-3	Copper Mountain Analysis.....	2-6

Table 2-4	BESS Sizing and Cycles for Ramp Rate Control	2-9
Table 2-5	SmartES Frequency Regulation Cycles	2-10
Table 2-6	Degradation and Capital Cost Summary.....	2-17
Table 2-7	Key Input Assumptions	2-18
Table 2-8	Economic Analysis Results.....	2-20
Table 2-9	Beacon Solar ESVT Results Summary.....	2-21
Table 2-10	Copper Mountain ESVT Results Summary	2-24
Table 2-11	Q09 ESVT Results Summary.....	2-26
Table 2-12	Energy Storage and Combustion Turbine Cost Comparison.....	2-27
Table 2-13	Energy Storage Vendor List.....	2-28

LIST OF FIGURES

Figure 2-1	SmartES Screenshot of Variable Day from Pine Tree Solar Analysis	2-5
Figure 2-2	SmartES Screenshot of BESS Response from Pine Tree Solar.....	2-6
Figure 2-3	SmartES Screenshot of Variable Day from Copper Mountain Solar.....	2-7
Figure 2-4	SmartES Screenshot of BESS Response for Copper Mountain Solar.....	2-8
Figure 2-5	Screenshot of Frequency Regulation Analysis and BESS Output/SOC	2-10
Figure 2-6	Beacon Solar – Increased Capacity	2-11
Figure 2-7	50% Ramp Over 1 Minute – Frequency Plots, Value=Hz.....	2-12
Figure 2-8	50% Ramp Over 1 Minute – Voltage Plots, Value=per-unit	2-13
Figure 2-9	Trip Beacon – Frequency Plots, Value=Hz.....	2-14
Figure 2-10	Trip Beacon – Voltage Plots, Value=per-unit.....	2-15
Figure 2-11	ESVT’s Dispatch Hierarchy.....	2-18
Figure 2-12	Beacon Solar NPV Costs and Benefits.....	2-21
Figure 2-13	Benefit-to-Cost Ratio for Various Scenarios of CPUC Cost-Effectiveness Analysis.....	2-23
Figure 2-14	Copper Mountain NPV Costs and Benefits.....	2-24
Figure 2-15	Q09 NPV Costs and Benefits.....	2-26
Figure 3-1	SmartES Screenshot of Peak Shaving Analysis at Olympic Receiving Station	3-3

Executive Summary

California Assembly Bill 2514 requires municipal utilities to self-declare economically viable energy storage targets for procurement in 2016 and in 2021. These targets along with the appropriate justification are due to the California Energy Commission by October 1, 2014. In support of this requirement, the Los Angeles Department of Water and Power (LADWP) retained Black & Veatch to analyze the costs and benefits of transmission system connected battery energy storage projects. Distribution system and customer connected storage are not included in this analysis. This is not a broad analysis of the entire transmission system, but rather a focused analysis on four LADWP provided locations: Beacon Solar, Copper Mountain Solar, Q09 Solar, and the Olympic Receiving Station. The locations represent in LADWP's opinion the locations where storage is most likely to be necessary due to the need for regulating reserves and to mitigate potential load shedding.

Energy storage is a versatile resource that can perform multiple applications to provide value to LADWP's system. The potential storage system applications considered in this analysis are as follows:

- Frequency Regulation
- Ramp Rate Control (solar PV)
- System Capacity
- Capacity Firming (solar PV)
- Electrical Energy Time-Shift
- Voltage Support
- Spinning Reserve
- Non-Spinning Reserve
- Peak Load Shaving

Key to energy storage viability and cost-effectiveness is the ability to provide multiple benefit streams associated with the applications listed above. The applications considered for each potential project and the associated benefits for those applications are summarized in the following two sections. The final section lists recommendations based on this analysis.

Battery Energy Storage at Three Solar Projects

The three solar facilities examined in this study are each greater than 200 MW in size, thus representing the largest intermittent power sources on the LADWP system. LADWP will be responsible for integrating these variable resources to the electric grid; batteries are one option to provide the necessary integration services. The applications and benefits analyzed for this storage system include all noted above except for Capacity Firming and Peak Load Shaving. Of the battery technologies available, Black & Veatch selected lithium ion batteries as best suited for the

applications considered. Lithium ion batteries are a versatile resource common in the industry with good cycle life, fast response time, and high round-trip efficiency.

Black & Veatch used SmartES, a proprietary energy storage performance model, to size an energy storage system for each of the solar PV facilities. Data from operating LADWP solar facilities was used to estimate the level of ramp rate control needed at each location to develop an appropriate battery size. Next, power systems analysis software (PSLF) was used to investigate the system transient stability impacts of two of the three solar plants. This analysis helped to determine if significant ramping or instantaneous tripping of a large solar facility has a significant grid stability impact that can be economically mitigated by battery storage. Finally, economic analysis was done using the Energy Storage Valuation Tool (ESVT) from the Electric Power Research Institute. The economic and financial inputs to this model were decided upon between LADWP and Black & Veatch in a data request process.

Assumptions used for battery cost and performance are shown in the below table. The installed costs of the lithium ion battery storage system used in this report is based largely on Black & Veatch’s Engineering, Procurement and Construction (EPC) experience and available literature.

Battery Cost and Performance Summary

PARAMETER	VALUE
Installed Capital Cost, \$/ kW	1,100
Installed Capital Cost, \$/ kWh	2,200
Interconnection cost, \$/kW	500
Fixed O&M, \$/ kW-yr	10
Variable O&M, \$/kWh	0.002
Replacement Costs, \$/kWh	600
Degradation, %	2.3 – 2.5
Estimated cycles per year	17,500 to 19,000 at 10 % DoD
Expected year of replacement	7 to 8 years
Project life	15 years

The solar projects and the resulting cost effectiveness estimates are summarized in the table below.

Battery Cost Effectiveness Summary

	BEACON SOLAR	COPPER MOUNTAIN	Q09
Solar Capacity, MWac	350	250	200
BESS Power, MW	35	25	20
BESS Energy, MWh	17.5	12.5	10
Cycles/yr at <10% DOD	17,500-19,000	17,500-19,000	17,500-19,000
Cost, \$	70,761,356	50,478,256	40,410,297
Benefit, \$	76,634,779	54,509,180	42,966,260
Benefit-to-Cost Ratio	1.083	1.080	1.063
Internal Rate of Return (IRR), %	8.5	8.1	6.0

This analysis shows that the net benefit to LADWP for storage at any of these sites is positive yet small. The majority of the benefits to the grid come from frequency regulation, as is shown in the ESVT cost/benefit summary for Beacon Solar shown below. The distribution of the costs and benefits are similar for the other locations.

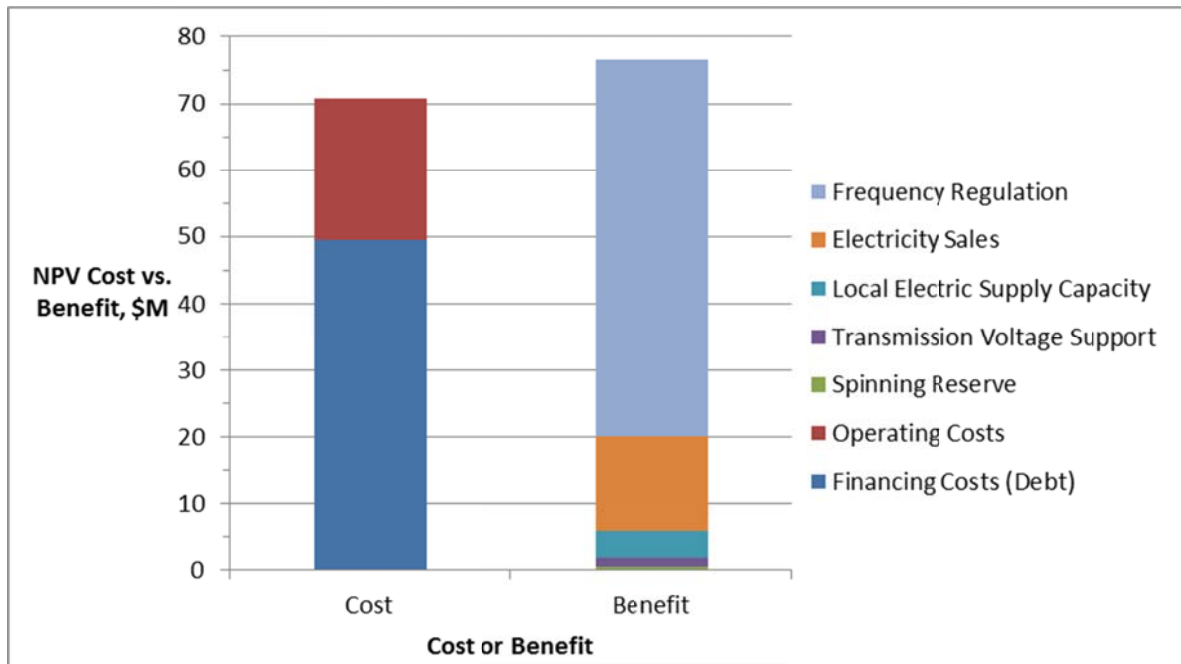

PSLF analysis performed on a 50 percent ramp over 1 minute at Beacon and Q09 (or full loss of generation at Beacon) was observed to have a minimal impact on the system frequency and voltage. Based on the results of this transient analysis, no changes to the sizing or cycles determined in the ramp rate control sizing analysis was determined to be necessary.

Since most of the value for this energy storage resource is derived from regulation, it is critical to ensure that the resource will be needed and used for frequency regulation. Therefore, it is recommended that LADWP regulation resource requirements be updated to reflect current and near term expected regulation resources and renewable energy installations. It should be noted that if regulation is removed from the ESVT model, the dispatch picks up other services in its place such as spinning reserves. This results in similar economics since the storage system is freed up to perform the other services. However, if regulation and spinning/non-spinning reserves are all removed, the storage system is not cost effective. This further solidifies the importance of being able to operate the storage system for many applications throughout the year.

In order to properly determine if a storage unit is cost-effective, the cost of alternatives to provide the same services must be considered. Although this is outside the scope of work for this study, Black & Veatch looked at a high level comparison to a combustion turbine providing similar services throughout the year. Based on previous work performed by Black & Veatch for LADWP on integration cost for solar and wind, the carrying cost of an LMS100 gas turbine is \$87/kW-yr and the operating cost, taking into account both upward regulation and fixed O&M, is \$55.30/MWh. Converting this to a levelized \$/ kW-yr value with expected dispatch from ESVT, and adding this to a typical fixed O&M cost of \$18/ kW-yr results in the following estimates.

	BEACON SOLAR	COPPER MOUNTAIN	Q09	LMS100 GAS TURBINE
Financing Costs (Debt), \$/ kW-yr	94.13	94.13	94.13	87.00 – 150.00
Operating Costs, \$/ kW-yr	40.66	40.48	40.57	20 – 30

Assuming both systems can operate in a similar fashion and provide the services under consideration, the benefits that the BESS and the gas turbine can capture are expected to be similar. If LADWP felt that sufficient combustion turbine capacity existing on its system to provide the regulating services needed for each solar plant, then development of new units for regulation may not be necessary. A more thorough comparison of the detailed costs of a combustion turbine providing these services is recommended which could consider in more detail responsiveness, costs, and emissions.

Battery Energy Storage at Olympic Receiving Station

Black & Veatch reviewed the LADWP provided 2013 Long-Term Transmission Plan which highlights two contingencies where 100-160 MW of load shedding is required to maintain compliance with NERC TPL standards. This is the only location identified by LADWP with transmission level load shedding concerns. For this reason, no other location was explored for battery siting to mitigate this issue.

At this location, the Scattergood-Olympic 230kV Cable A is already in the construction phase and a new high-side 230/34.5 kV transformer bank has been recommended by transmission

planners. Implementation of these efforts would be more economically viable than implementing a storage system. In addition, LADWP suggests this is a very low probability of occurrence event. As a result, a battery storage system at this location is not economically justifiable for it would rarely be used. This battery storage system would be too large for space constraints in this area as well. Black & Veatch does not recommend a battery storage system for this purpose at the Olympic Receiving Station.

Summary and Recommendations

To summarize, Black & Veatch recommends the following:

- Consider lithium ion based battery energy storage projects at one or more of the identified solar projects within the context of the costs of other resources to perform the same services.
- Update frequency regulation resource requirements to validate the level of need for future regulation and determine when this need may occur. If regulation requirements are expected to increase, the storage system could be considered to perform this service in lieu of using existing or additional regulation resources. If the increase in regulation requirements is not needed and other resources can perform this regulation service, energy storage will be less valuable.
- Continue with currently planned projects to mitigate overload contingencies at Olympic Receiving Station.

1.0 Introduction

As a result of California Assembly Bill 2514, California investor owned utilities (IOUs) are required to procure 1.325 GW of energy storage by 2020. Municipal utilities are required to self-declare economically viable energy storage targets for procurement in 2016 and in 2021. These targets along with the appropriate justification are due to the California Energy Commission by October 1, 2014. In support of this requirement, the Los Angeles Department of Water and Power (LADWP) retained Black & Veatch to analyze the costs and benefits of transmission system connected battery energy storage projects. Section 2 outlines analysis of the feasibility and cost-effectiveness of solar PV-sited Battery Energy Storage (BESS) system. Section 3 outlines analysis of the feasibility of a BESS used to mitigate load shedding at LADWP's Olympic Receiving Station.

1.1 DEFINITIONS

Battery energy storage is still a nascent industry and prior to diving into the analysis and results of this study it is helpful to define terms as they are utilized by Black & Veatch with regards to battery-based energy storage. Table 1-1 provides definition of key energy storage system terms while Table 1-2 provides definition of energy storage applications.

Table 1-1 Key Energy Storage Terms

TERM	DEFINITION
Power Rating	The rated power output of the entire energy storage system.
Energy Rating	The energy storage capacity of the entire energy storage system.
Discharge Duration	The typical duration that the energy storage system can discharge at its power rating.
Response Time	How quickly energy storage system can reach its power rating (typically in milliseconds) from zero power output.
Charge/Discharge rate (C-rate)	A measure of the rate at which the ESS can charge/ discharge relative to the rate at which will completely charge/ discharge the battery in one hour. A one hour charge/ discharge rate is a 1C rate. Furthermore, a 2C rate completely charges/ discharges the ESS in 30 minutes.
Round Trip Efficiency	The amount of energy that can be discharged from an energy storage system relative to the amount of energy that went into the battery during charging (as a percentage).
Depth of Discharge (DoD)	The amount of energy discharged as a percentage of its overall energy rating.
State of Charge (SOC)	The amount of energy an energy storage resource has charged relative to its energy rating, noted as a percentage.
Cycle Life	Number of cycles before ESS reaches 80 percent of initial energy rating. The cycle life can vary for various DoDs.

TERM	DEFINITION
Maximum Allowed Ramp Rate, % of Facility Capacity	This is the maximum ramp rate in kW or MW/ min that is allowed from the generation set being analyzed using the Ramp Rate Control objective function.
Ramp Rate Compliance, %	Percent of non-zero time intervals that the generating facility is in compliance with the prescribed ramp rate limitation
Droop	Slope of the frequency-power curve for ESS performing frequency regulation
Deadband	Region where ESS doesn't respond to frequency deviations from nominal
Energy Storage System (ESS)	The ESS consists of the battery modules as well as the racking and electrical connections between the modules/ racks.
Power Conversion System (PCS)	The PCS is a bi-directional converter that converts AC to DC and DC to AC. The PCS also communicates with the BMS and BESS controller.
Battery Management System (BMS)	The BMS can be comprised of various BMS units at the cell, module and system level. The BMS monitors and manages the battery SOC and charge and discharge of the ESS.
BESS/ Site Controller	The BESS controller communicates with all the components and is also the utility communication interface. Most of the advanced algorithms and control of the BESS resides in the BESS/ Site Controller.

Table 1-2 Energy Storage Applications

APPLICATION	DEFINITION
Ramp rate control	Ramp rate control can be used to limit the ramp rate of a variable energy resource to limit the impact to the grid. For example, energy storage may be used to limit the fluctuation in output from a PV plant.
Frequency regulation	The use of energy storage to mitigate load and generation imbalances on the second to minute interval to maintain grid frequency.
Capacity firming	The use of energy storage to firm energy generation of a variable energy resource so that output reaches a specified level at certain times of the day. This is done in order to match peak generation to peak load times and to avoid curtailment of the renewable generation resource.
System capacity	The use of energy storage to provide peak system capacity during peak hours.
Electrical energy time-shift	The use of energy storage to purchase energy when prices are low and shift that energy to be sold when prices are higher (during peak times). This is sometimes called energy arbitrage.
Voltage support	The use of the energy storage power converter to provide or absorb reactive power for voltage support and respond to voltage control signals from the grid.
Spinning reserve	The use of energy storage that is online and synchronized to supply generation capacity within 10 minutes.

APPLICATION	DEFINITION
Non-spinning reserves	The use of energy storage that is offline but can be ramped up and synchronized to supply generation capacity within 10 minutes.
Peak load shaving	The energy storage system can limit the load at a particular location on the utility system in order to avoid load shedding or the need to upgrade the transmission or distribution system.

1.2 SOFTWARE TOOL SUMMARY

Black & Veatch employed two energy storage modeling tools as well as a power flow tool to support the analysis for this study. Black & Veatch’s proprietary energy storage technical model, SmartES, was used for sizing (power and energy) and feasibility. EPRI’s dispatch model Energy Storage Valuation Tool (ESVT) was used to perform cost benefit analysis of the storage systems defined with SmartES. PSLF, a load flow and dynamic modeling tool, was used to investigate the frequency and voltage impacts to extreme PV ramping scenarios. The capabilities of these tools are summarized in Table 1-3.

Table 1-3 Software Tool Capabilities

SmartES	ESVT	PSLF
<ul style="list-style-type: none"> • Detailed performance model for multiple applications: <ul style="list-style-type: none"> • Frequency regulation • Peak shaving • Capacity firming • Ramp rate control • Electrical energy time-shift • Custom applications • Uses including: <ul style="list-style-type: none"> • Capacity and energy sizing • Technology studies • Interconnection requirement compliance • Cycle life / lifetime estimation for economic modeling 	<ul style="list-style-type: none"> • Economic dispatch model for a variety of applications including: <ul style="list-style-type: none"> • System capacity • Electrical energy time-shift • Frequency regulation • Spinning reserves • Non-spinning reserves • Voltage support • Investment upgrade deferral • Others • Economic analysis provided: <ul style="list-style-type: none"> • NPV cost benefit analysis • Detailed financials • Dispatch information 	<ul style="list-style-type: none"> • Load flow analysis • Dynamic simulation/transient analysis • Short circuit analysis • Interconnection and impact studies • System stability studies

2.0 Battery Energy Storage at Three Solar Projects

Black & Veatch assessed the feasibility of battery storage at the following three solar PV facilities. The rated capacities shown below were used in this analysis.

- Beacon Solar Plant: 350 MW
- Q09 Solar Project: 200 MW
- Copper Mountain Solar Project: 250 MW

2.1 ANALYSIS METHODOLOGY

Primary sizing was determined to be made based on renewables integration (ramp rate control) rather than capacity firming or capacity contribution since the battery storage systems under consideration are at solar PV plants and a considerable number of renewables are expected in the coming years. Often strict ramp rate limitations are put on generators in island systems. For example, Hawaiian Electric generator performance requirements include a 10 MW per minute ramp rate limitation for 200 MW generator facilities such as solar PV. Mainland US projects are exploring similar ramp rate control methods. Public Service of New Mexico's Prosperity Electricity Storage Project demonstrated a 70 percent reduction in maximum solar PV swings with a "smoothing" PV battery system.¹ Other large energy storage projects are addressing a lithium ion battery's ability to provide renewable energy smoothing or ramp rate control. These include the AES Energy Storage 32 MW Laurel Mountain project that is simultaneously addressing ramp rate control and frequency regulation.² Southern California Edison is also demonstrating a lithium ion battery's ability to perform multiple applications such as ramp rate control of wind energy and frequency regulation (among other applications).³ Finally, Germany which has a significant amount of solar PV generation limits positive ramp rates to 10 percent.⁴

Based on this experience, Black & Veatch used the following methodology to analyze energy storage for these three solar PV plants.

- The size of projects and expected applications for energy storage were first reviewed to come up with a technology selection.
- SmartES was used to determine the initial size of the energy storage systems (both power and energy rating) based on ramp rate control.
- PSLF and SmartES were used for frequency analysis. SmartES was used to model how a storage system would respond to infrequent yet extreme disturbances. PSLF was used to look at ramp rate disturbances on frequency at short time intervals (less than a second).

¹ Dakota Roberson, James F. Ellison, Dhruv Bhatnagar, and David A. Schoenwald, "Performance Assessment of the PNM Prosperity Electricity Storage Project." May 2014. <http://www.sandia.gov/ess/publications/SAND2014-2883.pdf>

² DOE Global Energy Storage Database, Laurel Mountain Project. <http://www.energystorageexchange.org/projects/164>

³ DOE Global Energy Storage Database, Southern California Edison Tehachapi Wind Energy Storage Project. <http://www.energystorageexchange.org/projects/8>

⁴ Vahan Grevorgian and Sarah Booth, "Review of PREPA Technical Requirements for Interconnecting Wind and Solar Generation." November 2013, <http://www.nrel.gov/docs/fy14osti/57089.pdf>

- Capital cost is then estimated for the identified projects.
- Finally, ESVT is used to optimize dispatch of primary and secondary applications and to determine the overall project economic viability.

2.2 ENERGY STORAGE TECHNOLOGY SELECTION

Black & Veatch was tasked with examining battery storage facilities sited at the previously mentioned solar facilities. While assessing other technologies is outside the tasks included in this scope of work, Black & Veatch and LADWP have agreed that battery based energy storage is the most viable option to consider for these projects. Other technology options such as flywheels have limited commercial availability and limited demonstrated experience. Compressed Air Energy Storage (CAES) or pumped storage hydro are much larger in scale than the projects in consideration for this report, are geographically limited and have other drawbacks such as long development times and high development costs.

The primary applications expected for these storage systems are ramp rate control and frequency regulation. Based on the solar plant sizes and expected applications, lead acid systems can be omitted due to insufficient cycle life for frequency regulation and renewable integration applications. Flow batteries, sodium sulfur, and sodium nickel batteries are excluded as they are more suited for longer duration energy applications such as shaving peak load or time-shifting large amounts of energy. Black & Veatch believes that lithium ion is the ideal technology for this system. This technology offers the following benefits:

- **Excellent cycle life:** Lithium ion technologies have superior cycling ability to other battery technologies such as lead acid.
- **Fast response time:** Black & Veatch selected lithium ion technology due to its fast response time which is typically less than 100 milliseconds.
- **Sustainability:** Lithium ion batteries can be recycled at the end of life by returning to the battery supplier.
- **High round trip efficiency:** Lithium ion energy conversion is efficient and has a 90 percent round trip efficiency (DC-DC).
- **Versatility:** Lithium ion solutions can provide the relevant operating functions frequency regulation, ramping, renewable integration, load following, voltage support and spinning reserve.
- **Availability:** Black & Veatch maintains relationships with dozens of strong lithium ion vendors.
- **Energy Density:** Lithium ion solutions have a high energy density to meet space constraints.

A lithium ion BESS typically includes batteries, PCS, BMS, HVAC, and fire suppression in a containerized or skid mounted turnkey solution. Key lithium ion performance characteristics are summarized in the table below.

Table 2-1 Lithium Ion Battery Performance Table

PARAMETER/ TERM	LITHIUM ION BATTERY
Power rating, MW	0.005 to 32
Energy rating, MWh	0.005 to 32
Discharge duration, hours	0.25 to 4
Response time, milliseconds	< 100
Round trip efficiency, %	75 to 90
Cycle life, cycles at 80 % DoD	1,200 to 4,000
Cycle life, cycles at 10% DoD	60,000 to 200,000

2.3 DATA PRE-PROCESSING

This section discusses high level data processing that went into the technical analysis. The following high level steps were taken to process the data before performing the analysis. The data was obtained from LADWP through rigorous and collaborative data request process. Economic analysis data will be discussed in the later economic analysis sections.

- The data was re-arranged to into a single column for timestamps and single column for power generation.
- As per SmartES requirements the power generation was converted from MW to W.
- It was made sure through additional formatting that the power generation data did not contain any decimal values.
- February was removed from the analysis due to inconsistency and data quality issues with the commissioning process.
- Similar quality issues were found to occur beyond February. Therefore, ramps above roughly 50 percent were removed from the data set. Still some unrealistic ramps may be included.

2.4 RAMP RATE CONTROL ANALYSIS

To determine the sizing for ramp rate control, it is preferred that real data is used to accurately capture the variability of the solar resource. Therefore, Black & Veatch's approach was to use high resolution data from Pine Tree Solar Facility and Copper Mountain that was provided by LADWP. The data provided for the 9 MW Pine Tree Facility was for over a year's worth of minute data and 36 days for the 48 MW Copper Mountain project. These 36 days of data showed an even representation of variable, intermediate and smooth days. Black & Veatch took a conservative approach and assumed the Copper Mountain data provided is representative of the entire plant operation and variability throughout the year. This means that the same number of variable days was analyzed as the number of clear days which is a conservative estimate. Based on Black & Veatch's experience in Puerto Rico, Hawaii and the other mainland United States locations described earlier, ramp rate limitations of 10 percent and 15 percent of the solar PV capacity (per

minute) were explored. To try to meet these ramp rate limitations within a certain percentage of the time (in this case 99 percent of the time – also called ramp rate compliance), Black & Veatch analyzed battery storage systems sized at 10 percent and 20 percent of the PV capacity.

Black & Veatch used a power to energy ratio of 2:1 or systems rated for 2C charge and discharge rates based on the availability of these systems and experience with the typical requirements for this application. Analysis at the previously prescribed ramp rate limitations and BESS sizes is outlined in Table 2-2 for Pine Tree and Table 2-3 for Copper Mountain. The base case outlined below shows the ramp rate compliance of just the solar PV generation before a storage system. This means that the solar PV facility initially has a certain level of compliance, depending on the ramp rate limitation considered.

Table 2-2 Pine Tree Solar Analysis

RAMP RATE LIMITATION, % OF PV AC RATING	RAMP RATE COMPLIANCE, %	BESS SIZING, % OF PV AC RATING	BESS POWER, MW	BESS ENERGY, MWH	ESTIMATED CYCLES FROM 0 TO 10% DOD PER YEAR	ESTIMATED CYCLES FROM 10 TO 20% DOD PER YEAR
10 (base case solar – no BESS)	97.5%	NA	NA	NA	NA	NA
10	99.7%	10	0.9	0.45	1537	67
10	99.7%	20	1.8	0.9	1573	30
15 (base case solar – no BESS)	98.8%	NA	NA	NA	NA	NA
15	99.7%	10	0.9	0.45	870	11
15	99.9%	20	1.8	0.9	880	1

An example screen shot of a variable day from Pine Tree Solar SmartES analysis is shown in Figure 2-1. The plot includes original PV generation and PV generation that has been controlled by the BESS under consideration (in this case a 10 percent BESS).

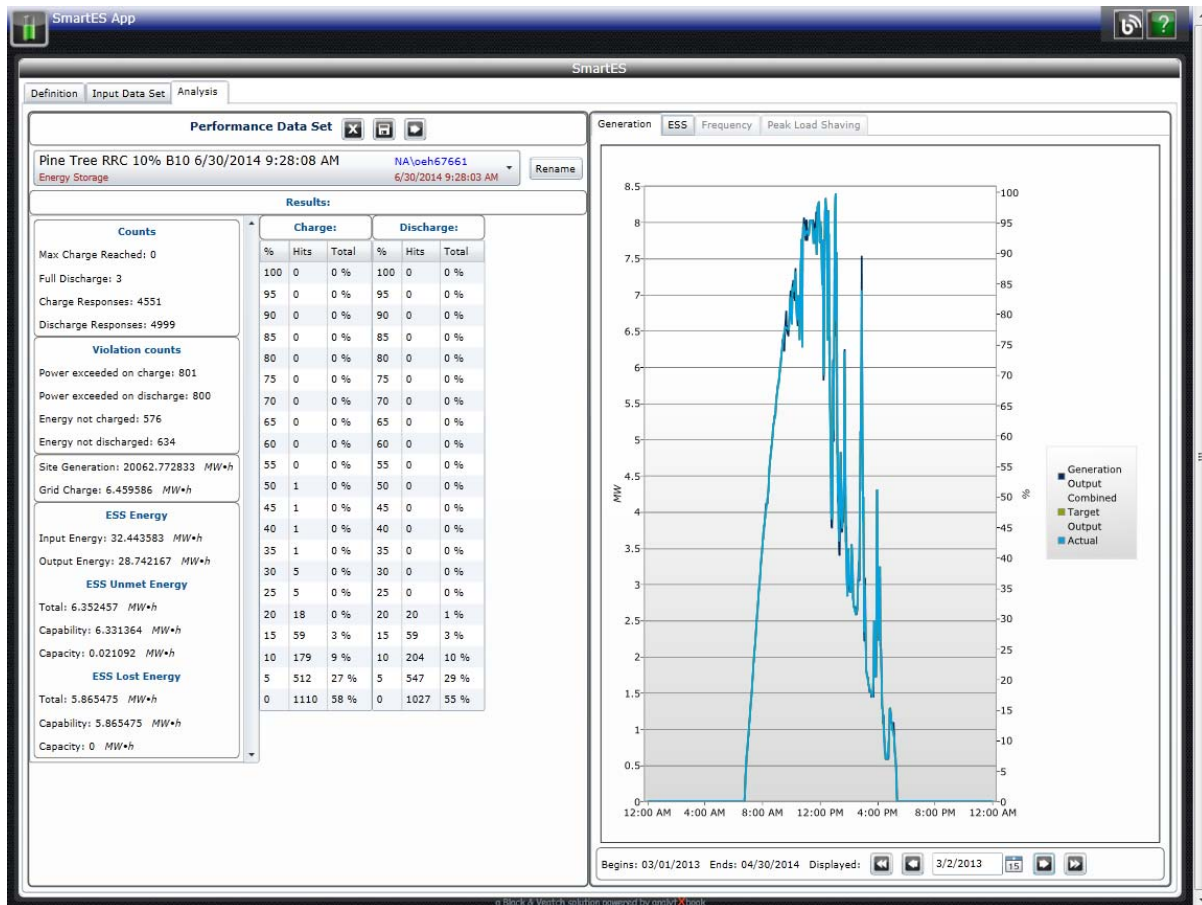

Figure 2-1 SmartES Screenshot of Variable Day from Pine Tree Solar Analysis

An example screenshot from SmartES showing the BESS response for the variable day of Pine Tree Solar generation is shown in Figure 2-2. The plot includes the BESS response performing ramp rate control and the SOC.

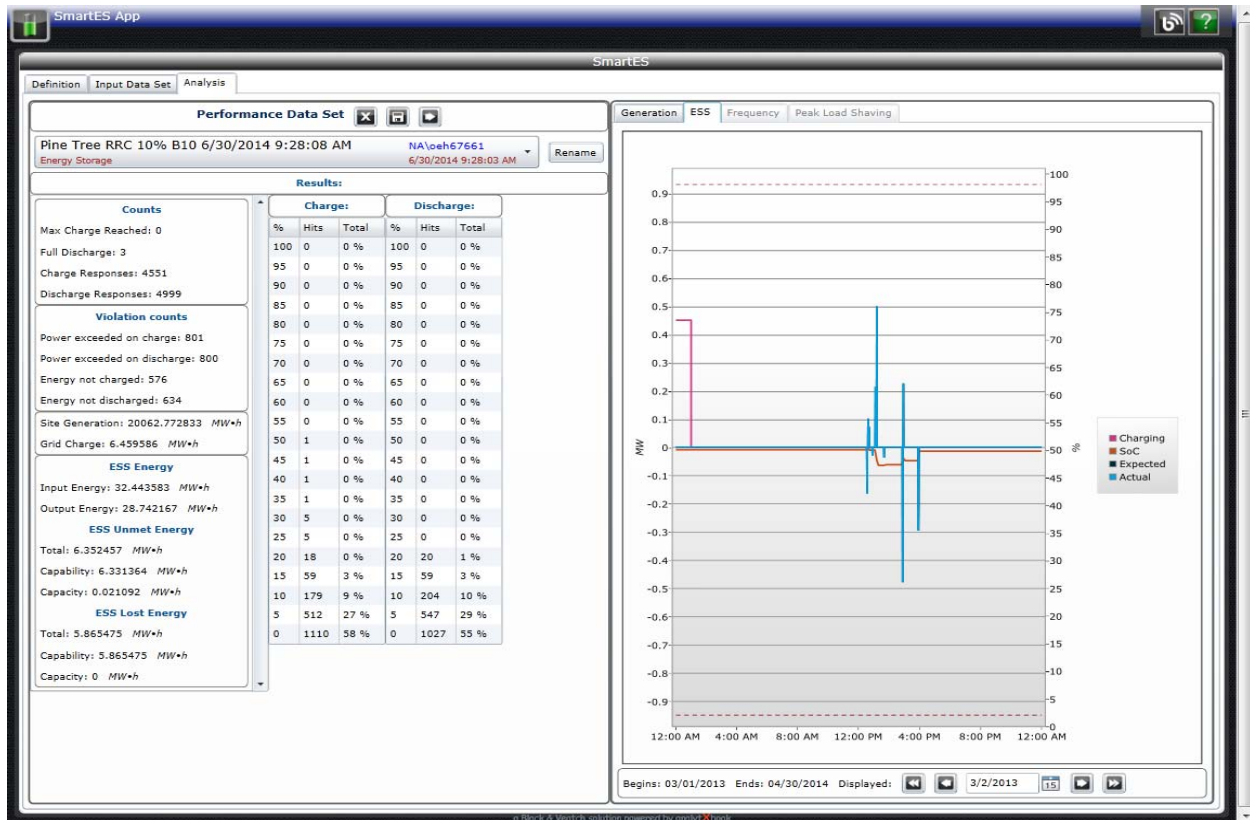

Figure 2-2 SmartES Screenshot of BESS Response from Pine Tree Solar

Table 2-3 Copper Mountain Analysis

RAMP RATE LIMITATION, % OF PV AC RATING	RAMP RATE COMPLIANCE, %	BESS SIZING, % OF PV AC RATING	BESS POWER, MW	BESS ENERGY, MWH	ESTIMATED CYCLES FROM 0 TO 10% DOD PER YEAR	ESTIMATED CYCLES FROM 10 TO 20% DOD PER YEAR
10 (base case solar – no BESS)	97.2%	NA	NA	NA	NA	NA
10	99.2%	10	4.8	2.4	2236	132
10	99.7%	20	9.6	4.8	2322	46
15 (base case solar – no BESS)	98.8%	NA	NA	NA	NA	NA
15	99.6%	10	4.8	2.4	1212	25
15	99.9%	20	9.6	4.8	1242	0

An example screen shot of a variable day from Copper Mountain SmartES analysis is shown in Figure 2-3. The plot includes original PV generation and PV generation that has been controlled by the BESS under consideration (in this case a 10 percent BESS).

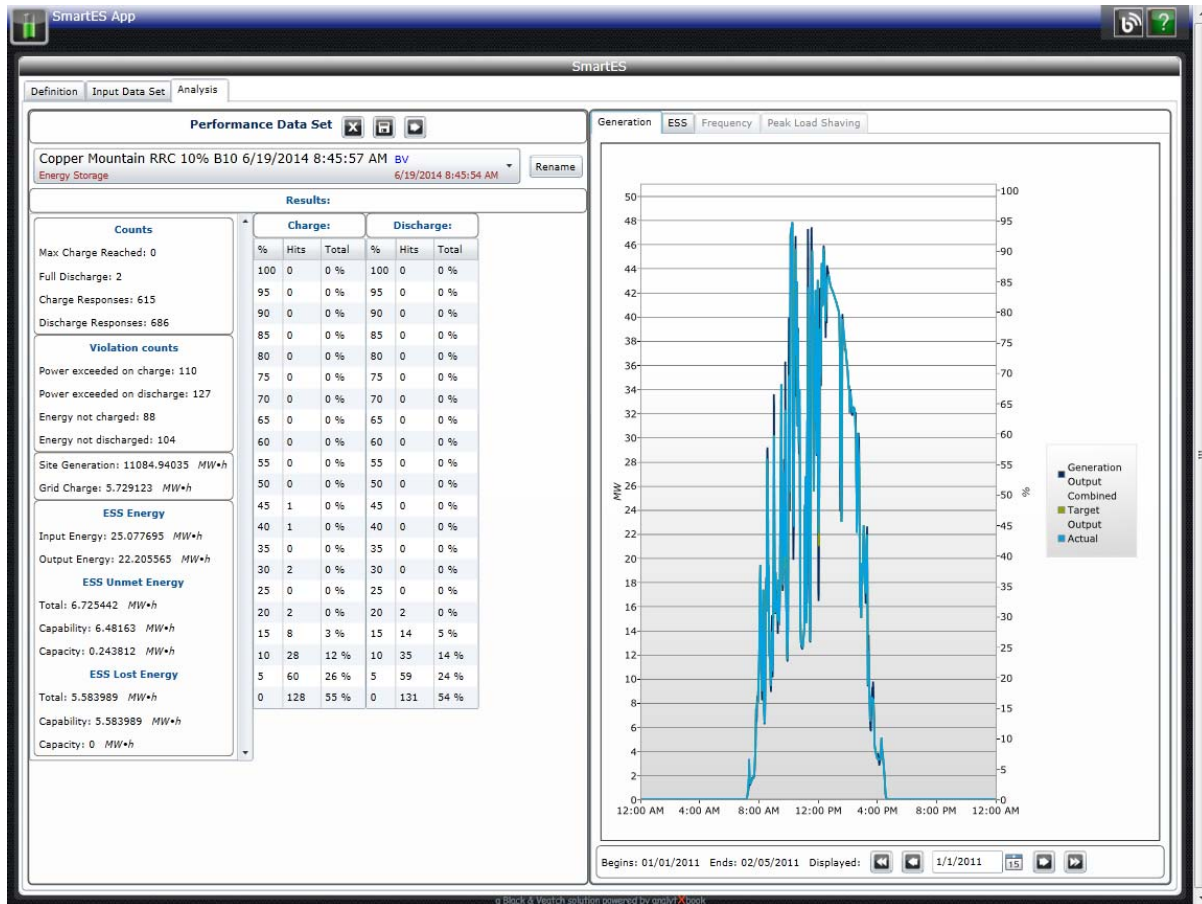

Figure 2-3 SmartES Screenshot of Variable Day from Copper Mountain Solar

An example screenshot from SmartES showing the BESS response for the variable day of Copper Mountain generation is shown in Figure 2-4. The plot includes the BESS response performing ramp rate control and the SOC.

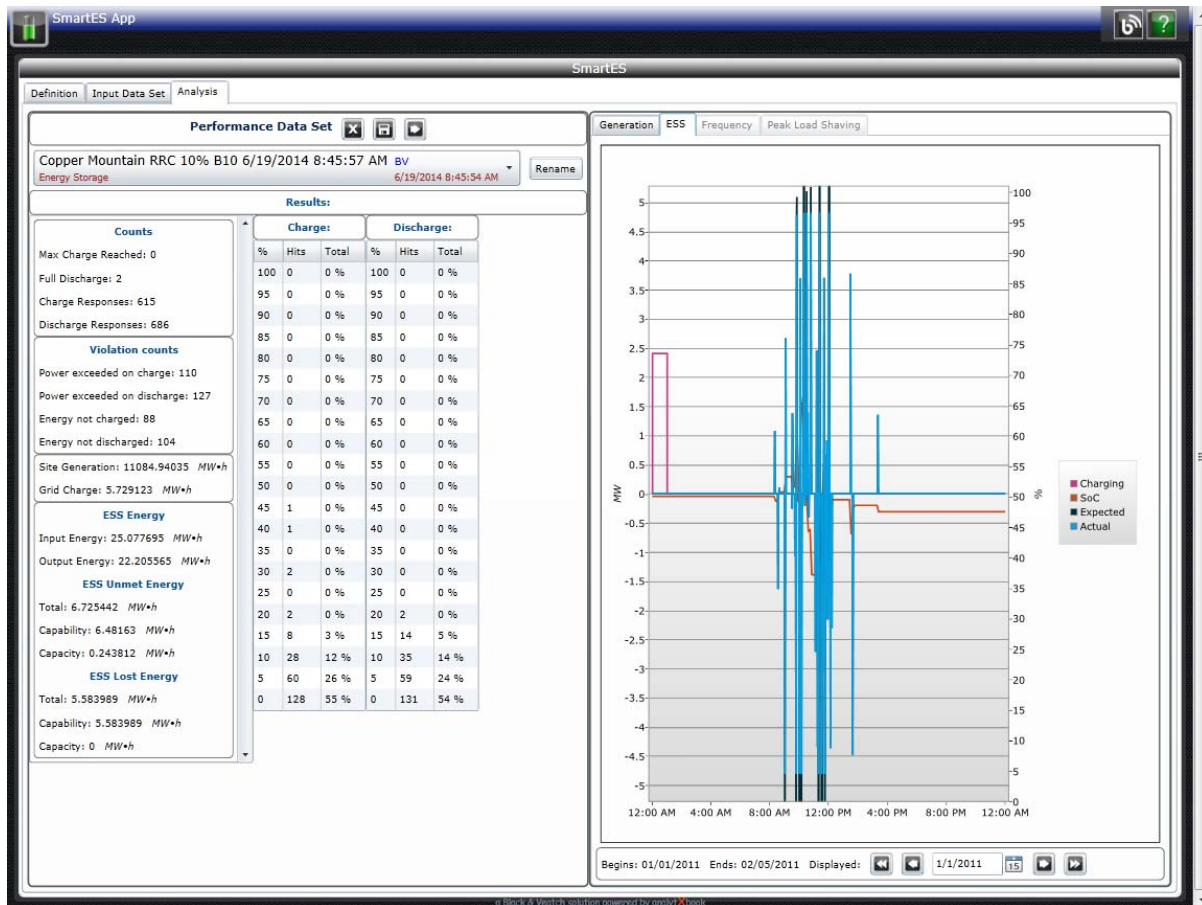

Figure 2-4 SmartES Screenshot of BESS Response for Copper Mountain Solar

Included in the analysis for these two solar plants is the number of cycles incurred by the BESS while performing ramp rate control. Note that these cycles are modeled and should be confirmed with each particular vendor for each application and each project.

The results show that for 15 percent ramp rate compliance, the solar generation is already in compliance 98.8 percent of the time for both Pine Tree and Copper Mountain. Therefore, to make a significant impact, a ramp rate level of 10 percent is recommended. It can also be seen that reasonable ramp rate compliance can be obtained with a BESS sized at 10 percent of the PV facility (versus 20 percent). Therefore, a BESS sized at 10 percent of the PV facility should be sufficient, and is estimated to result in a compliance of greater than 99 percent.

Based on the analysis shown in the two tables above, Black & Veatch can estimate the BESS sizing required for the entire Copper Mountain facility as well as the other two PV plants studied in this report. The sizing outlined in Table 2-4 is expected to obtain a compliance of 99 percent or greater. The table also shows the estimate cycles at 0 to 10 percent DOD. Cycles greater than 10 percent DOD were ignored for this study as there were very few cycles larger than 10 percent and do not significantly affect the lifetime of the system.

Table 2-4 BESS Sizing and Cycles for Ramp Rate Control

PLANT	RAMP RATE COMPLIANCE, %	BESS POWER, MW	BESS ENERGY, MWH	ESTIMATED CYCLES AT 0 TO 10 % DOD PER YEAR
Copper Mountain Solar (250 MW)	EXPECTED > 99.0%	25	12.5	1500-2500
Beacon Solar (350 MW)	EXPECTED > 99.0%	35	17.5	1500-2500
Q09 Solar Project (200 MW)	EXPECTED > 99.0%	20	10	1500-2500

2.5 FREQUENCY REGULATION ANALYSIS

Frequency regulation analysis is described in two sections below with the first addressing the impact of the proposed battery storage facilities providing additional frequency regulation on top of the existing assets providing regulation services. The second takes a look at the potential system frequency impacts of large uncontrolled ramps of the solar facilities and what, if any, impact that has on the energy storage system sizing.

2.5.1 SmartES Frequency Regulation Analysis

For frequency regulation analysis, Black & Veatch requested frequency data that gives a good indication of both the extreme regulation up and regulation down scenarios. Additionally, Black & Veatch examined more typical days during the same seasons that the extreme scenarios occurred. LADWP provided the following data used in this analysis:

- Spring (April) data for regulation down expectations: typical days were provided as well extreme cases. This data potentially had instances where load reduced significantly and therefore resources were instructed to provide regulation down (the BESS would be charging in this instance).
- Summer (August) data for regulation up expectations: typical days were provided as well as extreme cases. This data potentially had instances where load increased significantly and therefore resources were instructed to provide regulation up (the BESS would be discharging in this instance).

For convenience of analysis, the time based data provided by LADWP dates were combined to create a single dataset. Frequency regulation was simulated with a droop of 1.0 percent and deadband of 0.1 percent. For each plant, 2C or 30 minute duration batteries were explored as a starting point. Since ramp rate control was only expected to occur 1 to 2 percent of the non-zero time intervals for the PV facilities, the power rating for frequency regulation was kept the same due to the small likelihood that these two functions will need to be performed at the same time. Increases in energy rating were explored but determined to not be necessary for frequency regulation.

The results of SmartES analysis are shown in Table 2-5 and Figure 2-5. Due to the fact that the frequency data analyzed has already been regulated within LADWP’s system, the results

represent only minimal additional battery cycles to mitigate the more extreme frequency disturbances.

Table 2-5 SmartES Frequency Regulation Cycles

PLANT	BESS POWER, MW	BESS ENERGY, MWH	ESTIMATED CYCLES FROM 0 TO 10% DOD PER YEAR
Copper Mountain Solar (250 MW)	25	12.5	1000-1100
Beacon Solar (350 MW)	35	17.5	1000-1100
Q09 Solar Project (200 MW)	20	10	1000-1100

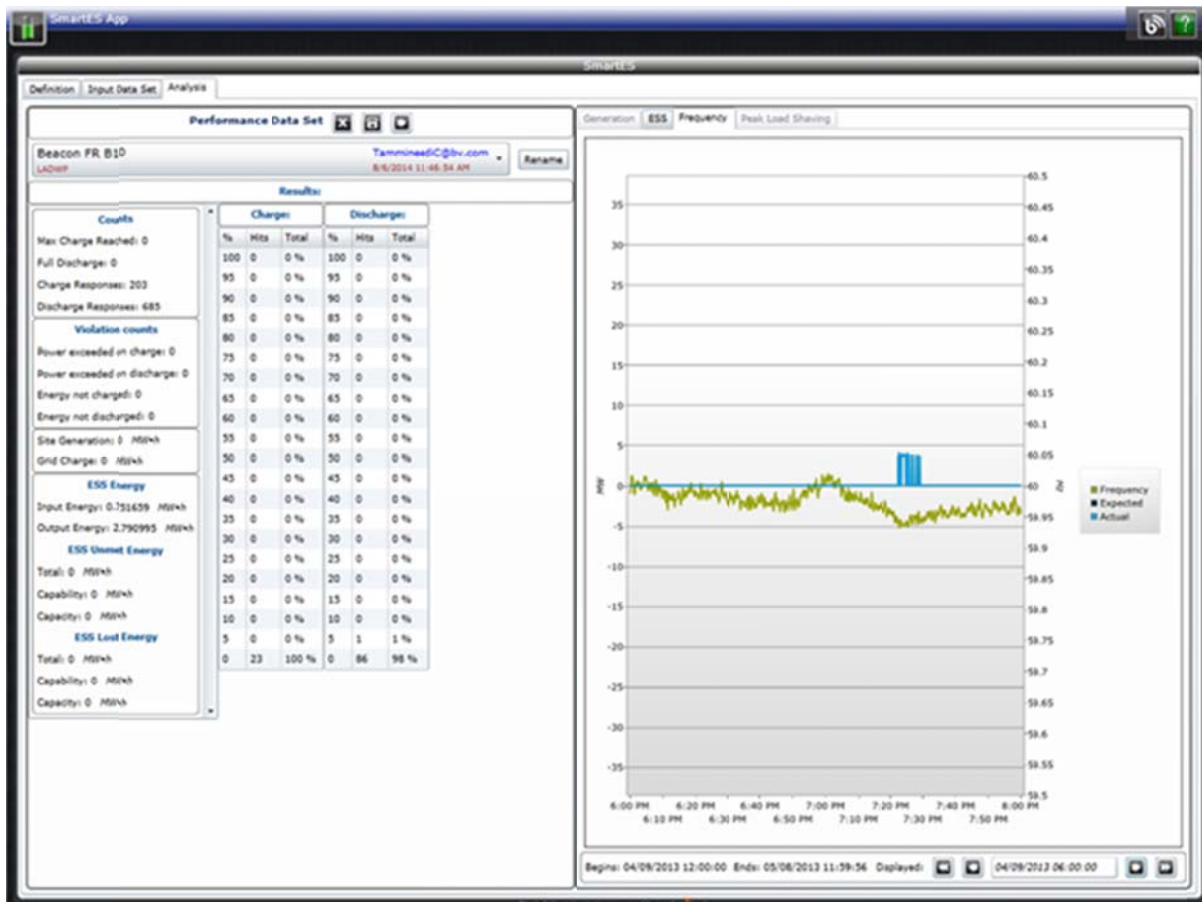

Figure 2-5 Screenshot of Frequency Regulation Analysis and BESS Output/SOC

2.5.2 System Frequency Analysis

To address the impact of extreme ramping events at the Beacon Solar and Q09, Black & Veatch performed a transient stability analysis using PSLF to investigate the potential impacts on system voltage and frequency. A simultaneous 50 percent ramp over the course of a minute was studied

per discussions with LADWP to simulate a worst case scenario of cloud variability. The selection of a 50 percent ramp over a minute is a very conservative approach given the size of the solar plants.

The Beacon Solar plant was studied at a capacity of 600 MW in this frequency analysis to account for the potential of future development. The capacity was split between the Beacon A and B 34.5 kV switchyards as shown in Figure 2-6. The 0.29/34.5 kV and 34.5/230 kV step up transformers were modeled as 320 MVA units with a 5% impedance, 45 X/R ratio and nominal tap settings.

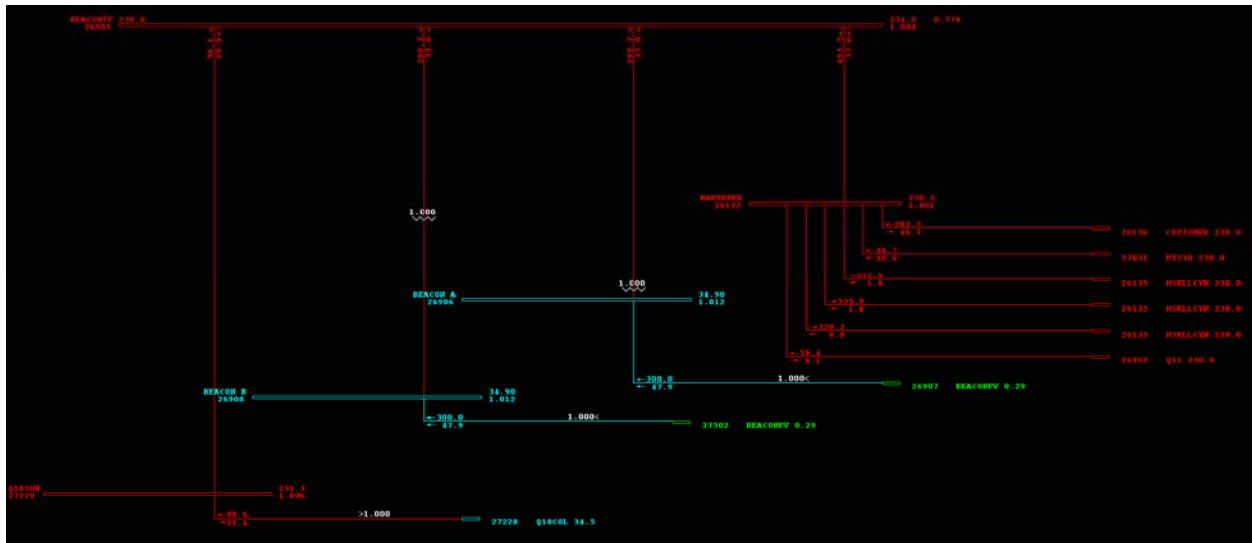

Figure 2-6 Beacon Solar – Increased Capacity

Q09 was studied at 200 MW. Cloud cover was studied at both plants simultaneously. In addition to studying the impacts of an extreme ramped reduction, Black & Veatch studied the impact of an instantaneous loss of Beacon Solar. The analysis consisted of the following scenarios:

- CASE 1: Simultaneous 50 percent ramp over 1 minute at Beacon Solar and Q09
- CASE 2: Trip all of Beacon Solar (600 MW to account for future development)

The voltage and frequency was monitored at the following locations for each scenario studied:

- Beacon A 34.5 kV Bus
- Beacon B 34.5 kV Bus
- Beacon Tap 230 kV Bus
- Q09 34.5 kV Bus
- Q09 230 kV Bus

2.5.2.1 Results

The frequency and voltage plots for the above scenarios are shown in Figure 2-7 through Figure 2-10:

CASE 1: Simultaneous 50% Ramp Down at Beacon and Q09

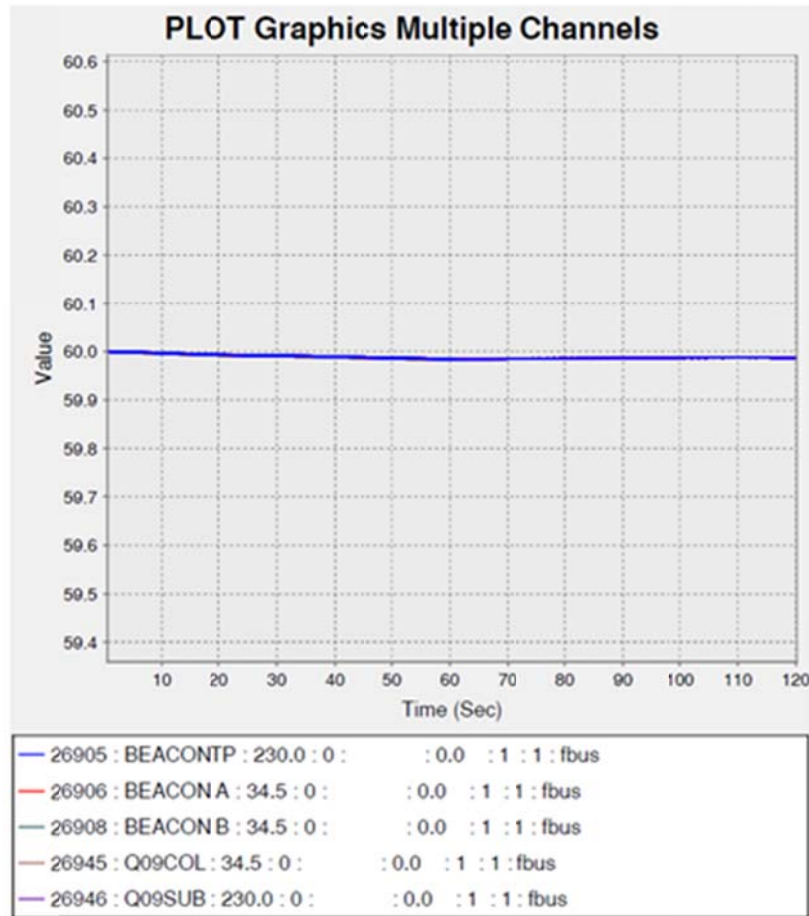

Figure 2-7 50% Ramp Over 1 Minute – Frequency Plots, Value=Hz

The ramped reduction in real power output at Beacon and Q09 simultaneously result in a minimal frequency deviation (0.017 Hz). The results indicate that the ramped reduction in real power output of Beacon and Q09 will not have an impact on the system frequency.

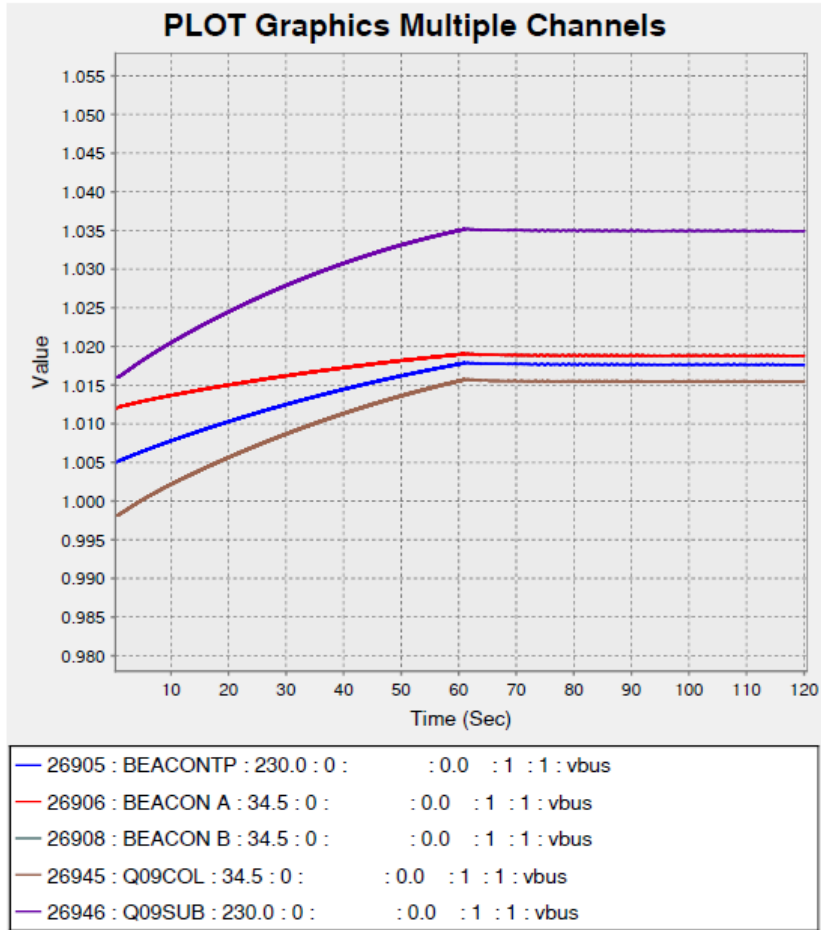

Figure 2-8 50% Ramp Over 1 Minute – Voltage Plots, Value=per-unit

The following voltage increases were observed due to the ramped reduction in real power output at Beacon and Q09:

- Beacon 230 kV Bus: 1.4%
- Beacon A and B 34.5 kV Bus: 0.8%
- Q09 34.5 kV Bus: 1.8%
- Q09 230 kV Bus: 2.0%

The ramped reduction in real power output reduces the current flow through the 0.29/34.5 kV and 34.5/230 kV step-up transformers. The voltage drop through the transformers is proportional to the product of the current and the impedance. Hence the reduced current flow through the transformers lessens the voltage drop at each bus (which is perceived as a voltage increase). This voltage change is well within normal operating limits.

CASE 2: Trip Beacon:

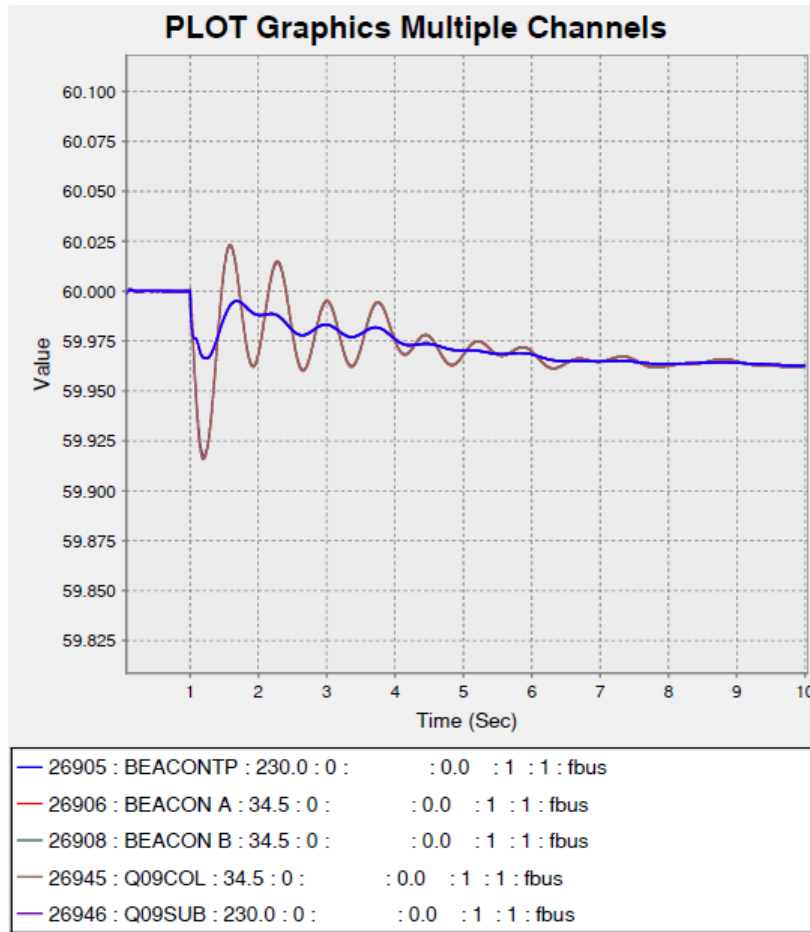

Figure 2-9 Trip Beacon – Frequency Plots, Value=Hz

The instantaneous tripping of Beacon results in a frequency deviation of 0.037 Hz at Beacon. Following the outage of Beacon, the frequency at Q09 undergoes minor oscillations with a minimum and maximum spread of 59.9 and 60.02 Hz respectively. The frequency oscillations damped out to 59.96 Hz (i.e. a 0.037Hz deviation). These frequency oscillations are minimal; therefore, the instantaneous loss of the Beacon does not have an impact on the system frequency.

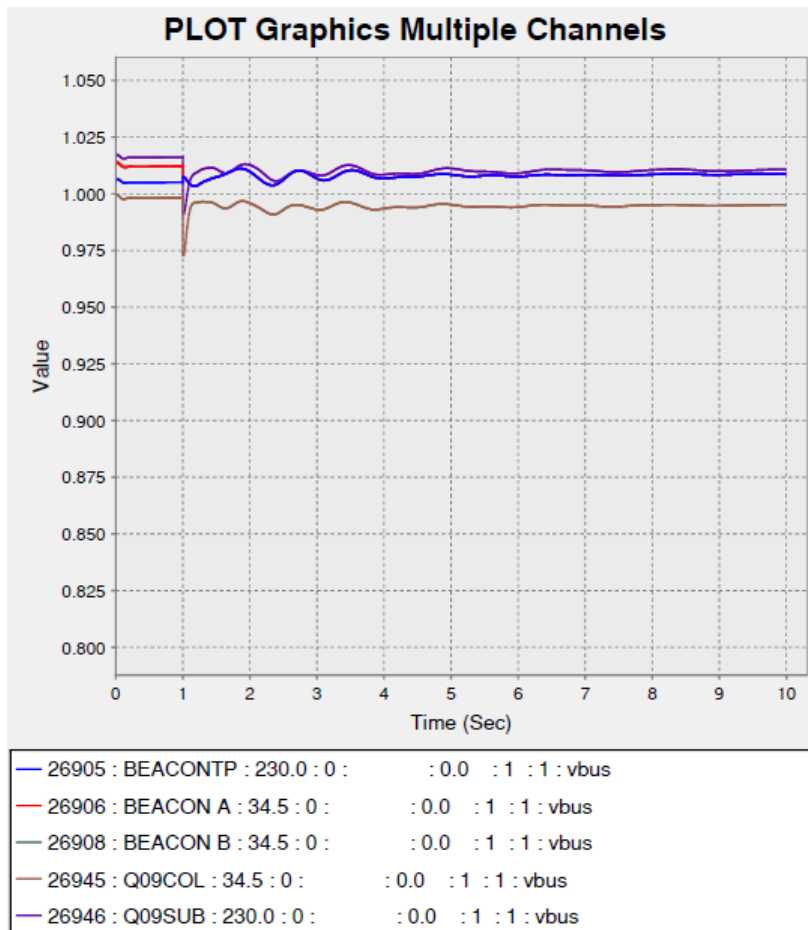

Figure 2-10 Trip Beacon – Voltage Plots, Value=per-unit

The instantaneous loss of generation at Beacon results in a negligible change in the voltage at the Beacon and Q09. Immediately following the outage, the voltage dips, but quickly recovers to a new steady-state value. The largest voltage dip was observed at the Q09 34.5 kV bus (0.973 per-unit, a 0.025 per-unit decrease). The largest percent change between initial and final value (i.e. once the voltage has reached a new steady-state value) was observed at the Beacon 230 kV bus (0.005 per-unit). The results indicate that the loss of generation at Beacon has a negligible impact on the system voltage.

2.5.2.2 Conclusions and Recommendations

The loss of generation at Beacon or Q09 whether it be due to ramped reduction (i.e. cloud cover) or a plant trip event was observed to have a minimal impact on the system frequency and voltage. Based on the results of this transient analysis, no changes to the BESS sizing are warranted, therefore, the proposed BESS capacity from ramp rate control requirements is not modified and no additional frequency disturbance analysis is warranted.

2.6 SYSTEM CAPACITY ANALYSIS

Black & Veatch will not make sizing modifications using SmartES for solar PV capacity firming and capacity contribution. This is because most of the value and the main application the storage system will economically perform is frequency regulation. Therefore, sizing the system to meet this requirement will be the basis for this analysis and this size will be used for capacity applications when available.

Based on Black & Veatch's experience and past economic analyses performed, additional energy storage capacity to fulfil only system capacity applications will not be economically viable. This was confirmed with initial ESVT runs since this tool is new to the industry and the results verified Black & Veatch's expectations.

Solar PV capacity firming was not explored in this analysis since this is not expected to be an economically viable option for LADWP.

2.7 ECONOMIC ANALYSIS

This section outlines the economic analysis that Black & Veatch performed with ESVT.

2.7.1 Cycle Life and Degradation

An important aspect of economic modeling is the expected degradation of the storage system and therefore yearly degradation due to the cycling nature of the studied applications. Black & Veatch performed some preliminary ESVT dispatch analysis to confirm the primary application the storage system is providing is frequency regulation. However, a limitation of ESVT is that the software will not calculate inter-hourly cycling from the energy storage system. In order to estimate the cycles incurred from both ramp rate control and frequency regulation, Black & Veatch combined the lower end of the expected ramp rate control cycles (1,500 10 percent DOD cycles per year) with the below estimate for frequency regulation cycles.

For the frequency regulation cycling estimate, Black & Veatch assumes that the cycling requirements for operating the BESS for frequency regulation most hours of the year results in about two 10 percent DOD cycles per hour of the year. Assuming approximately 150,000 cycle life at 10 percent DOD based on lithium ion technology performance specifications, this results in a 2.3 to 2.5 percent degradation per year and a replacement in the 7-8 year timeframe. Black & Veatch assumed a 15 year project lifetime which is a reasonable expectation based on EPC work Black & Veatch is involved in. This information is used for degradation assumptions in the economic analysis.

2.7.2 Capital Costs

Black & Veatch leveraged its EPC experience in the energy storage industry and knowledge of energy storage manufacturers to provide high level costs for lithium ion batteries. In addition to this, Black & Veatch utilized a report produced by Sandia National Laboratories titled "DOE/EPRI Electricity Storage Handbook in Collaboration with NRECA" to compare costs. Included in this report are estimates for certain costs based on a survey that the report writers conducted to a

number of vendors. These survey results (which are anonymous and not tied to any particular vendor) coupled with Black & Veatch’s database of nearly 100 vendors provide for sufficient cost estimates for this level of study. Finally, the DOE Global Energy Storage Database was also used which is a compilation of many existing energy storage projects.

The capital costs outlined below are the total installed costs and include all energy storage equipment as well as all the installation and interconnection costs. The interconnection costs are outlined based on a typical percentage range of the overall capital costs of the particular project and include any costs incurred from the output of the PCS (of the BESS) to the interconnection. This includes the balance of plant costs for engineering and equipment. The cost of fixed and variable O&M for lithium ion storage is shown in Table 2-6.

Table 2-6 Degradation and Capital Cost Summary

PARAMETER	VALUE
Installed Capital Cost, \$/ kW	1,100
Installed Capital Cost, \$/ kWh	2,200
Interconnection cost, \$/kW	500
Fixed O&M, \$/ kW-yr	10
Variable O&M, \$/kWh	0.002
Replacement Costs, \$/kWh	600
Degradation, %	2.3 – 2.5
Estimated cycles per year	17,500 to 19,000 at 10 % DoD
Expected year of replacement	7 to 8 years

2.7.3 Dispatch Optimization via ESVT

For the economic analysis of the battery storage systems sited at each of the solar PV facilities of interest, Black & Veatch employed EPRI’s ESVT software. ESVT is a dispatch modeling tool that can handle multiple energy storage applications at once. For the PV-sited storage facilities, the following energy storage applications were considered:

- Frequency Regulation
- Electric Supply Capacity
- Electric Energy Time-Shift
- Spinning Reserves
- Non-Spinning Reserves
- Transmission Voltage Support
- Distribution Voltage Support (PV Ramp)

ESVT dispatches energy storage systems in the analysis according to a hierarchy of applications. The hierarchy shown below is essentially the order in which the applications will get

selected and therefore dispatched. ESVT’s dispatch hierarchy is shown in Figure 2-11. For this project, longer term commitments such as T&D investment deferral and reliability applications are dispatched first, or top priority. Secondary priority goes to fulfilling system capacity. Lastly, ancillary services and energy markets are co-optimized to maximize revenue.

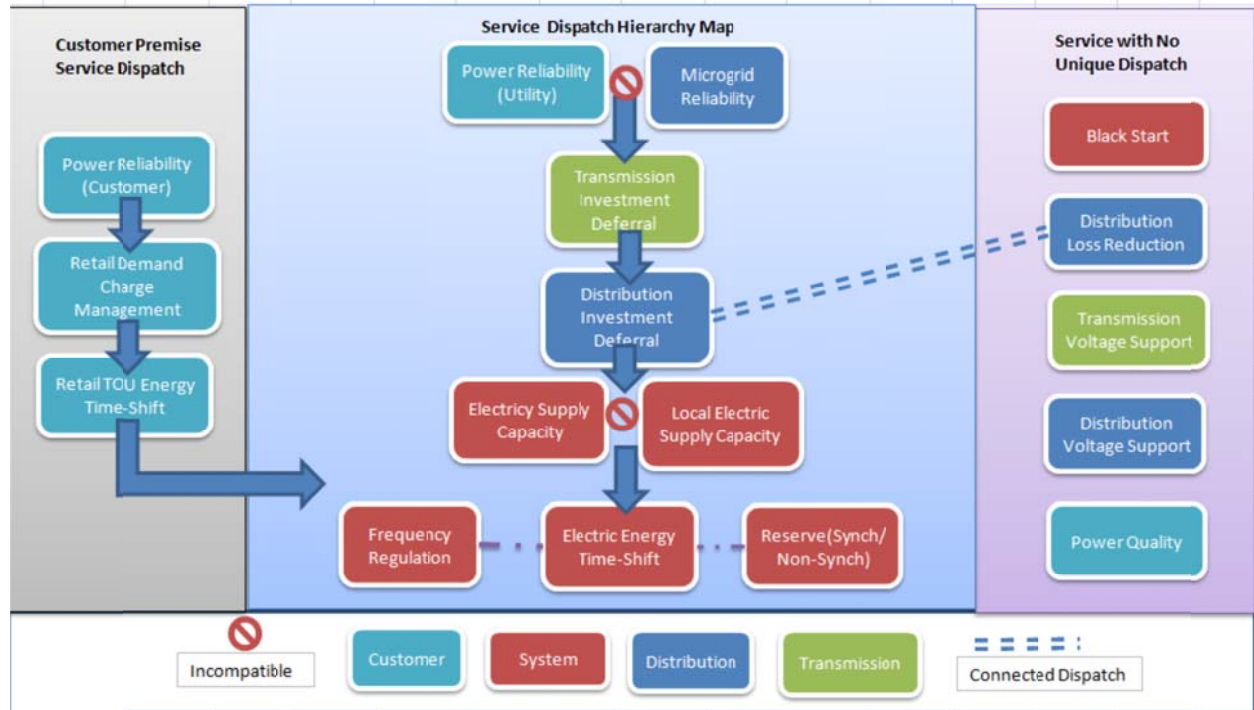

Figure 2-11 ESVT’s Dispatch Hierarchy

The detailed inputs for this analysis are included in Appendix B or have been provided to LADWP separately. A summary of the key assumptions and inputs are shown in Table 2-7.

Table 2-7 Key Input Assumptions

INPUT	ASSUMPTION
Frequency Regulation	
Regulation Price	LADWP Off-Peak Schedule 3 Frequency Regulation Rate (\$13.24/ MW, hourly)
Market Type	Combined Regulation Up and Down
Allow Load	Yes
Electric Supply Capacity	
Load Data	LADWP System Load Data
Capacity Value	LADWP Provided \$87/ kW-year
Electric Energy Time-Shift	

Energy Price	LADWP Hourly Energy Prices
Spinning Reserves	
Price Data	LADWP Off-Peak Schedule 5 Spinning Reserve Rate (\$10.74/ MW, hourly)
Non-Spinning Reserves	
Price Data	LADWP Off-Peak Schedule 6 Supplemental Reserve Rate (\$1.18/ MW, hourly)
Transmission Voltage Support	
Voltage Support Value	\$5/ kVAR-year
Distribution Voltage Support (PV Ramp)	
Capacity Reserved	Yes
Economic and Financial Inputs	
Percent Debt	100 %
Debt Rate	4 %
Inflation Rate	1 %

All inputs were obtained from LADWP through a detailed data request process. This process involved discussions on what inputs are best used in this analysis and justification for those inputs.

For frequency regulation, it was determined that the value a storage system can capture for providing this service within LADWP’s system is best represented by the avoided cost of providing this regulation. The cost associated with providing this frequency regulation service is included under Schedule 3 Open Access Transmission Tariff (OATT). ESVT takes as an input the data set that includes a value for 8760 hours of the year. The value that Black & Veatch used for this dataset throughout the year is the off-peak hourly rate according to Schedule 3 of LADWP’s OATT.

The off peak rate was selected as a conservative estimate. It is understood by Black & Veatch that the off-peak rate for this service is based on the cost of providing regulation within LADWP’s system. Therefore, if a storage system were to provide this resource, it is assumed that this is the avoided cost of providing this service by other means now or in the future with increased renewables (and more regulation requirements). It should be noted that if it was assumed that the storage system could off-set the on-peak cost of providing this regulation, the value the storage system could provide to the system via ESVT dispatch analysis would increase.

Black & Veatch also assumed that a combined market selection in ESVT is reasonable based on internal discussions and feedback from subcontractor E3. The combined market is a selection made in ESVT that can be selected instead of selecting a separate regulation up and regulation down market. The combined market approach for frequency regulation assumes that regulation is

not based on separate regulation up and regulation down markets, but is instead based on one value (described above). It is believed that the value provided by LADWP best fits this type of market and input to ESVT, and that a separate market for regulation up and regulation down should not be selected.

The AGC signal selected for the inter-hourly dispatch (which does not affect the value for regulation) was the CAISO AGC signal from 2010. Modifying the AGC signal is not allowed in ESVT, so this proxy was selected. The ability to allow load (or charging) for regulation was also selected in ESVT to take advantage of this unique resource.

For the system capacity application, system load data for all hours of the year was obtained from LADWP. Additionally, the assumed capacity value was confirmed with LADWP at \$87/ kW-year. This is roughly the cost of a combustion turbine and is the same assumption used in previous studies with Black & Veatch.

For electrical energy time-shift and the price of energy exchanges, Black & Veatch used 8760 price data provided by LADWP. This is believed to be a good representation of the cost of energy charged from the LADWP system as well as value of energy discharged back to the grid in any given hour of the year.

For spinning and non-spinning reserves, Black & Veatch used off-peak hourly rates according to LADWP’s OATT. For the voltage support service, Black & Veatch assumed \$5/ kVAR-year for a voltage support value for an input to ESVT. This is reflected as the cost for LADWP to provide voltage support under LADWP’s OATT and is in line with Black & Veatch’s expectations.

Finally, Black & Veatch used the distribution voltage ramping support application within ESVT to account for the amount of ramping support required for PV ramping analyzed in previous sections. Black & Veatch used the BESS output calculated from ramp rate control analysis in SmartES to estimate the amount of power (kW) that should be reserved for ramping support (ramp rate control). This power output was input as the power reservation in ESVT for ramping support. This was done to provide continuity between SmartES analysis and ESVT analysis, but does not significantly affect the results.

For each of the projects considered in this report, the storage system size used for economic analysis is based on the ramp rate control sizing discussed in previous sections. A summary of the economic findings is found in Table 2-8.

Table 2-8 Economic Analysis Results

	BEACON SOLAR	COPPER MOUNTAIN	Q09
Cost, \$M	70.8	50.5	40.4
Benefit, \$M	76.6	54.5	43.0
Benefit-to-Cost Ratio	1.083	1.080	1.063
IRR, %	8.5	8.1	6.0

The next three sections outline the more detailed economics of each individual project.

2.7.4 Beacon Solar Analysis

Beacon Solar is scheduled to come online in 2016 and was assumed to have a rated capacity of 350 MW. In discussions with LADWP, this rating may increase to 500 or 600 MW. Beacon Solar is near the Pine Tree Solar and Pine Tree Wind facilities and connects to the 230 kV switching station at Barren Ridge. Beacon Solar was analyzed with a 35 MW, 30 minute lithium ion BESS. The resulting NPV costs and benefits are shown in Figure 2-12. A detailed breakdown of the corresponding economics for each application and the costs of the storage system are shown in Table 2-9.

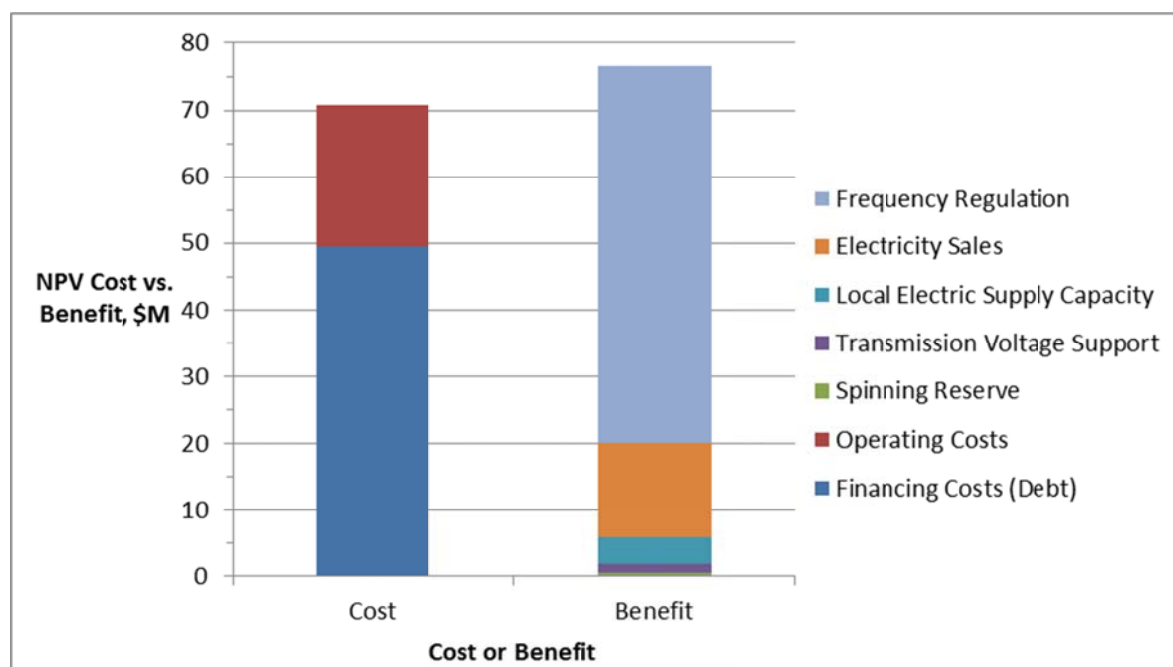

Figure 2-12 Beacon Solar NPV Costs and Benefits

Table 2-9 Beacon Solar ESVT Results Summary

BEACON SOLAR	COST, \$	BENEFIT, \$
Financing Costs (Debt)	49,417,083	0
Operating Costs	21,344,273	0
Taxes (Refund or Paid)	0	0
Investment Tax Credit	0	0
Capital Expenditure (Equity)	0	0
Non-synchronous Reserve (Non-spin)	0	0

Distribution Voltage Support (PV Ramp)	0	0
Synchronous Reserve (Spin)	0	490,015
Transmission Voltage Support	0	1,293,493
Local Electric Supply Capacity	0	4,165,041
Electricity Sales	0	14,127,038
Frequency Regulation	0	56,559,191
Total	70,761,356	76,634,779

The results indicate that the 35 MW storage facility at Beacon Solar will have benefit to cost ratio slightly greater than one over the lifetime of the project. The 1.08 benefit-to-cost ratio is in line with Black & Veatch’s expectations for this technology and application. This benefit-to-cost ratio is also in line with cost-effectiveness analysis performed by the Electric Power Research Institute (EPRI) for the California Public Utilities Commission (CPUC).⁵ The benefit-to-cost ratio for various scenarios ran for this CPUC analysis is shown in Figure 2-13. The reader can see that a benefit-to-cost ratio of 1.08 aligns with the lower end of the benefit-to-cost ratios found in this analysis. The bulk energy storage scenarios ran for CPUC analysis are similar to the scenarios Black & Veatch has performed for this analysis. The CPUC analysis reference here prioritized the scenarios they ran based on value expected for applications such as bulk energy storage (bulk energy storage scenarios shown below generally include system capacity, energy sales, frequency regulation, spinning reserves, etc), ancillary services case only (A/S shown below) as well as distributed storage sited at substations.

⁵ Electric Power Research Institute, “Cost-Effectiveness of Energy Storage in California.” June 2013.

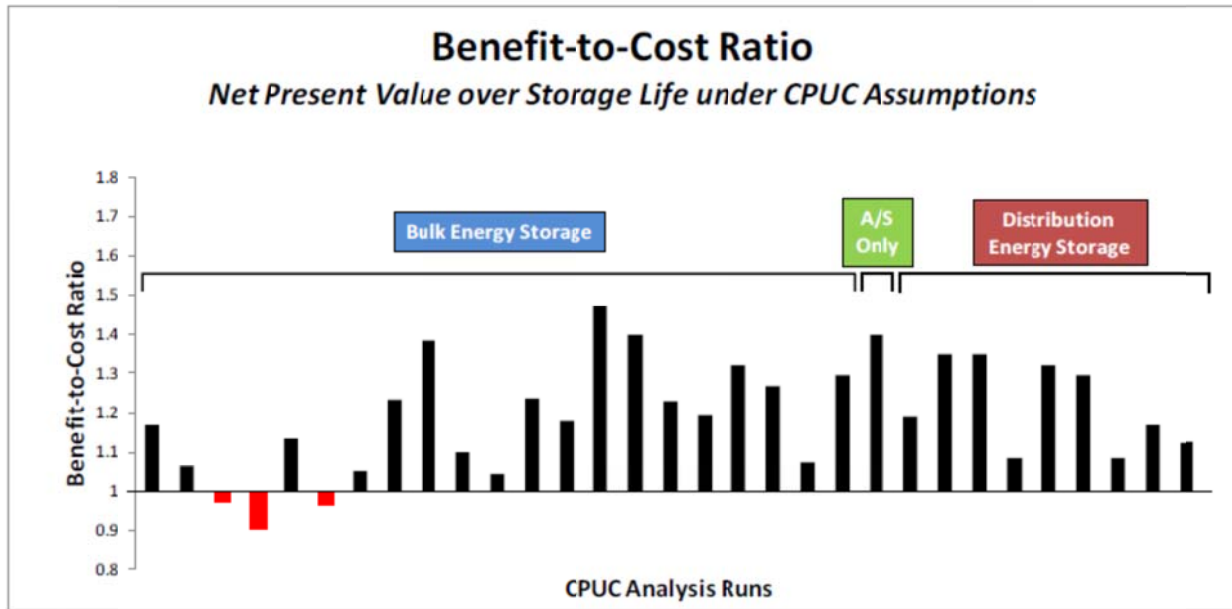

Figure 2-13 Benefit-to-Cost Ratio for Various Scenarios of CPUC Cost-Effectiveness Analysis

From the analysis performed by Black & Veatch, it can be seen that most of the value for storage systems is derived from frequency regulation. This is in agreement with the EPRI cost-effectiveness analysis in that often a significant portion of the value a storage system can provide is derived from frequency regulation. Therefore, it is essential that the BESS can be used most of the year for this application as is shown in the dispatch model within ESVT. In discussions with LADWP, this may be a reasonable assumption, as their current regulation resource mix is in the 40 to 50 MW range and is expected to increase as more renewables come online in the future.

Furthermore, Black & Veatch reviewed the 2010 renewable integration study where Black & Veatch estimated the level of regulation reserves required to integrate various levels of variable wind energy into LADWP’s system. According to this study, the 2015 need for 40 MW of regulation reserves (20 MW Regulation Up and 20 MW Regulation Down) is in line with the amount of regulation reserves currently on the LADWP system. The study indicated that LADWP will need 60 MW Regulation Up and 60 MW Regulation Down, or 120 MW total, in 2020. The proposed energy storage size of 35 MW fits within this anticipated need of an additional 40 MW by 2020. Since most of the value for this energy storage resource is derived from regulation, it is critical to ensure that the resource will be needed and used for frequency regulation. Therefore, it is recommended that the regulation requirements be updated given added regulation resources and changes in expected renewable energy installations since Black & Veatch studied regulation requirements for LADWP in 2010. It should be noted that if regulation is removed from the ESVT model, the dispatch picks up other services in its place such as spinning reserves. This results in similar economics since the storage system is freed up to perform other services included. However, if regulation and spinning/non-spinning reserves are all removed, the storage system is not cost effective. This

further solidifies the importance of being able to operate the storage system for many applications throughout the year.

The energy storage system is effective in performing this application (regulation) due to its rapid and accurate response times to regulation signals. It has been shown in other areas where energy storage is providing this service that the presence of these systems and market changes that go along with them may actually reduce the regulation requirements on the system. Additionally, it is reasonable to assume that this resource could replace existing regulation resources and free these assets up for other services.

2.7.5 Copper Mountain Analysis

Copper Mountain is currently coming online and will have a rated capacity of 250 MW. Copper Mountain connects to a switching station on the Crystal – McCullough 500 kV line. Copper Mountain was analyzed with a 25 MW, 30 minute lithium ion BESS. The resulting NPV costs and benefits are shown in Figure 2-14. A detailed breakdown of the corresponding economics for each application and the costs of the storage system are shown in Table 2-10.

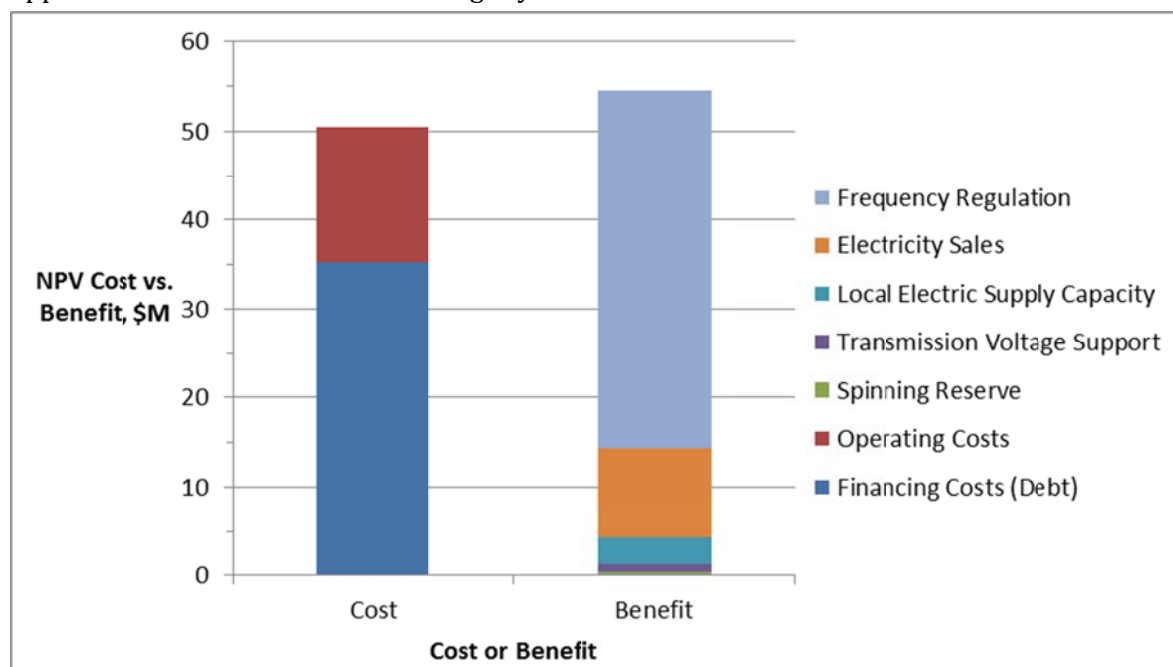

Figure 2-14 Copper Mountain NPV Costs and Benefits

Table 2-10 Copper Mountain ESVT Results Summary

COPPER MOUNTAIN SOLAR	COST, \$	BENEFIT, \$
Financing Costs (Debt)	35,297,916	0
Operating Costs	15,180,339	0
Taxes (Refund or Paid)	0	0

Investment Tax Credit	0	0
Capital Expenditure (Equity)	0	0
Non-synchronous Reserve (Non-spin)	0	0
Distribution Voltage Support (PV Ramp)	0	0
Synchronous Reserve (Spin)	0	342,154
Transmission Voltage Support	0	923,923
Local Electric Supply Capacity	0	3,023,123
Electricity Sales	0	10,038,326
Frequency Regulation	0	40,181,653
Total	50,478,256	54,509,180

As with the Beacon Solar BESS previously discussed, the benefit-to-cost ratio is about 1.08 and is in line with the lower end of the California cost-effectiveness analysis. The reason for this similarity is because ESVT can only model system wide inputs for prices and load which are the same for both projects. As mentioned in the introduction, the analysis did not look at local grid specific stability issues which could provide additional benefits for storage at each location. Additionally, the same cost assumptions for the storage system were assumed since the scale of these two systems is similar.

2.7.6 Q09 Solar Project Analysis

Q09 Solar Project is scheduled to come online in 2018 and will have a rated capacity of 200 MW. Q09 connects to a switching station on the Inyo – Cottonwood 230 kV line. Q09 was analyzed with a 20 MW, 30 minute lithium ion BESS. The resulting NPV costs and benefits are shown in Figure 2-15. A detailed breakdown of the corresponding economics for each application and the costs of the storage system are shown in Table 2-11.

The difference in economics between Q09 and the Beacon Solar and Copper Mountain battery storage systems is that Q09 analysis did not include the service of transmission voltage support. This is because a Static Var Compensator (SVC) is budgeted and scheduled to be included with Q09 to mitigate voltage issues that may occur at this site.⁶ The storage system could provide this support if this option were selected, but this option was not included in this analysis since the SVC has already been approved. Since most of the value is derived from regulation as with the other use cases and there may be a limited number of regulation resources required, other BESS locations may be recommended over a BESS at Q09. However, this option and size can be reassessed to meet the 2021 implementation requirement if needed.

⁶ According to the 2013 Long-Term Transmission Assessment

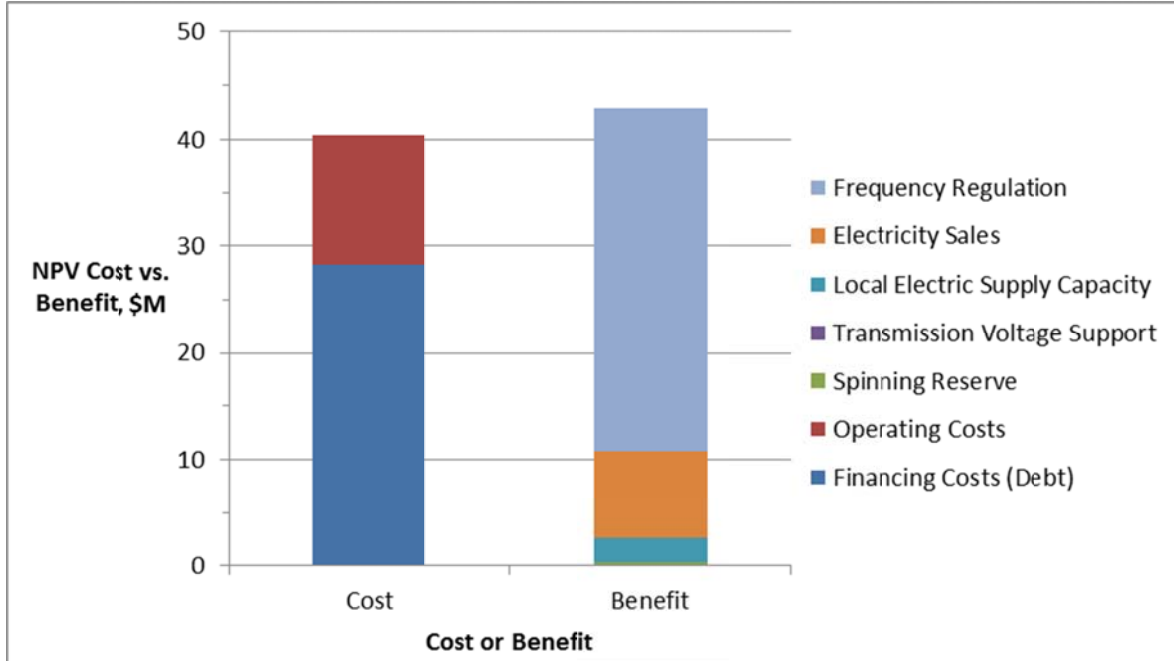

Figure 2-15 Q09 NPV Costs and Benefits

Table 2-11 Q09 ESVT Results Summary

Q09	COST, \$	BENEFIT, \$
Financing Costs (Debt)	28,238,333	0
Operating Costs	12,171,964	0
Taxes (Refund or Paid)	0	0
Investment Tax Credit	0	0
Capital Expenditure (Equity)	0	0
Non-synchronous Reserve (Non-spin)	0	0
Distribution Voltage Support (PV Ramp)	0	0
Synchronous Reserve (Spin)	0	286,515
Local Electric Supply Capacity	0	2,380,118
Electricity Sales	0	8,053,812
Frequency Regulation	0	32,245,815
Total	40,410,297	42,966,260

2.7.7 High Level Comparison with Alternatives

In order to properly determine if a storage unit is cost-effective, the cost of alternatives to provide the same services must be considered. Although this is outside the scope of this study, Black & Veatch looked at a high level comparison to a combustion turbine providing similar services throughout the year.

Based on previous work performed by Black & Veatch for LADWP on integration cost for solar and wind, the carrying cost of an LMS100 gas turbine is \$87/kW-yr and the operating cost, taking into account both upward regulation and fixed O&M, is \$55.30/MWh. The storage system is expected to dispatch (output) between approximately 1,000 MWh and 6,000 MWh of energy over the course of the year according to ESVT dispatch and Black & Veatch estimates. Converting this to a levelized \$/ kW-yr value with this expected dispatch and adding this to a typical fixed O&M cost of \$18/ kW-yr results in the following estimates. The levelized costs for each of the BESS facilities according to ESVT are also presented below.

Table 2-12 Energy Storage and Combustion Turbine Cost Comparison

	BEACON SOLAR	COPPER MOUNTAIN	Q09	LMS100 GAS TURBINE
Financing Costs (Debt), \$/ kW-yr	94.13	94.13	94.13	87.00 – 150.00
Operating Costs, \$/ kW-yr	40.66	40.48	40.57	20 – 30

Assuming both systems can operate in a similar fashion and provide the services under consideration, the benefits that the BESS and the gas turbine can capture are expected to be similar. The results indicate that the storage systems under consideration may be a viable option to provide the services studied. However, more thorough comparisons of the detailed costs of a combustion turbine (and/or other resources) providing these services are recommended. More detailed comparisons could consider responsiveness, more detailed operations cost and greenhouse gas emissions.

2.8 ENERGY STORAGE VENDORS

Black & Veatch maintains a database of almost 100 technology vendors in the energy storage industry. Of these, Black & Veatch maintains working relationships with the top tier providers. Black & Veatch works with the lithium ion solution suppliers listed in Table 2-13 below. These suppliers can each provide a complete battery energy storage system of the sizes discussed in this report including:

- Battery Modules
- Power Conversion System (PCS)
- Battery Management System
- BESS/ Site Controller

- HVAC
- Fire Suppression
- Container

An EPC firm such as Black & Veatch would therefore offer a complete solution including the balance of plant and interconnection. Below is a list of lithium ion providers that we expect can meet the requirements of the applications studied in this report.

Table 2-13 Energy Storage Vendor List

VENDOR LIST	
Altairnano	Mitsubishi
BYD	NEC
Electrovaya	Panasonic
EnerDel	Saft
GS Yuasa	Samsung SDI
Hitachi	Tesla Motors
LG Chem	Toshiba

2.9 RECOMMENDATIONS

Black & Veatch recognizes the requirement for LADWP to define transmission level energy storage targets to be implemented by the 2016 and 2021 timeframes. We believe that the three solar farm projects studied are viable for a BESS. However, for LADWP to make final determination of economically viable energy storage targets, we offer the following recommendations:

- Black & Veatch recommends doing a more detailed analysis comparing the costs of alternative methods of providing all of the services under consideration to the LADWP system. This would include updated capital and operating costs and weighing factors such as response times and emissions impacts.
- It is recommended that LADWP perform an interconnection study at facilities that will be considered further for the 2016 and 2021 targets. This should involve an investigation on other system issues in the area under consideration and how storage could potentially help mitigate these issues.
- Finally, it is recommended that LADWP update their frequency regulation requirements due to increased solar PV generation coming onto the LADWP system. This should explore the amount of regulation resource requirements as well as incorporate the impact of fast responding energy storage systems in addition to traditional regulation assets. This will indicate when the energy storage system may be required for regulation reserves and therefore when the energy storage system can capture the majority of the benefits from providing frequency regulation.

3.0 Battery Energy Storage at Olympic Receiving Station

Black & Veatch was tasked with assessing the feasibility of a battery energy storage system at Olympic Receiving Station that will be used to reduce the amount of load shedding in the event of contingencies highlighted in LADWP's 2013 Long-Term Transmission Plan. This load shedding is required to maintain compliance with NERC TPL standards. This section of the report outlines the information that was reviewed by Black & Veatch and the resulting recommendations.

3.1 INFORMATION AND DATA REVIEWED

Black & Veatch reviewed the 2013 Long-Term Transmission Plan as well as the PSLF models provided by LADWP. Black & Veatch reviewed the following contingencies relating to the Olympic Receiving Station:

During a heat storm in 2014 and until the limitation is addressed:

- A simultaneous (N-2) outage of Tarzana-Olympic 230kV Line 3 and Tarzana-Olympic 138kV Line 1 would overload Scattergood-Olympic 230kV Circuit 2.

During a heat storm in 2015 and until the limitation is addressed:

- A ((N-1)-1) outage of the Tarzana-Olympic 138kV Line followed by the loss of 230/138kV Transformer Bank E or Bank F at Olympic Station would overload the other remaining transformer.

As a result of the above contingencies, the following actions are currently being taken, and are taken into account:

To mitigate the summer 2014 issues:

- Long-term, install new Scattergood-Olympic 230kV Cable A to relieve the loading on Scattergood-Olympic Circuit 2 during a simultaneous outage of Tarzana-Olympic 230kV Line 1 and Tarzana-Olympic 138kV Line 1. Until this work is completed in 2015, the selective load-shedding program at Olympic Station to respond to this double contingency must continue to be available.

To mitigate the summer 2015 issues:

- Long-term, either move one Load Bank at Olympic Station to the 230kV (high) side or install a new Bus Bank at the station to mitigate a transformer overload from the (N-1)-1 outage of the Tarzana-Olympic 138kV Line 1 followed by the loss of 230/138kV Transformer Bank E or Bank F at Olympic Station. Short-term, a selective load-shedding program at Olympic Station must be devised and available prior to Summer 2015.

Upon review, the load shedding occurs as a result of thermal overloads (i.e. steady-state conditions) not a transient instability. Since no transient issues originally existed, Black & Veatch does not expect transient issues to arise with the addition of a battery energy storage system.

The amount of load shedding due to the N-2 contingency is about 100 MW. The amount of load shedding due to the (N-1)-1 contingency and resulting transformer overload is about 162 MW. To avoid this load shedding amount, a battery was being considered by LADWP. However, Scattergood-Olympic 230kV Cable A is already in the construction phase and therefore this upgrade cost could not be deferred. Additionally, the new high-side 230/34.5 kV transformer bank that has

been recommended by transmission planners would be more economically viable than implementing a storage system to defer this upgrade. Finally, LADWP suggests the expected frequency of this contingency is 5-10 years. As a result, a battery storage system at this location is not economically justifiable. This battery storage system would be too large for space constraints in this area as well.

Black & Veatch investigated with LADWP if a critical load exists that cannot be shed to further explore a storage system at this location. However, the critical load was found to be minimal or non-existent.

Additionally, an energy-based storage system serving only capacity contribution, now that avoiding load shedding in the event of a contingency is not viable, is also not economically feasible. In other words, since peak shifting will not improve the economics in this case, capacity contribution only was not considered for reasons discussed earlier in this report.

Black & Veatch explored example scenarios with the Olympic Receiving Station load data that LADWP provided. SmartES was used to size an energy storage system to reduce the peak load on the system with a flow battery. However, this was used only to demonstrate how this analysis might look and how the peak shaving application within SmartES is used to defer expensive capital investments. A flow battery is not necessarily recommended, but for energy applications such as this, a flow battery would be considered along with other energy-based storage technologies.

In this case, the transformer upgrade defined in the Transmission Plan is considered to be a more economically viable option. An example screenshot of this analysis performed in SmartES at Olympic Receiving Station is shown in Figure 3-1.

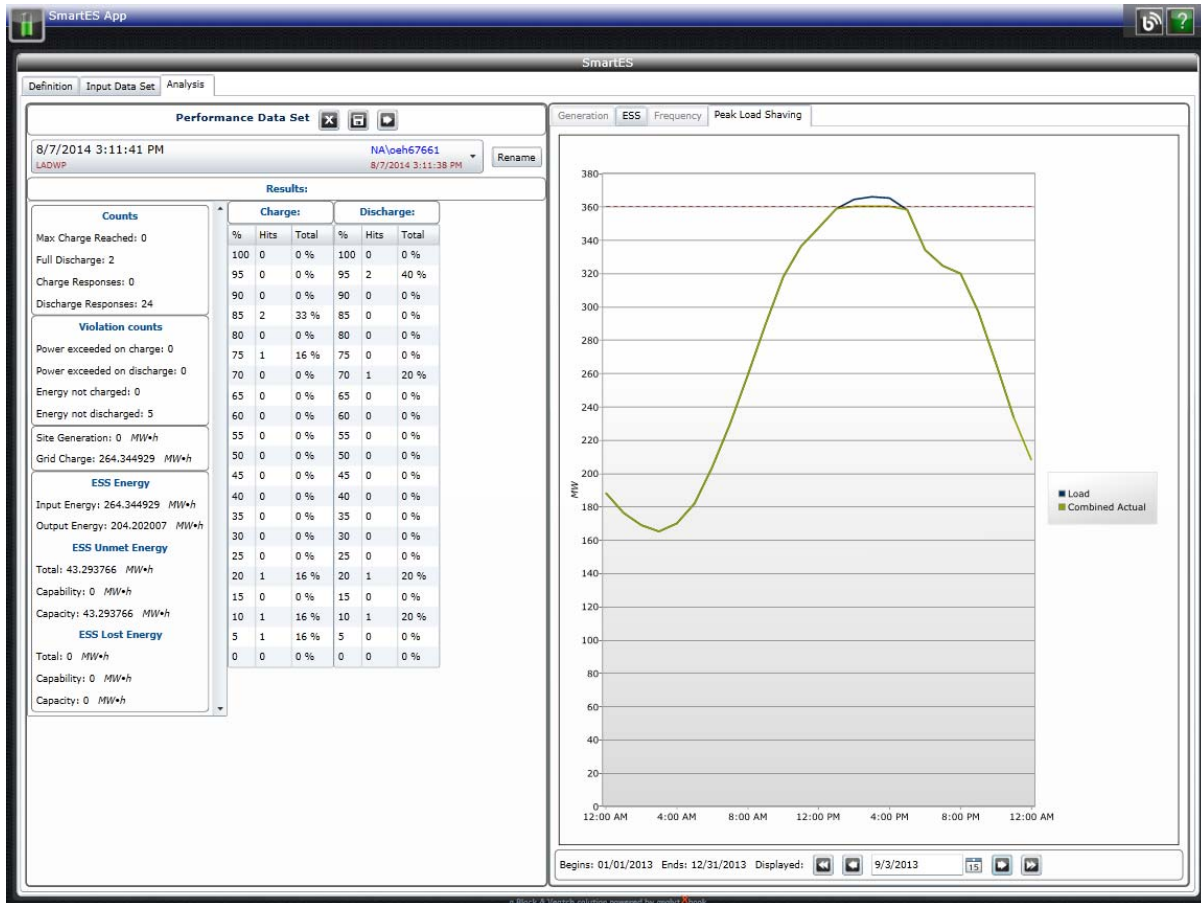

Figure 3-1 SmartES Screenshot of Peak Shaving Analysis at Olympic Receiving Station

The SmartES example analysis was done with the RS-K Olympic Receiving Station load data provided by LADWP. It should be noted that no overloads occur under normal operation. However, the SmartES analysis showed that to reduce peak load at the Olympic Receiving Station by approximately 20 MW, or reducing the peak load from around 379 MW to 360 MW in this example, approximately a four to six hour energy storage system is required. Since this peak shaving application is more of an energy application that requires longer periods of discharge, a flow battery was used within SmartES for this analysis. Flow batteries are better suited for durations in the four to six hour range.

3.2 RECOMMENDATIONS

Black & Veatch does not recommend a battery storage system at the Olympic Receiving Station. Planned upgrades as well as more cost-effective alternatives that are in progress are recommended for this project.

Appendix A. SmartES Model References

MODEL OR FILE NAME	DESCRIPTION	PV DATASET	BESS
Pine Tree RRC 10% B10 6/30/2014 9:28:08 AM	Ramp Rate Control Limit 10%, Battery at 10% of PV Capacity	Pine Tree Solar 9 MW – 2013_2014 Minute NoFeb13	LADWP BESS PTS 9 – 10 % 2C
Pine Tree RRC 10% B20 6/30/2014 9:44:49 AM	Ramp Rate Control Limit 10%, Battery at 20% of PV Capacity	Pine Tree Solar 9 MW – 2013_2014 Minute NoFeb13	LADWP BESS PTS 9 – 20 % 2C
Pine Tree RRC 15% B10 6/30/2014 9:39:50 AM	Ramp Rate Control Limit 15%, Battery at 10% of PV Capacity	Pine Tree Solar 9 MW – 2013_2014 Minute NoFeb13	LADWP BESS PTS 9 – 10 % 2C
Pine Tree RRC 15% B20 6/30/2014 9:55:04 AM	Ramp Rate Control Limit 15%, Battery at 20% of PV Capacity	Pine Tree Solar 9 MW – 2013_2014 Minute NoFeb13	LADWP BESS PTS 9 – 20 % 2C
Copper Mountain RRC 10% B10 6/19/2014 8:45:57 AM	Ramp Rate Control Limit 10%, Battery at 10% of PV Capacity	Copper Mountain 48 MW – FullData Minute	LADWP BESS CM 48 – 10% 2C Used
Copper Mountain RRC 10% B20 6/19/2014 9:14:25 AM	Ramp Rate Control Limit 10%, Battery at 20% of PV Capacity	Copper Mountain 48 MW – FullData Minute	LADWP BESS CM 48 – 20% 2C Used
Copper Mountain RRC 15% B10 6/19/2014 8:30:09 AM	Ramp Rate Control Limit 15%, Battery at 10% of PV Capacity	Copper Mountain 48 MW – FullData Minute	LADWP BESS CM 48 – 10% 2C Used
Copper Mountain RRC 15% B20 6/19/2014 9:07:06 AM	Ramp Rate Control Limit 15%, Battery at 20% of PV Capacity	Copper Mountain 48 MW – FullData Minute	LADWP BESS CM 48 – 20% 2C Used
Pine Tree FR B10	Frequency Regulation with 1% Droop, 0.1% Deadband, Battery at 10% of PV Capacity	Pine Tree Solar 9 MW – Frequency Combined	0.9 MW Li Ion BESS - 30 Minute
Copper Mountain FR B10	Frequency Regulation with 1% Droop, 0.1% Deadband, Battery at 10% of PV Capacity	Pine Tree Solar 9 MW – Frequency Combined	25 MW Li Ion BESS - 30 Minute
Beacon FR B10	Frequency Regulation with 1% Droop, 0.1% Deadband, Battery at 10% of PV Capacity	Pine Tree Solar 9 MW – Frequency Combined	35 MW Li Ion BESS - 30 Minute
Q09 FR B10	Frequency Regulation with 1% Droop, 0.1% Deadband, Battery at 10% of PV Capacity	Pine Tree Solar 9 MW – Frequency Combined	20 MW Li Ion BESS - 30 Minute

Appendix B. ESVT Model References

MODEL OR FILE NAME	DESCRIPTION
Task 3 – Q09 20 MW - 30 min Li ion Final Model.ana	Q09 ESVT Model BESS
Task 3 - Copper Mountain 25 MW - 30 min Final Model.ana	Copper Mountain ESVT Model BESS
Task 3 - Beacon Solar 35 MW - 30 min Li ion Final Model.ana	Beacon Solar ESVT Model BESS

Appendix C. PSLF Model References

MODEL OR FILE NAME	DESCRIPTION
2013typ-hs18-499pdci-3795vicla_Beacon600_SOVSR200.sav	PSLF Power Flow Case - Increased Beacon and Q09 capacity.
13hs-TYTA-dwp-v4_Beacon600_SOVSR200.dyd	Modified PSLF dynamics file.
ramp.p	EPCL program to simulate cloud cover at Beacon and Q09 by controlling the “pv1e” PV controller real power reference.

Appendix 5

Energy Storage Distribution Impact and Value Analysis by EPRI

This space is intentionally left blank

Energy Storage Distribution Impact and Valuation Analysis for the Los Angeles Department of Water and Power (LADWP)

Executive Summary

September 2014

DISCLAIMER OF WARRANTIES AND LIMITATION OF LIABILITIES

THIS DOCUMENT WAS PREPARED BY THE ORGANIZATION(S) NAMED BELOW AS AN ACCOUNT OF WORK SPONSORED OR COSPONSORED BY THE ELECTRIC POWER RESEARCH INSTITUTE, INC. (EPRI). NEITHER EPRI, ANY MEMBER OF EPRI, ANY COSPONSOR, THE ORGANIZATION(S) BELOW, NOR ANY PERSON ACTING ON BEHALF OF ANY OF THEM:

(A) MAKES ANY WARRANTY OR REPRESENTATION WHATSOEVER, EXPRESS OR IMPLIED, (I) WITH RESPECT TO THE USE OF ANY INFORMATION, APPARATUS, METHOD, PROCESS, OR SIMILAR ITEM DISCLOSED IN THIS DOCUMENT, INCLUDING MERCHANTABILITY AND FITNESS FOR A PARTICULAR PURPOSE, OR (II) THAT SUCH USE DOES NOT INFRINGE ON OR INTERFERE WITH PRIVATELY OWNED RIGHTS, INCLUDING ANY PARTY'S INTELLECTUAL PROPERTY, OR (III) THAT THIS DOCUMENT IS SUITABLE TO ANY PARTICULAR USER'S CIRCUMSTANCE; OR

(B) ASSUMES RESPONSIBILITY FOR ANY DAMAGES OR OTHER LIABILITY WHATSOEVER (INCLUDING ANY CONSEQUENTIAL DAMAGES, EVEN IF EPRI OR ANY EPRI REPRESENTATIVE HAS BEEN ADVISED OF THE POSSIBILITY OF SUCH DAMAGES) RESULTING FROM YOUR SELECTION OR USE OF THIS DOCUMENT OR ANY INFORMATION, APPARATUS, METHOD, PROCESS, OR SIMILAR ITEM DISCLOSED IN THIS DOCUMENT.

REFERENCE HEREIN TO ANY SPECIFIC COMMERCIAL PRODUCT, PROCESS, OR SERVICE BY ITS TRADE NAME, TRADEMARK, MANUFACTURER, OR OTHERWISE, DOES NOT NECESSARILY CONSTITUTE OR IMPLY ITS ENDORSEMENT, RECOMMENDATION, OR FAVORING BY EPRI.

THE FOLLOWING ORGANIZATION(S), UNDER CONTRACT TO EPRI, PREPARED THIS REPORT:

Electric Power Research Institute (EPRI)

This is an EPRI Technical Update report. A Technical Update report is intended as an informal report of continuing research, a meeting, or a topical study. It is not a final EPRI technical report.

NOTE

For further information about EPRI, call the EPRI Customer Assistance Center at 800.313.3774 or e-mail askepri@epri.com.

Electric Power Research Institute, EPRI, and TOGETHER...SHAPING THE FUTURE OF ELECTRICITY are registered service marks of the Electric Power Research Institute, Inc.

Copyright © 2014 Electric Power Research Institute, Inc. All rights reserved.

ACKNOWLEDGMENTS

The following organizations prepared this report:

Electric Power Research Institute
3420 Hillview Ave.
Palo Alto, CA 94304-1395

Principal Investigators:

A. Maitra
S. Chen
H. Kamath

University of Texas at Austin

Principal Investigators:

S. Santoso

EPRI gratefully acknowledges the extensive assistance provided by LADWP in the production of this report.

This report describes research sponsored by EPRI.

This publication is a corporate document that should be cited in the literature in the following manner:

CONTENTS

1 EXECUTIVE SUMMARY	1-1
Objective and Methodology	1-1
PV Hosting Capacity	1-4
Energy Storage Cost Projection	1-4
Energy Storage Analysis Approaches	1-5
System-Level Analysis	1-6
Customer Level Benefits	1-13
Conclusion	1-17

1

EXECUTIVE SUMMARY

Objective and Methodology

Energy storage technology is an important potential option for utilities, system operators, and end users to increase reliability and reduce the cost of electricity. It may be especially important as a flexibility asset to address the integration of variable generation resources such as wind and solar. Storage may also be a tool to improve asset utilization at the distribution level, and if it can be produced at a very low cost, it can be used for diurnal energy arbitrage

However, the widespread use of energy storage is unlikely without additional development of the technology and examples of its successful application. Costs for storage have been falling, thanks, in part, to heavy technology investment from the consumer electronics sector and now the automotive sector in support of electric vehicles. In addition, product vendors are increasingly stepping forward to create complete energy storage systems from the underlying battery technology as of the present day. In the end, this effort would further the overall goal of the industry to have “plug-and-play” standardized storage products that utilities will know how to install with minimal special effort required.

On the utility side, widespread implantation of electricity storage is thought to be facilitated by establishment of well-understood practices for interconnection of storage to the grid, as well as appropriate control technologies that can enable multiple value streams to justify the capital and operations cost of storage. Before that can happen, practices will need to be developed that allow utilities to integrate storage with the same level of expertise and confidence as other conventional resources both at the system level and the distribution level.

Assembly Bill 2514 requires LADWP to determine the feasibility of energy storage (ES) within its system. If the technology is cost-effective and viable, then procurement targets must be presented to the CEC by October, 1 2014. This project will develop consistent methodology and data analytics necessary to evaluate various deployments scenarios of energy storage (*utility-connected as well as customer sited*) on one feeder selected by LADWP within its service territory.

The analysis was carried out on one of the 34.5KV feeders. Figure ES 1 compares the circuit loading of feeders within LADWP service territory. Although detailed feeder selection criteria and analysis was not conducted, the basis to select one feeder from the 34.5KV system included:

- Future load growth potential on feeder connected at the 34.5KV level is higher than feeders connected at 4.8KV
- Focus on commercial customers
- Existing PV generation along the feeder
- Availability of customer and substation loading data and electrical models

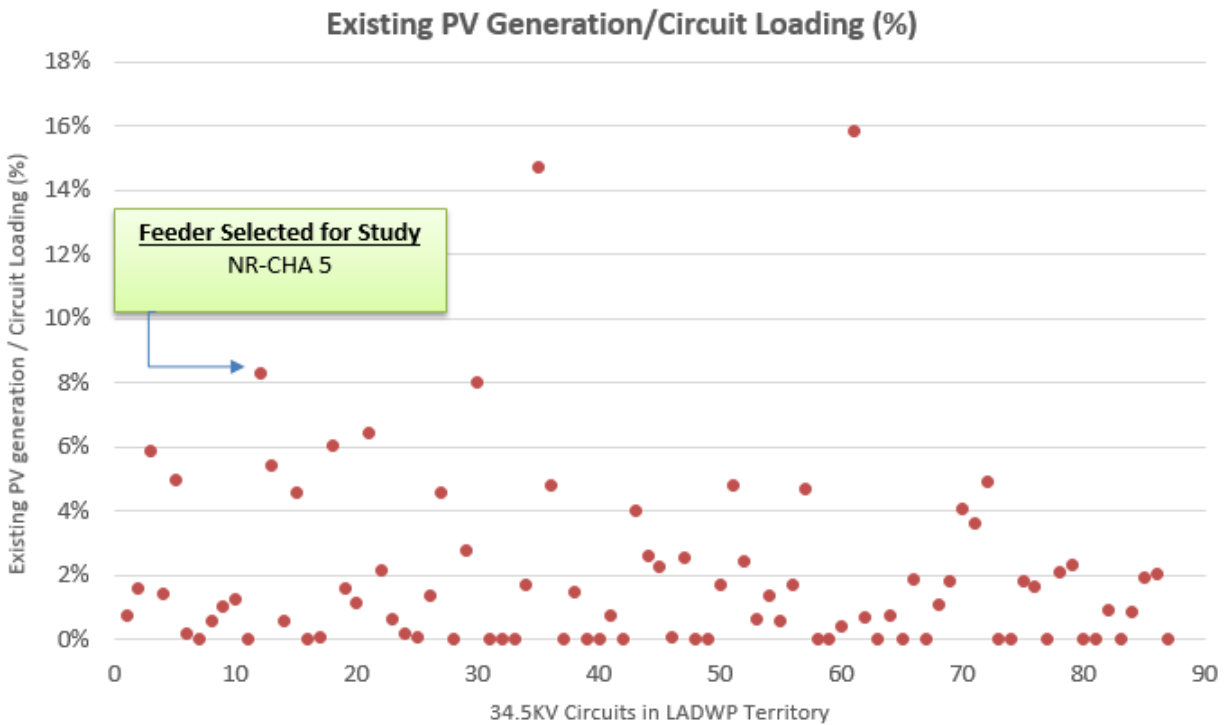
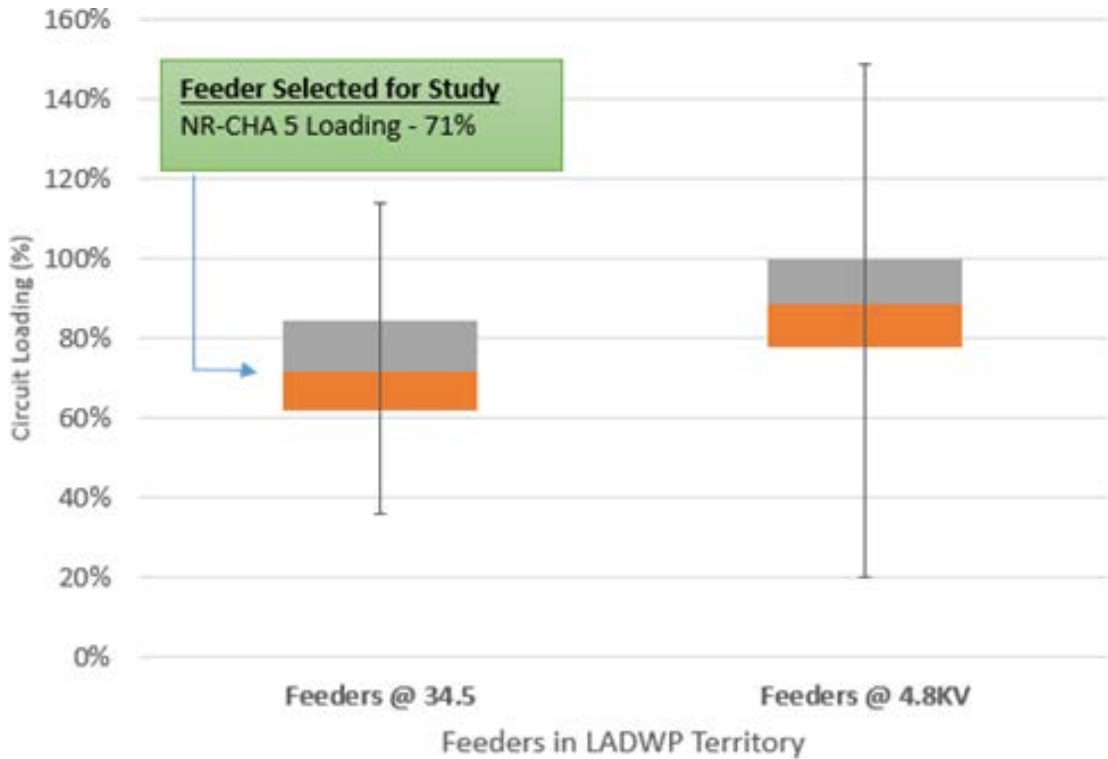

Figure ES 1: LADWP Feeder Loading Characteristics – A Comparison

The NR-CHA-5 feeder chosen for the analysis is supplied by RS-J Bank-D. RS-J Bank-D is a 160 MVA 230-kV/34.5-kV substation transformer supplying for eight distribution feeders (see Figure ES 2). The overall framework utilized is shown in Figure ES 3.

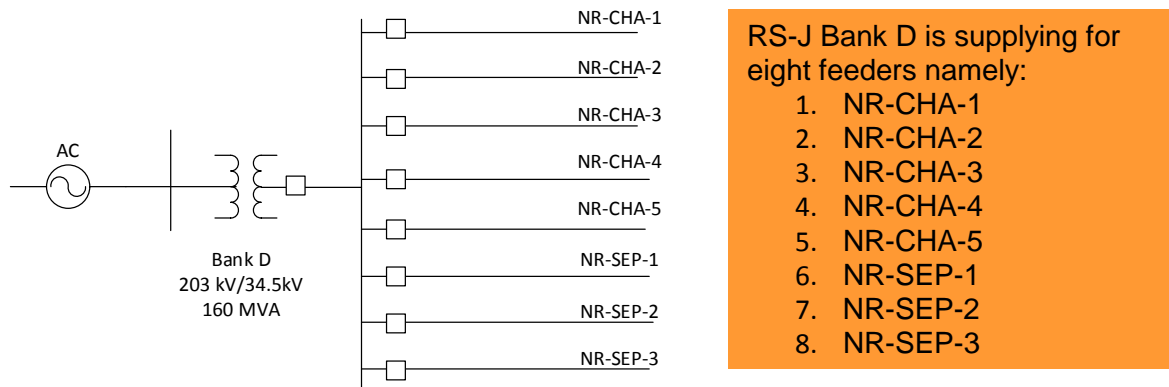

Figure ES 2: One line diagram - LADWP circuit supplied by RS-J Bank D

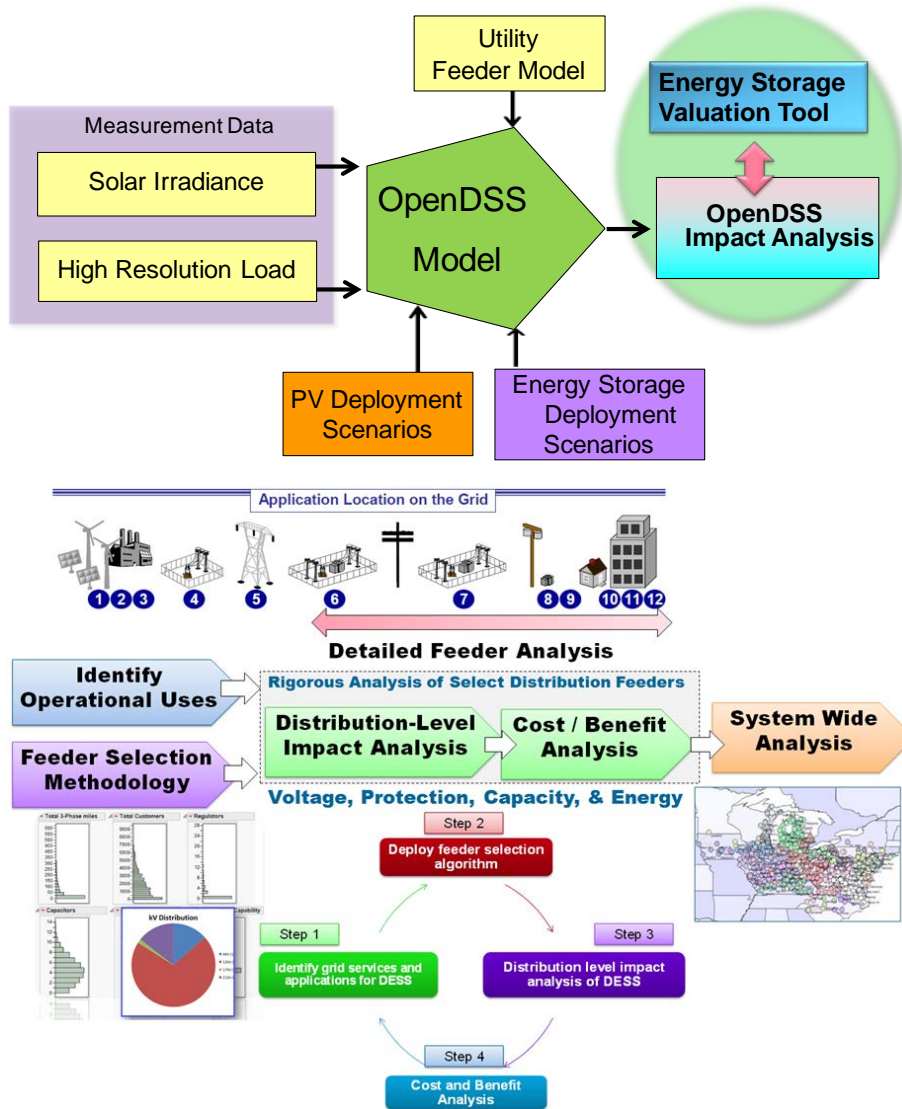

Figure ES 3: Impact Analysis Framework

PV Hosting Capacity

The energy storage assessment for a given distribution circuit will depend on the current distribution circuit conditions and projected distributed generation (DG) penetration and load growth. Based on current and future circuit requirements, a starting point for the energy storage analysis is identified. Integration of distributed energy resources such as distributed photovoltaic (PV) generation into the power grid can potentially lead to voltage regulation issues, necessitating infrastructure improvements and changes to circuit operation. Furthermore, high PV penetration can cause reverse power flow in the circuit which may lead to protection equipment malfunction and thus decrease system reliability. An energy storage unit can potentially mitigate both voltage and reverse power flow concerns. Therefore, the PV integration limits, referred to as the PV hosting capacity, for the selected feeder are first calculated. The objective of this initial analysis is to determine the maximum PV that can be accommodated in a given distribution circuit without violating circuit's critical operating conditions.

In this work, the PV hosting capacity is defined with respect to two circuit criteria: bus overvoltage and reverse power flow condition. For the overvoltage criteria, PV hosting capacity is defined as the maximum PV generation that can be accommodated without necessitating the action of any voltage regulating equipment such as voltage regulator and capacitors. For the purpose of this report, PV hosting capacity is reached when one or more primary bus voltages are 1.05 pu or higher. For the reverse power flow criteria, PV hosting capacity is equal to the minimum PV generation resulting in a reverse active power flow at the feeder head. Clearly, a reverse power flow condition will arise when the total PV generation exceeds the feeder's minimum load demand.

The PV hosting capacity for both criteria is calculated for the selected LADWP circuit. In order to identify the worst case condition, the PV hosting analysis is done when the circuit is operating at the minimum load condition. To identify the minimum load condition, the minimum load recorded during daylight hours for each day of Year 2013-2014 are analyzed. The actual sunrise and sunset hours are used to identify the load demand during daylight hours. The minimum load demands are recorded for each day and are plotted using a histogram plot. The median value of the histogram plot is considered as the representative minimum load condition for the circuit. Using the analysis, the minimum load obtained for NR-CHA 5 feeder is equal to 5.3 MW. The existing 1.53 MW PV generation is included in the analysis and additional PV generation is increased incrementally for the purpose of analysis. Since the future PV deployment scenario is unpredictable, both in terms of their location and size, stochastic analyses are simulated to obtain a representative estimate for PV hosting capacity. Based on this analysis for the NR-CHA-5 feeder, the following PV hosting capacities are obtained:

1. PV hosting for overvoltage criteria is 16.2 MW, including 14.6 MW additional PV and 1.53 MW of existing PV.
2. PV hosting for reverse power flow criteria is 5.3 MW, including 3.7 MW additional PV and 1.53 MW of existing PV.

Energy Storage Cost Projection

While there are many methods to store electric energy, only a few are practical for grid-scale energy storage at present. These include pumped hydro storage, compressed air energy storage (CAES), and large-scale batteries. Pumped-hydro and compressed air storage technologies are well-suited for very large energy storage applications, but are difficult to scale down to the smaller sizes needed at the distribution level, at least with present technology. While much research is going towards cost-effective options in smaller installation, at present we must turn to batteries as a more viable option for systems smaller than 10 MW in size.

A large number of battery technologies have been proposed in utility applications, ranging from relatively well-understood technologies such as lead-acid batteries to newer prospects such as metal-air and redox flow batteries. These latter technologies have been successfully deployed in several instances, and costs are rapidly declining, but they are still relatively immature and expensive. For the purposes of this study, we confine ourselves to cost calculations using lithium ion batteries, which are mature enough that reasonable predictions can be made about their life and performance characteristics, but which also are improving rapidly in terms of cost and performance and so are likely to remain viable as a highly attractive storage option for at least the next decade.

The lithium ion battery lifetime cost projections are provided in Figure ES 4.

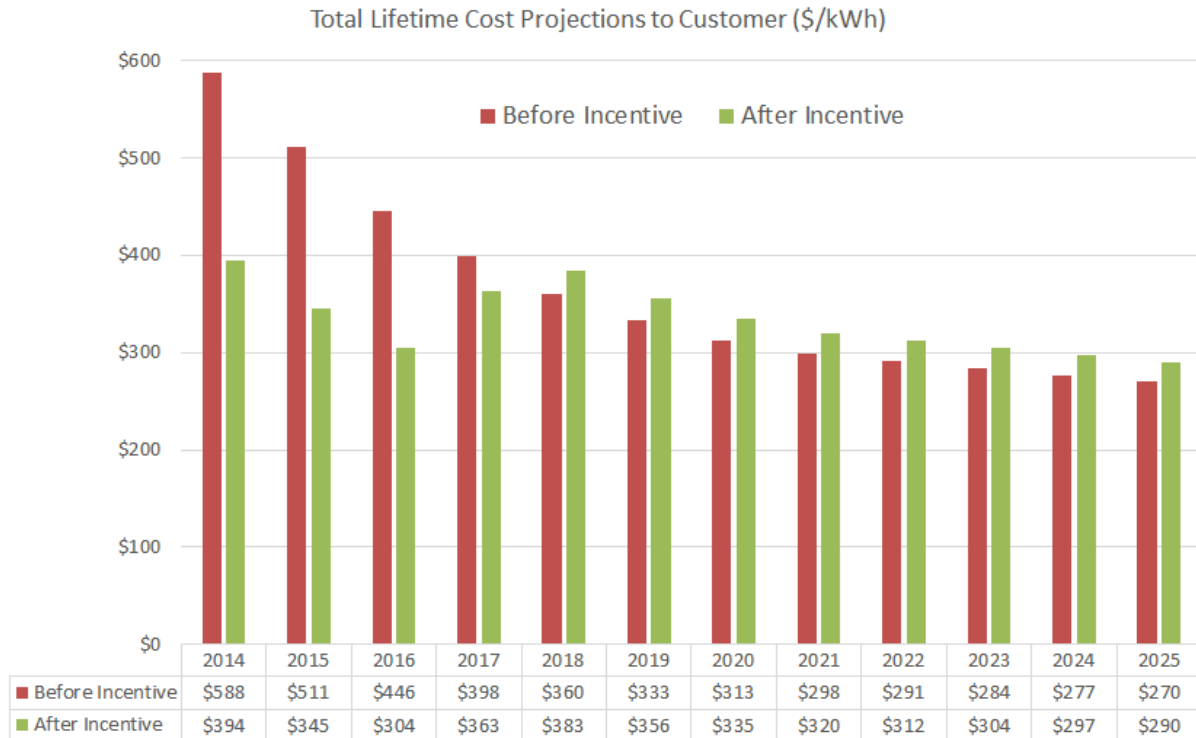

Figure ES 4: Battery Cost Projections

Energy Storage Analysis Approaches

In this section, we identify and demonstrate the application of distributed energy storage systems (DESS) for the selected distribution circuit. DESS can be used to obtain both system level benefits and customer level benefits.

For system level benefits, DESS are deployed to meet grid service objectives which are directly beneficial to utilities. These services may include substation upgrade deferral, line upgrade deferral, electricity price shift, enabling distributed energy resources (DER) integration, participating in the frequency regulation market (if implemented by LADWP), etc.

As for customer level benefits, DESS can be deployed at individual customer locations to meet objectives directly beneficial to customers. One such application is reducing the demand charge for the commercial customers. The demand charge is a billing mechanism used to recover the cost of providing transmission and distribution service to commercial customers and is calculated based on the largest peak demand recorded over a given month. Note that the per-kW demand charge is higher during the peak season and

high peak periods as compared to off-peak season and low peak periods. DESS are deployed to shift the power consumption from the high peak period to the low peak period, thus significantly reducing the monthly peaks and therefore the customers' demand charge.

The following sections illustrate both the system level and customer level benefits through multiple cases.

System-Level Analysis

The first task is to identify relevant system level benefits of DESS for the selected distribution circuit. For the scope of this report, the following four system level benefits are identified.

1. To defer substation transformer upgrade – Use DESS to prevent load from exceeding a given limit (e.g. rated capacity, planned loading limit, etc).
2. To defer distribution line upgrade under normal operating condition – Use DESS to prevent line overloading or exceeding a given limit
3. Facilitate emergency load condition – DESS can avoid distribution line overloading under an emergency load transfer condition.
4. Distributed energy resource (DER) integration - DESS can help integrate high penetration of distributed PV generation resources. If the load demand falls short of the total distributed generation, the DESS can be programmed to store the excess energy, therefore avoiding reverse power flow into the feeder.
5. Stacked Benefits – DESS can be used to decrease the cost of electricity in a real-time or time of use (TOU) price market.

Based on the above objectives, the following five test cases are simulated and evaluated. The circuit conditions for each test case and the key results are summarized as follows.

Case 1 – Using DESS to defer a substation transformer upgrade

The objective of this case is to defer substation upgrade by deploying a DESS and preventing the load demand from exceeding the substation transformer MVA rating. The DESS is programmed for peak load shaving, thus discharging when the load demand exceeds the transformer MVA rating. The substation upgrade will only be required once the peak load demand measured at the substation transformer increases to a value higher than the transformer's MVA rating (160 MVA). The analysis begins by identifying the year when the substation upgrade will be required. The analysis uses the load demand measured from 2013-2014 and adds an additional 1% load growth per year to project the peak load demands for years ranging from 2014-2015 to 2021-2022 (see Table ES 1).

Findings: The station selected for the study was very robust with a lot of capacity built in. Based on the analysis, from year 2013 – 2021, the projected peak load demand does not exceed substation transformer rating and thus a substation upgrade is not required. Energy storage is not required for substation transformer upgrade deferral.

Table ES 1: Projected peak load demand for RS-J Bank-D

Year	Peak Load	Percentage of transformer rating	Remaining transformer capacity
2013-2014	126.75 MW	79.22%	33.25 MW
2014-2015	128.02 MW	80%	31.98 MW
2015-2016	129.30 MW	80.81%	30.7 MW
2016-2017	130.59 MW	81.62%	29.41 MW
2017-2018	131.90 MW	82.44%	28.1 MW
2018-2019	133.22 MW	83.26%	26.78 MW
2019-2020	134.55 MW	84.1%	25.45 MW
2020-2021	135.89 MW	84.93%	24.11 MW
2021-2022	137.25 MW	85.78%	22.75 MW

Case 2 – Using DESS to defer distribution line upgrade

In this case study, we demonstrate how using DESS can defer a distribution line upgrade. It is assumed that DESS will be required if the line loading exceeds its rated normal ampacity (450 A). Similar to Case 1, line currents are projected to future years assuming 1% load growth. Based on projected line currents for years ranging from 2013-2014 to 2021-2022, it is observed that the largest line current does not exceed the line’s normal ampacity (see Table ES 2). Therefore, it is concluded that the line upgrade is not required until year 2022 and DESS is not required for this particular application.

Findings: The feeder selected for the study has a lot capacity and will not need ESS from year 2013 to 2021.

Table ES 2: Projected maximum line current for NR-CHA 5 feeder, 1% load growth per year

Year	Peak Load	Maximum line current	Remaining ampacity
2013-2014	16.33 MW	321.5 A	128.5 A
2014-2015	16.49 MW	324.71 A	125.29 A
2015-2016	16.66 MW	327.96 A	112.04 A
2016-2017	16.82 MW	331.24 A	118.76 A
2017-2018	16.99 MW	334.55 A	115.45 A
2018-2019	17.16 MW	337.9 A	112.1 A
2019-2020	17.33 MW	341.28 A	108.72 A
2020-2021	17.50 MW	344.69 A	105.3 A
2021-2022	17.68 MW	348.13 A	101.86 A

Case 3 – Using DESS to avoid distribution line overloading under emergency load transfer conditions

Another possible system application for DESS could be deployed to avoid line overloading under emergency load transfer conditions. Under an emergency load condition (shown in Figure ES 5), the maximum line current flowing through the feeder may exceed its normal ampacity. In such a situation, a DESS can be deployed upstream from the tie-line connecting the emergency load to provide the excess line current. The following case study was created: Peak load demand = 23.5 MW, Load transfer from another feeder = 7.5 MW, 2.5 MW (7.5MWh) of energy storage located downstream to supply for the excess load demand.

Findings: It was demonstrated that during emergency conditions maximum load can be transferred to NR CHA-5 without exceeding thermal rating limits. ES placement and size was demonstrated. It is

determined that it will be difficult to determine a monetary value of the avoided cost that LADWP will incur during emergency load transfer conditions. Therefore, energy storage cost evaluation was however not done for this case.

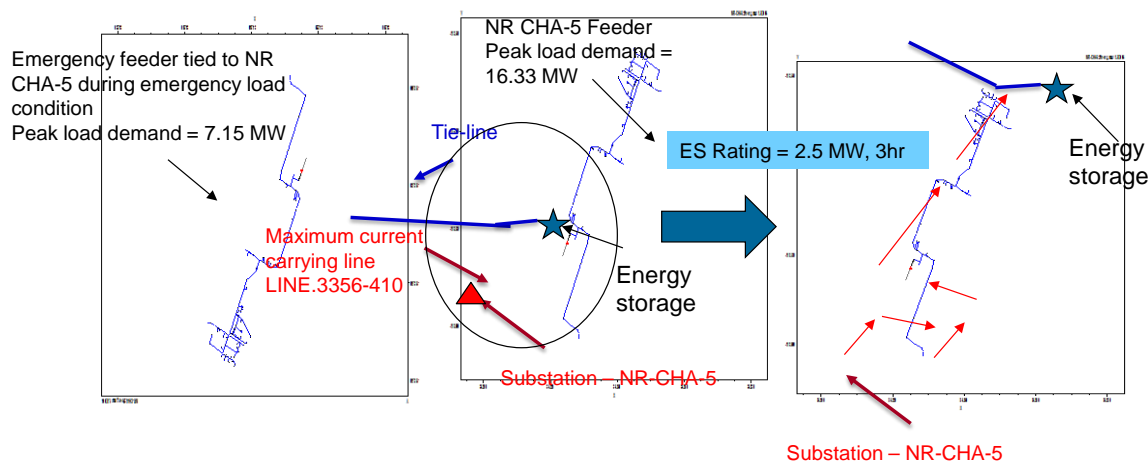

Figure ES 5. Energy Storage to Avoid Distribution Line Overloads under Emergency Load Transfer

Case 4 – Using DSS to Facilitate PV integration

This case study evaluates the effectiveness of DESS in mitigating the reverse power flow in feeders due to additional PV generation. The use of DESS to increase the circuit’s PV hosting capacity for reverse power flow criteria is also demonstrated. The reverse power flow happens when the total PV generation exceeds the feeder’s minimum load demand. In such a case, a DESS can be deployed and set to charge, thereby increasing the feeder load demand and thus mitigating the reverse power flow condition.

The analysis begins when the total PV generation is equal to the PV hosting capacity calculated for the reverse power flow criteria. Note that the calculated PV hosting capacity is equal to 5.3 MW (total PV generation), which consists of 3.749 MW of additional PV and 1.533 MW of existing PV. The analysis is done under minimum load conditions for feeder NR-CHA-5.

Findings: It was demonstrated that 2 energy storage systems could be utilized to avoid reverse power flow and increase feeder hosting capacity. Two 300-kW DESS are added to the feeder and are set to charge. It is observed that the active power flow at the feeder head increases from -7.6 kW to 550 kW after deploying DESS. The negative sign indicates power flows in the upstream direction towards the substation. Next, the new PV hosting capacity for the circuit after adding DESS is calculated. The analysis shows that when DESS is added, the feeder’s PV hosting capacity increases from 5.282 MW to 5.879 MW. The energy storage will eliminate the upgrades needed for protection equipment. Energy storage can also be utilized for voltage support functions in conjunction with PV inverters. It is determined that it will be difficult to determine a monetary value for this case. Therefore, energy storage cost evaluation was not done for this case.

Case 5- Deploying DESS to provide stacked benefits including substation upgrade deferral, line upgrade deferral, electricity price shift, and regulation services

In this case study, several DESS applications are combined to provide stacked benefits for the distribution circuit. Here, DESS are sized and programmed to provide the following combined benefits.

1. Avoided cost of a substation upgrade – The benefits are obtained by deferring the substation transformer upgrade using DESS. DESS are deployed to prevent the substation load from

exceeding a specified transformer loading limit. In this analysis, the load demand should not exceed 90% of the substation transformer MVA rating (160 MVA).

2. Avoided cost of distribution line upgrades – The benefits are obtained by deferring the distribution line upgrade using DESS. DESS are deployed in order to prevent the line current from exceeding a specified current limit. The current limit considered in this analysis is equal to 80% of the line's normal ampacity (450 A).
3. TOU time-shift/electricity price time-shift – In a real time price market, DESS can be charged when the rates are low and discharged when the rates are high. The benefit is obtained due to reduction in the total electricity price.
4. Regulation Services – Provide ancillary services for regulation based on LADWP's open access transmission tariff with on-peak (\$0.31/MW for the hour) and off-peak (\$0.15/MW for the hour) rates. DESS will be paid for simply making their capacity available for frequency regulation.

Here, the analysis is done at the substation level for the circuit supplied by RS-J Bank-D. The peak load demands recorded for Year 2013-2014 are projected to future years. Assuming a 2% load growth from Year 2013 to 2019 and a 1% load growth beyond Year 2019, yearly load demands are projected up to Year 2022. Also, for each future year, the maximum line currents flowing through each distribution line are calculated. The peak load demand projected for Year 2020 is 143.91 MW, which is greater than the specified transformer loading limit (90% of 160 MVA = 143.84 MVA). Therefore substation upgrade will be required starting from Year 2020.

The primary objective of deploying DESS is to defer the substation upgrade for 3 years (2020 through 2022), i.e. up to Year 2022. Therefore, based on substation and line upgrade requirements for year 2022, DESS capacity (MW) and duration are calculated. A DESS with 2.9 MW capacity and 1.4 hour duration is required to defer the substation upgrade until Year 2022. Next, DESS controls are designed to obtain the required stacked benefits. The primary objective is to avoid substation and line overloading. If transformer or line overloading limits are violated, DESS are deployed for peak shaving objective. On the other hand if it is not required to meet the peak shaving objective, DESS are programmed to meet electricity price time-shift operations and frequency regulation services.

Figure ES 6, Table ES 3, and Table ES 4 provides the cost-benefit results for the stacked benefit case. We assumed a low capital cost of \$270/kWh and battery replacement every five years with the replacement cost of \$254/kWh. We assumed DESS life span to be 15 years.

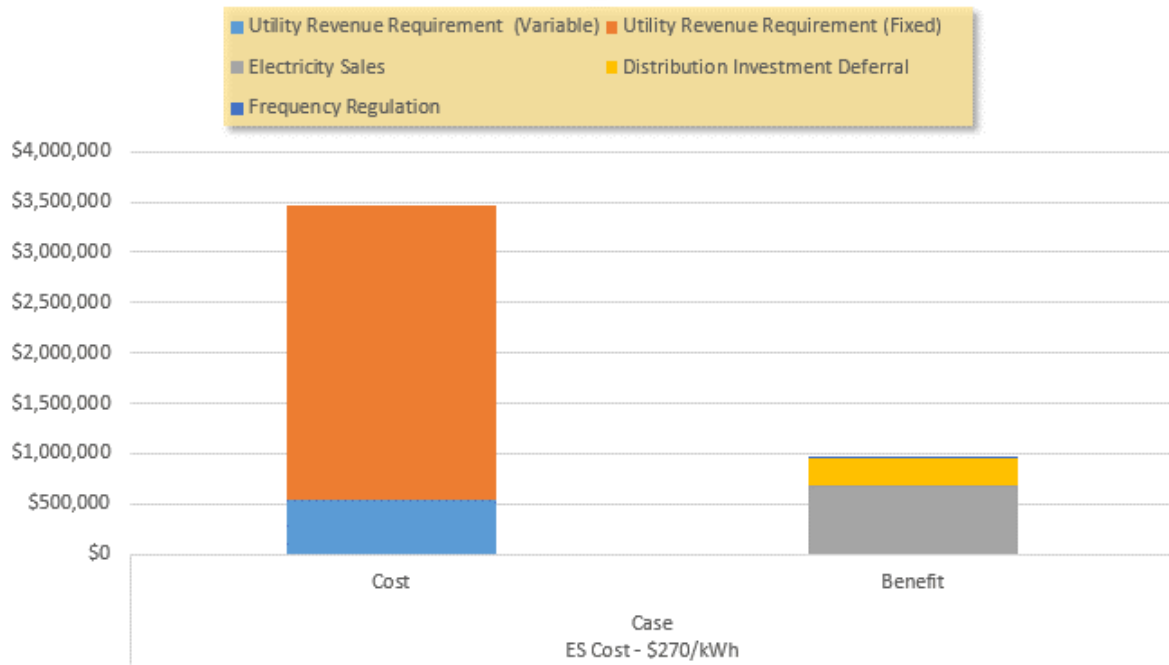

Figure ES 6: Total Cost and Benefit Results for the Stacked Benefit Case

Table ES 3: Total Cost and Benefit Breakdowns from ESVT Runs

	Cost	Benefit
Utility Rev. Requirement (Variable)	\$535,972	\$0
Utility Rev. Requirement (Fixed)	\$2,925,221	\$0
Electricity Sales	\$0	\$677,618
Distribution Investment Deferral	\$0	\$283,371
Frequency Regulation	\$0	\$10,134
Total	\$3,461,193	\$971,123

Table ES 4: Annual Service Revenue Breakdown for the different Services over 15 years

Year	Distribution Investment Deferral	Frequency Regulation	Electric Energy Time-Shift (Arbitrage)
1	\$109,000	\$964	\$13,400
2	\$109,000	\$992	\$13,900
3	\$109,000	\$1,022	\$14,300
4	\$0	\$1,053	\$14,700
5	\$0	\$1,085	\$15,100
6	\$0	\$1,118	\$15,600
7	\$0	\$1,151	\$16,100
8	\$0	\$1,186	\$16,500
9	\$0	\$1,221	\$17,000
10	\$0	\$1,258	\$17,600
11	\$0	\$1,296	\$18,100
12	\$0	\$1,334	\$18,600
13	\$0	\$1,375	\$19,200
14	\$0	\$1,416	\$19,800
15	\$0	\$1,458	\$20,400

Findings: Even though DESS is successfully able to perform peak shaving functions and mitigate the transformer and line overloading concerns, participate in the frequency and energy time-shift market, it is clear that this is not cost-effective. The storage system will not be able to generate enough revenue to cover its cost. Table ES 4 and Figure ES 8 shows the annual service revenue that the storage system generated throughout its fifteen years lifetime. For the distribution investment deferral case, the storage system was used to keep load under the threshold of 143.840 MW, which will allow LADWP to defer the 1 million dollar upgrade investment on their substation transformer and about 1.4 miles of line conductor upgrade @\$800k/mile. The total cost of upgrade is 2.12 million dollars. This threshold is calculated as 89.9% of the substation transformer rating. The project beginning year is 2020, as shown in the table above, the storage was able to defer the upgrade from year 2020 to 2022. Starting from 2023, an upgrade would be needed for the transformer. The value the storage system provides from this service is equal to the savings from delaying the investment on the substation upgrade.

The annual frequency regulation revenue is about \$1000 per year. To provide this services, ESVT decides how much capacity to provide into the frequency regulation market based on the frequency regulation capacity prices, the actual energy throughput for this service is calculated based on the AGC signal, for this case, we used a ESVT default CAISO AGC signal as a proxy, which as an average hourly energy throughput of about 17%. For the actual frequency regulation capacity price, we used the prices provided by LADWP, with the on peak regulation price being \$0.31/MWh and off-peak regulation price being \$0.15/MWh. With the low frequency regulation prices in LADWP, the revenue from this service is the lowest among the three services.

The third service that the storage system is providing is electric energy time-shift. The storage charge-discharge schedule for this service is co-optimized with that of the frequency regulation service. LADWP provided their hourly marginal energy cost in 2013 in their service area, we escalated this cost by 3% every year to 2020 (project beginning year) level for the purpose of this case. The average energy prices is about \$28/MWh, which explains the higher energy time-shift annual revenue compared to frequency regulation.

Figure ES 8 shows the storage dispatch for one year, it is clear that the storage system can provide regulation and frequency response service and that the economic value for providing this service in LADWP's service territory is measured by assessing the cost incurred by LADWP for providing similar service to its native load using regulation service rates under the LADWP's tariff. However, the same energy storage can provide higher revenue stream under an open and competitive market such as the CAISO Frequency Regulation Market.

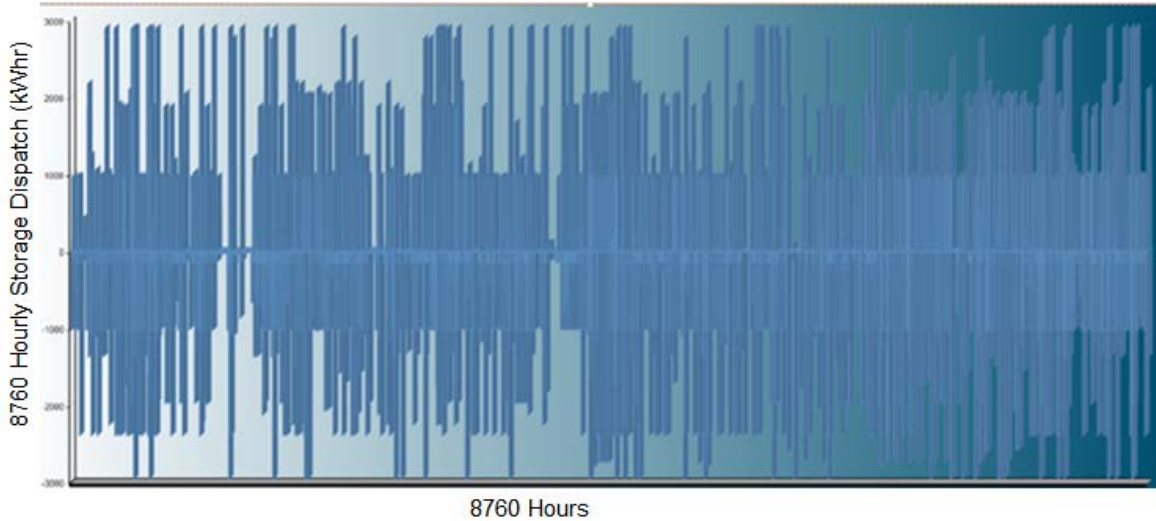

Figure ES 7: Energy Storage Annual Dispatch

Figure ES 9 shows the load before and after storage dispatch on one of the days that the storage system dispatched to shave peak for distribution investment deferral.

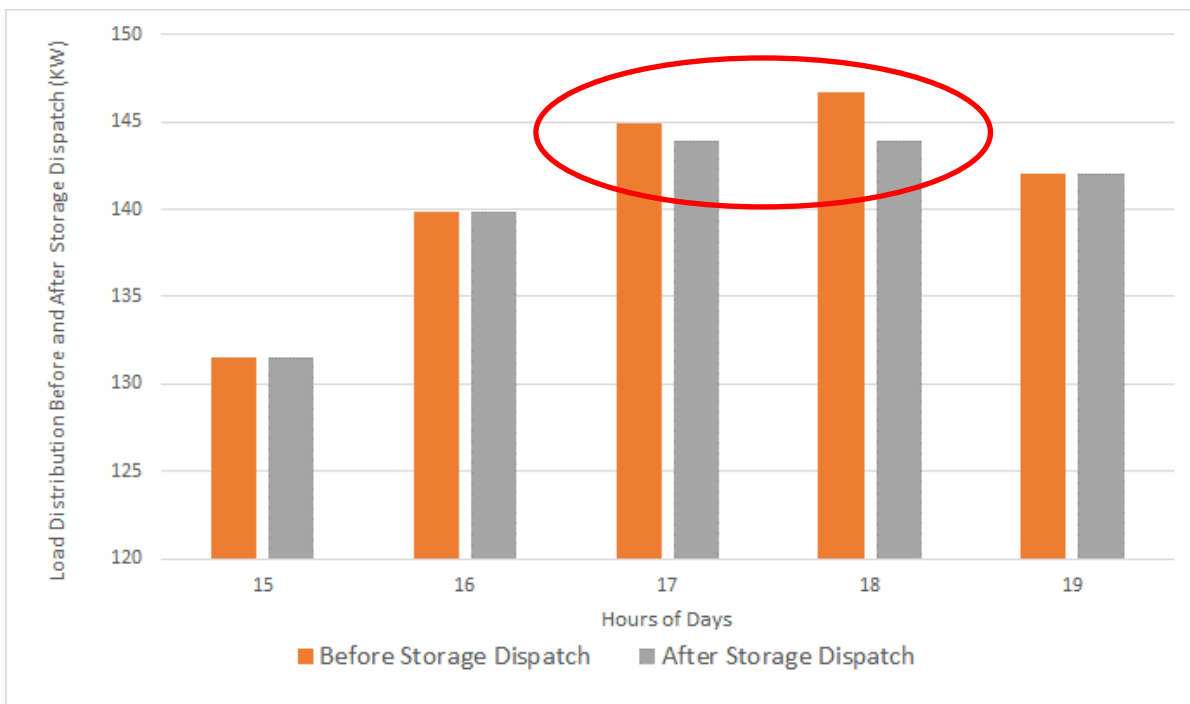

Figure ES 8: Energy Storage Dispatch for Peak Shaving Service

Customer Level Benefits

The selected 34.5 kV distribution feeder, NR-CHA-5, is supplying for 39 commercial loads. Utilities charge commercial customers with an additional demand charge based on their monthly peak load demand. The demand charge also depends upon the season (peak or off-peak) and the time of the day (high peak or low peak period). The demand charge periods and per-kW demand charge for both peak and off-peak season are shown in Table ES 5 and Table ES 6. The total monthly demand charge is the sum of the demand charge calculated for both high peak and low peak periods.

Table ES 5: Demand Charge Periods

Demand periods	
High peak period	1 pm – 5 pm Monday – Friday
Low peak period	10 am – 1 pm Monday – Friday 5 pm – 8 pm Monday – Friday
Base period	8 pm – 10 am Monday-Friday, All day Saturday Sunday

Table ES 6: Demand charge per-kW of peak load demand

Demand Charge	Peak Season – June - Sept	Off-Peak Season – Oct - May
High peak period	\$ 9.7/kW	\$ 4.3/kW
Low peak period	\$ 3.3/kW	\$ 0/kW
Base period	\$ 0/kW	\$ 0/kW

Findings: As part of this analysis, 5 commercial customers DESS application at Customer level were evaluated for Demand Charge Reduction service. As part of the demand charge reduction service, DESS was utilized is to shift the peak load demand recorded during high demand charge periods to low demand charge periods using DESS and thereby reducing the total demand charge for the individual customer. It was observed that DESS benefits differ from one customer site to the other. Not all the sites benefit from DESS based on present cost. Results are provided to illustrate at what price point ES is cost effective. Furthermore, additional demand charge reductions obtained from PV are also illustrated. One key conclusion from all the 5 customer sites is that a long discharge time of DESS is required to avoid demand charge. Payback time is too long to be cost effective

Customer Level Deployment Scenarios Studied include:

- Largest commercial customers
 - Load #39 – ID 2531688: Peak Load hours – 5 pm to 5 am
 - Load #16 – ID 2531663: Peak Load hours – 5 pm to 6 am
 - PVs are unlikely to play a significant role in reducing peak demand load for these two customers because their peak loads occur during evening hours.
- To evaluate the combination of PV & Energy Storage two other loads are selected because they have peak loads during daylight hours
 - Load #12 (ID 2531768)

- Load #14 (ID 2531739)

In this section, the following two case studies are simulated.

Case 1 - Demand charge reduction due to DESS

In this case, the demand charge reductions obtained only due to DESS are evaluated. The DESS kW capacity is calculated by subtracting the average monthly peak load demand recorded during the peak season from the one obtained during the off-peak season. Among the 39 commercial loads, the five largest customer loads are selected and the use of DESS to reduce their demand charge is demonstrated. The DESS capacity (in terms of kW) is calculated for each of the selected load locations. The DESS energy (in terms of duration) is then increased in 1 hour steps, and demand charge is calculated with and without DESS for each selected load location. Finally, the optimal DESS duration resulting in the maximum decrease in customer demand charge is selected (see Table ES 7).

Table ES 7 Demand Charge reduction due to DESS

Load ID	Peak Load Demand	Daily Peak Shaved	DESS Capacity	Optimal DESS Duration	Total reduction in demand charge (\$)
2531688	1621.906 kW	292 kW	292 kW	4/5 hours	\$3,643.06
2531663	1610.706 kW	500 kW	500 kW	4/5 hours	\$3,121.50
2531768	803.56 kW	140 kW	370 kW	4/5 hours	\$9,609.02
2531739	796.46 kW	300 kW	300 kW	4/5 hours	\$23,794.01
2531577	453.36 kW	120 kW	120 kW	4/5 hours	\$9,177.13

Table ES 8: ESVT Results for Load 39 based on 2014, 2018, and 2025 Lithium Ion Battery Cost Projections shown in Figure ES-4

Load	ES Size (kW)	ES Duration (hr)	ES Total Cost (\$/kWh)	Life Time Plant Cost (\$)	Benefit (\$)
39	292	4	\$ 588	\$ 710,957.62	\$ 39,632.80
			\$ 360	\$ 440,392.75	
			\$ 270	\$ 333,590.83	
			\$ 180	\$ 226,788.91	

Findings: For this specific customer to be cost effective to install 292KW 4hr ES system the cost of storage needs to be <\$30/kWh which is quite less than the projected lithium ion battery cost for year 2025 as shown in Figure ES 4.

Table ES 9: ESVT Results for Load 16 based on 2014, 2018, and 2025 Battery Cost Projections shown in Figure ES-4

Load	ES Size (kW)	ES Duration (hr)	ES Total Cost (\$/kWh)	Cost	Benefit
16	500	4	\$ 588	\$ 1,217,393.18	\$ 40,497.37
			\$ 360	\$ 754,097.18	
			\$ 270	\$ 571,217.18	
			\$ 180	\$ 388,337.18	

Findings: For this specific customer to be cost effective to install 500KW 4hr ES system the cost of storage needs to be <\$15/kWh which is quite less than the projected lithium ion battery cost for year 2025 as shown in Figure ES 4.

Case 2 - Demand charge reduction due to PV and DESS

PV systems can significantly decrease the peak load demand recorded during daylight hours. The daylight hours coincide with the high peak period for demand charge rates, i.e. 1 pm – 5 pm. Therefore, for the commercial loads recording peak load demand during daylight periods, a PV system can be deployed to reduce a customers’ demand charge. A DESS can also be added to obtain additional demand charge reductions. This case study illustrates the combined benefits of deploying PV and DESS. Based on the yearly load demand profile, two loads recording peak load demand during daylight hours are selected for the analysis: Load #12 (ID 2531768) and Load #14 (ID 2531739). At both load locations, a 166 kW PV generation system is installed. The demand charge reduction with only PV and with both PV and DESS are calculated and shown in Table ES 10. The results demonstrate that by deploying both PV and DESS, a significant reduction in demand charge can be obtained.

Table ES 10: Demand Charge reduction due to PV and DESS

Load Number	Load Name	Demand Charge with no PV or DESS	Demand Charge with PV	Demand Charge with DESS and PV	Reduction in Demand Charge due to PV and DESS
12	2531768	\$ 61,045.37	\$ 56,085.23	\$ 49,946.97	\$ 11,098.40
14	2531739	\$ 63,879.98	\$ 50,346.35	\$ 39,405.69	\$ 24,474.29

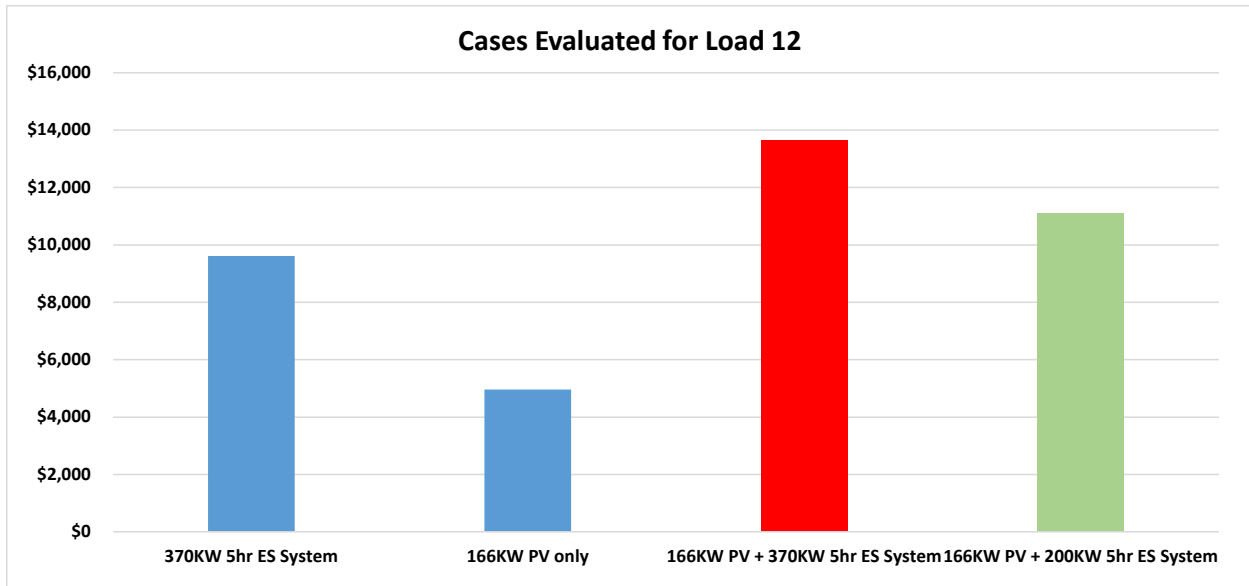

Figure ES 9: Cost Comparisons for Load 12

Table ES 11: ESVT Results for Load 12 based on 2025 Battery Cost Projection shown in Figure ES-4

Load	ES Size (kW)	ES Duration (hr)	ES Total Cost (\$/kWh)	Life Time Plant Cost (\$)	Benefit (\$)
12	200	4	\$270	\$228,486	\$85,542
			\$85	\$85,542	

Findings: For this specific customer to be cost effective to install 292KW 4hr ES system the cost of storage needs to be ~\$85/kWh which is quite less than the projected lithium ion battery cost for year 2025 as shown in Figure ES 4.

Table ES 12: ESVT Results for Load 14

Load	ES Size (kW)	ES Duration (hr)	ES Total Cost (\$/kWh)	Life Time Plant Cost (\$)	Benefit (\$)
14	200	4	\$270	\$228,486	\$152,897
			\$160	\$152,897	

Findings: For this specific customer to be cost effective to install 292KW 4hr ES system the cost of storage needs to be ~\$160/kWh which is quite less than the projected lithium ion battery cost for year 2025 as shown in Figure ES 4.

Conclusion

Sharp declines in the price of solar photovoltaic generation systems and lithium ion battery storage have led to new options for electricity customers.

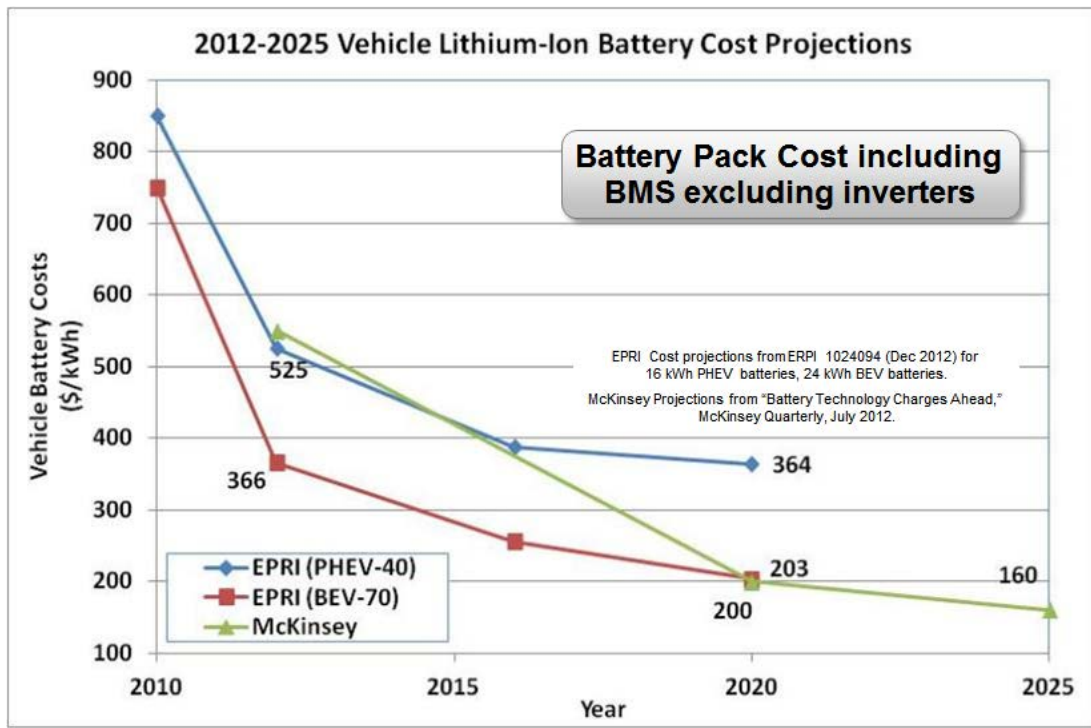

Figure ES 10: Energy Storage Battery Pack Cost Projections

Storage can potentially make the grid more flexible

- Provide a buffer between generation and loads
- Reduces the strain on grid assets
- Allows the grid to accommodate more variable renewable energy

This project developed a detailed methodology and data analytics necessary to evaluate various deployments scenarios of energy storage. The analysis was carried out on one of the 34.5KV feeders within LADWP service territory. The methodology covered both the impact as well as value analysis. The energy storage analysis was conducted for storage deployed at system level as well as customer sited. Procedure to conduct impact and value analysis to realize the “stacked benefits” of storage were also conducted.

The station selected for the study was very robust with a lot of capacity built in. This provided a challenge to justify the system level storage installation for capacity and energy based services. It was also demonstrated that during emergency conditions maximum load can be transferred to feeder under this study without exceeding thermal rating limits. ES placement and size was demonstrated.

Five commercial customer level energy storage applications for demand charge reduction were also evaluated. As part of the demand charge reduction service, DESS was utilized to shift the peak load demand recorded during high demand charge periods to low demand charge periods using DESS and thereby reducing the total demand charge for the individual customer. It was observed that DESS benefits

differ from one customer site to the other. Not all the sites benefit from DESS based on present cost. Results are provided to illustrate at what price point ES is cost effective. Furthermore, additional demand charge reductions obtained from PV are also illustrated. One key conclusion from all the 5 customer sites is that a long discharge time of DESS is required to avoid demand charge. Payback time is too long to be cost effective.

Export Control Restrictions

Access to and use of EPRI Intellectual Property is granted with the specific understanding and requirement that responsibility for ensuring full compliance with all applicable U.S. and foreign export laws and regulations is being undertaken by you and your company. This includes an obligation to ensure that any individual receiving access hereunder who is not a U.S. citizen or permanent U.S. resident is permitted access under applicable U.S. and foreign export laws and regulations. In the event you are uncertain whether you or your company may lawfully obtain access to this EPRI Intellectual Property, you acknowledge that it is your obligation to consult with your company's legal counsel to determine whether this access is lawful. Although EPRI may make available on a case-by-case basis an informal assessment of the applicable U.S. export classification for specific EPRI Intellectual Property, you and your company acknowledge that this assessment is solely for informational purposes and not for reliance purposes. You and your company acknowledge that it is still the obligation of you and your company to make your own assessment of the applicable U.S. export classification and ensure compliance accordingly. You and your company understand and acknowledge your obligations to make a prompt report to EPRI and the appropriate authorities regarding any access to or use of EPRI Intellectual Property hereunder that may be in violation of applicable U.S. or foreign export laws or regulations.

The Electric Power Research Institute, Inc. (EPRI, www.epri.com) conducts research and development relating to the generation, delivery and use of electricity for the benefit of the public. An independent, nonprofit organization, EPRI brings together its scientists and engineers as well as experts from academia and industry to help address challenges in electricity, including reliability, efficiency, affordability, health, safety and the environment. EPRI also provides technology, policy and economic analyses to drive long-range research and development planning, and supports research in emerging technologies. EPRI's members represent approximately 90 percent of the electricity generated and delivered in the United States, and international participation extends to more than 30 countries. EPRI's principal offices and laboratories are located in Palo Alto, Calif.; Charlotte, N.C.; Knoxville, Tenn.; and Lenox, Mass.

Together...Shaping the Future of Electricity

© 2014 Electric Power Research Institute (EPRI), Inc. All rights reserved.
Electric Power Research Institute, EPRI, and TOGETHER...SHAPING THE
FUTURE OF ELECTRICITY are registered service marks of the Electric
Power Research Institute, Inc.

This space is intentionally left blank

Appendix 6

Maximum Renewable Energy Penetration Report

This space is intentionally left blank



Final Report

Maximum Renewable Energy
Penetration Study: Tasks 1-7

Los Angeles Department of Water and Power

December 23, 2013



Final Report

Maximum Renewable Energy Penetration Study: Tasks 1-7

Los Angeles Department of Water and Power

December 23, 2013



This report has been prepared for the use of the client for the specific purposes identified in the report. The conclusions, observations and recommendations contained herein attributed to Leidos constitute the opinions of Leidos. To the extent that statements, information and opinions provided by the client or others have been used in the preparation of this report, Leidos has relied upon the same to be accurate, and for which no assurances are intended and no representations or warranties are made. Leidos makes no certification and gives no assurances except as explicitly set forth in this report.

© 2013 Leidos, Inc.
All rights reserved.

Maximum Renewable Energy Penetration Study: Tasks 1-7

Los Angeles Department of Water and Power

Table of Contents

Letter of Transmittal

Table of Contents

List of Tables

List of Figures

Executive Summary

Study Results	ES-1
LADWP Basin Capability to Accept Renewables	ES-2

Section 1 Task 1: Case Development

Initial Models	1-1
Assumptions	1-1

Section 2 Task 2: Steady State Power Flow Study - Baseline

Contingency Lists	2-1
N-1 and N-2 Contingencies	2-1
N-1-1 Contingencies	2-1
Heavy Summer Case	2-2
Thermal Results	2-2
Voltage Results – Heavy Summer	2-4
Heavy Spring Case	2-5
Thermal Results	2-5
Voltage Results – Heavy Spring	2-7
Light Winter Load Case	2-7
Thermal Results	2-7
Voltage Results – Light Winter	2-8

Section 3 Task 3: Post-Transient Voltage Stability Study - Baseline

Contingency List	3-2
Heavy Summer Case	3-4
Heavy Spring Case	3-6
Light Load Case	3-8

Section 4 Task 4: Dynamic Stability Study - Baseline

Contingency List	4-2
Heavy Summer Case	4-3
Heavy Spring Case	4-7
Light Load Case	4-10

TABLE OF CONTENTS

Section 5 Tasks 5-7: Maximum Renewable Energy Penetration Study	5-1
Transmission System Stress Evaluation	5-1
BRI Path MREPS Stress Cases	5-3
MREPS Stress Cases.....	5-6
Highlighted Results.....	5-11
Powerflow Simulations.....	5-11
Post-Transient Simulations	5-12
Dynamic Stability Simulations.....	5-12
Section 6 System Reliability Issues - Backdrop.....	6-1
Section 7 Summary and Recommendations	7-1
LADWP Basin Capability to Accept Renewables.....	7-1
Recommendations.....	7-2
2020 Seed Cases – Observations and Issues	7-2
Barren Ridge – Inyo 230-kV Path Renewables	7-3
MREPS Stress Cases – Observations and Issues.....	7-3
MREPS Stress - Barren Ridge – Inyo 230-kV Path Renewables	7-4

List of Appendices

A	Steady State Study N-1 Base Cases
B	Initial Case Steady State Study Result Tables
C	Steady State Study Contingency Lists
D	N-1-1 Methodology for Determining N-1 Base Cases
E	Initial Case Post-Transient Voltage Stability Study Result Tables
F	Initial Case Dynamic Stability Study Plots
G	MREPS Steady State Result Tables
H	MREPS Post-Transient Voltage Stability Study Result Tables
I	MREPS Dynamic Stability Study Plots

List of Tables

Table ES-1 MREPS Tasks 1-1

Table 1-1 PSLF Power Flow Generation 1-1

Table 1-2 LADWP System Characteristics 1-2

Table 1-3 Transfer Levels 1-2

Table 2-1 Summer Single Contingency Thermal Highlights 2-2

Table 2-2 Summer Double Contingency Thermal Highlights 2-3

Table 2-3 Summer N-1-1 Contingency Thermal Highlights Initial
Contingency of Tarzana 230/138 kV Transformer 2-3

Table 2-4 Summer N-1-1 Contingency Thermal Highlights Initial
Contingency of Toluca E. to Hollywood E. 230 kV Circuit 1 2-4

Table 2-5 Spring Single Contingency Thermal Highlights 2-5

Table 2-6 Spring Double Contingency Thermal Highlights 2-6

Table 2-7 Spring N-1-1 Contingency Thermal Highlights Initial Contingency
of Victorville to Century 287 kV #1 or #2 2-7

Table 2-8 Light Load N-1-1 Contingency Thermal Highlights Initial
Contingency of Sylmar to Sylmar S 230kV #G Transformer 2-8

Table 2-9 Light Load N-1-1 Contingency Voltage Highlights Initial
Contingency of Castaic 12 to Haskell Canyon 230 kV Ckt. 1 2-9

Table 3-1 WSCC Voltage Stability Criteria 3-1

Table 3-2 Voltage Stability Contingency List 3-2

Table 3-3 Voltage Stability Bus and Contingency Combinations 3-3

Table 3-4 Voltage Stability – Summer – Worst Case Scenarios 3-5

Table 3-5 Voltage Stability – Summer – Results 3-5

Table 3-6 Voltage Stability – Summer – Results After Mitigations 3-6

Table 3-7 Voltage Stability – Spring – Worst Case Scenarios 3-7

Table 3-8 Voltage Stability – Spring – Results 3-7

Table 3-9 Voltage Stability – Light Load – Worst Case Scenarios 3-8

Table 3-10 Voltage Stability – Light Load – Results 3-9

Table 4-1 WECC Disturbance Performance Criteria 4-1

Table 4-2 Dynamic Stability Contingency List 4-2

Table 4-3: Dynamic Stability Results – Heavy Summer 4-4

Table 4-4: Dynamic Stability Results – Heavy Spring 4-7

Table 4-5: Dynamic Stability Results – Light Load 4-10

Table 5-1 BRI Path Queued MREPS Generation Additions 5-3

Table 5-2 LADWP Mitigated Heavy Summer 2020 Case Characteristics 5-3

Table 5-3 LADWP Mitigated Heavy Summer 2020 RMR Generation 5-4

Table 5-4 MREPS Stress Cases 5-6

Table 5-5 BRI Path MREPS Cases Generation 5-7

Table 5-6 - LADWP System Characteristics – BRI Path MREPS Stress
Cases 5-7

Table 5-7 – Transfer/Path Flow – BRI Path MREPS Stress Cases 5-8

Table 5-8- LADWP System Characteristics – East 500-kV MREPS Stress
Cases 5-10

Table 5-9 - Transfer Levels– East 500-kV MREPS Stress Cases 5-10

TABLE OF CONTENTS

Table 5-10 - EAST 500 VIC-LA Stress Cases	5-10
Table 5-11 - Transfer Levels - EAST 500 VIC-LA Stress Cases.....	5-11
Table 5-12 BRI Path MREPS Case Critical Clearing Times	5-14
Table 5-13 BRI Path MREPS Cases - Frequency Regulation.....	5-14
Table 5-14 East 500-kV MREPS Case Critical Clearing Times	5-15
Table 5-15 East 500-kV MREPS Cases - Frequency Regulation.....	5-16
Table 6-1 – Frequency and Size of 1-Minute Ramps for LADWP Queue PV Gen.....	6-2

List of Figures

Figure ES-1: Locations of Renewable Energy ES-3
Figure 4-1: Voltage Performance Parameters 4-2
Figure 5-1 – Barren Ridge – Inyo Path Connection Detail 5-9

EXECUTIVE SUMMARY

The Los Angeles Department of Water and Power (“LADWP”) is in the process of increasing its renewable energy resources in order to comply with California’s Renewable Portfolio Standards (“RPS”). LADWP needs to know how the system will handle these increases and develop strategies to incorporate new renewables effectively. Leidos has been tasked with assisting LADWP by performing a Maximum Renewable Energy Penetration Study (“MREPS”) to: (1) determine the maximum renewable penetration on the LADWP transmission system, (2) identify transmission or system constraints that limit renewable production, and (3) recommend the most efficient strategies for operating renewable resources. The work performed is comprised of several tasks including developing cases and performing steady state power flow, post-transient voltage stability, and dynamic stability analyses and are listed in Table ES-1.

**Table ES-1
MREPS Tasks**

Task No.	Task Name
Task 1	Case Development
Task 2	Steady State Power Flow Study
Task 3	Post-Transient Voltage Stability Study
Task 4	Dynamic Stability Study
Task 5	Maximum Renewable Energy Penetration Study
Task 6	System Reliability Study
Task 7	Minimum Reliability Must-Run Study
Task 8	Short Circuit Study
Task 9	Development of Composite Load Models
Task 10	Dynamic Stability Study with Composite Load Models
Task 11	Transient Stability Study with Composite Load Models

This report details the work performed, and the results of, Tasks 1 through 7. Accordingly, the sections of this report correspond to these tasks. In this report, the terms “renewables” or “renewable generation” refers to the grid-level renewable plants remote from the mail LADWP load center.

Study Results

This study tested the capability of the LADWP Bulk Electric System (“BES”) to support incorporation of renewable energy in two stages. The first stage required the addition of roughly 1210 MW of renewable generation to a projected set of 2020 cases. These cases were a Heavy Summer, Heavy Spring, and a Light Winter (Mid-day weekend) case and included load forecasts associated with those conditions as

well as planned transmission and generation projects up to the 2020 timeframe. These were referred to as the “seed cases” and the 1210 MW constituted a set of projects from LADWP’s interconnection queue.

Leidos conducted power flow, dynamic stability, and post-transient stability analyses on the seed cases to assess the impact of the renewables. Following this evaluation, Leidos established mitigating actions for any system performance issues that were found, established Reliability Must Run generation associated with these cases, and subsequently sought to incorporate additional renewables, creating a set of “MREPS Stress cases” – one set for renewables in the Barren Ridge – Inyo path (BRI Path cases) and one set for renewables added to select 500-kV substations in the El Dorado Valley near Las Vegas. Figure ES-1 shows the locations of the proposed future renewable energy.

The questions to be answered were as follows:

1. What is the maximum renewable penetration of the LADWP BES without additional system upgrades (upgrades beyond those already planned for 2020)?
2. What is the maximum renewable energy penetration of the LADWP BES with reasonable upgrades planned?

LADWP Basin Capability to Accept Renewables

- *The study results indicate that the planned 1210 MW of generation in the LADWP queue, combined with in-basin RMR, effectively constituted the maximum renewable energy that the system can accommodate without upgrades.*

The study also found several performance issues local to the Barren Ridge- Inyo 230-kV path – a known issue for LADWP staff. These issues are separate from the in-basin transmission constraints that drive the need for RMR generation.

Maximum Renewable Energy Penetration with Upgrades

Following completion of the upgrades described in Section 5 of this report, the amount of additional renewable generation that can be accommodated is essentially limited to the amount that LADWP can offset with internal traditional generation. This is true regardless of the location of the proposed renewables, with the BRI Path renewables requiring substantially more system upgrades due to the electrical weakness of that transmission path. The MREPS stress cases added 740 MW of additional renewables.

- *The ability of the LADWP in-basin system to offset renewable generation in these cases was roughly 780 MW, making the total Maximum Renewable Energy Penetration 1990 MW if the proposed upgrades are completed.*

It should also be noted that the amount of renewable energy that can be accommodated will be seasonally dependent – accommodating renewables in the MREPS Heavy Spring and Light Winter cases required changes in interchange. Furthermore, the amount of renewable energy that can be accommodated would depend on load growth – if load forecasts are higher, more renewable energy can be

accommodated, subject to the critical clearing time and frequency regulation issues discussed below.



Figure ES-1: Locations of Renewable Energy

Detailed results of each phase of the study can be found in the Appendices, and detailed recommendations for technical performance issues observed are located in Section 8 – Summary and Recommendations.

Section 1

Task 1: Case Development

LADWP provided Leidos with three PSLF cases representing the LADWP system in 2020 under heavy summer, heavy spring, and light load conditions. Utilizing these cases, Leidos added a baseline amount of known queued renewable generation, modified dispatch, voltage, regulation, shunt and other system conditions to accommodate this queued generation and conduct the studies in Tasks 2 through 4. The models used for the MREPS are discussed in this section.

Initial Models

Leidos conducted simulations on three PSLF models provided by LADWP, representing a heavy summer peak load, heavy spring load, and light load conditions in the area of study in the projected 2020 year timeframe. These models were provided in .sav case format with the names “23hsl_UNIFIED_MODEL_10-01-2013.sav” (summer peak), “MREPS_18HSP_JW_10-09-2013_revision_d.sav” (heavy spring), and “LW2020_101613.sav” (light winter).

Assumptions

For the MREPS study, Leidos increased the LADWP area renewable generation by adding 1,210 MW including collector system details where needed and adjusted generation and imports to keep LADWP area bus voltages (for buses 100 kV or greater) to a voltage of 0.99 or above. No elements were loaded to a level greater than their normal rating (i.e., Rating 1). Table 1-1 below summarizes the total generation output from the new renewables and LA Basin existing synchronous generation.

Table 1-1
PSLF Power Flow Generation

Generator Station	Summer Pgen (MW)	Spring Pgen (MW)	Light Load Pgen (MW)
Beacon PV	500.0	500.0	500.0
Copper Mountain PV	250.0	250.0	250.0
Q09 PV	150.0	150.0	150.0
Q11 PV	60.0	60.0	60.0
Moapa Solar	250.0	250.0	250.0
Castaic	8.1	40.5	23.7
Haynes	580.0	0.0	0.0
Valley	0.0	0.0	0.0
Scattergood	200.0	0.0	0.0

Section 1

Harbor	0.0	0.0	0.0
--------	-----	-----	-----

Table 1-2 below summarizes the LADWP system characteristics in the load flow models used in this study. These characteristics include installed capacity, on-line generation, load, losses, and net scheduled interchange.

**Table 1-2
LADWP System Characteristics**

LADWP Generation	Heavy Summer (MW)	Heavy Spring (MW)	Light Winter Load (MW)
On-line Capacity	5,483.8	4,310.8	4,335.8
Dispatched MW	4,605.0	3,622.5	3,676.5
Load	6,595.1	4,212.7	2,965.6
Losses	554.9	510.6	291.0
Net Interchange	-2,545.0	-1,100.7	419.4
% MW Installed Renewable Gen	20.9%	32.12%	46.63%

The transfer levels for the VIC-LA, Pacific DC Intertie (“PDCI”) and the IPP DC lines are shown in Table 1-3.

**Table 1-3
Transfer Levels**

	Heavy Summer (MW)	Heavy Spring (MW)	Light Winter Load (MW)
VIC-LA	2,864.8	1,710.8	3,202.1
Pacific DC Intertie (PDCI) ¹	3,100.5	3,098.7	-965.5
IPP DC Line	2,406.0	2,406.0	1,744.4

¹ Total PDCI shown.

² Reference Direction for DC flow is North – South

Task 2: Steady State Power Flow Study - Baseline

Leidos conducted simulations on the cases described in Section 1 above to evaluate the performance of the LADWP system and identify any possible violations. Simulations were run utilizing the NERC transmission planning criteria (TPL-001 through TPL-004) and LADWP Operating Bulletin OB-31 for voltage criteria, unit voltages schedules, and transformer taps with the models and contingencies described above. Single and double contingency analyses were performed, with double contingencies being based upon an initial list supplied by LADWP. In addition, an N-1-1 analysis was performed to determine those contingencies that cause violations to the system. A series of new base cases were created taking one of the N-1-1 elements out of service and applying any required mitigations. The full N-1 contingency list was then run with these “N-1 Base Cases” to determine the resulting violations. The N-1 Base Cases are detailed in Appendix A.

The Heavy Summer case had the highest frequency of violations while the Light Load case had the fewest – the Light Load case showed no thermal violations. In general, the same types of violations were seen in all three load cases. These violations are discussed below. The full set of results for each case and each contingency category are shown in Appendix B.

Contingency Lists

N-1 and N-2 Contingencies

Contingencies throughout the LADWP area were identified to use for the assessment to determine the response of the LADWP system. These events included a basic single contingency (“N-1”) scan throughout the model as a means to identify any major system concerns regarding flow or voltage that may impact the project area. The initial files were provided with a list of double contingency events (the “N-2” contingency list), referenced as “N-2 List.txt.” The full list of contingencies is provided as Appendix C.

N-1-1 Contingencies

A third set of contingencies were created to identify violations for a sequence of events with an initial loss of a system facility, followed by system adjustments, then followed by another loss of a single transmission system facility (“N-1-1”).

Leidos developed a methodology for determining the N-1-1 contingencies. This methodology is outlined in Appendix D.

Heavy Summer Case

Thermal Results

Single Contingency (N-1)

The N-1 contingency results for the Heavy Summer case showed several overloads. The most severe overloads appeared for the contingency of Adelanto to Toluca 500 kV circuit, overloading the Rinaldi to Valley #1 and #2 230 kV circuits up to 114 percent of their emergency rating, and the contingency of Tarzana to Olympic 230 kV circuit, overloading the Tarzana 230/138 kV transformer up to 118 percent of its emergency rating.

In order to mitigate the overload on the Rinaldi to Valley #1 and #2 230 kV circuit, Valley generation was dispatched up to 238 MW (pre-contingency generation level). To mitigate the overload on the Tarzana 230/138 kV transformer, Scattergood generation was increased by 166 MW.

**Table 2-1
Summer Single Contingency Thermal Highlights**

Impacted Facility	Contingency	Rating (MVA)	Flow (% of Rating)	Mitigation
RINALDI - VALLEY #1 230kV	Line ADELANTO 5 - TOLUCA 500.0 #1	719	114%	Increase Valley (238 MW) Generation. Be careful not to overload Valley-Toluca lines
RINALDI - VALLEY #2 230kV	Line ADELANTO 5 - TOLUCA 500.0 #1	719	114%	Increase Valley (238 MW) Generation. Be careful not to overload Valley-Toluca lines
TARZANA 230/138kV TRAN	Line TARZANA 2 - OLYMPC 230.0 #3	328	119%	Increase SG by 166 MW

For additional results please refer to Appendix B.

Double Contingency (N-2)

The N-2 contingency results for the Heavy Summer case also showed several overloads. The most severe of these were the contingency of Olympic to Tarzana 230 kV line with the Tarzana 230/138 kV transformer, overloading the reactors on the Hollywood to Fairfax 138 kV Circuits A and B to 141 percent of their continuous rating, and the contingency of the Rinaldi to Tarzana #1 and #2 230 kV circuits, overloading the Northridge to Tarzana 230 kV circuit up to 133 percent of its emergency rating.

**Table 2-2
Summer Double Contingency Thermal Highlights**

Impacted Facility	Contingency	Rating (MVA)	Flow (% of Rating)	Mitigation
HOLYWD1 - HOLYWDLD #1 138kV	TARZANA OLYMPC 230 LINE & TARZANA OLYMPCLD 138.00 LINES OUT	191	141%	Increase Scattergood (250 MW)
NRTHRDGE - TARZANA #1 230kV	RINALDI TARZANA 230 LINES OUT	797	133%	Increase Scattergood (314 MW)

In order to mitigate the overload of the Hollywood 138-kV A and B line reactors, Scattergood generation was increased by 250 MW. To mitigate the overload on Northridge to Tarzana 230 kV circuit, Scattergood generation was further increased to a total increase of 314 MW (additional generation above the base case).

For additional results please refer to Appendix B.

Transmission Outage, followed by Adjustments, followed by Another Outage (N-1-1)

Several overloads were seen for the N-1-1 contingency results for the Heavy Summer. One of the most severe overloads was seen on one Olympic 230/138 kV transformer (Bank E or F) for the N-1-1 loss of the other Olympic 230/138 kV transformer (Bank F or E, respectively) and the Tarzana to RS-K Junction 138 kV parallel lines (single circuit). For this contingency, the remaining in service Olympic 230/138-kV transformer is loaded to 143% of its emergency rating. Similar results were seen for each combination (pairing) of these three facilities. This seems to be an existing issue not related to the additional renewables based on inspection of the topology, equipment ratings and customer loads projected in the area.

**Table 2-3
Summer N-1-1 Contingency Thermal Highlights
Initial Contingency of Tarzana 230/138 kV Transformer**

Impacted Facility	Contingency	Rating (MVA)	Flow (% of Rating)	Mitigation
OLYMPCLD - OLYMPC #E 138kV	Tran OLYMPCLD 1 - OLYMPC 230.00 #F	400	143%	See discussion below. Requires additional generation, switching and potentially load shedding.
OLYMPCLD - OLYMPC #F 138kV	Tran OLYMPCLD 1 - OLYMPC 230.00 #E	400	142%	See discussion below. Requires additional generation, switching and potentially load shedding.

One possible mitigation for the Olympic E or F transformer overloads observed would be to dispatch Scattergood to around 745 MW and open both Fairfax to Olympic

Section 2

138 kV lines post-first contingency. Subsequently, if the second contingency occurs and the customer loads at the time are high (as projected in this peak model), load shedding at Olympic would then be required (35 MW as projected by the Heavy Summer model).

Another severe N-1-1 event was the loss of Toluca East to Hollywood “E” 230 kV circuit 1 and Toluca East to Hollywood 230 kV circuit 3 overloading the Hollywood to RS-H Junction section of the Toluca – Hollywood 138 kV circuit 1 to 120% of its emergency rating. Similar results were seen for other combinations of these three facilities.

Table 2-4
Summer N-1-1 Contingency Thermal Highlights
Initial Contingency of Toluca E. to Hollywood E. 230 kV Circuit 1

Impacted Facility	Contingency	Rating (MVA)	Flow (% of Rating)	Mitigation
HOLYWDL - RS-H JUNC #1 138kV	Line TOL E 2 - HOLYWD_E 230.0 #1	287	120%	Cannot be mitigated under Rating 2 without dropping load or reducing renewables

One possible mitigation for the Hollywood to RS-H Junction 138 kV line segment overload for loss of the Toluca East to Hollywood 230-kV circuits 1 and 3 or 230/138-kV transformers E and F would be to dispatch an additional 754 MW of Scattergood generation post first contingency. Careful adjustment of the Scattergood phase shifting transformer prior to the second contingency (-2.5 degrees was tested successfully) would reduce the amount of load that must be shed at Hollywood post-second contingency. If customer loads are high enough when the second contingency occurs, this load shedding would then be performed at 135 MW (with no PST movement) or 110 MW (with PST movement).

For additional results please refer to Appendix B.

Voltage Results – Heavy Summer

Single Contingency (N-1)

Voltage violations were consistently seen if the Q09 shunt capacitor is kept online during some specific contingencies around Barren Ridge. Additionally, single contingencies north of Barren Ridge are a known problem and often result in unacceptable voltages (if a solution can be obtained).

The contingency loss of Haynes #9 and Magnolia generation resulted in depressed voltages around St. Johns, River and Velasco 230-kV substations with consistent difficulty solving the powerflow case. In order to mitigate this issue an additional Haynes generator was dispatched on.

For additional results refer to Appendix B.

Double Contingency (N-2)

No major voltage violations were identified in the N-2 contingency evaluation.

Transmission Outage, followed by Adjustments, followed by Another Outage (N-1-1)

Voltage violations were consistently seen if the Q09 shunt capacitor is kept online during some specific contingencies around Barren Ridge.

For additional results refer to Appendix B.

Heavy Spring Case

Thermal Results

Single Contingency (N-1)

The N-1 contingency results for the Heavy Spring case also showed several overloads. The most severe overloads were observed on the St. John to Atwater 230-kV circuit 1, loaded to 128 percent of its emergency rating for the loss of the Velasco to Atwater 230 kV circuit 1, and the Tarzana 230/138-kV transformer Bank E, loaded to 111 percent of its emergency rating for the loss of the Tarzana to Olympic 230 kV circuit 3.

In order to mitigate the overload on the St. Johns to Atwater 230 kV circuit, Haynes generation was increased by 350 MW. To mitigate the overload on the Tarzana 230/138 kV transformer, Scattergood generation was increased by 180 MW in addition to the 350 MW of Haynes generation (in the pre-contingency powerflow case).

**Table 2-5
Spring Single Contingency Thermal Highlights**

Impacted Facility	Contingency	Rating (MVA)	Flow (% of Rating)	Mitigation
STJOHN - ATWATER #1 230kV	Line VELASCO 2 - ATWATER 230.0 #1	558	128%	Increase Haynes by 350 MW
TARZANA 230/138kV TRAN	Line TARZANA 2 - OLYMPC 230.0 #3	328	111%	Increase SG by 180 MW

For additional results refer to Appendix B.

Double Contingency (N-2)

The most severe double contingency violations appeared with the loss of the Olympic to Tarzana 230 kV circuit 3 with the Tarzana 230/138 kV transformer Bank E overloading the Hollywood – Fairfax circuits A and B line reactors to 126 percent of their continuous rating and the contingency of Rinaldi to Airway #1 and #2 230 kV

Section 2

circuits overloading the Toluca East to Atwater 230 kV circuit up to 130 percent of its emergency rating.

In order to mitigate the overload on the Hollywood 138-kV line reactors, Scattergood generation was increased by 180 MW. To mitigate the overload on the Toluca East to Atwater 230 kV line, Haynes generation was increased by 350 MW (additional to the Scattergood 180 MW).

Table 2-6
Spring Double Contingency Thermal Highlights

Impacted Facility	Contingency	Rating (MVA)	Flow (% of Rating)	Mitigation
TOL E - ATWATER #1 230kV	RINALDI AIRWAY 230 LINES OUT	797	129%	Increase Haynes by 350 MW
HOLYWD1 - HOLYWDLD #1 138kV	TARZANA OLYMPC 230 LINE & TARZANA OLYMPCLD 138.00 LINES OUT	191	126%	Increase SG by 180 MW

The contingency of the Barren Ridge to Haskell Canyon #2 and #3 230 kV circuits diverged during the steady-state simulations, and was analyzed further in post-transient and transient stability simulations to include RAS operation (an existing feature). Also, loss of the Adelanto to Rinaldi and Victorville to Rinaldi 500 kV circuits did not require additional generation support to converge. These events were also analyzed in post-transient and transient simulations to determine the severity of the event.

For additional results please refer to Appendix B.

Transmission Outage, followed by Adjustments, followed by Another Outage (N-1-1)

The N-1-1 contingency results for the Heavy Spring case showed several overloads. One of the most severe was for the N-1-1 loss of the Victorville to Century #2 287 kV and Velasco to Atwater 230 kV circuits, overloading the St. John to Atwater 230 kV circuit up to 143 percent of its emergency rating. Similar results were observed for the N-1-1 loss of the Victorville to Century #1 287 kV and Velasco to Atwater 230 kV circuits. In order to mitigate this issue, Haynes generation was increased by 460 MW post first contingency (pre-second contingency). It is important to mention that RMR was not determined based on N-1-1 or N-2 results.

Table 2-7
Spring N-1-1 Contingency Thermal Highlights
Initial Contingency of Victorville to Century 287 kV #1 or #2

Impacted Facility	Contingency	Rating (MVA)	Flow (% of Rating)	Mitigation
STJOHN - ATWATER #1 230kV	Line VELASCO 2 - ATWATER 230.0 #1	558	143%	Increase Haynes by 460 MW

For additional results please refer to Appendix B. N-1-1 not used for RMR.

Voltage Results – Heavy Spring

Single Contingency (N-1)

Voltage violations were consistently seen if the Q09 shunt capacitor is kept online during some specific contingencies around Barren Ridge.

Some contingencies such as loss of the Fairfax-Airport and Fairfax-Hollywood 138kV lines had difficulty solving. These required only an additional 40 MVAR of support, indicating the proposed additional generation for thermal flow mitigation would suffice. The RMR dispatch alleviates these violations.

For additional results please refer to Appendix B.

Double Contingency (N-2)

No major voltage violations were identified in the N-2 contingency evaluation.

Transmission Outage, followed by Adjustments, followed by Another Outage (N-1-1)

Voltage violations were consistently seen if the Q9 shunt capacitor is kept online during some specific contingencies around Barren Ridge. It is important to mention that RMR was not determined based on N-1-1 or N-2 results.

For additional results please refer to Appendix B.

Light Winter Load Case

Thermal Results

Single Contingency (N-1)

No thermal violations were identified in the N-1 contingency evaluation for the light load case.

Section 2

Double Contingency (N-2)

No thermal violations were identified in the N-2 contingency evaluation for the light load case.

Transmission Outage, followed by Adjustments, followed by Another Outage (N-1-1)

The N-1-1 contingency results for the Light Load case did not show much concern besides the N-1-1 of two the Sylmar 230/220 kV transformers. It was noted that for the loss of Sylmar 230/220 kV transformers F and G, the remaining transformer (Bank E) will be severely overloaded -- up to 138 percent of its emergency rating. In order to mitigate this issue, SCE generation (at Pastoria and Mandalay) was brought online post first contingency as has historically been a typical mitigation in operating procedures in the area. It is important to mention that RMR was not determined based on N-1-1 or N-2 results.

Table 2-8
Light Load N-1-1 Contingency Thermal Highlights
Initial Contingency of Sylmar to Sylmar S 230kV #G Transformer

Impacted Facility	Contingency	Rating (MVA)	Flow (% of Rating)	Mitigation
SYLMARLA - SYLMAR S #F 230kV	Tran SYLMARLA 2 - SYLMAR S 230.00 #E 0.00	800	138%	Max Pastoria Generation (SCE, 742MW) and one Mandalay (200 MW) and cut schedule with area 14. Based on previous experience with operating procedures in the area

For additional results please refer to Appendix B.

Voltage Results – Light Winter

Single Contingency (N-1)

Voltage violations were consistently seen if the Q9 shunt capacitor is kept online during some specific contingencies around Barren Ridge.

Some contingencies, such as Rinaldi to Valley and Rinaldi to Tarzana 230 kV circuits, had difficulty solving with base-case dispatch levels. These required additional generation dispatch at Haynes to obtain a solution. Only 18 MVAR of additional support was required from the perspective of the Adelanto 500-kV bus. The RMR dispatch alleviates these violations.

Also, Leidos discussed options regarding improvement of the Cottonwood- Barren Ridge 230-kV line with LADWP staff. The line is well above its surge impedance loading. Reconductoring would be a costly proposition. Dynamic reactive support devices on the line terminals, such as STATCOM's, could balance the line's voltage regulation, and series compensation is also a possibility due to the line's length.

However, series compensation would need to be carefully investigated due to the high likelihood of inducing sub-synchronous resonance with Owens Gorge generation.

For additional results please refer to Appendix B.

Double Contingency (N-2)

No major voltage violations were identified in the N-2 contingency evaluation. The contingency of the Barren Ridge to Haskell Canyon #2 and #3 230 kV lines diverged during the steady-state simulation. This contingency was simulated in post-transient and transient stability to allow credit for RAS operation.

Transmission Outage, followed by Adjustments, followed by Another Outage (N-1-1)

Voltage violations were consistently seen if the Q9 shunt capacitor is kept online during some specific contingencies around Barren Ridge.

Several contingencies resulted in low voltages at Barren Ridge. A reactive device would be recommended (SVC/SC/SVD/STATCOM) around +/- 75 MVAR to help the voltage and could even eliminate the RAS that requires tripping of the renewables. This was tested in the transient stability simulations.

**Table 2-9
Light Load N-1-1 Contingency Voltage Highlights
Initial Contingency of Castaic 12 to Haskell Canyon 230 kV Ckt. 1**

Impacted Facility	Contingency	Voltage (p.u.)	Voltage (kV)	Mitigation
BARRENRD 230kV	Base system (n-0)	0.971	223.2	Add reactive support at Barren Ridge
BARRENRD 230kV	PT230 - BARRENRD 230.0 #1	0.935	215.1	Add reactive support at Barren Ridge

For additional results please refer to Appendix B.

Task 3: Post-Transient Voltage Stability Study - Baseline

Voltage stability means that a power system is able to maintain acceptable voltages at all buses under normal operating conditions and after a contingency. The primary driver of voltage instability is the inability of the power system to support the demand for reactive power, which generally increases with power transfer through the system. Therefore, in a voltage stability analysis, the relationships between transmitted power (“P”), voltage (“V”), and reactive power (“Q”) are reviewed.

Curves plotting the power versus voltage (“PV curves”) or the voltage against the reactive power (“VQ curves”) are common tools used in steady-state analysis. This terminology is used throughout this report.

The post-transient voltage stability analysis was performed using the WECC Voltage Stability Criteria as outlined in Table 3-1. Due to the complex architecture of the LADWP system as a whole and the common usage of the MVAR margin evaluation methods in the West, V-Q evaluation was the focus of this Task.

Table 3-1
WSCC Voltage Stability Criteria

Performance Level	Disturbance		MW Margin (P-V Method)	MVAR Margin (V-Q Method)
	Initiated by Fault	No Fault DC Disturbance		
A	Any element such as: <ul style="list-style-type: none"> • One Generator • One Circuit • One Transformer • One Reactive Power Source One DC Monopole 		> 5%	Worst Case Scenario ¹
B	Bus Section		> 2.5%	50% of Margin Requirement in Level A
C	Any combination of two elements such as: <ul style="list-style-type: none"> • A Line and a Generator • A Line and a Reactive Power Source Two Generators • Two Circuits • Two Transformers • Two Reactive Power Sources DC Bipole 		> 2.5%	50% of Margin Requirement in Level A

**Table 3-1
WSCC Voltage Stability Criteria**

Performance Level	Disturbance Initiated by Fault or No Fault DC Disturbance	MW Margin (P-V Method)	MVAR Margin (V-Q Method)
D	Any combination of three or more elements such as: <ul style="list-style-type: none"> • Three or More Circuits on ROW • Entire Substation • Entire Plant Including Switchyard 	> 0	> 0

¹ The most reactive deficient bus must have adequate reactive power margin for the worst single contingency to satisfy either of the following conditions, whichever is worse: (i) a 5% increase beyond maximum forecasted loads, or (ii) a 5% increase beyond maximum allowable interface flows. The worst single contingency is the one that causes the largest decrease in the reactive power margin.

Contingency List

The contingencies used in this analysis were determined based on the LADWP 10-Year Transmission Assessment Report. This allows Leidos to quickly establish a performance baseline for common contingencies without waiting for completion of dynamic stability simulations. Future tasks for this Project will consider stability results and re-evaluate the contingency list. The contingencies are shown in Table 3-2.

**Table 3-2
Voltage Stability Contingency List**

Number	Contingency
VQ_1	Adelanto-Rinaldi 500kV Line
VQ_2	Adelanto - Toluca 500 kV Line
VQ_3	Adelanto - Victorville 500 kV Line
VQ_4	Lugo-Victorville 500 kV Line
VQ_5	Victorville-Rinaldi 500 kV Line
VQ_6	McCullgh-Victorville 500 kV Line
VQ_7	Mead – Victorville 287 kV Line
VQ_8	Cottonwood-Barren Ridge 230 kV with Remedial Action Scheme (RAS)
VQ_9	Rinaldi – Barren Ridge 230 kV
VQ_10	PDCI Bipole
VQ_11	IPP DC Bipole
VQ_12	Palo Verde-g2-OL-MA-RAS
VQ_13	Adelanto-Rinaldi and Victorville-Rinaldi 500kV Lines
VQ_14	McCullgh-Victorville 500 kV Lines 1 & 2
VQ_15	Victorville-Century 287 kV Lines 1 & 2

**Table 3-2
Voltage Stability Contingency List**

Number	Contingency
VQ_16	Rinaldi - Tarzana 230 kV Lines 1 & 2
VQ_17	Rinaldi-Glendale 230 kV Lines 1&2
VQ_18	Rinaldi-Valley 230 kV Lines 1 & 2
VQ_19	Toluca-Valley 230 kV Lines 1&2
VQ_20	Glendale-Atwater 230 kV Lines 1&2
VQ_21	Tarzana – Olympic 230kV and 138kV Lines
VQ_22	Velasco-Century 230kV Lines 1&2
VQ_23	Century - Wilmington 138 kV Lines 1&2
VQ_24	Gramercy – Fairfax 138 kV Lines 1 & 2
VQ_25	Century – Gramercy 138 kV Lines 1 & 2
VQ_26	Gramercy Tap1 & Tap2 138 kV Lines
VQ_27	Airport – Fairfax 138 kV Lines 1 & 2
VQ_28	Barren Ridge – Haskell 230kV Lines 2 & 3
VQ_29	Toluca – Hollywood Lines 1, 2 and 3
VQ_30	Rinaldi – Tarzana Lines 1 & 2 and Northridge – Tarzana Line 1
VQ_31	Rinaldi – Tarzana Lines 1 & 2 and Northridge – Tarzana Line 1 with RAS

The buses monitored during the Voltage Stability Analysis were chosen based on their voltage change (ΔV) during the Steady-State contingency simulations – those with the greatest change were considered to be the weakest buses and were monitored in this analysis. The bus and contingency combinations assessed are shown in Table 3-3.

**Table 3-3
Voltage Stability Bus and Contingency Combinations**

Contingency	Bus #	Bus Name	Bus kV
VQ_1	26075	WLMNTNLD	138
VQ_2	26075	WLMNTNLD	138
VQ_3	26075	WLMNTNLD	138
VQ_4	26075	WLMNTNLD	138
VQ_5	26075	WLMNTNLD	138
VQ_6	26075	WLMNTNLD	138
VQ_7	26266	VIC15-13	287
VQ_8	24729	INYO	230
VQ_10	26266	VIC15-13 ¹	287
VQ_11	26075	WLMNTNLD	138
VQ_12	24729	INYO	230
VQ_13	26075	WLMNTNLD	138

**Table 3-3
Voltage Stability Bus and Contingency Combinations**

Contingency	Bus #	Bus Name	Bus kV
VQ_14	26266	VIC15-13	287
VQ_15	26266	VIC15-13	287
VQ_16	26093	TARZANA	230
VQ_17	26075	WLMNTNLD	138
VQ_18	26102	VALLEY	138
VQ_19	26268	TOL E	230
VQ_20	26081	ATWATER	230
VQ_21	26083	HOLYWD1	138
VQ_22	26075	WLMNTNLD	138
VQ_23	26069	CNTURY	138
VQ_24	26076	FAIRFAX	138
VQ_25	26069	CNTURY	138
VQ_26	26260	HALLDALE-C	138
VQ_27	26076	FAIRFAX	138
VQ_28	26947	Q09TAP	230
VQ_29	26093	TARZANA ¹	230
VQ_30	26093	TARZANA ¹	230
VQ_31	26083	HOLYWD1	138

¹ Contingencies VQ_10, VQ_29 and VQ_30 diverged during both the steady state and post-transient simulations for the summer and spring cases. Therefore, the worst-case buses were assumed.

Heavy Summer Case

The N-1 contingencies listed in the LADWP 2012 10-Year Transmission Assessment Report were run with a five percent increment in load in order to determine the weakest bus for the worst contingency. Based on the results, the worst single contingency was the Adelanto to Toluca 500 kV line and the weakest bus was the Wilmington 138 kV¹ bus. The post-transient reactive power margin at the Wilmington 138 kV bus was found to be 256 MVAR for this contingency with a 5% load increment within LADWP.

¹ There are existing, known voltage issues in the Inyo/Barren Ridge area. These issues were evident during this analysis as the Inyo bus, with the loss of the Lugo to Victorville 500 kV line, had a margin of 91 MVAR in the summer case. The Lugo to Victorville line is approximately 200 miles away from the Inyo substation. Due to these known issues, it is believed that a PV analysis in this area would obtain more meaningful results and for this QV analysis, the results are assumed to meet the required margin for these buses. For the continuation of the study (specifically Task 5), for these contingencies around Inyo/Barron Ridge, a PV analysis will be performed.

Task 3: Post-Transient Voltage Stability Study - Baseline

Table 3-4
Voltage Stability – Summer – Worst Case Scenarios

Worst Single Contingency with 5% Increment in Load	Worst Bus	MVAR Margin
VQ_2 : Line ADELANTO 500.0 to TOLUCA 500.0 #1	WLMNTNLD 138.0	256

Subsequently, all contingencies in Table 3-2 were run and the reactive power margin at the worst bus for each contingency was compared to a 256 MVAR margin for N-1 contingencies and a 128 MVAR for N-2 contingencies. Table 3-5 shows the results of this analysis. Instances where reactive power margin was criteria was not met are highlighted in red.

Table 3-5
Voltage Stability – Summer – Results

Contingency	Worst bus	Required Margin	MVAR Margin
VQ_1 : Line ADELANTO 500.0 to RINALDI2 500.0 #1	WLMNTNLD 138.0	256	309
VQ_2 : Line ADELANTO 500.0 to TOLUCA 500.0 #1	WLMNTNLD 138.0	256	292
VQ_3 : Line ADELANTO 500.0 to VICTORVL 500.0 #1	WLMNTNLD 138.0	256	303
VQ_4 : Line LUGO 500.0 to VICTORVL 500.0 #1	WLMNTNLD 138.0	256	302
VQ_5 : Line VICTORVL 500.0 to RINALDI 500.0 #1	WLMNTNLD 138.0	256	282
VQ_6 : Line MCCULLGH 500.0 to VICTORVL 500.0 #1	WLMNTNLD 138.0	256	278
VQ_7 : Line MEAD 287.0 to VICTORVILLE 287.0 #1	WLMNTNLD 138.0	256	282
VQ_8 : Cottonwood-Barren Ridge 230 kV Line with RAS 8	WLMNTNLD 138.0 ²	(See Note 2)	136
VQ_11 : IPPDC-Bipole	WLMNTNLD 138.0	128	220
VQ_12 : 2 PV UNITS	WLMNTNLD 138.0	128	248
VQ_13 : ADELANTO RINALDI2 & VICTORVL RINALDI 500 Lines out	WLMNTNLD 138.0	128	202
VQ_14 : MCCULLOUGH VICTORVILLE 500 Lines out	VIC15-13 287.0	128	165
VQ_15 : VICTORVL CNTURY 1 and VICTORVL CNTURY2 287kV Lines out	VIC15-13 287.0	128	138
VQ_16 : RINALDI TARZANA 230 Lines out	WLMNTNLD 138.0	128	194
VQ_17 : RINALDI AIRWAY 230 Lines out	WLMNTNLD 138.0	128	207
VQ_18 : VALLEY RINALDI 230 Lines out	WLMNTNLD 138.0	128	188
VQ_19 : VALLEY TOLUCA 230 Lines out	WLMNTNLD 138.0	128	214
VQ_20 : GLENDALE ATWATER 230 Lines out	WLMNTNLD 138.0	128	206
VQ_21 : TARZANA OLYMPC 230 Line & TARZANA OLYMPCLD 138.00 Lines out	VALLEY 138.0	128	144
VQ_22 : Velasco-Century 230 Lines out	WLMNTNLD 138.0	128	129
VQ_23 : Century-Wilmington 138 Lines out	WLMNTNLD 138.0	128	210
VQ_24 : Fairfax-Gramercy 138 Lines out ¹	WLMNTNLD 138.0	128	50
VQ_25 : Century-Gramercy 138 Lines out ¹	WLMNTNLD 138.0	128	50

**Table 3-5
Voltage Stability – Summer – Results**

Contingency	Worst bus	Required Margin	MVAR Margin
VQ_26 : Gramercy-Tap #1 & Tap #2 (includes Harbor) 138 Lines out	WLMNTNLD 138.0	128	263
VQ_27 : Airport-Fairfax 138 Lines out	AIRPORT 138.0	128	145
VQ_28 : Barren Ridge-Haskell 230kV Lines out	INYO 230.0 ²	(See Note 2)	75
VQ_31 : RINALDI-TARZANA #1 & #2 230 KV Lines and NRTHRIDGE-TARZANA 230 KV Line with Load ¹	WLMNTNLD 138.0	128	119

¹ Contingencies VQ_24, VQ_25, and VQ_31 did not meet the VAR margin for the weakest bus.

² Due to the issues around Inyo and Barren Ridge, this result is assumed to meet the worst case scenario.

Based on the results of the simulation, contingencies VQ_24, VQ_25 and VQ_31 did not meet the VAR margin for the weakest buses. A new case was created (based on the steady state analysis results) including mitigations to remedy all N-1 or N-2 thermal overloads as previously submitted in the Task 2 report. The results show the mitigations recommended to resolve power flow problems were also sufficient to resolve the post-transient margin deficiencies for the VQ_24, VQ_25 and VQ_31 contingencies. Table 3-6 shows these results with power flow mitigations considered.

**Table 3-6
Voltage Stability – Summer – Results After Mitigations**

Contingency	Worst bus	Required Margin	MVAR Margin
VQ_24 : Fairfax-Gramercy 138 LINES OUT	WLMNTNLD 138.0	128	280
VQ_25 : Century-Gramercy 138 LINES OUT	WLMNTNLD 138.0	128	314
VQ_31 : RINALDI-TARZANA #1 & #2 230 KV Lines and NRTHRIDGE-TARZANA 230 KV Line with Load	WLMNTNLD 138.0	128	219

For additional results please refer to Appendix E.

Heavy Spring Case

The N-1 contingencies listed in the LADWP 2012 10-Year Transmission Assessment Report were run with a five percent increment in load in order to determine the weakest bus for the worst contingency. Based on the results, the worst single contingency was the Adelanto to Toluca 500 kV line and the weakest bus was the Wilmington 138 kV² bus. The margin at the Wilmington 138 kV bus was found to be 249 MVAR for this contingency with a 5% load increment within LADWP.

² There are existing, known voltage issues at the Inyo 230 kV and Q09 Tap buses. These issues were evident during this analysis as the Inyo bus, with the loss of the Adelanto to Toluca 500 kV line, had a margin of 109 MVAR in the

**Table 3-7
Voltage Stability – Spring – Worst Case Scenarios**

Worst Single Contingency with 5% Increment in Load	Worst Bus	MVAR Margin
VQ_2 : Line ADELANTO 500.0 to TOLUCA 500.0 #1	WLMNTNLD 138.0	249

Next, all contingencies were run to find buses with at least a 249 MVAR margin for N-1 contingencies and 124.5 MVAR for N-2 contingencies. Table 3-8 shows the results.

**Table 3-8
Voltage Stability – Spring – Results**

Contingency	Worst bus	Required Margin	MVAR Margin
VQ_1 : Line ADELANTO 500.0 to RINALDI2 500.0 #1	WLMNTNLD 138.0	249	290
VQ_2 : Line ADELANTO 500.0 to TOLUCA 500.0 #1	WLMNTNLD 138.0	249	269
VQ_3 : Line ADELANTO 500.0 to VICTORVL 500.0 #1	WLMNTNLD 138.0	249	296
VQ_4 : Line LUGO 500.0 to VICTORVL 500.0 #1	WLMNTNLD 138.0	249	268
VQ_5 : Line VICTORVL 500.0 to RINALDI 500.0 #1	WLMNTNLD 138.0	249	291
VQ_6 : Line MCCULLGH 500.0 to VICTORVL 500.0 #1	WLMNTNLD 138.0	249	305
VQ_7 : Line MEAD 287.0 to VICTORVILLE 287.0 #1	WLMNTNLD 138.0	249	293
VQ_8 : Cottonwood-Barren Ridge 230 kV Line with RAS 8 ¹	WLMNTNLD 138.0	(See Note 1)	251
VQ_11 : IPPDC-Bipole	WLMNTNLD 138.0	124.5	202
VQ_12 : 2 VQ Units	WLMNTNLD 138.0	124.5	189
VQ_13 : ADELANTO RINALDI2 & VICTORVL RINALDI 500 Lines out	VIC15-13 287.0	124.5	128
VQ_14 : MCCULLOUGH VICTORVILLE 500 Lines out	WLMNTNLD 138.0	124.5	198
VQ_15 : VICTORVL CNTURY 1 AND VICTORVL CNTURY2 287KV Lines out	VIC15-13 287.0	124.5	133
VQ_16 : RINALDI TARZANA 230 Lines out	WLMNTNLD 138.0	124.5	195
VQ_17 : RINALDI AIRWAY 230 Lines out	WLMNTNLD 138.0	124.5	177
VQ_18 : VALLEY RINALDI 230 Lines out	WLMNTNLD 138.0	124.5	187
VQ_19 : VALLEY TOLUCA 230 Lines out UT	WLMNTNLD 138.0	124.5	184
VQ_20 : GLENDALE ATWATER 230 Lines out	WLMNTNLD 138.0	124.5	176
VQ_21 : TARZANA OLYMPC 230 LINE & TARZANA OLYMPCLD 138.00 Lines out	WLMNTNLD 138.0	124.5	153
VQ_22 : Velasco-Centrury 230 Lines out	WLMNTNLD 138.0	124.5	133
VQ_23 : Century-Wilmington 138 Lines out	WLMNTNLD 138.0	124.5	196

spring case. The Adelanto to Toluca line is approximately 200 miles away from the Inyo substation. Due to these known issues, it is believed that a PV analysis in this area would obtain more meaningful results and for this QV analysis, the results are assumed to meet the required margin for these buses. For the continuation of the study (specifically Task 5), for these contingencies around Inyo/Barron Ridge, a PV analysis will be performed.

**Table 3-8
Voltage Stability – Spring – Results**

Contingency	Worst bus	Required Margin	MVAR Margin
VQ_24 : Fairfax-Gramercy 138 Lines out	WLMNTNLD 138.0	124.5	230
VQ_25 : Century-Gramercy 138 Lines out	WLMNTNLD 138.0	124.5	196
VQ_26 : Gramercy-Tap #1 & Tap #2 (includes harbor) 138 Lines out	WLMNTNLD 138.0	124.5	212
VQ_27 : Airport-Fairfax 138 Lines out	WLMNTNLD 138.0	124.5	212
VQ_28 : Barren Ridge-Haskell 230kV Lines out	INYO 230.0 ¹	(See Note 1)	75
VQ_31 : RINALDI-TARZANA #1 & #2 230 KV LINES and NRTHRIDGE-TARZANA 230 KV Line with Load	WLMNTNLD 138.0	124.5	154

¹ Due to the issues around Inyo and Barren Ridge, this result is assumed to meet the worst case scenario

All contingencies met the VAR margin requirement with the exception of the known issues at Inyo. These issues are assumed to be existing and not caused by the contingencies studies here.

Light Load Case

The N-1 contingencies listed in the LADWP 10-Year Transmission Assessment Report were run with a five percent increment in load in order to determine the weakest bus for the worst contingency. Based on the results, the worst single contingency was the Adelanto to Victorville 500 kV line and the weakest bus was the Wilmington 138 kV³ bus. The margin at the Wilmington 138 kV bus was found to be 216 MVAR for this contingency with a 5% load increment within LADWP.

**Table 3-9
Voltage Stability – Light Load – Worst Case Scenarios**

Worst Single Contingency with 5% Increment in Load	Worst Bus	MVAR Margin
VQ_3 : Line ADELANTO 500.0 to VICTORVL 500.0 #1	WLMNTNLD 138.0	216

Next, all contingencies were run to find buses with at least a 216 MVAR margin for N-1 contingencies and 108 MVAR for N-2 contingencies. Table 3-10 shows the results.

³ There are existing, known voltage issues at the Inyo 230 kV and Q09 Tap buses. These issues were evident during this analysis as the Inyo bus, with the loss of the Lugo to Victorville 500 kV line, had a margin of 73 MVAR in the light load case. The Lugo to Victorville line is approximately 200 miles away from the Inyo substation. Due to these known issues, it is believed that a PV analysis in this area would obtain more meaningful results and for this QV analysis, the results are assumed to meet the required margin for these buses. For the continuation of the study (specifically Task 5), for these contingencies around Inyo/Barron Ridge, a PV analysis will be performed.

Table 3-10
Voltage Stability – Light Load – Results

Contingency	Worst bus	Required Margin	MVAR Margin
VQ_1 : Line ADELANTO 500.0 to RINALDI2 500.0 #1	WLMNTNLD 138.0	216	274
VQ_2 : Line ADELANTO 500.0 to TOLUCA 500.0 #1	WLMNTNLD 138.0	216	288
VQ_3 : Line ADELANTO 500.0 to VICTORVL 500.0 #1	WLMNTNLD 138.0	216	308
VQ_4 : Line LUGO 500.0 to VICTORVL 500.0 #1	WLMNTNLD 138.0	216	297
VQ_5 : Line VICTORVL 500.0 to RINALDI 500.0 #1	WLMNTNLD 138.0	216	260
VQ_6 : Line MCCULLGH 500.0 to VICTORVL 500.0 #1	WLMNTNLD 138.0	216	303
VQ_7 : Line MEAD 287.0 to VICTORVILLE 287.0 #1	WLMNTNLD 138.0	216	305
VQ_8 : Cottonwood-Barren Ridge 230 kV Line with RAS 8 ¹	WLMNTNLD 138.0	(See Note 1)	314
VQ_11 : IPPDC-Bipole	WLMNTNLD 138.0	108	207
VQ_12 : 2 PV UNITS	WLMNTNLD 138.0	108	219
VQ_13 : ADELANTO RINALDI2 & VICTORVL RINALDI 500 Lines out	WLMNTNLD 138.0	108	238
VQ_14 : MCCULLOUGH VICTORVILLE 500 Lines out	WLMNTNLD 138.0	108	308
VQ_15 : VICTORVL CNTURY 1 AND VICTORVL CNTURY2 287kV Lines out	VIC15-13 287.0	108	134
VQ_16 : RINALDI TARZANA 230 Lines out	GRAMERC1 138.0	108	149
VQ_17 : RINALDI AIRWAY 230 Lines out	WLMNTNLD 138.0	108	254
VQ_18 : VALLEY RINALDI 230 Lines out	WLMNTNLD 138.0	108	199
VQ_19 : VALLEY TOLUCA 230 Lines out	WLMNTNLD 138.0	108	199
VQ_20 : GLENDALE ATWATER 230 Lines out	TARZANA 230.0	108	174
VQ_21 : TARZANA OLYMPC 230 LINE & TARZANA OLYMPCLD 138.00 Lines out	GRAMERC1 138.0	108	168
VQ_22 : Velasco-Century 230 Lines out	WLMNTNLD 138.0	108	157
VQ_23 : Century-Wilmington 138 Lines out	WLMNTNLD 138.0	108	145
VQ_24 : Fairfax-Gramercy 138 Lines out	WLMNTNLD 138.0	108	185
VQ_25 : Century-Gramercy 138 Lines out	WLMNTNLD 138.0	108	152
VQ_26 : Gramercy-Tap #1 & Tap #2 (includes harbor) 138 Lines out	WLMNTNLD 138.0	108	171
VQ_27 : Airport-Fairfax 138 Lines out	WLMNTNLD 138.0	108	203
VQ_28 : Barren Ridge-Haskell 230kV Lines out	INYO 230.0 ¹	(See Note 1)	59
VQ_31 : RINALDI-TARZANA #1 & #2 230 KV Lines and NRTHRIDGE-TARZANA 230 KV Line with Load	WLMNTNLD 138.0	108	253

¹ Due to the issues around Inyo and Barren Ridge, this result is assumed to meet the worst case scenario

All contingencies met the VAR margin requirement with the exception of the known issues at Inyo. These issues are assumed to be existing and not caused by the contingencies studies here.

Task 4: Dynamic Stability Study - Baseline

Dynamic stability refers to a power system's ability to return to a stable operating condition following a disturbance. Such disturbances are often caused by short circuits due to equipment failure, lightning or events of nature (wind and ice storms, fire, earthquakes etc). The system response is the result of the actions taken by the controllers on a wide array of generators and other devices distributed through the system. For the most part, dynamic stability simulations concern themselves with the ability of the power system bus voltage angles and machine rotor angles to stay in synchronism, and for system voltages to remain at supportable levels.

The dynamic stability analysis was performed using WECC's TPL-001-WECC-RBP-2.1 System Performance Regional Business Practices disturbance performance table of allowable effects on other systems. These criteria are outlined in Table 4-1 and further illustrated in Figure 4-1. NERC's TPL-001 through TPL-004 was referenced in conjunction with these criteria.

Table 4-1
WECC Disturbance Performance Criteria

NERC and WECC Categories	Outage Frequency Associated with the Performance Category (outage/year)	Transient Voltage Dip Standard	Minimum Transient Frequency Standard	Post Transient Voltage Deviation Standard (See Note 3)
A	Not Applicable	Nothing in addition to NERC.		
B	≥ 0.33	Not to exceed 25% at load buses or 30% at non-load buses. Not to exceed 20% for more than 20 cycles at load buses.	Not below 59.6 Hz for 6 cycles or more at a load bus.	Not to exceed 5% at any bus.
C	0.033 – 0.33	Not to exceed 30% at any bus. Not to exceed 20% for more than 40 cycles at load buses.	Not below 59.0 Hz for 6 cycles or more at a load bus.	Not to exceed 10% at any bus.
D	< 0.033	Nothing in addition to NERC.		

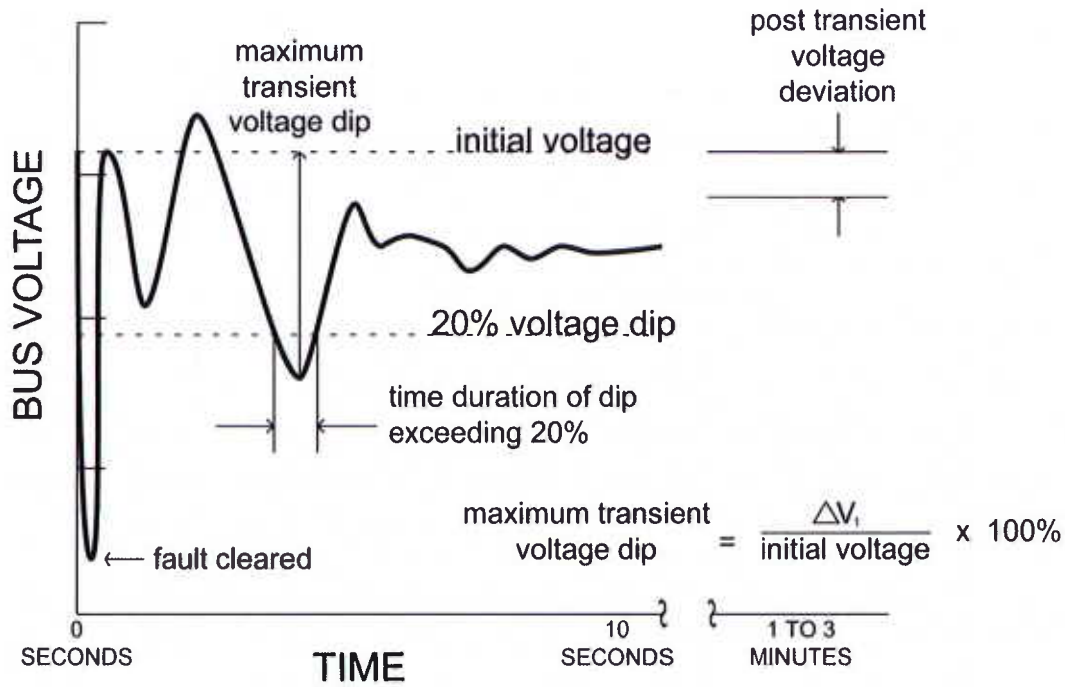

Figure 4-1: Voltage Performance Parameters

Contingency List

The contingencies used in this analysis were determined based on the LADWP 10-Year Transmission Assessment Report. The contingencies are shown in Table 4-2.

**Table 4-2
Dynamic Stability Contingency List**

Number	Contingency
SIM_1	Adelanto-Rinaldi 500kV Line
SIM_2	Adelanto - Toluca 500 kV Line
SIM_3	Adelanto - Victorville 500 kV Line
SIM_4	Lugo-Victorville 500 kV Line
SIM_5	Victorville-Rinaldi 500 kV Line
SIM_6	McCullgh-Victorville 500 kV Line
SIM_7	Mead – Victorville 287 kV Line
SIM_8	Cottonwood-Barren Ridge 230 kV with Remedial Action Scheme (RAS)
SIM_9	Rinaldi – Barren Ridge 230 kV
SIM_10	PDCI Bipole
SIM_11	IPP DC Bipole
SIM_12	Palo Verde-g2-OL-MA-RAS
SIM_13	Adelanto-Rinaldi and Victorville-Rinaldi 500kV Lines
SIM_14	McCullough-Victorville 500 kV Lines 1 & 2

Table 4-2
Dynamic Stability Contingency List

Number	Contingency
SIM_15	Victorville-Century 287 kV Lines 1 & 2
SIM_16	Rinaldi - Tarzana 230 kV Lines 1 & 2
SIM_17	Rinaldi-Glendale 230 kV Lines 1&2
SIM_18	Rinaldi-Valley 230 kV Lines 1 & 2
SIM_19	Toluca-Valley 230 kV Lines 1&2
SIM_20	Glendale-Atwater 230 kV Lines 1&2
SIM_21	Tarzana – Olympic 230kV and 138kV Lines
SIM_22	Velasco-Century 230kV Lines 1&2
SIM_23	Century - Wilmington 138 kV Lines 1&2
SIM_24	Gramercy – Fairfax 138 kV Lines 1 & 2
SIM_25	Century – Gramercy 138 kV Lines 1 & 2
SIM_26	Gramercy Tap1 & Tap2 138 kV Lines
SIM_27	Airport – Fairfax 138 kV Lines 1 & 2
SIM_28	Barren Ridge – Haskell 230kV Lines 2 & 3
SIM_29	Toluca – Hollywood Lines 1, 2 and 3
SIM_30	Rinaldi – Tarzana Lines 1 & 2 and Northridge – Tarzana Line 1
SIM_31	Rinaldi – Tarzana Lines 1 & 2 and Northridge – Tarzana Line 1 with RAS

Some contingencies, Sim_10, Sim_11 and Sim_12, did not stabilize. These contingencies require additional Remedial Action Schemes (“RAS”) outside of the LADWP BA. Also, these contingencies were simulated in the WECC base case (without LADWP renewable) with similar results – the system was unstable. This indicates that these contingency simulations are the pre-existing issues which have no direct impact to the scope of this study. Furthermore, tests conducted of various modified generation dispatches confirmed little impact from LADWP generation dispatch on system response. Thus, these contingencies should not be impacted by the MREPS and therefore, results for these contingencies are not reported.

Heavy Summer Case

Table 4-3 below summarizes the key performance characteristics observed in each simulation. The Gen Trip and RAS Operation columns refer to events that arise as a result of the simulation and are not a result of the sequence of events file – for example a generator that goes out of step but was not tripped intentionally. Any N-1 violations can be mitigated by RMR, otherwise the conditions listed in the table are post-event system conditions without any mitigation.

Table 4-3: Dynamic Stability Results – Heavy Summer

Cont. No.	Substation	Disturbance Description	Category	Stable	Gen Trip ¹	RAS Operation	Voltage Violations	Thermal Violations	Results	Remediation Actions
1	Rinaldi-2 500kV	3-Phase Fault at Rinaldi-2 500kV; 4 Cycle Clearing	B	Yes	No	No	No	No	Contingency (Loss of Adelanto-Rinaldi 500kV #1)	None
2	Adelanto 500kV	3-Phase Fault at Adelanto 500kV; 4 Cycle Clearing	B	Yes	No	No	No	Yes	Contingency (Loss of Adelanto-Toluca 500kV #1) - Valley-Rinaldi 230 kV #1 & #2 line overloads: 111%	The overload was mitigated in the Steady-State results by increasing Valley Generation
3	Victorville 500kV	3-Phase Fault at Victorville 500kV; 4 Cycle Clearing	B	Yes	No	No	No	No	Contingency (Loss of Adelanto-Victorville 500kV #1)	None
4	Lugo 500kV	3-Phase Fault at Lugo 500kV; 4 Cycle Clearing	B	Yes	No	No	No	No	Contingency (Loss of Lugo-Victorville 500kV #1)	None
5	Rinaldi-1 500kV	3-Phase Fault at Rinaldi-1 500kV; 4 Cycle Clearing	B	Yes	No	No	No	No	Contingency (Loss of Rinaldi-Victorville 500kV #1)	None
6	Victorville 500kV	3-Phase Fault at Victorville 500kV; 4 Cycle Clearing	B	Yes	No	No	No	No	Contingency (Loss of McCullough-Victorville 500kV #1)	None
7	Mead 287kV	3-Phase Fault at Mead 287kV; 4 Cycle Clearing	B	Yes	No	No	No	No	Contingency (Loss of Mead-Victorville 287kV #1)	None
8	Barren Ridge 230kV (RAS)	3-Phase Fault at Barren Ridge 230kV; 4 Cycle Clearing with RAS	B	Yes	No	Yes	No	Yes	Contingency (Loss of Cottonwood-Barren Ridge 230kV #1) Includes RAS Action: - Trips Owens and Q9 units - Open Inyo Tie	None
10	Loss of PDCI	Loss of PDCI Bipole with North-to-South Flow for Multi-Terminal DC Presentation	B	No	-	Yes	-	-	Contingency (Loss of PDCI Bipole) Simulation did not stabilize. Based on results, seems to be insufficient generation response in areas 30, 40 and 50.	This contingency should not be impacted by MREPS. The simulation was also run in the WECC base case and also did not stabilize.
11	Loss of IPPDC	Loss of IPP DC Bipole with North-to-South Flow	C	No	-	Yes	-	-	Contingency (Loss of IPP DC Bipole with North-to-South Flow) Simulation shows lack of generation response in Areas 62 and 65 (remote end of DC line)	This contingency should not be impacted by MREPS. The simulation was also run in the WECC base case and also did not stabilize.
12	Loss of Palo Verde Gen	Loss of Palo Verde Generators Units #1 & #2	C	No	-	Yes	-	-	Contingency (Loss of Palo Verde Generators Units #1 & #2) Simulation did not stabilize. Based on results, seems to be a lack of generation response around areas 14 and 18.	This contingency should not be impacted by MREPS. The simulation was also run in the WECC base case and also did not stabilize.

Table 4-3: Dynamic Stability Results – Heavy Summer

Cont. No.	Substation	Disturbance Description	Category	Stable	Gen Trip ¹	RAS Operation	Voltage Violations	Thermal Violations	Results	Remediation Actions
13	Rinaldi 500kV	3-Phase Fault at Rinaldi 500kV; 4 Cycle Clearing	C	Yes	No	No	No	No	Contingency (Loss of Adelanto-Rinaldi 500kV #1; Loss Victorville-Rinaldi 500kV #1)	None
14	Victorville 500kV	3-Phase Fault at Victorville 500kV; 4 Cycle Clearing	C	Yes	No	No	No	No	Contingency (Loss of McCullough-Victorville 500kV #1 & #2)	None
15	Victorville 287kV	3-Phase Fault at Victorville 287kV; 4 Cycle Clearing	C	Yes	No	No	No	No	Contingency (Loss of Victorville-Century 287kV #1 & 2)	None
16	Rinaldi 230kV	3-Phase Fault at Rinaldi 230kV; 4 Cycle Clearing	C	Yes	No	No	No	Yes	Contingency (Loss of Rinaldi-Tarzana 230kV #1 & #2) - NorthRidge-Tarzana 230 kV line overloads: 131%	The overload was mitigated in the Steady-State results by increasing ScatterGood Generation
17	Rinaldi 230kV	3-Phase Fault at Rinaldi 230kV; 4 Cycle Clearing	C	Yes	No	No	No	Yes	Contingency (Loss of Rinaldi-Glendale 230kV #1 & #2) - AtWater-Toluca E 230 kV line overloads: 107%	The overload was mitigated in the Steady-State results by increasing Haynes Generation
18	Rinaldi 230kV	3-Phase Fault at Rinaldi 230kV; 4 Cycle Clearing	C	Yes	No	No	No	No	Contingency (Loss of Rinaldi-Valley 230kV #1 & #2)	None
19	Toluca 230kV	3-Phase Fault at Toluca 230kV; 4 Cycle Clearing	C	Yes	No	No	No	No	Contingency (Loss of Toluca-Valley 230kV #1 & #2)	None
20	Glendale 230kV	3-Phase Fault at Glendale 230kV; 4 Cycle Clearing	C	Yes	No	No	No	No	Contingency (Loss of Glendale-Atwater 230kV #1 & #2)	None
21	Tarzana 230kV	3-Phase Fault at Tarzana 230kV; 4 Cycle Clearing	C	Yes	No	No	No	Yes	Contingency (Loss of Tarzana-Olympic 230kV #1 and 138kV #1) - Gramer-Fairfax 230 kV #1 & #2 lines overloads: 114% - Fairfax-Hollywood 230 kV #1 & #2 line overloads: 113%	The overload was mitigated in the Steady-State results by increasing Scattergood Generation
22	Velasco 230kV	3-Phase Fault at Velasco 230kV; 4 Cycle Clearing	C	Yes	No	No	No	No	Contingency (Loss of Velasco-Century 230kV #1 & #2)	None
23	Century 138kV	3-Phase Fault at Century 138kV; 4 Cycle Clearing	C	Yes	No	No	No	No	Contingency (Loss of Century-Wilmington 138kV #1 & #2)	None
24	Gramercy 138kV	3-Phase Fault at Gramercy 138kV; 4 Cycle Clearing	C	Yes	No	No	No	No	Contingency (Loss of Gramercy-Fairfax 138kV #1 & #2)	None
25	Century 138kV	3-Phase Fault at Century 138kV; 4 Cycle Clearing	C	Yes	No	No	No	No	Contingency (Loss of Century-Gramercy 138kV #1 & #2)	None
26	Gramercy 138kV	3-Phase Fault at Gramercy 138kV; 4 Cycle Clearing	C	Yes	No	No	No	No	Contingency (Loss of Gramercy-Tap1 138kV #1 & Gramercy-Tap2 138kV #1)	None

Section 4

Table 4-3: Dynamic Stability Results – Heavy Summer

Cont. No.	Substation	Disturbance Description	Category	Stable	Gen Trip ¹	RAS Operation	Voltage Violations	Thermal Violations	Results	Remediation Actions
27	Airport 138kV	3-Phase Fault at Airport 138kV; 4 Cycle Clearing	C	Yes	No	No	No	No	Contingency (Loss of Airport-Fairfax 138kV #1 & #2)	None
28	Barren Ridge 230kV	3-Phase Fault at Barren Ridge 230kV; 4 Cycle Clearing	C	Yes	No	Yes	No	No	Contingency (Loss of Barren Ridge-Haskell 230kV #1 & #2) Includes RAS Action: - Trips Beacon and Pinetree units	None
29	Toluca to Hollywood 138kV	Loss of Toluca-Hollywood Triple Towers	D	Yes	No	No	No	Yes	Contingency (Loss of Toluca-Hollywood 230kV #1 & #3, and 138kV #1) - Hollywood-Hollywood 138 kV #1 & #2 lines overloads: 111% - Gramer-Fairfax 230 kV #1 & #2 lines overloads: 103% - Fairfax-Olympic 138 kV #1 & #2 line overloads: 111%	Category D event
30	Northridge to Tarzana 230kV	Loss of Northridge-Tarzana Triple Towers	D	Yes	No	No	No	Yes	Contingency (Loss of Rinaldi-Tarzana 230kV #1 & #2; Loss of Northridge-Tarzana 230kV #1) - Major Overloads: (There are others, but not as severe) - Hollywood-Hollywood 138 kV #1 & #2 lines overloads: 237% - Gramer-Fairfax 230 kV #1 & #2 lines overloads: 202% - Fairfax-Hollywood 138kV #1 & #2 lines overloads: 198%	Category D event
31	Northridge to Tarzana 230kV	Loss of Northridge-Tarzana Triple Towers	D	Yes	No	Yes	No	Yes	Contingency (Loss of Rinaldi-Tarzana 230kV #1 & #2; Loss of Northridge-Tarzana 230kV #1; Load Shed at Canoga) - Major Overloads: (There are others, but not as severe) - Hollywood-Hollywood 138 kV #1 & #2 lines overloads: 187% - Gramer-Fairfax 230 kV #1 & #2 lines overloads: 157% - Fairfax-Hollywood 138kV #1 & #2 lines overloads: 128%	Category D event

1 Indicates if generation tripped due to instability (i.e., unintentional generation trip)

For plots, please see Appendix F.

Heavy Spring Case

Table 4-4 below summarizes the results of the Heavy Spring dynamic simulations. The Gen Trip and RAS Operation columns refer to events that arise as a result of the simulation and are not a result of the sequence of events file – for example a generator that goes out of step but was not tripped intentionally. Any N-1 violations can be mitigated by RMR, otherwise the conditions listed in the table are post-event system conditions without any mitigation.

Table 4-4: Dynamic Stability Results – Heavy Spring

Cont. No.	Substation	Disturbance Description	Category	Stable	Gen Trip ¹	RAS Operation	Voltage Violations	Thermal Violations	Results	Remediation Actions
1	Rinaldi-2 500kV	3-Phase Fault at Rinaldi-2 500kV; 4 Cycle Clearing	B	Yes	No	No	No	No	Contingency (Loss of Adelanto-Rinaldi 500kV #1)	None
2	Adelanto 500kV	3-Phase Fault at Adelanto 500kV; 4 Cycle Clearing	B	Yes	No	No	No	No	Contingency (Loss of Adelanto-Toluca 500kV #1)	None
3	Victorville 500kV	3-Phase Fault at Victorville 500kV; 4 Cycle Clearing	B	Yes	No	No	No	No	Contingency (Loss of Adelanto-Victorville 500kV #1)	None
4	Lugo 500kV	3-Phase Fault at Lugo 500kV; 4 Cycle Clearing	B	Yes	No	No	No	No	Contingency (Loss of Lugo-Victorville 500kV #1)	None
5	Rinaldi-1 500kV	3-Phase Fault at Rinaldi-1 500kV; 4 Cycle Clearing	B	Yes	No	No	No	No	Contingency (Loss of Rinaldi-Victorville 500kV #1)	None
6	Victorville 500kV	3-Phase Fault at Victorville 500kV; 4 Cycle Clearing	B	Yes	No	No	No	Yes	Contingency (Loss of McCullough-Victorville 500kV #1)	None
7	Mead 287kV	3-Phase Fault at Mead 287kV; 4 Cycle Clearing	B	Yes	No	No	No	No	Contingency (Loss of Mead-Victorville 287kV #1)	None
8	Barren Ridge 230kV (RAS)	3-Phase Fault at Barren Ridge 230kV; 4 Cycle Clearing with RAS	B	Yes	No	Yes	No	Yes	Contingency (Loss of Cottonwood-Barren Ridge 230kV #1) Includes RAS Action: - Trips Owens and Q9 units - Open Inyo Tie Overload violations at Q11 230/34.5 kV (101%) due to high voltage	The SVC at Barren Ridge that was recommended for simulation 28 would mitigate this issue as well.
10	Loss of PDCI	Loss of PDCI Bipole with North-South Flow for Multi-Terminal DC Presentation	B	No	-	Yes	-	-	Contingency (Loss of PDCI Bipole) Simulation did not stabilize. Based on results, seems to be a lack of generation response in areas 30, 40 and 50.	This contingency should not be impacted by MREPS. The simulation was also run in the WECC base case and also did not stabilize.

Section 4

Table 4-4: Dynamic Stability Results – Heavy Spring

Cont. No.	Substation	Disturbance Description	Category	Stable	Gen Trip ¹	RAS Operation	Voltage Violations	Thermal Violations	Results	Remediation Actions
11	Loss of IPPDC	Loss of IPP DC Bipole with North-to-South Flow	C	No	-	Yes	-	-	Contingency (Loss of IPP DC Bipole with North-to-South Flow) Simulation shows lack of generation response in Areas 62 and 65 (remote end of DC line)	This contingency should not be impacted by MREPS. The simulation was also run in the WECC base case and also did not stabilize.
12	Loss of Palo Verde Gen	Loss of Palo Verde Generators Units #1 & #2	C	No	-	Yes	-	-	Contingency (Loss of Palo Verde Generators Units #1 & #2) Simulation did not stabilize. Based on results, seems to be a lack of generation response in areas 14 and 18.	This contingency should not be impacted by MREPS. The simulation was also run in the WECC base case and also did not stabilize.
13	Rinaldi 500kV	3-Phase Fault at Rinaldi 500kV; 4 Cycle Clearing	C	Yes	No	No	No	No	Contingency (Loss of Adelanto-Rinaldi 500kV #1; Loss Victorville-Rinaldi 500kV #1)	None
14	Victorville 500kV	3-Phase Fault at Victorville 500kV; 4 Cycle Clearing	C	Yes	No	No	No	No	Contingency (Loss of McCullough-Victorville 500kV #1 & #2)	None
15	Victorville 287kV	3-Phase Fault at Victorville 287kV; 4 Cycle Clearing	C	Yes	No	No	No	Yes	Contingency (Loss of Victorville-Century 287kV #1 & 2) - St. John-Atwater 230 kV line overloads: 106.5%	The overload was mitigated in the Steady-State results by increasing Haynes Generation
16	Rinaldi 230kV	3-Phase Fault at Rinaldi 230kV; 4 Cycle Clearing	C	Yes	No	No	No	No	Contingency (Loss of Rinaldi-Tarzana 230kV #1 & #2)	None
17	Rinaldi 230kV	3-Phase Fault at Rinaldi 230kV; 4 Cycle Clearing	C	Yes	No	No	No	Yes	Contingency (Loss of Rinaldi-Glendale 230kV #1 & #2) - Toluca E-Atwater 230 kV line overloads: 126%	The overload was mitigated in the Steady-State results by increasing Haynes Generation
18	Rinaldi 230kV	3-Phase Fault at Rinaldi 230kV; 4 Cycle Clearing	C	Yes	No	No	No	No	Contingency (Loss of Rinaldi-Valley 230kV #1 & #2)	None
19	Toluca 230kV	3-Phase Fault at Toluca 230kV; 4 Cycle Clearing	C	Yes	No	No	No	No	Contingency (Loss of Toluca-Valley 230kV #1 & #2)	None
20	Glendale 230kV	3-Phase Fault at Glendale 230kV; 4 Cycle Clearing	C	Yes	No	No	No	Yes	Contingency (Loss of Glendale-Atwater 230kV #1 & #2) - Toluca E-Atwater 230 kV line overloads: 117%	The overload was mitigated in the Steady-State results by increasing Haynes Generation
21	Tarzana 230kV	3-Phase Fault at Tarzana 230kV; 4 Cycle Clearing	C	Yes	No	No	No	Yes	Contingency (Loss of Tarzana-Olympic 230kV #1 and 138kV #1) - Hollywood-HollywoodLD 138kV #1 & #2 lines overloads: 117%	The overload was mitigated in the Steady-State results by increasing Scattergood Generation

Table 4-4: Dynamic Stability Results – Heavy Spring

Cont. No.	Substation	Disturbance Description	Category	Stable	Gen Trip ¹	RAS Operation	Voltage Violations	Thermal Violations	Results	Remediation Actions
22	Velasco 230kV	3-Phase Fault at Velasco 230kV; 4 Cycle Clearing	C	Yes	No	No	No	No	Contingency (Loss of Velasco-Century 230kV #1 & #2)	None
23	Century 138kV	3-Phase Fault at Century 138kV; 4 Cycle Clearing	C	Yes	No	No	No	No	Contingency (Loss of Century-Wilmington 138kV #1 & #2)	None
24	Gramercy 138kV	3-Phase Fault at Gramercy 138kV; 4 Cycle Clearing	C	Yes	No	No	No	No	Contingency (Loss of Gramercy-Fairfax 138kV #1 & #2)	None
25	Century 138kV	3-Phase Fault at Century 138kV; 4 Cycle Clearing	C	Yes	No	No	No	No	Contingency (Loss of Century-Gramercy 138kV #1 & #2)	None
26	Gramercy 138kV	3-Phase Fault at Gramercy 138kV; 4 Cycle Clearing	C	Yes	No	No	No	No	Contingency (Loss of Gramercy-Tap1 138kV #1 & Gramercy-Tap2 138kV #1)	None
27	Airport 138kV	3-Phase Fault at Airport 138kV; 4 Cycle Clearing	C	Yes	No	No	No	No	Contingency (Loss of Airport-Fairfax 138kV #1 & #2)	None
28	Barren Ridge 230kV	3-Phase Fault at Barren Ridge 230kV; 4 Cycle Clearing	C	Yes	No	Yes	No	No	Contingency (Loss of Barren Ridge-Haskell 230kV #1 & #2) -RAS Should only Trip one Beacon unit	During Spring and winter is recommended to only trip one Beacon and an SVC should be install at Barren Ridge.
29	Toluca to Hollywood 138kV	Loss of Toluca-Hollywood Triple Towers	D	Yes	No	No	No	No	Contingency (Loss of Toluca-Hollywood 230kV #1 & #3, and 138kV #1)	Category D event
30	Northridge to Tarzana 230kV	Loss of Northridge-Tarzana Triple Towers	D	Yes	No	No	No	Yes	Contingency (Loss of Rinaldi-Tarzana 230kV #1 & #2; Loss of Northridge-Tarzana 230kV #1) - Major Overloads: (There are others, but not as severe) - Hollywood-Hollywood 138 kV #1 & #2 lines overloads: 163% - Gramer-Fairfax 230 kV #1 & #2 lines overloads: 120% - Fairfax-Hollywood 138kV #1 & #2 lines overloads: 136%	Category D event

Section 4

Table 4-4: Dynamic Stability Results – Heavy Spring

Cont. No.	Substation	Disturbance Description	Category	Stable	Gen Trip ¹	RAS Operation	Voltage Violations	Thermal Violations	Results	Remediation Actions
31	Northridge to Tarzana 230kV	Loss of Northridge-Tarzana Triple Towers	D	Yes	No	No	No	Yes	Contingency (Loss of Rinaldi-Tarzana 230kV #1 & #2; Loss of Northridge-Tarzana 230kV #1; Load Shed at Canoga) - Major Overloads: (There are others) - Hollywood-Hollywood 138 kV #1 & #2 lines overloads: 140% - Gramer-Fairfax 230 kV #1 & #2 lines overloads: 116% - Fairfax-Hollywood 138kV #1 & #2 lines overloads: 100%	Category D event

1 Indicates if generation tripped due to instability (i.e., unintentional generation trip)

For plots, please see Appendix F.

Light Load Case

Table 4-5 below summarizes the results of the Light Winter dynamic simulations. The Gen Trip and RAS Operation columns refer to events that arise as a result of the simulation and are not a result of the sequence of events file – for example a generator that goes out of step but was not tripped intentionally. Any N-1 violations can be mitigated by RMR, otherwise the conditions listed in the table are post-event system conditions without any mitigation.

Table 4-5: Dynamic Stability Results – Light Load

Cont. No.	Substation	Disturbance Description	Category	Stable	Gen Trip ¹	RAS Operation	Voltage Violations	Thermal Violations	Results	Remediation Actions
1	Rinaldi-2 500kV	3-Phase Fault at Rinaldi-2 500kV; 4 Cycle Clearing	B	Yes	No	No	No	No	Contingency (Loss of Adelanto-Rinaldi 500kV #1)	None
2	Adelanto 500kV	3-Phase Fault at Adelanto 500kV; 4 Cycle Clearing	B	Yes	No	No	No	Yes	Contingency (Loss of Adelanto-Toluca 500kV #1)	None
3	Victorville 500kV	3-Phase Fault at Victorville 500kV; 4 Cycle Clearing	B	Yes	No	No	No	No	Contingency (Loss of Adelanto-Victorville 500kV #1)	None

Table 4-5: Dynamic Stability Results – Light Load

Cont. No.	Substation	Disturbance Description	Category	Stable	Gen Trip ¹	RAS Operation	Voltage Violations	Thermal Violations	Results	Remediation Actions
4	Lugo 500kV	3-Phase Fault at Lugo 500kV; 4 Cycle Clearing	B	Yes	No	No	No	No	Contingency (Loss of Lugo-Victorville 500kV #1)	None
5	Rinaldi-1 500kV	3-Phase Fault at Rinaldi-1 500kV; 4 Cycle Clearing	B	Yes	No	No	No	No	Contingency (Loss of Rinaldi-Victorville 500kV #1)	None
6	Victorville 500kV	3-Phase Fault at Victorville 500kV; 4 Cycle Clearing	B	Yes	No	No	No	No	Contingency (Loss of McCullough-Victorville 500kV #1)	None
7	Mead 287kV	3-Phase Fault at Mead 287kV; 4 Cycle Clearing	B	Yes	No	No	No	No	Contingency (Loss of Mead-Victorville 287kV #1)	None
8	Barren Ridge 230kV (RAS)	3-Phase Fault at Barren Ridge 230kV; 4 Cycle Clearing with RAS	B	Yes	No	Yes	No	Yes	Contingency (Loss of Cottonwood-Barren Ridge 230kV #1) Includes RAS Action: - Trips Owens and Q9 units - Open Inyo Tie	None
10	Loss of PDCI	Loss of PDCI Bipole with South-North Flow for Multi-Terminal DC Presentation	B	No	-	Yes	-	-	Contingency (Loss of PDCI Bipole) Simulation did not stabilize. Based on results, seems to be a lack of generation response in areas 30, 40 and 50.	This contingency should not be impacted by MREPS. The simulation was also run in the WECC base case and also did not stabilize.
11	Loss of IPPDC	Loss of IPP DC Bipole with North-to-South Flow	C	No	-	Yes	-	-	Contingency (Loss of IPP DC Bipole with North-to-South Flow) Simulation shows lack of generation response in Areas 62 and 65 (remote end of DC line)	This contingency should not be impacted by MREPS. The simulation was also run in the WECC base case and also did not stabilize..
12	Loss of Palo Verde Gen	Loss of Palo Verde Generators Units #1 & #2	C	No	-	Yes	-	-	Contingency (Loss of Palo Verde Generators Units #1 & #2) Simulation did not stabilize. Based on results, seems to be a lack of generation response in areas 14 and 18.	This contingency should not be impacted by MREPS. The simulation was also run in the WECC base case and also did not stabilize.
13	Rinaldi 500kV	3-Phase Fault at Rinaldi 500kV; 4 Cycle Clearing	C	Yes	No	No	No	No	Contingency (Loss of Adelanto-Rinaldi 500kV #1; Loss Victorville-Rinaldi 500kV #1)	None
14	Victorville 500kV	3-Phase Fault at Victorville 500kV; 4 Cycle Clearing	C	Yes	No	No	No	No	Contingency (Loss of McCullough-Victorville 500kV #1 & #2)	None
15	Victorville 287kV	3-Phase Fault at Victorville 287kV; 4 Cycle Clearing	C	Yes	No	No	No	No	Contingency (Loss of Victorville-Century 287kV #1 & 2)	None
16	Rinaldi 230kV	3-Phase Fault at Rinaldi 230kV; 4 Cycle Clearing	C	Yes	No	No	No	No	Contingency (Loss of Rinaldi-Tarzana 230kV #1 & #2)	None

Section 4

Table 4-5: Dynamic Stability Results – Light Load

Cont. No.	Substation	Disturbance Description	Category	Stable	Gen Trip ¹	RAS Operation	Voltage Violations	Thermal Violations	Results	Remediation Actions
17	Rinaldi 230kV	3-Phase Fault at Rinaldi 230kV; 4 Cycle Clearing	C	Yes	No	No	No	No	Contingency (Loss of Rinaldi-Glendale 230kV #1 & #2)	None
18	Rinaldi 230kV	3-Phase Fault at Rinaldi 230kV; 4 Cycle Clearing	C	Yes	No	No	No	No	Contingency (Loss of Rinaldi-Valley 230kV #1 & #2)	None
19	Toluca 230kV	3-Phase Fault at Toluca 230kV; 4 Cycle Clearing	C	Yes	No	No	No	No	Contingency (Loss of Toluca-Valley 230kV #1 & #2)	None
20	Glendale 230kV	3-Phase Fault at Glendale 230kV; 4 Cycle Clearing	C	Yes	No	No	No	No	Contingency (Loss of Glendale-Atwater 230kV #1 & #2)	None
21	Tarzana 230kV	3-Phase Fault at Tarzana 230kV; 4 Cycle Clearing	C	Yes	No	No	No	No	Contingency (Loss of Tarzana-Olympic 230kV #1 and 138kV #1)	None
22	Velasco 230kV	3-Phase Fault at Velasco 230kV; 4 Cycle Clearing	C	Yes	No	No	No	No	Contingency (Loss of Velasco-Century 230kV #1 & #2)	None
23	Century 138kV	3-Phase Fault at Century 138kV; 4 Cycle Clearing	C	Yes	No	No	No	Yes	Contingency (Loss of Century-Wilmington 138kV #1 & #2)	None
24	Gramercy 138kV	3-Phase Fault at Gramercy 138kV; 4 Cycle Clearing	C	Yes	No	No	No	No	Contingency (Loss of Gramercy-Fairfax 138kV #1 & #2)	None
25	Century 138kV	3-Phase Fault at Century 138kV; 4 Cycle Clearing	C	Yes	No	No	No	No	Contingency (Loss of Century-Gramercy 138kV #1 & #2)	None
26	Gramercy 138kV	3-Phase Fault at Gramercy 138kV; 4 Cycle Clearing	C	Yes	No	No	No	No	Contingency (Loss of Gramercy-Tap1 138kV #1 & Gramercy-Tap2 138kV #1)	None
27	Airport 138kV	3-Phase Fault at Airport 138kV; 4 Cycle Clearing	C	Yes	No	No	No	Yes	Contingency (Loss of Airport-Fairfax 138kV #1 & #2)	None
28	Barren Ridge 230kV	3-Phase Fault at Barren Ridge 230kV; 4 Cycle Clearing	C	Yes	No	Yes	No	No	Contingency (Loss of Barren Ridge-Haskell 230kV #1 & #2) -RAS Should only Trip one Beacon unit	During Spring and Winter is recommended to only trip one Beacon MSU transformer and an SVC should be installed at Barren Ridge.
29	Toluca to Hollywood 138kV	Loss of Toluca-Hollywood Triple Towers	D	Yes	No	No	No	No	Contingency (Loss of Toluca-Hollywood 230kV #1 & #3, and 138kV #1)	Category D
30	Northridge to Tarzana 230kV	Loss of Northridge-Tarzana Triple Towers	D	Yes	No	No	No	No	Contingency (Loss of Rinaldi-Tarzana 230kV #1 & #2; Loss of Northridge-Tarzana 230kV #1) - Hollywood-Hollywood 138 kV #1 & #2 lines overloads: 112%	Category D

Table 4-5: Dynamic Stability Results – Light Load

Cont. No.	Substation	Disturbance Description	Category	Stable	Gen Trip ¹	RAS Operation	Voltage Violations	Thermal Violations	Results	Remediation Actions
31	Northridge to Tarzana 230kV	Loss of Northridge-Tarzana Triple Towers	D	Yes	No	No	No	Yes	Contingency (Loss of Rinaldi-Tarzana 230kV #1 & #2; Loss of Northridge-Tarzana 230kV #1; Load Shed at Canoga)	Category D

¹ Indicates if generation tripped due to instability (i.e., unintentional generation trip)

For plots, please see Appendix F.

During the dynamic stability analysis, solutions could not be found for the SIM_10, SIM_11 and SIM_12 contingencies. It has been determined that these contingencies would not impact MREPS.

For the spring and light load cases, Sim_28 (Barren Ridge to Haskell 230 kV Lines 2 and 3) showed severe violations in the LADWP area and the case was not stabilized. Violations began with oscillations of Owens Gorge units and generation connected to those, such as Cottonwood and Q09, spread to Castaic units and eventually led to general instability. Of the options tested, the best performance was found if only one of the two main step-up transformers is tripped at Beacon (half the capacity instead of 100 percent). The addition of an SVC at Barren Ridge damped out the remaining oscillations.

Tasks 5-7: Maximum Renewable Energy Penetration Study

Transmission System Stress Evaluation

Tasks 1 through 4 of this study focused on analyzing the LADWP transmission system as it is presently forecasted by LADWP. This is true with respect to planned projects and upgrades, forecasted load growth and growth of distributed generation and demand side management programs, generation additions and retirements, and select known renewable generation projects in the LADWP interconnection queue that were considered most likely to move forward. These cases provide some interesting insight into future operations of the LADWP system.

The study plan calls for incorporating additional renewable generation into the dispatch stack to find the limit of what the transmission system can reliably support. LADWP provided Leidos with additional renewable generation from its interconnection queue for the purposes of providing further stress. The additional renewables from the LADWP interconnection are proposed to be located along the Barren Ridge to Cottonwood to Inyo 230 kV path (“BRI Path”). LADWP also expects to receive requests in the vicinity of the eastern and north eastern 500 kV extremities of its system, and the immediate adjacent portions thereof which include some partial ownership. Leidos stressed the LADWP transmission system through the following process:

1. Add the proposed BRI Path renewable generation to each seasonal case, sinking that generation to the LADWP load and leaving the LADWP interchange with adjacent Balancing Authorities (“BAs”) alone (generation flows into the LA Basin and not to other Areas).
 - a. In order to achieve this, in-basin generation must be backed off. As was shown in the results of the Tasks 1 through 4 simulations, there are several system conditions that require in-basin generation to mitigate them. Therefore, Leidos first sought to assess which in-basin units would require reliability must-run (“RMR”) status.
 - b. Once RMR units are identified, improve the transmission system and reduce the amount of RMR generation through feasible projects, such as transmission line re-conductoring, substation re-configuration, and the installation of additional substation equipment such as transformers, reactors, SVC’s and the like. In accord with LADWP staff, the addition of new transmission circuits was not considered an option.
2. Once a practical limit has been reached with respect to removing generation from service and performing system upgrades, conduct powerflow, post-transient and dynamic stability simulations and assess system performance. Where necessary, recommend any additional upgrades that may be feasible and

add back in-basin generation where needed for post-transient or dynamic stability performance.

3. Conduct the same process on a set of seasonal cases with renewables interconnected at 500 kV to the east and northeast (“Eastern Renewables” or “East 500 kV” cases).
 - a. Due to the fact there is little cross-impact between renewables located in the BRI Path and East 500 kV areas, and
 - b. The amount of additional generation presently in the LADWP queue in the BR Path area was found to be approximately equal to the amount of in-basin generation LADWP could offset (interchange with traditional in-basin generation to ensure the renewable serves Basin load). As such, the LADWP system could not simultaneously support all the proposed BR Path renewables plus Eastern 500 kV renewables, and these cases were simulated separately. It was determinate to replace LADWP local units with renewables. If the East renewable is used instead of East import, the association between east renewable and east import should be 1 to 1. However, further dynamics studies will need to be done to determine the impact, if any, turning east units offline will have on the system
 - c. Locations for East 500 kV tests included El Dorado, Marketplace, and McCullough 500 kV substations in Nevada.
4. Create one set of East 500 kV cases which sinks the proposed renewables to the LA basin loads (offset with basin generation) and another set of cases that stresses the LADWP VIC-LA interface. Results will be presented showing both the capability of the internal LADWP system and the external adjacent transmission system as two separate quantities.
 - a. The VIC-LA stress cases were created by increasing East 500 kV renewables and decreasing the PDCI import in a process similar to LADWP’s system operating limits (“SOL”) methodology and transmission scheduling practices on the VIC-LA. In a base-case comparison, the VIC-LA was stressed by increasing import from Arizona in lieu of the Eastern renewables in combination with reducing the PDCI import.

Additional BRI Path Generation

LADWP provided the following queued renewable generation projects, shown in Table 5-1 below. These were added to the BRI Path MREPS stress cases in addition to the 1,210 MW of renewables from the Task 1 through 4 baseline cases. Generation and the associated collector system buses and step-up transformers were added from an EPC file. Leidos then reviewed the data for consistency with expected construction of PV facilities based on its experience and adjusted data as necessary.

**Table 5-1
BRI Path Queued MREPS Generation Additions**

Generator ID	Size (MW)	POI Approximate Location
Q17 PV	250.0	230-kV line to Barren Ridge
Q18 PV	100.0	Beacon PV 230-kV Substation
Q19 PV	250.0	Beacon PV 230-kV Substation
Q20 PV	140 (2 x 70)	Q09 Substation (North of Cottonwood 230-KV)

BRI Path MREPS Stress Cases

Leidos created three models in PSLF based on the Heavy Summer, Heavy Spring, and Light Winter 2020 cases from Tasks 1 through 4 in combination with the additional generation specified in Table 5-1. In the 2020 Heavy Summer peak, LADWP had 731 MW of in-basin reserve coupled with roughly 1,378 MW of operating renewable generation sources. In these conditions LADWP is relying heavily on traditional generation sources that are decoupled from the LA basin through HVDC connections and thus can provide reserve margin but cannot provide immediate fault response for local events. In-basin dispatched generation was operating at 887 MW in the summer, 144.5 MW in spring, and 121.7 MW in winter, the in-basin generation includes the swing bus (Castaic 1G), Magnolia, Olive and Glendale units that cannot be turned off. Magnolia, Olive and Glendale are not LADWP units. These totals do not consider units operating as synchronous condensers. Effectively, this amount of MW is the amount available to offset additional renewable generation without changing interchange schedules. This is considered a starting point prior to adding units for post-transient and dynamic stability purposes.

Minimum Reliability Must Run (RMR) – Proposed 2020 System

Since the analysis results of the Task 1 through 4 cases routinely showed violations that required generation for resolution, Leidos created a mitigated heavy summer case -- the majority of violations were summer violations or could be mitigated through the same generation changes in each case. The case in question was mitigated for all N-1 violations found. The results required a reasonable amount of additional generation in the LA basin. Table 5-2 shows the key generation and interchange amounts that were necessary for the case to accommodate the proposed additional 1,210 MW of renewable generation and avoid system performance issues.

**Table 5-2
LADWP Mitigated Heavy Summer 2020 Case
Characteristics**

LADWP Generation	Heavy Summer (MW)
On-line Capacity	5,483.8
Dispatched MW	4,605.0
Load	6,595.1

Table 5-2
LADWP Mitigated Heavy Summer 2020 Case
Characteristics

LADWP Generation	Heavy Summer (MW)
Losses	554.9
Net Interchange	-2,545.0

Table 5-3
LADWP Mitigated Heavy Summer 2020 RMR Generation

Generating Facility	Unit	HS Dispatch (MW)
Valley	7	100
Valley	8	138
Scattergood	4	214
Scattergood	5	100
Scattergood	2	180
Scattergood	1	52
Haynes	8/9/10 (CC2 x1)	480

Note that although the Owens Gorge generation provides a significant stabilizing effect to the BRI Path and is operating in each case, it is not listed as here for multiple reasons, including the type/nature of the generators and the system response associated with these units.

Basis and Justification for RMR by Site

1. Scattergood – The generation at Scattergood helps with a multitude of violations. Specifically, improving flow on the Tarzana to Olympic lines and transformers, and controlling flow on the Scattergood to Olympic line. Additionally, these units provide some relief for loading conditions at Hollywood.
2. Valley – The Valley generation is on-line because it is the best and most effective location to control and alleviate the overload violations on the Rinaldi to Valley 230 kV lines.
3. Haynes – Haynes generation is the most beneficial of all the stations, as it provides some degree of improvement to each of the thermal violations observed. In addition to helping with the issues addressed most directly by Scattergood and Valley generation (Hollywood loading conditions, Tarzana to Olympic and Scattergood line violations and Rinaldi to Valley line violations), Haynes also provides direct relief to the overload of the St. John to River 230 kV line for an outage of the Atwater to Velasco 230 kV line.

Leidos conducted a series of simulations testing the modified generation dispatch. Full results can be reviewed in Appendix G.

LADWP Internal Basin Transmission System Upgrades

Subsequent to establishing the limiting cases with no transmission network upgrades, Leidos sought to increase renewable penetration and reduce the RMR generation in the LA basin. This required that many of the N-1 overload conditions observed in Tasks 1 through 4 be addressed through upgrades, reconfiguration, and other adjustments. This section lists the items that were necessary to reduce RMR generation in the basin to a minimal level.

Issue: Toluca East to Hollywood 230 kV Circuits 1 and 3

Single contingency loss of one circuit overloads the second above rating 2 in heavy load conditions unless in-basin generation is operating. This is due to the lower thermal rating of the underground cable segment of the line. Segment 1 (overhead) is rated 761/796 MVA while segment 2 (cable) is rated 313/358 MVA. Leidos set the ratings in segment 2 to match segment 1, recognizing this would require a substantial cable.

Issue: Hollywood Bank E and F and 138 kV Line Reactor Loading

As a result of upgrading and updating the impedance on the Toluca East to Hollywood lines and reducing in-basin generation, 230/138 kV transformer Banks E and F at Hollywood take on a greater share of the 138 kV system load. Leidos increased the reactance of the 138 kV line inductors in the Hollywood 1 to Fairfax A and Hollywood 2 to Fairfax B circuits to mitigate this. It should be noted this solution requires care be taken not to overload the 138 kV lines out of Gramercy. Another valuable mitigation could be to increase the impedance of Hollywood-Fairfax 138 kV lines; however, this would need to be tested before making final decisions.

Issue: Tarzana to Olympic Line 3

This line overloads under peak load N-0 conditions as Scattergood and Haynes generation are reduced. This is due to the lower thermal rating of the underground cable segment of the line. Segment 1 (overhead) is rated 529/769 MVA while segment 2 (cable) is rated 382/436 MVA. Leidos set the ratings in segment 2 to match segment 1, recognizing this would require a substantial cable. However, this issue is a constant operational constraint that affects the generation status in the basin.

Issue: Tarzana to Olympic Line 1 (138 kV) and Tarzana Transformer Bank E

Once Tarzana and Olympic Line 3 is upgraded, Line 1, which is a parallel 138 kV line and transformer, becomes the constraint. In order to alleviate all violations in this area, Line 1 is recommended to be reconducted to 230 kV and a third 230/138 kV transformer is installed at Olympic.

Issue: Atwater to St. John 230 kV Circuit 1

With heavy load and low in-basin generation levels, particularly at Haynes, the Atwater to St. John 230 kV circuit overloads for a loss of the Atwater to Velasco

230 kV circuit. Re-routing the Atwater to Haynes 230 kV circuit through St. John resolves this issue and allows Haynes generation to be reduced further.

Issue: Rinaldi to Valley, Valley to Toluca, Rinaldi to Airway 1 and 2, Toluca East - Atwater 230 kV Lines

During heavy load and high PDCI import conditions, flow attempting to go from Rinaldi 230 kV to Toluca/Hollywood and the eastern 230 kV substations is constrained with multiple contingency and flow balancing issues. Valley generation and Haynes generation can alleviate, but in order to reduce the required generation levels at these stations, these lines must be upgraded. Leidos tested multiple line upgrade options and reconfigurations including multiple additional 500 kV interconnection options at Rinaldi, Toluca, and Valley, and ultimately concluded there is no good way of alleviating these line overloads without new line construction. This is primarily due to the heavy influence of the PDCI on the Rinaldi 230 kV bus. If new construction cannot be accommodated and line flow cannot be reduced, then line ratings must be increased. These lines were increased to 800 MVA normal/900 MVA emergency (effectively 1024 emergency at 15 minutes), and impedance was updated.

MREPS Stress Cases

Following upgrading the PSLF model cases with projects listed above, Leidos developed the study model cases used in the power flow, post transient, and transient analyses in this report. Table 5-4 below summarizes the cases developed. For each item three seasonal cases were prepared.

**Table 5-4
MREPS Stress Cases**

Case	Description
BRI Path Stress Cases	Additional Renewable generation added in Barren Ridge – Inyo path.
East 500 – El Dorado – LA Basin	Added roughly 800 MW of renewable generation at El Dorado, sunked to LA Basin
East 500 – Marketplace – LA Basin	Added roughly 800 MW of renewable generation at Marketplace, sunked to LA Basin
East 500 – McCullough – LA Basin	Added roughly 800 MW of renewable generation at McCullough, sunked to LA Basin
East 500 – VIC-LA Stress	Increase East renewables at all three sites and modify PDCI flow as necessary to reach the VIC-LA path SOL
East 500 – VIC-LA Stress – El Dorado	Increase East renewables at El Dorado and modify PDCI flow as necessary to reach the VIC-LA path SOL

The subsequent sections provide Key Data for each of the models.

BRI Path MREPS Cases – Key Data

Tables 5-5, 5-6 and 5-7 provide key data regarding the characteristics of the BRI Path MREPS cases after the upgrades above were completed. These upgrades effectively

Tasks 5-7: Maximum Renewable Energy Penetration Study

allowed most major LADWP units in the LA Basin to be dispatched off. Leidos assumed synchronous condenser operation at certain key units where voltage regulation was needed, understanding this capability may or may not exist today.

**Table 5-5
BRI Path MREPS Cases Generation**

Generating Station	Summer Pgen (MW)	Spring Pgen (MW)	Light Load Pgen (MW)
Beacon PV	500.0	500.0	500.0
Copper Mountain PV	250.0	250.0	250.0
Q09 PV	150.0	150.0	150.0
Q11 PV	60.0	60.0	60.0
Q17 PV	250.0	250.0	250.0
Q18 PV	100.0	100.0	100.0
Q19 PV	250.0	250.0	250.0
Q20 PV	140.0	140.0	140.0
Moapa Solar	250.0	250.0	250.0
Castaic	49	13.0	0.0
Haynes	335.0	0.0	0.0
Valley	0.0	0.0	0.0
Scattergood	0.0	0.0	0.0
Harbor	0.0	0.0	0.0
Owens Gorge	108.0	108.0	108.0
Total Additional Renewable Generation	740.0	740.0	740.0

**Table 5-6 -
LADWP System Characteristics – BRI Path MREPS Stress Cases**

LADWP Generation	Heavy Summer (MW)	Heavy Spring (MW)	Light Winter Load (MW)
On-line Capacity	5,672.20	5,235.20	5,085.20
Dispatched MW	4,948.10	4,325.00	4,471.80
Load	6,595.10	4,212.70	2,965.00
Losses	652.87	600.22	375.93
Net Interchange	-2,313.78	-500.00	1119.54
% MW Capacity Renewable	32.40%	50.85%	73.25%

Section 5

The interface levels for the VIC-LA, Pacific DC Intertie (“PDCI”) and the IPP DC lines are shown in Table 5-7.

**Table 5-7 –
Transfer/Path Flow – BRI Path MREPS Stress Cases**

Transfer/Path	Heavy Summer (MW)	Heavy Spring (MW)	Light Winter Load (MW)
VIC-LA	2,703.40	1,303.60	2,774.30
Pacific DC Intertie (PDCI) ¹	3,100.00	3,094.20	-965.50
IPP DC Line	2,406.00	2,405.95	1,744.35

¹ Total PDCI shown.

² Reference Direction for DC flow is North – South

LADWP indicated in the future it may be possible both Q09 Substation and Cottonwood would become full 230-kV substations or switching stations with circuit breakers and protection. As such, LADWP desired to test single contingency loss of each potential segment of what is today the 230-kV Inyo – Barren Ridge line. As shown in the figure below, the proposed future generation additions exacerbate the issues that center around the relatively long 230-kV line from Cottonwood to Barren Ridge.

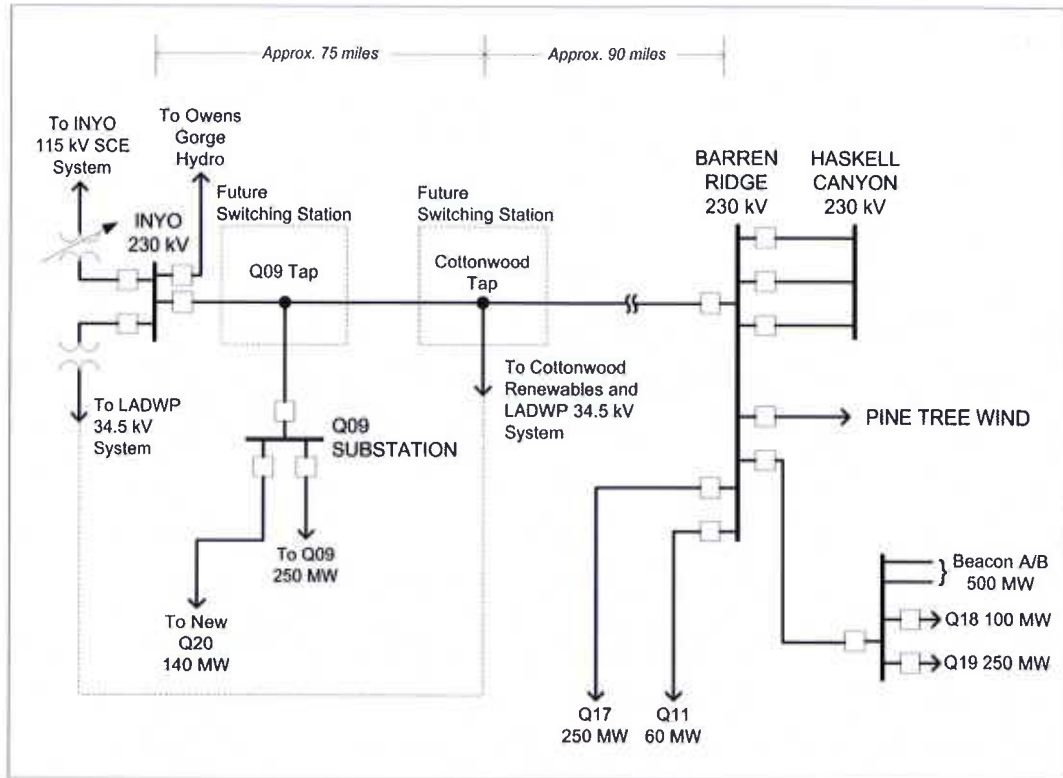

Figure 5-1 – Barren Ridge – Inyo Path Connection Detail

East 500-kV MREPS Cases – Key Data

As outlined in Table 5-4, Leidos developed alternatives to each seasonal case with 500-kV eastern interconnection locations for additional renewables at El Dorado, Marketplace, and McCullough, the combination of all three of these locations, and with sinking these renewables to the LA Basin as well as modifying interchange levels to stress the VIC-LA interface.

Simulation results for contingencies both in and around these substations along with the normal LADWP contingency list utilized in Section 2 showed little difference between the three potential locations, and little difference between importing renewable generation from these locations and importing generation from Arizona. Consequently, the bulk of the post-transient and dynamic stability simulations utilized a single case/location for each season rather than all three 500-kV substations. The Tables below summarize the characteristics of the LA Basin and VIC-LA Stress cases in selected key cases based on the small amount of differentiation between the three proposed locations.

Section 5

**Table 5-8-
LADWP System Characteristics – East 500-kV MREPS Stress Cases**

LADWP Generation	Heavy Summer (MW)	Heavy Spring (MW)	Light Winter Load (MW)
On-line Capacity	5,662.80	5,050.80	5,075.80
Dispatched MW	4,959.40	4,365.60	4,462.60
Load	6,595.10	4,212.65	2,965.63
Losses	564.77	498.63	267.45
Net Interchange	-2,212.60	-350.65	1219
% MW Capacity Renewable	32.41%	50.87%	73.27%

**Table 5-9 -
Transfer Levels– East 500-kV MREPS Stress Cases**

Transfer/Path	Heavy Summer (MW)	Heavy Spring (MW)	Light Winter Load (MW)
VIC-LA	3119.4	1692.6	3176.3
Pacific DC Intertie (PDCI) ¹	3100.2	3097.9	-965.5
IPP DC Line	2405.95	2405.95	1744.35

¹ Total PDCI shown.

² Reference Direction for DC flow is North – South

**Table 5-10 -
EAST 500 VIC-LA Stress Cases**

LADWP Generation	Heavy Summer (MW)	Heavy Spring (MW)	Light Winter Load (MW)
On-line Capacity	6,754.80	6,545.80	6,871.80
Dispatched MW	6,048.90	5,676.30	6,188.90
Load	6,595.10	4,212.65	2,965.63
Losses	422	297	393.24
Net Interchange	-992.97	1,161.99	2820.14
% MW Installed Renewable Gen	20.90%	82.79%	128.90%

**Table 5-11 -
Transfer Levels - EAST 500 VIC-LA Stress Cases**

Transfer/Path	Heavy Summer (MW)	Heavy Spring (MW)	Light Winter Load (MW)
VIC-LA	3,800.00	3,800.03	3,801.00
Pacific DC Intertie (PDCI) ¹	1,780.20	0	-1852.8
IPP DC Line	2,405.90	2,405.95	1,744.35

¹ Total PDCI shown.

² Reference Direction for DC flow is North – South

Highlighted Results

Leidos conducted power flow, post transient, and dynamic stability on each MREPS Stress case. The methodology and contingencies match those of the Tasks 1-4 baseline studies. Additionally, for the most part the primary internal system transmission violations are similar in the future MREPS cases to those in the Task 1-4 cases with the exception of higher ratings and flows in some cases. As such, this section presents the key highlighted violations and results.

A common thread in the MREPS Stress cases is that the upgrades internal to the LA Basin allow increased flow in certain areas such as Tarzana, Olympic, and Hollywood. Hollywood Transformers E and F overload for as single contingency loss of one another. This can be mitigated through adjustment of the size of the Hollywood reactors or upgrading the transformers.

While the proposed upgrades resolve all in-Basin N-1 contingency violations, Post-contingency overloads for N-2 and N-1-1 contingencies become more severe in certain instances. Refer to Appendices G, H and I for the full set of results.

Powerflow Simulations

BRI Path MREPS Cases

Much of the issue, analysis, and concern for these cases centers around the 230-kV path from Barren Ridge to Cottonwood, to Q09, to Inyo and Owens Gorge, as might be expected, similar to the Task 1-4 seed cases. Voltage regulation in the BRI Path continues to be an problem.

Due to the future considerations of building substations at the Q09 tap location and at Cottonwood, contingencies for loss of Inyo – Q09, Q09 – Cottonwood, and Q09 – Barren Ridge were also studied. These contingencies require RAS operation to solve in powerflow cases, and were studied in more detail in post-transient and dynamic stability.

The powerflow results for these cases indicate the need for voltage regulation on either side of the Cottonwood – Barren Ridge 230-kV line due to the large change in voltage drop on the line for changes in line flow which result from contingencies in the area. Loss of Q09 generation results in high voltages at Q09 and Inyo 230-kV.

East 500kV LA Basin Cases

These cases did not result in any new thermal violations. The Hollywood 230-138-kV transformer banks show up in the summer cases but do not in the Spring and Winter. Voltage violations in the Barren Ridge – Inyo path are present similar to the seed Task 1-4 cases. Loss of Q09 generation results in high voltages at Q09 and Inyo 230-kV.

East 500kV VIC-LA Stress Cases

These cases did not result in any new thermal violations. The Hollywood 230-138-kV transformer banks show up in the summer cases but do not in the Spring and Winter. Voltage violations in the Barren Ridge – Inyo path are present similar to the seed Task 1-4 cases. Loss of Q09 generation results in high voltages at Q09 and Inyo 230-kV. Additionally, some mild high voltage conditions exist at several 230-kV buses.

Post-Transient Simulations

Leidos conducted post-transient stability tests on the MREPS stress cases. The methodology used was as outlined in Section 3 of the report. Following the initial post-transient simulations conducted for Tasks 1-4, discussion with LADWP staff indicated the reactors at Wilmington 138-kV substation could be bypassed as a result of the Receiving Station C bypass projects. Leidos did so and the result was that the WilmingtonLD 138-kV bus was less often the weakest bus for QV analysis.

Leidos separated the Barren Ridge – Inyo path out and conducted Power vs Voltage simulations on this path rather than QV simulations due to its topology.

BRI Path MREPS Cases

No contingencies produced unstable results for QV, and MVAR margin requirements were met in each case. Barren Ridge – Inyo path buses were ignored in QV and assessed as part of the PV analysis.

Barren Ridge - Inyo buses have insufficient post-transient stability margin (less than 5%) for single contingencies including loss of one Barren Ridge – Haskell 230-kV line. The weakest buses are near Q09 tap location. Addition of a synchronous condenser of 60 MVAR at the Q09 location resolved this issue.

East 500kV LA Basin Cases

No contingencies produced unstable results for QV, and MVAR margin requirements were met in each case. Barren Ridge – Inyo path buses were ignored in QV and assessed as part of the PV analysis. In these cases the BRI path has Beacon and Q09 modeled. Post transient stability margin was satisfactory.

Dynamic Stability Simulations

Leidos conducted dynamic stability simulations utilizing the contingencies and events developed and described in Section 4 of this report. Contingencies were added for the MREPS stress cases where Leidos felt some additional analysis may be required. This largely consisted of additional test cases in and around the Barren Ridge – Inyo

Path as stability results in other portions of the system proved acceptable. The BRI path buses and equipment exhibited dynamic response issues in both the BRI Path cases and in the East 500-kV cases, when additional renewables were added elsewhere.

BRI Path MREPS Cases

Key simulations for this area include the loss of one Barren Ridge – Haskell 230-kV line, loss of the 230-kV line from Cottonwood – Barren Ridge with RAS operation, and loss of the two Barren Ridge – Haskell 230-kV lines with RAS operation. In addition, Leidos tested loss of the Beacon – Barren Ridge 230-kV tie line and conducted simulations with the Owens Gorge units out of service.

The worst system performance is in the light load cases (winter daytime weekend load). These cases exhibited multiple violations due to the high penetration of inverter based generation in this area, and due to the increase overall flow out of and through the Path. Issues noted are listed here:

1. Investigation is required to verify stability models for SCE and neighboring utilities.
2. Overall generation response from the nearby SCE area is not sufficient to withstand loss of Owens Gorge or loss of the Beacon Generator tie, unless the Edison tie is tripped high speed with RAS operation.
3. Project Queue inverters exhibit Q control noise due to low source strength – this represents a risk of inverter shut down and contributes to the area instability – increasing the time required for the Owens Gorge generator oscillations to damp out. These issues are evident for contingencies inside and outside of the BRI Path area.
4. Owens Gorge units show lightly damped oscillations in most in-basin simulations. This is largely due to the high impedance of the path between the gorge units the basin.

Critical Clearing Times – BRI Path cases

Leidos tested Critical Clearing times – the maximum length of time the system can withstand a fault at a given location without generators pulling out of step – at Rinaldi and Toluca 230-kV buses. Although each system bus has its own number, these buses were selected as indicators of overall system performance given the large number of connections and the lack of directly connected generation. The calculated critical clearing times were compared between the MREPS stress cases and the seed base cases from Task 4. These tests were conducted on the light winter cases with 3-phase fault, SLG fault should be evaluated as well.

**Table 5-12
BRI Path MREPS Case Critical Clearing Times**

Bus	Seed Case CCT	MREPS Case CCT
Rinaldi 230-kV	15 cycles	9 cycles
Toluca 230-kV	22 cycles	10 cycles

As can be seen in the table, the critical clearing times reduce significantly, which is an adverse impact. This means the LADWP system can withstand faults for a shorter duration when the traditional generation is offset with renewable generation. Although the dynamic events tested in this study utilized normal 4 cycle clearing times, it is expected that breaker failure and relay failure events would require longer clearing times, and the reductions shown in the table above are significant and are likely to be a real problem for LADWP. Increasing critical clearing time requires additional system inertia. In some cases changes to system topology can improve this as well.

Frequency Regulation Performance

As the penetration of renewables increases, two factors come in to play regarding frequency regulation. First, the amount of traditional synchronous generation available to regulate frequency is reduced as it is offset with renewables that cannot regulate frequency. Second, the renewables exhibit variable output which requires the traditional generation sources to ramp up and down to regulate the frequency. For the most part, due to the relatively large size of the renewable projects in the LADWP’s queue, and the variety of locations being considered, spatial diversity will largely keep the ramp rates from the renewable sources to a relatively reasonable size. The one area of concern would be the Beacon interconnection location, where much of the renewable solar PV is relatively co-located. This area represents the largest likely source of a solar PV induced ramp.

Leidos conducted ramp tests of solar irradiance at a practical top end of the type of ramp that would be statistically likely. Although the tests do not account for the performance of AGC and cannot be considered actual Area Control Error assessments, they do give a reasonable projection of the short-term performance of the LADWP traditional generation assets and the approximate amount of regulation response that should be available in the LADWP BA.

**Table 5-13
BRI Path MREPS Cases - Frequency Regulation**

Case/Season	Frequency Droop
Heavy Summer	13.6 mHz
Heavy Spring	9.7 mHz
Light Winter	29.4 mHz

The tests conducted consisted of a 250 MW ramp occurring over roughly 15 seconds. Given the tested cases included 1990 MW of solar PV, this is the largest ramp likely and is centered mostly around the Beacon/Barren Ridge area. This is based on Leidos' assessment of the available research (see discussion in Section 6).

East 500kV LA Basin Cases

Stability results indicated no major issues to address in these cases. Results showed post-event thermal overloads on select 138-kV and 230-kV lines which correlate to the results of powerflow simulations. These overloads were seen on Category C and D events. Similar to the results of the Seed base case dynamic simulations, Barren Ridge contingencies showed some violations and in Spring and Light Load it is recommended that the proposed RAS at Barren Ridge trip less generation.

Due to the increased flow on the upgraded transmission lines around Tarzana and Olympic, the exist RAS to shed load at Olympic following loss of the Rinaldi to Tarzana and Northridge to Tarzana 230-kV lines is no longer effective in the heavy summer cases and should be expanded. The RAS was still effective in the spring and light load cases.

Critical Clearing Times – East 500-kV LA Basin Cases

Leidos tested Critical Clearing times at Rinaldi and Toluca 230-kV buses. The calculated critical clearing times were compared between the MREPS stress cases and the seed base cases from Task 4. These tests were conducted on the light winter cases.

**Table 5-14
East 500-kV MREPS Case Critical Clearing Times**

Bus	Seed Case CCT	MREPS Case CCT
Rinaldi 230-kV	15 cycles	14 cycles
Toluca 230-kV	22 cycles	22 cycles

The significant difference between the results of the East 500-kV case and the BRI Path case is due to the stability issues that were observed on the BRI Path – locating less generation there improves the impact on CCT. That being said, the CCT test was not performed on 500-kV buses in the El Dorado valley – it is likely there is an impact there. This issue should be watched closely as renewable generation is added to the LADWP system.

Frequency Regulation Performance

Leidos tested solar irradiance ramps on the East 500-kV light winter cases using the same method as those tested on the BRI Path cases. Although the tests do not account for the performance of AGC and cannot be considered actual Area Control Error assessments, they do give a reasonable projection of the short-term performance of the LADWP traditional generation assets and the approximate amount of regulation response that should be available in the LADWP BA.

Table 5-15
East 500-kV MREPS Cases - Frequency Regulation

Case/Season	Frequency Droop
Heavy Summer	9.7 mHz
Heavy Spring	8.4 mHz
Light Winter	25.4 mHz

The tests conducted consisted of a 250MW ramp occurring over roughly 15 seconds. Given the tested cases included 1990 MW of solar PV, this is the largest ramp likely, as Leidos assumed the additional renewables located at the East 500-kV buses would not be from a single solar PV facility. This is based on Leidos' assessment of the available research (see discussion in Section 6).

Section 6

System Reliability Issues - Backdrop

This section will provide a backdrop to discuss some common issues associated with increased penetration of renewable energy resources. The issues will be grouped by the nature of the problem and common ways of analyzing and addressing the issue will be listed. The discussion will focus mostly on Solar PV based resources as these represent the bulk of the interconnections LADWP expects and is receiving. Many, but not all, of these issues are common to wind resources as well.

Issue #1 – Lack of Reserve Response

Renewable resources that are not combined with an energy storage device can only provide the power system with the amount of energy that is available in the renewable source, i.e. solar irradiance levels. Solar PV inverters can curtail output when irradiance is high – provide “down regulation” – but cannot provide more irradiance than what is available – no “up-regulation”. Consequently, for dynamic events where generation is lost or connectivity to load pockets is reduced and additional generation is desired, the renewable resources cannot assist. This issue often manifests itself as traditional generation is taken off-line, as these generators now run less efficiently at low output levels.

Commonly this issue can be tested by comparing the regulation response to a loss of generation event (what is the frequency droop that results?) with and without the proposed renewables.

Issue #2 – Variability

Due to the changes in the weather- sunny or cloudy conditions, wind gusts, etc, renewable resources introduce a non-controlled variability to the power system which traditional generation in operation must compensate for. This topic continues to be studied to be more thoroughly understood, and several research papers have been published which provide interesting insight into the magnitude and size of any “ramps” that a renewable resource might produce. Leidos has utilized data from “Empirical assessment of short-term variability from utility-scale solar PV plans” by R. van Haaren, M. Morjaria and V. Fthenakis to prepare estimates of the expected solar PV “ramps” from the prospective LADWP interconnection queue projects. The referenced paper provides cumulative probability distribution curves by overall plant size, given that spatial diversity allows larger plants to change more slowly in % of plant maximum capacity. The study shows that for most large plants, a practical top end for generated power in a single minute is roughly 50% of the size of the facility.

Table 6-1 – Frequency and Size of 1-Minute Ramps for LADWP Queue PV Gen

Queue ID	Max MW Output	Interconnection Facility	Est. 1-minute Ramp Rates (%)			Est. 1-minute Ramp Rates (MW) (Abs Value)			Minutes of Daylight/Year Expect to See this Δ		
			100% CPD	99.95% CPD	99.7% CPD	100% CPD	99.95% CPD	99.7% CPD	100% CPD	99.95% CPD	99.7% CPD
Q03	250	(DWP) Barren Ridge 230 kV Sw Station	13.93%	0.56%	0.16%	34.83	1.40	0.41	0	131	788
Q17	250	Barren Ridge - Rinaldi 230kV Line	13.93%	0.56%	0.16%	34.83	1.40	0.41	0	131	788
Q18	100	Beacon 230 kV Sw Station	40.91%	9.62%	4.75%	40.91	9.62	4.75	0	131	788
Q19	250	Beacon 230 kV Sw Station	13.93%	0.56%	0.16%	34.83	1.40	0.41	0	131	788
Q20	138	Owens Gorge - Rinaldi 230kV Line	11.14%	4.68%	2.00%	42.97	6.45	2.80	0	131	788

CPD: Cumulative Probability Distribution; Minutes of Daylight/Year assumed to be 262,800 (or half of a year)

Note the table shows, as an example, that Q18 can be expected to achieve a 40.9 MW ramp in a minute roughly 131 individual minutes a year. The larger the ramp, the less often it is probable to occur. Thus, utilizing a practical top end of 50% of project size in a minute represents an event closer to a cumulative probability of 99.97% (99.97% of all 1 minute ramps at the facility in the year will be of equal or lesser magnitude), which would roughly occur only 79 individual minutes out of the year.

This clearly bounds the expected daily regulating behavior of the LADWP generation on-line with the renewables. The effect of this variability can be tested by simulating solar irradiance ramps in PSLF to assess the frequency change in mHz that results.

Issue #3 – Control System Stability

Inverter based resources such as Solar PV require a certain amount of stiffness in the AC electrical source, not unlike HVDC systems. However, while HVDC requires source strength to drive thyristor commutation, IGBT and other full 4-quadrant type converters used in the PV inverters today require a stiff source to allow the inverter to detect and synchronize to the frequency of the connected system. In cases where the AC transmission system has relatively low short circuit strength compared to the size of the proposed PV inverter installation, the control system can exhibit unstable behavior in the reactive power control loop which can result in noise on the power system and potentially cause the inverters at the facility to shut down or to curtail real power output. Although PSLF models do not model the inverter control system to an extremely high level of detail, these models do typically contain enough representation of the relative speed of response in the reactive power/voltage control loops to exhibit noise and instability in the presence of weak source conditions. Often this can be hard to discern from noise that results from poor PSLF model representation, but running a few tests with different system conditions and different penetrations of inverter based resources in the PSLF dynamic simulations can often allow a conclusion to be drawn. ERCOT has studied strategies to handle voltage stability and grid strength challenges in its panhandle renewable energy zone. Their study indicates the use of synchronous condensers (along with other upgrades) will help in such situations.⁴

Issue #4 – Reduction of System Stiffness and Critical Clearing Times

As a result of the fact that inverter based resources do not provide significant fault current contribution and often displace traditional generation which does, large

⁴ ERCOT System Planning; *Panhandle Renewable Energy Zone (PREZ) Study Preliminary Results*; ERCOT Regional Planning Group Meeting; August 27, 2013.

penetrations of renewable resources can have the effect of weakening the system dynamic response. This can both add to the control system issues noted in Issue #3 and can cause Critical Clearing times to reduce throughout the system as a result of a decrease in overall spinning inertia. Some renewable generation vendors are working on this issue with respect to wind turbine response characteristics, but not for Solar PV. This can be tested by checking the critical clearing time a several key buses in the system to assess whether it is acceptable. This effect is even more severe if renewables are operating during light load conditions, with less generation and load in the system, and less available reserve.

Section 7

Summary and Recommendations

This study tested the capability of the LADWP electric system to support incorporation of renewable energy in two stages. The first stage required the addition of roughly 1210 MW of renewable generation to a projected set of 2020 cases. These cases were a Heavy Summer, Heavy Spring, and a Light Winter (Mid-day weekend) case and included load forecasts associated with those conditions as well as planned transmission and generation projects up to the 2020 timeframe. These were referred to as the “seed cases” and the 1210 MW constituted a set of projects from LADWP’s interconnection queue.

Leidos conducted power flow, dynamic stability, and post-transient stability analyses on the seed cases to assess the impact of the renewables. Following this evaluation, Leidos established mitigating actions for any system performance issues that were found, established Reliability Must Run generation associated with these cases, and subsequently sought to incorporate additional renewables, creating a set of “MREPS Stress cases” – one set for renewables in the Barren Ridge – Inyo path (BRI Path cases) and one set for renewables added to select 500-kV substations in the El Dorado Valley near Las Vegas.

The questions to be answered were as follows:

1. What is the maximum renewable penetration of the LADWP electric system without additional system upgrades (upgrades beyond those already planned for 2020)?
2. What is the maximum renewable energy penetration of the LADWP electric system with reasonable upgrades planned?

LADWP Basin Capability to Accept Renewables

The study results indicate that the planned 1210 MW of generation in the LADWP queue, combined with in-basin RMR, effectively constituted the maximum renewable energy that the system can accommodate without upgrades. The study also found several performance issues local to the Barren Ridge- Inyo 230-kV path – a known issue for LADWP staff. These issues are separate from the in-basin transmission constraints that drive the need for RMR generation.

Maximum Renewable Energy Penetration with Upgrades

Following completion of the upgrades described in Section 5 of this report, the amount of additional renewable generation that can be accommodated is essentially limited to the amount that LADWP can offset with internal traditional generation. In other words, increased transfer of energy from distant renewable is limited to a matching decrease in the amount of RMR. RMR is the minimum required in-basin thermal generation output. This is true regardless of the location of the proposed renewables,

with the BRI Path renewables requiring substantially more system upgrades due to the electrical weakness of that transmission path. The MREPS stress cases added 740 MW of additional renewables. The ability of the LADWP in-basin system to offset renewable generation in these cases was roughly 780 MW, making the total Maximum Renewable Energy Penetration 1990 MW if the proposed upgrades are completed.

It should also be noted that the amount of renewable energy that can be accommodated will be seasonally dependent – accommodating renewables in the MREPS Heavy Spring and Light Winter cases required changes in interchange. If East interchange MW is replaced by East renewable, the association between east renewable and east import should be 1 to 1. However, further dynamics studies will need to be done to determinate if turning east units offline will have any adverse effects to the system. Furthermore, the amount of renewable energy that can be accommodated would depend on load growth – if load forecasts are higher, more renewable energy can be accommodated, subject to the critical clearing time and frequency regulation issues discussed below.

Recommendations

The following discussion addresses specific issues Leidos observed in conducting these studies. It is broken up by case/scenario. All detailed results are attached to the report as Appendices.

2020 Seed Cases – Observations and Issues

For the most part, the analyses of the seed 2020 cases showed known transmission system issues. It should be noted that Leidos tested roughly 10 different major reconfiguration scenarios in an attempt to alleviate the congestion around Rinaldi – Valley – Toluca 230-kV lines. The goal was to find a small number of upgrades that would alleviate the congestion without requiring new transmission lines or upgrades to a large number of transmission lines.

1. No scenario tested successfully alleviated the congestion with a smaller set of projects than simply upgrading all the affected 230-kV lines. This is primarily driven by the angular dominance of the PDCI DC injection at Sylmar.
2. The amount of upgrades necessary to reduce the RMR generation down and allow the roughly 780 MW of additional renewable generation was significant compared to the amount of benefit achieved. Leidos understands many of these upgrades are planned as part of the LADWP 10 year transmission assessment, and so the additional 780 MW may not be the only benefit.
3. Leidos believes that a significant project may be needed that represents a paradigm shift (changing the basic fundamental interface characteristics of the basin system) if the system is to be pushed further than what the proposed transmission upgrades allow. This could be something such as upgrading the PDCI interconnection voltage to 500-kV or upgrade/replacement of the phase shifting transformers at Sylmar, for example.

Barren Ridge – Inyo 230-kV Path Renewables

As LADWP is aware, although many interconnection requests are being received in this vicinity, the BRI-Path portion of the system is very weak and is a challenging location to install renewable generation, from an electric transmission perspective. Due to the length of the Cottonwood – Barren Ridge 230-kV line, the available transmission capacity in this area is actually below the thermal capability of the transmission lines. The following recommendations apply to the 2020 seed cases, which do not include Q20, Q18 or Q19 generation.

1. In order to achieve both voltage regulation and improved short circuit strength, Leidos recommends installing a synchronous condenser at or near Cottonwood or Q09, and as renewable production increases, one may be needed at Barren Ridge as well.
2. The characteristics of the proposed RAS to accommodate the double circuit loss of two Barren Ridge – Haskell Canyon 230-kV lines should be reviewed. When renewable generation output is high and seasonal loads are low, the RAS trips too much generation too quickly and actually causes stability issues. Leidos did not slow it down to assess the dynamic voltage stability impact since composite load models were not developed yet, but if the primary goal is alleviating post-transient thermal violations, the RAS can and should be much slower. It presently trips generation at 4 cycles after the fault. This may be appropriate for Owens Gorge, but the renewables should be tripped in stages with longer delays to allow the system to appropriately measure the post-transient flow.

MREPS Stress Cases – Observations and Issues

Since the MREPS Stress Cases included the 230-kV transmission system upgrades proposed to reduce RMR, for the most part, thermal loading and steady state voltage were not issues for single contingencies. Leidos made the following observations:

1. Upgrading the 230-kV lines and select overloaded 138-kV lines caused a reduction in source impedance allowing the Hollywood and Olympic 138-kV sources to carry more of the Basin load relative to sources at Century, Scattergood, etc.. This will need to be carefully evaluated for modifications and additional projects to mitigate N-2 and N-1-1 violations that result from this, since mitigating these more severe contingencies was not considered in the MREPS Study.
2. Critical clearing times decrease and the frequency regulation band grows wider as additional renewables are added in place of traditional generation. This is more significant for the BRI Path renewables than for the East 500-kV renewables. As LADWP attempts to push for more renewables in the future, it is recommended additional synchronous condensing be investigated in the Basin (assess a minimum level) and that energy storage with frequency droop and short time overload capability be considered as a requirement for new renewable projects.

MREPS Stress - Barren Ridge – Inyo 230-kV Path Renewables

1. Study results using the 2020 models indicate a lack of SCE generation response (angular stability) for events in and around the BRI Path. This is specific to the generation close to the opposite side of the Inyo phase shifter. It is recommended this be investigated with SCE and that the stability models for SCE generators and LADWP renewable in the Owens Valley area need to be verified before any projects are proposed to address the rotor angle stability issue. The angular stability issue could be caused by inaccurate numerical models in the WECC stability data.
2. The amount of renewable generation proposed to be operating in the BRI Path if all queue projects move ahead represents a risk of inverter reactive power control instability. Short circuit source strength is concern, particularly under contingency conditions and when Owens Gorge generation is not operating. Leidos reduced the control instability in test simulations using two synchronous condensers, one located at Barren Ridge and one at Q09 tap.
3. Series compensation of the Cottonwood- Barren Ridge 230-kV line showed very positive results in stability and power flow simulations. However, this would require a separate feasibility evaluation to assess the impact on the Inyo phase shifter, Owens Gorge sub-synchronous resonance risk, and ferroresonance risks on nearby transformers.

Appendix 7

Maximum Distribution Renewable Penetration Study Scope of Work

This space is intentionally left blank

TASK SCOPE STATEMENT

Task Order No.

<u>Project:</u> Maximum Distribution Renewable Energy Penetration Study		Issued By: (Supervisor of User Group) [REDACTED]	Category & Subject: II – Transmission & Generation Services	
Project Phase:	Task Manager: (from User group) [REDACTED]	Contract Administrator: [REDACTED]	Consultant & Contract Agreement Number:	
User Group Name: System Study and Research	Function#:	Work Order#:	Task Order#: IRP 2-002-	
1. Project Description: (Summary of phase or multiple phases that are the subject of this task)				
<p>The Department is seeking services from full time technical Subject Matter Experts to fulfill the following tasks below:</p> <ul style="list-style-type: none"> • Task 1 - Quantify the maximum possible distributed PV solar penetration below which locally generated electric energy is integrated safely and reliably with no adverse impact to distribution facilities and above which significant improvements and/or distribution network upgrades are required for incremental DG output. The voltage levels of integration point are 4.8 kV and 34.5kV. • Task 2 - Quantify existing and potential impact of maximum possible PV solar integration on LADWP's distribution system operations, including but not limited to voltage and stability analysis, power quality, power factor analysis, harmonics, transients, distribution system protection, and distributed PV solar relaying requirements, possible risk of back feed power. • Task 3 - Provide safe and reliable mitigation solutions to all identified and/or potential adverse impacts delineated in Task 2 and 3 above as a result of deploying considerable amount of PV solar into LADWP's distribution system. The solution shall include but not limited to Energy Storage at Distribution level and customer side. • Task 4 - Propose a means and/or modeling tool to monitor 4.8kV feeders and 34.5kV circuits to ensure PV solar integration adequacy at no impact to existing customers. 				
2. Task Title: (one line Summary)				
To evaluate the impact of the maximum distributed PV solar into LADWP distribution system.				
3. Task Purpose and Objectives: (What is it? Business Need? Priority.)				
RPS Goal				
4. Location: (Premises where project will be located and potential impact on site infrastructure.)				
Los Angeles Department of Water Power 111 N. Hope St., Room 1246 Los Angeles, CA 90012 Also known as the John Ferraro Building (JFB)				
5. Task Scope of work: (Description of intermediate and end-products, deliverables, documents, etc.)				
The following scope of work is required from the approved consultant.				

TASK SCOPE STATEMENT

Task Order No.

Task 1.

Quantify the maximum possible distributed PV solar penetration below which locally generated electric energy is integrated safely and reliably with no adverse impact to distribution facilities and above which significant improvements and/or distribution network upgrades are required for incremental DG output. The voltage levels of integration point are 4.8 kV and 34.5kV.

Data Requirements

LADWP will provide locations where distributed energy is most likely going to occur in the Los Angeles Power System service area. It will include, but not limited to fifty (50) 4.8kV feeders and twenty (20) 34.5kV circuits. LADWP will provide load profile of respective circuits for the last three years. Where n and m represent the number of 4.8kV feeders and 34.5kV circuits, respectively, that will be selected to participate in this study.

Deliverables

1. Develop possible solar output profile at selected locations on a one-minute scale or better.
2. Report shall identify maximum possible distributed renewable energy generation capacity in MW injected into both 4.8kV and 34.5kV in three scenarios listed below.
 - (i) Low load with high PV output such as spring
 - (ii) Medium load with low PV output such as winter
 - (iii) High load with high PV Output such as summer
3. Report shall include the aggregate value at both Distribution and Receiving Stations of selected circuits stated above. Those aggregate values shall not exceed Station rating value unless it is only required to mitigate with minor upgrades.

Task 2.

Quantify existing and potential impact of maximum possible PV solar integration on LADWP's distribution system operations, including but not limited to voltage and stability analysis, power quality, power factor analysis, harmonics, transients, distribution system protection, and distributed PV solar relaying requirements, possible risk of back feed power.

Data Requirements

Outcome of Task 1

LADWP will provide one line diagrams of Distribution and Receiving Stations for selected area. This includes electrical characteristics from the FRAME software and geospatial models from ArcGIS.

Deliverables

1. Study Report identifying system reliability issues for each scenario defined in deliverable items of task 1.
2. List of issues with each specific location and electrical specifications.
3. Any distribution system models that were used to complete this task

Task 3.

Provide safe and reliable mitigation solutions to all identified and/or potential adverse impacts delineated in Task 2 and 3 above as a result of deploying considerable amount of PV solar into LADWP's distribution system. The solution shall include but not limited to Energy Storage at Distribution level and customer side.

Data Requirements

1. LADWP will provide reliability data as needed

Deliverables

1. List of options to mitigate all issues of all three scenarios as defined in task 1
2. List of mitigation shall include specification, electrical parameters, list of manufacturers, and hardware and software integrators
3. List of changes in the generation operation to mitigate issues listed in Task 3.

Task 4.

Propose a means and/or modeling tool to monitor 4.8kV feeders and 34.5kV circuits to ensure PV solar integration

TASK SCOPE STATEMENT

Task Order No.

adequacy at no impact to existing customers.

Data Requirements

LADWP will provide 4.8kV and 34.5kV for selected circuit diagrams

Deliverables

1. List of modeling tools to simulate and/or monitor selected 4.8kV and 34.5kV circuits
2. As a pricing option, bidders shall provide a cost to provide a 1-day training session in LADWP's office for using the recommended simulation tool.

Task Manager:

6. Overall Approach: (Provide details of how the task will be carried out. Use Appendix 1 , Work Order Breakdown. Attached detail schedule as Appendix 2.)

Task Manager:

The Consultant shall provide a softcopy and hard copy of all the above deliverables associated with Task 1 thru 4 in a single report, after LADWP approval of the proposed project schedule and plan for each task.

Consultant's Response:

7. Training Plan: (Provide details of how Consultant will carry out training for LADWP employees.)

Task Manager:

None

Consultant's Response:

8. Presentation at Completion of Task: (Provide details of how Consultant will present the

TASK SCOPE STATEMENT

Task Order No.

deliverable)

Task Manager:

The Consultant shall conduct a presentation at LADWP's JFB after completing each task.

Consultant's Response:

TASK SCOPE STATEMENT

Task Order No.

9. Contract Performance: Significant milestones/deliverables)

Due Date	Event/ Milestones	Site	Responsibility
Consultant's Response	<u>Task 1:</u>		Consultant's Response:
Consultant's Response:	<u>Task 2:</u>		Consultant's Response:
Consultant's Response:	<u>Task 3:</u>		Consultant's Response:
Consultant's Response:	<u>Task 4:</u>		Consultant's Response:
Consultant's Response:	<u>Task 5:</u>		Consultant's Response:

TASK SCOPE STATEMENT

Task Order No.

Consultant's Response:	<u>Task 6:</u>		Consultant's Response:
Consultant's Response:	<u>Task 7:</u>		Consultant's Response:

TASK SCOPE STATEMENT

Task Order No.

10. Related Tasks: (List any other tasks/ project activities which are impacted by this task.)

Task Manger:

11. Method of Compensation: (User: Choose "Fixed Cost" or "Time and Material. Consultant: List cost for each phase with deliverables. Attach cost estimate. Also include all expected travel expenses such as number of people, number of days, and locations.)

- Fixed Cost
 Time and Materials

Task Manager:

The Consultant shall provide the Names, Qualifications, Experience and Labor Categories of all personnel working on this task order. Any change of personnel during the course of the consultant's services shall be notified in writing to LADWP's Contract Administrator Catherine Cordero - Catherine.Cordero@ladwp.com. All personnel must be pre-approved before beginning work and payment is authorized.

The Consultant shall provide a list of the total estimated cost with a breakdown for each deliverable, including personnel and total hours expected for each sub-task

All Travel Authorities, including lodging with the dates & extension of contract days or hours and any purchases done to complete this task order shall be pre-approved by the Task Manager, Ms. Megan Yazdi. Any invoices submitted for payment without appropriate pre-approval shall be denied for payment.

The Consultant's invoice shall itemize the cost associated with each sub-task listed above. If the Consultant performs a combination of various sub-tasks, each invoice shall indicate the itemized cost for the individual subtasks. Any invoice that does not list itemized pricing as described above shall be denied for payment.

Consultant's Response:

TASK SCOPE STATEMENT

Task Order No.

12. Key Technical Assumptions: (Briefly describe any assumptions made about the project related to resources, scope, expectations, schedule, etc. Assumptions should be specific and measurable.)

Task Manager:

Consultant's Response:

13. Acceptance Criteria: (Provide details of the contract's acceptance criteria and a description of any significant risks associated with achieving timely acceptance with the plan.)

Task Manager:

Consultant's Response:

14. Pre-requisites to Consultant Personnel Performance:

(List required certification or experience, etc.)

Task Manager:

TASK SCOPE STATEMENT

Task Order No.

17. Special Requirement of Affected Organizations

1. INVOICE/PAYMENT MANAGEMENT	AFFECTED: YES <input type="checkbox"/> NO <input type="checkbox"/>
SPECIAL REQUIREMENTS Consultant shall submit monthly invoices in triplicate to: Catherine L. Cordero Contract Administrator Power System Planning & Development Division 111 N. Hope Street, Room 1250 Los Angeles, California 90012 Contact Information: Catherine.Cordero@ladwp.com (213) 367-8769	
2. QUALITY ASSURANCE	AFFECTED: YES <input type="checkbox"/> NO <input type="checkbox"/>
SPECIAL REQUIREMENTS	
3. PURCHASING/CONTRACT MANAGEMENT	AFFECTED: YES <input type="checkbox"/> NO <input type="checkbox"/>
SPECIAL REQUIREMENTS	
4. MANUFACTURING/PRODUCTION	AFFECTED: YES <input type="checkbox"/> NO <input type="checkbox"/>
SPECIAL REQUIREMENTS	
5. OTHER SERVICES AND MAINTENANCE	AFFECTED: YES <input type="checkbox"/> NO <input type="checkbox"/>
SPECIAL REQUIREMENTS	
6. FOREIGN EXCHANGE	AFFECTED: YES <input type="checkbox"/> NO <input type="checkbox"/>
SPECIAL REQUIREMENTS	
7. CONTRACT ADMINISTRATION	AFFECTED: YES <input type="checkbox"/> NO <input type="checkbox"/>
SPECIAL REQUIREMENTS	
8. OTHER AFFECTED ORGANIZATIONS	AFFECTED: YES <input type="checkbox"/> NO <input type="checkbox"/>
SPECIAL REQUIREMENTS Final review and approval of deliverables by LADWP before final payments.	

TASK SCOPE STATEMENT

Task Order No.

20. Commitment and Approval: <i>(Signed approval from all parties – Organization from LADWP and Consultants)</i>		
Organization	Name, Title, and Signature	Date
LADWP Power System Engineering Services Division - Major Projects Group	Mukhlesur Bhuiyan, Manager of Grid Planning and Development	
Consultant	Consultant	

TASK SCOPE STATEMENT

Task Order No.

Appendix 1: Work Order Breakdown Structure (WBS) (Create or attach a work breakdown structure for the contract.)

Task Manager:

Consultant's Response:

TASK SCOPE STATEMENT

Task Order No.

Appendix 2: Contract Performance: Schedule *(To attach print out for detail schedule from a Project Management Software, i.e Primavera)*

Task Manager:

Consultant's Response:

This space is intentionally left blank

Appendix 8

Maximum Generation Renewable Penetration Study Scope of Work

This space is intentionally left blank

TASK SCOPE STATEMENT

Requisition No.

Project: <i>(List the project name in which this task is part of)</i> Maximum Generation Renewable Energy Penetration Study (MGREPS)		Issued By: (Supervisor of User Group) [REDACTED]	Category & Subject: II- Transmission & Generation Services
Project Phase: Renewable Energy Penetration Study	Task Manager: (from User group) [REDACTED]	Contract Administrator: [REDACTED]	Consultant & Contract Agreement number:
User Group Name: System Study And Research	Function#:	Work Order & SPO#:	Task Order#: IRP 2-013-

1. Project Description: (Summary of phase or multiple phases that are the subject of this task)

The Department is seeking services from full time technical Subject Matter Experts to fulfill the following tasks below:

SUBTASK 1: RESOURCE ADEQUACY PLANNING

The time frame under SubTask 1 is from 2014 through 2034 (Period II)

Item 1.1: Evaluate Generation Dispatch Flexibility

Item 1.2: Propose Mitigation Solutions

Item 1.3: Provide Preliminary Report for Task 1

SUBTASK 2: GENERATION BALANCING REQUIREMENTS

The time frame under Task 2 is from 2014 through 2020 (Period I)

Item 2.1: Evaluate the Impact on Generation Balancing Requirements

Item 2.2: Perform a Sensitivity Analysis on Generation Balancing Requirements

Item 2.3: Analyze the Inertia and Frequency Response Requirements

Item 2.4: Conduct a Sensitivity Analysis on Inertia and Frequency Response Requirements

Item 2.5: Provide a Comprehensive Report

OPTIONAL SERVICES

Item 2.6: Provide Remedial Actions

Item 2.7: Provide Training

TASK SCOPE STATEMENT

Requisition No.

2. Task Title: (one line Summary)

Renewable Energy Penetration Study

3. Task Purpose and Objectives: (What is it? Business Need? Priority.)

The RPS Goal requires that 33 percent of LADWP's electricity retail sales be served by renewable energy resources by 2020. In line with this, the study objective is to analyze the impact of high penetration of VER and distributed solar PV generation on LADWP system balancing requirements including reserve requirements, ramp rate requirements, system reliability and operation requirements (system inertia and frequency response), and generation dispatch strategies.

4. Location: (Premises where project will be located and potential impact on site infrastructure.)

*Los Angeles Department of Water Power

111 N. Hope St., Room 1246

Los Angeles, CA 90012

*Also known as the John Ferraro Building

5. Task Scope of work: (Description of intermediate and end-products, deliverables, documents, etc.)

The following scope of work is required from the approved consultant:

SUBTASK 1: RESOURCE ADEQUACY PLANNING

The time frame under Subtask 1 is from 2014 through 2034 (Period II)

Item 1.1: Evaluate Generation Dispatch Flexibility

1. Determine the level of generation and the operational practices required in the generation fleet to balance the system with high penetration levels of VER.
2. Determine the required contingency reserves to account for the worst system event during time of high risk

Item 1.1: Deliverables

1. Identify the most challenging system operating conditions for all cases under each scenario as defined in the data requirement section including the expected system ramps and power plant limits, and the years in which such system conditions occur
2. Identify the most severe reserve requirements for all cases under each scenario including its size and the year in which said worst reserve requirements occur

Item 1.2: Propose Mitigation Solutions

1. Provide mitigation solutions for system conditions identified in Subtask 1.1 above including additional generation

Item 1.2: Deliverables

1. Provide mitigation measures, as applicable, including additional generation type, size, speed, location, and the years in which such mitigation solutions are needed for all cases under each scenario

Item 1.3: Provide Preliminary Report for Subtask 1

Item 1.3: Deliverables:

1. Provide a report describing the preliminary assessment under Subtask 1 no later than July 15, 2014.

SUBTASK 2: GENERATION BALANCING REQUIREMENTS

The time frame under Subtask 2 is from 2014 through 2020 (Period I)

Item 2.1: Evaluate the Impact on Generation Balancing Requirements

1. Regulation Capacity and Ramp Requirements
 - a) Determine the maximum upward and downward regulation capacity requirements
 - b) Determine the maximum upward and downward regulation ramp requirements
2. Load-Following Capacity and Ramp Requirements
 - a) Determine the maximum upward and downward load-following capacity requirements
 - b) Determine the maximum load-following up and down ramp requirements

Item 2.1: Deliverables

1. Regulation Capacity and Ramp Requirements
 - a) The Report shall provide hourly regulation capacity requirements for all cases under each scenario including maximum upward and downward regulation capacity requirements
 - b) The Report shall show the impact of the high penetration of VER and distributed solar PV generation on regulation capacity by comparing the requirements in all simulation cases
 - c) The Report shall indicate hourly regulation ramp requirements for all cases under each scenario including maximum regulation ramp (up and down) requirements
 - d) The Report shall demonstrate the impact high penetration of VER and distributed solar PV generation on regulation ramp requirements by comparing the ramp requirements in all simulation cases
2. Load-Following Capacity and Requirements
 - a) The Report shall provide hourly load-following capacity requirements for all cases under each scenario including maximum upward and downward load-following capacity requirements
 - b) The Report shall show the impact of the high penetration of VER and distributed solar PV generation on load-following capacity by comparing the requirements in all simulation cases
 - c) The Report shall indicate hourly load-following ramp requirements for all cases under each scenario including maximum load-following ramp (up and down) requirements
 - d) The Report shall demonstrate the impact high penetration of VER and distributed solar PV generation on load-following ramp requirements by comparing the ramp requirements in all simulation cases

TASK SCOPE STATEMENT

Requisition No.

Item 2.2: Perform a Sensitivity Analysis on Generation Balancing Requirements

1. Repeat Subtask 2.1 by taking into consideration the impact of randomness in the hourly day-ahead forecast errors for load and VER outputs by narrowing the look-ahead time horizon to 30 minutes and 15 minutes

Item 2.2: Deliverables

1. The Report shall compare and provide:
 - a) Regulation capacity requirements without and with forecast errors
 - b) Regulation ramp requirements without and with forecast errors
 - c) Load-Following capacity requirements without and with forecast errors
 - d) Load-Following ramp requirements without and with forecast errors

Item 2.3: Analyze the Inertia and Frequency Response Requirements

1. Determine the impact of a large loss of generation assets targeted by NERC Standard BAL-003 Frequency Response Bias based on:
 - a) Control Performance Standard (CPS1 and CPS2)
 - b) Reliability Base Control (RBC)
2. Determine additional regulation requirements on the system as a result of lower system inertia and having fewer committed generation units available to provide the needed governor response.
3. Propose mitigation solutions and/or requirements on VER generation to mitigate any effects observed under this task.

Item 2.3: Deliverables

1. Provide the minimum daily level of regulation indispensable to achieve acceptable reliability performance for all simulations based on NERC Standard BAL-003 Frequency Response Bias
 - a) CPS scores and ACE limits (CPS1 and CPS2)
 - b) Reliability Base Control (RBC) and ACE limits
2. Indicate the worst case frequency deviation and system recovery times for all simulations
3. Propose mitigation solutions to remedy system conditions observed in Item 2.3 (1) and (2)

TASK SCOPE STATEMENT

Requisition No.

Item 2.4: Conduct a Sensitivity Analysis on Inertia and Frequency Response Requirements

1. Perform a sensitivity analysis on Subtasks 2.2 and 2.3 by taking into account the impact of emerging source of flexibility such as Energy Storage System (ESS) on generation balancing requirements:

Table 1: Energy Storage Systems

Connection Level	Location	Storage Type	Estimated Capacity
Generation Level	Valley Thermal Power Plant (Units 6 & 7)	Gas Fired Generation and Thermal Energy Storage	50-MW
Transmission Level	Barren Ridge Area	BESS	30-MW
	Owens Valley	BESS	20-MW
Distribution Level	34.5kV or 4.8 kV	BESS	10-MW
Customer Level	Customer Side Permanent Load Shifting	Thermal Energy Storage (TES)	(1) 20-MW (2) 40-MW (3) 60-MW
	Demand Response	Thermal Energy Storage (TES)	30-MW
	Customer side	Electric Vehicle (EV)	(1) 20-MW (2) 50-MW

Item 2.4: Conduct a Sensitivity Analysis on Inertia and Frequency Response Requirements

- 1) Identify the most challenging hours for which regulation ramping requirements are the highest then determine the impact of a large loss of generation asset occurring half way through generation ramping process as illustrated in Figure 1 below where (t) represents the duration of the ramping from the initial capacity (MW_i) to the final or targeted capacity (MW_f).

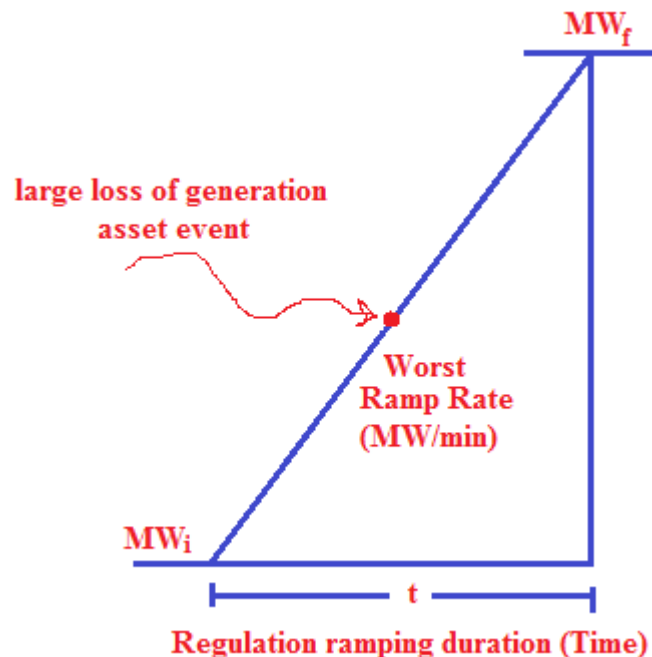

Figure 1: Large loss of generation illustration

Notes:

It should be assumed that all Energy Storage devices described in Table 1 above are remotely controlled by Energy Control Center (ECC) with a minimum total discharge duration is 2 hours and that only TES acting as a DR is remote controllable by ECC.

TES shall mean ice storage Thermal Energy System, an intelligent distributed thermal energy storage system that works in conjunction with commercial air conditioning systems specifically refrigerant based end customer air conditioning load. The system stores energy at night, when the electricity is less expensive, by converting liquid water into ice, and delivers that energy during peak hours to provide cooling to the building. It is fully integrated systems that provides metering-verification capabilities and dispatch/scheduling communication services.

TES typical operation: 1,200 to 1,400 hours/year use a Permanent Load Shifting (PLS)

Three scenarios shall be considered: 20-MW of TES embedded into LADWP's service territory (scenario 1), 40-MW of TES (scenario 2) and 60-MW of TES (scenario 3). All three scenarios are used as PLS.

TES typical demand response loads: 30 hours/year (remotely control by ECC). In this case only 20-MW of remote control TES is considered.

Gas Fired Generation + Thermal Energy Storage uses power at night (including wind or other resources in fleet)

TASK SCOPE STATEMENT

Requisition No.

to chill water that is then stored overnight for use the following day to chill the inlet air of the turbine below the temperature breaking point. This increases the capacity of peak time power by up to 20%, and provides quick regulation up/down capability (under ten minutes for full up/down) through simple temperature or pump adjustment (ideal for renewable integration).

BESS shall mean Battery Energy Storage System including but not limited to flow battery and Lithium Ion battery. EV shall mean Electric Vehicle representing a load into LADWP's service territory. However, EV load shall be used an incentivized load as a peak shaving or over generation mitigation. EV shall be included only in year 2020.

Item 2.4: Deliverables

- 1) The Report shall compare and/or provide:
 - a) CPS scores and ACE limits for worst case simulations with and without energy storage consideration
 - b) Reliability Based Control (RBC) and ACE limits for worst case simulations with and without energy storage consideration
 - c) The worst case frequency deviation and system recovery times with and without energy storage consideration
 - d) The year for which Energy Storage Systems should be considered and its recommended sizes or alternative resources
- 2) The report shall:
 - a) Provide Reliability Base Control and ACE limits for the event leading to the loss of large generation asset while proceeding with the identified worse regulation ramping rate requirements with and without energy storage consideration
 - b) Identify generation constraints and or limitations resulting from this contingency event
 - c) Propose cost effective mitigation solutions including, but not limited to ESS, alternative generation source (both size and speed), and curtailment.

Item 2.5: Provide a Comprehensive Report

Item 2.5: Deliverables

- 1) Provide one soft and 5 hard copies of the written report describing all findings and simulation results including recommendations and comments for all analysis performed under Task 2. The report shall be comprehensive and clear.

OPTIONAL SERVICES

Item 2.6: Provide Remedial Actions

As part of the report, determine methods to enhance planning and operations to accommodate high penetration levels including, but not limited to:

- a) *Generation dispatch strategy*
- b) *Reliability planning tools*
 - *Load-following Requirement Tool*
 - *Regulation Prediction Tool*

- *VER Forecasting*
- c) *Requirements on VER generating facilities*

Item 2.6: Deliverables - cont'd

- 1) *The Report shall provide:*
 - a) *Mitigation measures for any adverse conditions identified throughout the study that are deemed significant*
 - b) *Generation dispatch strategy to accommodate high VER and PV solar integration*
 - c) *Modeling tool to assist ECC with day-ahead and short-term planning with capability of predicting and displaying in real time load-following capacity and ramping requirements that results from uncertainties in load and VER generation forecasts*
 - d) *Modeling tool to assist ECC with day-ahead and short-term planning with capability of estimating upward and downward regulation requirements in terms of capacity, ramp rate, and ramp duration for each operation hour and for the next operating day.*
 - e) *Modeling tool to assist ECC with Next Hours Forecast and Next Day Forecast (see notes below) for short-term planning purposes to improve power system operations and reliability*
 - f) *Interconnection requirements that may be required on VER generating facilities to mitigate against frequency response deviations as applicable.*

Notes:

Next Hours Forecast: This is a short-term forecast that provides fine resolution for the next hours. This will be used as next-hour planning as well as input for operating strategies or mitigation plans and may be updated hourly or more frequently as new data becomes available. The value for this forecast, and the measure of its accuracy, is its ability to anticipate changes in VER and to allow system operators to identify and activate any additional reserves needed to maintain system reliability.

Next Day Forecast: This is a day-ahead forecast that provides hourly VER forecast for the next five (5) consecutive days and updated when major forecast products become available (every 6-12 hours). This forecast will be used in unit commitment process as well as identifying additional reserve needed to maintain system reliability that is cost effective.

Item 2.7: Provide Training

Provide training for modeling tools identified in Subtask 2.6

Item 2.7 Deliverables:

Provide an on-site training of recommended actions under Subtask 2.6

TASK SCOPE STATEMENT

Requisition No.

Duration of Work

These services shall commence immediately upon execution of the contract and shall terminate no later than December 31, 2014.

DATA REQUIREMENTS

The following data requirements provided by LADWP or any other appropriate means should be used to assess study requirements under each task as applicable.

Load Data

- Actual Loads in 1-minute resolution or better

VER and Distributed Solar PV Generation

- All existing and anticipated VER that will be transmitted into LADWP system including location, size, and commercial operation dates (COD).
- VER and distributed PV generation should be considered with 1-minute resolution or better
- Existing and projected aggregate sum of Feed-In-Tariff (FIT) generation
- Existing and projected aggregate Residential and building PV solar generation

Studies Results

- MTREPS report
- MDREPS report (if available)

Conventional Generation

- All available information on existing Thermal and Hydroelectric Generating Units including (capacity, ramping capability, COD, AGC response, performance and output profile data, modeling tool, etc.) For LMS100's, include time to turn on, time to shut down, restart capability during shutdown sequence, failure to start during a specific time of shutdown may result in four hour lock-out.

Simulations

Seasonal Scenarios

- Winter: November, December, January, February, March, and April
- Summer: May, June, July, August, September, and October.

Loads applicable to each seasonal scenario to be provided by LADWP

Winter:

- Typical winter weekday: 3195 MW day peak with steep ramp up to 3500 MW in two hours for the PM peak (this happens every day from November through March)
- Typical warm winter day: 3600 MW day peak (this is a typical day during spring solstice)
- Extreme winter day: 2600 MW day peak , steep ramp up to 3100 MW (this is a typical

TASK SCOPE STATEMENT

Requisition No.

Sunday in spring and winter solstices)

Summer:

- Typical summer weekday: 4453 MW day peak (this is representative of a good hot day during spring solstice)
- Typical warm summer day: 5113 MW (this is representative of a good hot day during summer solstice)
- Extreme summer day: 6177 MW day peak (recorded on 9/27/14)

Penetration Levels

- Penetration level shall include existing penetration level up to 40% including 33% penetration level by combinations of VER and distributed PV solar generation as following simulation cases.

Table 2: Simulation Cases with combination of VER and distributed solar

Case Number	Large-Scale VER		Distributed PV Solar		Total	% Penetration
	Wind	Solar	Non-Fit	FIT		
1	502	110	148	31	791	
2	502	788	271	150	1711	
3	502	977	331	149	1959	
4	572	1066	350	148	2136	
5	TBD	TBD	TBD	TBD		

6. Overall Approach: (Provide details of how the task will be carried out. Use Appendix 1 , Work Order Breakdown. Attached detail schedule as Appendix 2.)

Task Manager:

The Consultant shall provide a softcopy and hard copy of all deliverables associated with Subtask 1 in a single report and provide a softcopy and hard copy of all deliverables associated with Subtask 2 in a single report, after LADWP approval of the proposed project schedule and plan for each task.

Consultant's Response:

7. Training Plan: (Provide details of how Consultant will carry out training for LADWP employees.)

Task Manager:

The Consultant shall conduct group and personal hands-on training sessions to train LADWP staff and SMEs at LADWP facilities. Written training manuals, guidelines, and instructions for different aspects of the project are required as specified under the Subtask 2.7.

Consultant's Response:

TASK SCOPE STATEMENT

Requisition No.

8. Presentation at Completion of Task: (Provide details of how Consultant will present the end product.)

Task Manager:

The Consultant shall conduct a presentation at LADWP's JFB after completing each task.

Consultant's Response:

TASK SCOPE STATEMENT

Requisition No.

10. Related Tasks: (List any other tasks/ project activities which are impacted by this task.)

Task Manger:

11. Method of Compensation: (Consultant: List cost for each phase with deliverables. Attach cost estimate. Also include all expected travel expenses such as number of people, number of days, and locations)

Fixed Cost

Task Manager:

The Consultant shall provide the Names, Qualifications, Experience and Labor Categories of all personnel working on this task order. Any change of personnel during the course of the consultant's services shall be notified in writing to LADWP's Contract Administrator Catherine Cordero - Catherine.Cordero@ladwp.com. All personnel must be pre-approved before beginning work and payment is authorized.

The Consultant shall provide a list of the total estimated cost with a breakdown for each deliverable, including personnel and total hours expected for each sub-task

Preapproval is required by the Task Manager for all travel authorities, and purchases made to complete this subtask order. Any invoices submitted for payment without appropriate preapproval shall be denied for payment.

The Consultant's invoice shall itemize the cost associated with each sub-task listed above. If the Consultant performs a combination of various sub-tasks, each invoice shall indicate the itemized cost for the individual subtasks. Any invoice that does not list itemized pricing as described above shall be denied for payment.

Consultants Response:

TASK SCOPE STATEMENT

Requisition No.

12. Key Technical Assumptions: (Briefly describe any assumptions made about the project related to resources, scope, expectations, schedule, etc. Assumptions should be specific and measurable.)

Task Manager:

Consultant's Response:

13. Acceptance Criteria: (Provide details of the contract's acceptance criteria and a description of any significant risks associated with achieving timely acceptance with the plan.)

Task Manager:

Consultant's Response:

14. Pre-requisites to Consultant Personnel Performance: (List required certification or experience, etc.)

Task Manager:

TASK SCOPE STATEMENT

Requisition No.

17. Special Requirement of Affected Organizations

1. INVOICE/PAYMENT MANAGEMENT	AFFECTED: YES <input type="checkbox"/> NO <input type="checkbox"/>
SPECIAL REQUIREMENTS Consultant shall submit monthly invoices in triplicate to: Catherine L. Cordero Contract Administrator Power System Planning & Development Division 111 N. Hope Street, Room 1250 Los Angeles, California 90012 Contact Information: Catherine.Cordero@ladwp.com (213) 367-8769	
2. QUALITY ASSURANCE	AFFECTED: YES <input type="checkbox"/> NO <input type="checkbox"/>
SPECIAL REQUIREMENTS	
3. PURCHASING/CONTRACT MANAGEMENT	AFFECTED: YES <input type="checkbox"/> NO <input type="checkbox"/>
SPECIAL REQUIREMENTS	
4. MANUFACTURING/PRODUCTION	AFFECTED: YES <input type="checkbox"/> NO <input type="checkbox"/>
SPECIAL REQUIREMENTS	
5. OTHER SERVICES AND MAINTENANCE	AFFECTED: YES <input type="checkbox"/> NO <input type="checkbox"/>
SPECIAL REQUIREMENTS	
6. FOREIGN EXCHANGE	AFFECTED: YES <input type="checkbox"/> NO <input type="checkbox"/>
SPECIAL REQUIREMENTS	
7. CONTRACT ADMINISTRATION	AFFECTED: YES <input type="checkbox"/> NO <input type="checkbox"/>
SPECIAL REQUIREMENTS	
8. OTHER AFFECTED ORGANIZATIONS	AFFECTED: YES <input type="checkbox"/> NO <input type="checkbox"/>
SPECIAL REQUIREMENTS * FINAL REVIEW AND APPROVAL OF DELIVERABLES BY LADWP BEFORE FINAL PAYMENTS.	

TASK SCOPE STATEMENT

Requisition No.

20. Commitment and Approval: <i>(Signed approval from all parties – Organization from LADWP and Consultants)</i>		
Organization	Name, Title, and Signature	Date
LADWP Power System Planning and Development Division	Mukhles Bhuiyan, Manager of Grid Planning and Development	
Consultant	Consultant	

TASK SCOPE STATEMENT

Requisition No.

Appendix 1: Work Order Breakdown Structure (WBS) (Create or attach a work breakdown structure for the contract.)

Task Manager:

Consultant's Response:

TASK SCOPE STATEMENT

Requisition No.

Appendix 2: Contract Performance: Schedule *(To attach print out for detail schedule from a Project Management Software, i.e Primavera)*

Task Manager:

Consultant's Response:

Appendix 9

SCPPA Request for Proposals for Renewable Energy and Energy Storage Projects

This space is intentionally left blank



SOUTHERN CALIFORNIA PUBLIC POWER AUTHORITY

Request for Proposals for Renewable Energy and Energy Storage Projects

Issuance Date: February 1, 2014

Amendment Date: March 17, 2014

Response Deadline: December 31, 2014

First Review Date for Energy Storage Proposals: April 1, 2014

Introduction

The Southern California Public Power Authority (SCPPA) is soliciting competitive proposals for renewable energy projects or products consistent with the California Renewable Energy Resources Program (Public Resources Code sec. 25740 et seq.) and the California Renewables Portfolio Standard Program (Public Utilities Code sec. 399.11 et seq.), including amendments enacted in 2011 by passage of California Senate Bill X1 2 (SBX1 2), and energy storage. RFP responses may propose (i) project ownership by SCPPA, (ii) a power purchase agreement (or, for storage, an equivalent commercial agreement with an ownership option, or (iii) a power purchase agreement (or, for storage, an equivalent commercial agreement without an ownership option. Effective February 1, 2014 this Request for Proposals (RFP) replaces all previous RFPs for renewable energy or energy storage projects posted by SCPPA.

Background

SCPPA, a joint powers authority and a public entity organized under the laws of the State of California, was created pursuant to the Government Code of California and a Joint Powers Agreement for the purpose of planning, financing, developing, acquiring, constructing, operating and maintaining projects for the generation or transmission of electric energy as well as procuring or otherwise obtaining associated products and services.

SCPPA is governed by its Board of Directors, which consists of a representative from each of its Member Agencies. The management of SCPPA is under the direction of an Executive Director who is appointed by the Board.

Member Agencies comprise eleven municipalities and one irrigation district which supply electric energy within Southern California, including the municipal utilities of the cities of Anaheim, Azusa, Banning, Burbank, Cerritos, Colton, Glendale, Los Angeles, Pasadena, Riverside, and Vernon, and the Imperial Irrigation District (Member Agencies). Anaheim, Azusa, Banning, Cerritos, Colton, Pasadena, Riverside and Vernon are in the California Independent System Operator's (CAISO) Balancing Authority; LADWP, Burbank and Glendale are in the Los Angeles Department of Water and Power's (LADWP) Balancing Authority; and Imperial Irrigation District operates its own Balancing Authority.

Member Agencies' electric utilities are governed by their respective city councils or other elected legislative local bodies. Many Members established voluntary renewable targets before SBX1 2 went into effect, including the percentage of renewable energy they wish to obtain within their portfolio. Some have set targets as high as 40% by the year 2020. Many of our Members are approaching, or have already exceeded, their interim targets of 20% renewable energy and are now updating their objectives to meet 33% by 2020 as reflected in SBX1 2.

SCPPA has an active working group focused on renewable energy development. This group, with representation from all twelve of the Member Agencies, meets twice a month and has reviewed over seven hundred (700) individual proposals starting in 2007. Many of these projects have advanced into specific contract negotiations, as a result of which over 1,100 MW of capacity are now being or will be delivered in support of our members' renewable objectives.

Equity Participation

SCPPA is well positioned and experienced in facilitating joint ownership structures for renewable power or other projects for the benefit of its Member Agencies. SCPPA can acquire an equity interest in a project and sell 100% of the output to interested Member Agencies at its cost. SCPPA would also consider power purchase agreements or prepayment structures, either with or without an option to purchase the project during the term of the agreement. There is a strong preference by most of the Member Agencies for optionality to purchase an underlying project during the term of the power purchase agreement.

RPS and EPS Compliance

SCPPA continues to seek cost effective resources to support our members' Renewable Portfolio Standard (RPS) objectives for 2016 and forward. This rolling RFP seeks to find a best combination of projects or products to deliver energy from facilities that will be California RPS Compliant (pursuant to Public Utilities Code Sections 399.16 (b)(1) and (b)(2), i.e., energy and associated RECs in Portfolio Content Category 1, which is strongly preferred, or Portfolio Content Category 2) and EPS Compliant (pursuant to Public Utilities Code sections 8340 and 8341) upon COD and throughout the term of the agreement.

This rolling RFP also seeks to find the best combination of projects or products to store energy, including for the purpose of integrating RPS-compliant intermittent renewable energy into our members' systems.

SCPPA requires that during the term of any agreement, Seller shall assume the risk of maintaining and bringing the facility or project into compliance should there be a change in law that would render the facility non-compliant with either RPS or EPS. Since this is one of the critical elements of a renewable project or product for SCPPA, please describe how this risk would be assumed and addressed by Seller.

Proposal Delivery Requirements

One electronic copy of your proposal must be e-mailed to knquyen@scppa.org or delivered on CD or USB flash drive to the address below by no later than 12:00 p.m. on December 31, 2014:

Southern California Public Power Authority

Attention: Kelly Nguyen
1160 Nicole Court
Glendora, California 91740

For general questions, please call the SCPA offices at (626) 793-9364.

Clarification questions regarding this RFP may be addressed to Kelly Nguyen, Director of Energy Systems, at knguyen@scppa.org.

SCPPA members seek tangible and timely opportunities to add renewable technologies to their generation portfolios and/or add storage facilities to their operations and thus will not entertain research or speculative proposals.

Since this is a “rolling RFP,” proposals may be submitted any time during calendar year 2014. SCPPA reserves the right to review all proposals throughout the process of this rolling RFP, to contact proposers at any time to start negotiations, and to execute one or more agreements before the deadline for delivery of proposals.

Respondents who have previously submitted proposals for consideration and have not received formal regrets notifications from SCPPA may submit updates or revisions to the previous submittals with clearly noted reference to the prior submittal(s) and identify proposed changes, all under a new Transmittal Letter.

Newly submitted proposals by a prior Respondent may make reference to prior submittals for any required elements that have not changed (such as experience) rather than resubmitting boilerplate information.

No contact may be made with the Board of Directors, Committee Members, or SCPPA Member Agencies concerning this Request for Proposals.

All information received by SCPPA in response to this Request for Proposals is subject to the California Public Records Act and all submissions may be subject to review in the event of an audit.

Required Elements of Proposals

- 1. Transmittal Letter:** Provide a brief statement of the Respondent's understanding of the work to be done and commitment to perform the work as scheduled, including a summary of any exceptions taken to the RFP requirements, statement of work, specifications, and reference to any proposed contractual terms and conditions required by the Respondent. An officer authorized to bind must sign the proposal on behalf of the Respondent and must include the following declarations on the Transmittal Letter:

“This proposal is genuine, and not sham or collusive, nor made in the interest or in behalf of any person not herein named; the respondent has not directly or indirectly induced or solicited any other respondent to put in a sham bid, or any other person, firm or corporation to refrain from submitting a proposal; and the respondent has not in any manner sought by collusion to secure for themselves an advantage over any other respondent.”

- 2. Applicant Information:** Provide the legal name of the company or entity making the proposal, the legal structure or form of the entity (e.g., Corporation, or LLC), physical address, e-mail address, telephone, and names and titles of individuals authorized to represent the Respondent.

3. **Renewable Category:** Clearly identify the proposal as one or more of the following eligible renewable energy resource electricity products:

- a. Wind, including all air-flow technologies involving a turbine of any type
- b. Geothermal, including all temperature gradient technologies
- c. Biomass, including dedicated waste feedstock or energy crops
- d. Biogas, including landfill, digester gases and gas conversion or gasification technologies where the conversion to electricity occurs on the same premises as the source of fuel
- e. Biogas only: refer to SCPPA's RFP on biogas for delivery of pipeline quality fuel through existing infrastructures to be used at SCPPA's conventional thermal generation plants:
<http://www.scppa.org/Downloads/RFP/RFPforBiogas062310.pdf>
- f. Hydro, including all mass-in-motion technologies involving fluids
- g. Solar, including all photo-voltaic and photo-optic technologies where light is directly converted to electricity
- h. Solar Thermal, including all concentration technologies where a heat transfer medium is used to generate electricity
- i. Municipal Solid Waste (MSW) or Waste to Energy technologies that can demonstrate the absence of incineration and are able to obtain certification as a Renewable Resource by the California Energy Commission
- j. Permanent Load Shifting (PLS), including energy storage and permanent load-shifting technologies with a total round-trip efficiency generally greater than eighty percent (80%)
- k. Environmental attributes not bundled with energy

4. **Energy Storage Solutions (ESS):**

Because of the deadline for publicly-owned utilities to submit energy storage procurement targets (if determined to be feasible) to the California Energy Commission by October 1, 2014, SCPPA Members are actively seeking proposals for energy storage system development in their respective systems. SCPPA anticipates its first in-depth analysis and review of energy storage-related proposals provided pursuant to this RFP during April of 2014.

Therefore, **SCPPA strongly encourages potential Energy Storage Respondents to provide submittals on or before April 1, 2014.** Such submittals should be provided in the form specified in the original RFP. In addition, SCPPA requests that Respondents fill in the attached table for each energy storage system submittal, as completely as possible, to enhance your proposal's competitiveness in the review process.

In addition, energy storage-related proposals will be accepted beyond April 1, 2014 and throughout the term of this RFP. Again, this initial request is intended to encourage proposals that may be immediately evaluated for their near-term cost-effectiveness and viability for Members.

5. **Project Details:** Clearly identify the proposed project, including the following information:

- a. **Project Description:** Project name and location, and phases of development if applicable.
- b. **Contract Quantity:** In MW and GWh/year, and by project phase if applicable, including nameplate rating and proposed amount of energy to be delivered. Please provide all MW increment options available for the project.
- c. **Energy Price (variable):** Expressed in nominal dollars (as of the year of COD) in \$/MWh, and itemized by cost components if applicable; the Energy Price, best and final, will start on the Commercial Operation Date (COD) and may include fixed price annual escalation rates or index

plus fixed price component. Please provide all pricing structure options available, including a prepayment option.

- d. **Energy Price (fixed):** Expressed in nominal dollar value (as of the year of COD) in \$/MWh, with no escalation thereafter.
- e. **Delivery Term:** Minimum term is 1 year with no maximum as the various Member Agencies are seeking both short-term and long-term delivery of energy. Please provide all delivery term options available.
- f. **Energy Availability:** Maximum and minimum monthly capacity factors, seasonal shapes, resource availability profile (i.e., 8760 wind profile of availability), reliability indices (reliability of the distribution system distribution indices to potentially Forced Outage Ratios or Planned Outage Ratios of generators), dispatchability (by unit or phase if applicable) and scheduling requirements/limitations, if any; any rights for SCPPA to perform full or partial dispatch.
- g. **Buyer's Step in Right:** Include SCPPA's requirement in the proposal that the Buyer may assume or cure any default by developer in the land lease.
- h. **Point of Delivery (POD):** Cost of transmission to a delivery point shall be included in the Cost of Energy to one of the following locations where one or more of the SCPPA Members can receive energy:
 - i) Marketplace
 - ii) Westwing
 - iii) NOB
 - iv) Barren Ridge
 - v) Intermountain Power Project Station (IPP) switchyard
 - vi) CAISO Grid (with preference of SP15)
 - vii) Mead 230 kV
 - viii) Mead 500 kV
 - ix) Midpoint Victorville-Lugo
 - x) Blythe-Knob
 - xi) Mirage 230 kV
 - xii) Palo Verde 500 kV switchyard & ISO's Palo Verde/Hassayampa 500 kV tie with SRP BAA
 - xiii) Imperial Valley 230 kV
 - xiv) Perkins 500kV
 - xv) McCullough
 - xvi) North Gila 69 kV (ISO 69 kV tie with APS BAA)

The above listing represents locations where Member Agencies may have existing capacity rights. Other delivery points may be identified by Respondents on the condition that any and all associated costs of transmission ancillary services, and scheduling are included up to the Point of Delivery. Note: Project evaluations will include the full cost of delivery to the customers of SCPPA Members within Southern California.

The point of delivery to the CAISO must indicate whether the project qualifies for Resource Adequacy and/or Local Capacity Requirement capacity benefits.

- i. **Environmental Attributes:** Ensure that SCPPA shall receive any and all environmental attributes associated with the generating facility and the energy output, including but not limited to renewable energy credits and air emission credits or offsets (i.e., Greenhouse Gas Credits, at the location of source and for the gross output of the plant or otherwise credited).
- j. **Combustion:** For any proposals that involve combustion technologies, provide details on the forecasted emissions, emissions controls, and compliance with applicable emissions regulations.

- k. **Category of Environmental Attributes:** Specify whether the project qualifies for Portfolio Content Categories 1, 2 or 3 (“bucket 1, 2 or 3”) under the California Public Resources Code (CPRC) and how the project would comply with the CPRC and any future interpretations of relevant statutes by the California Energy Commission.
- l. **Capacity Rights:** Ensure that SCPPA shall receive any and all capacity rights associated with the project and/or its produced energy.
 - i) Identify any energy and/or associated project capacity to be provided/committed to parties other than SCPPA.
 - ii) Identify any project supporting/associated facilities that require shared use or third party access rights, such as intermediate distribution infrastructure, control rooms, or other intermingled facilities. Describe any controls or provisions to assure the continuation of the described project capacity, e.g., for wind proposals any adjacent or future proposals encroaching on turbine spacing or airflow; for hydro proposals any limitations or regulations on water flow, diversion or water reservoir level maintenance requirements; and other potential impacts on the proposed project.
- m. **Ownership Options:** If the proposal includes an offer of ownership to SCPPA, describe the proposed ownership, terms and conditions, floors and ceilings for purchase prices at different option dates and operational structures (e.g., 100% SCPPA-owned turn-key, corporation, general partnership, limited partnership).
 - i) In the case of an offer of initial ownership to SCPPA, a purchase price at Commercial Operation Date (COD) shall be specified (and expressed as \$/kW) along with an estimate of all recurring owner costs, including but not limited to operation and maintenance costs, taxes, lease payments, royalties, and insurance.
 - ii) In case of an offer of a Purchase Power Agreement (PPA) with a purchase option, the proposal shall include (a) a delivered energy price, in \$/MWh, for the energy, environmental attributes and capacity (as Cost of Energy within Section 4.c.), (b) a buyout price or detailed formula to calculate such a buyout price for each future date on which a buyout would be offered; and (c) conditions for buyout, such as expiration of tax credits or other project events.
 - iii) For PPAs, terms up to the life of the facility will be considered.
- n. **Project Plan to Commercial Operation Date:** Identify the proposed commercial operation date with a satisfactory major milestone schedule that includes at least the following:
 - i) Proposed schedule for obtaining and developing site access and control through executed leases, fee purchases, approvals, or other means.
 - ii) Details of any prior or existing settlements made for environmental mitigation and clearly identified post-construction or pass-forward mitigation obligations that would be forwarded to SCPPA in the event a contract is executed (e.g., reserve or offset land for environmental habitat or reconstruction).
 - iii) Proposed schedule for obtaining construction and operational permits and licenses, and construction financing.
 - iv) Proposed construction schedule, including major equipment purchasing, anticipated Factory Acceptance Testing of major components, Site Tests, commencement of test-energy and Commercial Operation Date (COD).
 - v) For projects or operations requiring water or make-up water, description of the water supply requirements and provisions for supply.
 - vi) Proposed schedule or application status to acquire necessary transmission and interconnection service.
 - vii) Description of whether and to what extent any environmental studies have been carried out with respect to the proposed project and how compliance with the California Environmental

Quality Act (CEQA), which is a requirement before an agreement can be executed by SCPPA, might be effectuated, including, if the Project is located outside California, how Title 14 Section 15277 of the California Administrative Code is or will be addressed by the project.

- o. **Applicable to Energy Storage Solutions only:** Provide the equivalent information, to the extent possible, for 5(a) through 5(n) above. In addition, please provide as much information as possible in the table in **Appendix A** (posted as a separate document).
- 6. Experience:** Respondent will clearly identify project participants and management team including those responsible for design, construction, permitting, operations and maintenance.
- a. Describe your firm's organizational structure, management qualifications, and other contract related qualifications, including number of years the firm has been in business.
 - b. Specify key employees and describe their experience with the development, construction, finance closing, commercial operation, and maintenance of similar projects as proposed by Respondent in response to this RFP.
 - c. Provide current financial statements of all entities involved as Project participants or as part of management team. This shall include items such as audited financial statements (not more than twelve months old) annual reports, FERC Form 1, and any other applicable financial information. If none of the above are available, Respondent shall provide verifiable financial statements for the past three (3) years if available, and Respondent's Dunn & Bradstreet identification number, where available.
 - d. Provide a commitment statement for the retention and use of key employees as proposed, their availability to initiate and sustain the proposal, as well as planned supplemental employees if key employees are not available to assure project delivery.
 - e. Indicate any and all pending litigation that could affect the viability of Respondent's proposal or Respondent's financial stability.
 - f. Identify existing projects in commercial operation that Respondent has developed and/or operates. Provide a list of references for similar projects completed, including a contact person, phone number and address.
 - g. State whether Respondent will use subcontractors to perform services pursuant to the contract. Should the use of subcontractors be included, Respondent shall provide the same assurances of competence for the subcontractor, plus the demonstrated ability to manage and supervise the subcontracted work. Subcontractors shall not be allowed to further subcontract with others for work on this program. The provisions of this contract shall apply to all subcontractors in the same manner as to the Respondent.
 - h. Describe the project/generation technology and technical resource data, including any studies or reports regarding the resource.

Terms and Conditions

1. If selected, SCPPA desires to enter into exclusive negotiations with respondent as may be facilitated through execution of a Letter of Intent (LOI), Exclusivity Agreement or other agreements.
2. SCPPA reserves the right to cancel this RFP at any time, reject any and all proposals and to waive irregularities if any.
3. SCPPA shall determine at its sole discretion the value of any and/or all proposals including price and non-price attributes.

4. Proposals may be sub-divided or combined with other proposals, at SCPPA's sole discretion.
5. SCPPA shall perform an initial screening evaluation to identify and eliminate any proposals that are, for example, not responsive to the RFP, do not meet the minimum requirements set forth in the RFP, are not economically competitive with other proposals, or are submitted by Respondents that lack appropriate creditworthiness, sufficient financial resources, or qualifications to provide dependable and reliable services for this RFP.
6. SCPPA reserves the right to submit follow up questions or inquiries to request clarification of information submitted and to request additional information from any one or more of the Respondents.
7. SCPPA reserves the right, without qualification and in its sole discretion, to accept or reject any or all proposals for any reason without explanation to the Respondent, or to make any award to that Respondent, who, in the opinion of SCPPA, will provide the most value to SCPPA and its Members.
8. SCPPA may decline to enter into any potential engagement agreement or contract with any Respondent, terminate negotiations with any Respondent, or to abandon the request for proposal process in its entirety.
9. SCPPA reserves the right to make an award, at its sole discretion, irrespective of price or technical ability, if SCPPA determines that to do so would result in the greatest value to SCPPA and its Members.
10. Those Respondents who submit proposals agree to do so without legal recourse against SCPPA, its Members, their directors, officers, employees and agents for rejection of their proposal(s) or for failure to execute or act on their proposal for any reason.
11. SCPPA shall not be liable to any Respondent or party in law or equity for any reason whatsoever for any acts or omissions arising out of or in connection with this RFP.
12. SCPPA shall not be liable for any costs incurred by any Respondents in preparing any information for submission in connection with this RFP process or any and all costs resulting from responding to this RFP. Any and all such costs whatsoever shall remain the sole responsibility of the Respondent.
13. SCPPA may require certain performance assurances from Respondents prior to entering into negotiations for work that may result from this RFP. Such assurances may potentially include a requirement that Respondents provide some form of performance security.
14. Prior to contract award, the successful Respondent shall supply a detailed breakdown of the applicable overheads and fringe benefit costs that are part of the labor rates and other direct costs associated with the services to be performed.
15. SCPPA Members, either collectively or individually may contact Respondents to discuss or enter into negotiations regarding a proposal. SCPPA is not responsible or liable for individual Members interactions with the Respondent which are not entirely conducted through SCPPA or at SCPPA's option or election to engage the Respondent as defined within the RFP.

16. Submission of a Proposal constitutes acknowledgement that the Respondent has read and agrees to be bound by the terms and specifications of this RFP and any addenda subsequently issued by SCPPA.
17. Information in this RFP is accurate to the best of SCPPA's and its Members' knowledge but is not guaranteed to be correct. Respondents are expected to complete all of their due diligence activities prior to entering into any final contract negotiations with SCPPA.
18. SCPPA reserves the right to reject any Proposal for any reason without cause. SCPPA reserves the right to enter into relationships with more than one Respondent, can choose not to proceed with any Respondent with respect to one or more categories of services, and can choose to suspend this RFP or to issue a new RFP that would supersede and replace this RFP.
19. SCPPA reserves the right to negotiate definitive agreements including but not limited to power purchase agreements and other agreements with Respondent with any and all terms and conditions that SCPPA and/or its Members deem appropriate or desirable, whether or not such terms or conditions are specifically set forth in this RFP.

Additional Requirements for Proposal

1. **Consideration of Responses:** Submitted proposals should be prepared simply and economically, without the inclusion of unnecessary promotional materials. Proposals should be submitted on recycled paper that has a minimum of thirty percent (30%) post-consumer recycled content and duplex copied (double-sided pages) where possible. (Applicable when LADWP is a contract participant)
2. **Insurance, Licensing, or other Certification:** If selected, the Respondent will be required to maintain sufficient insurance, licenses, or other required certifications for the type of work being performed. SCPPA or its Members may require specific insurance coverage to be established and maintained during the course of work and as a condition of award or continuation of contract.
3. **Non-Discrimination/Equal Employment Practices/Affirmative Action Plan:** If selected, the Respondent and each of its known subcontractors may be required to complete and file an acceptable Affirmative Action Plan. The Affirmative Action Plan may be set forth in the form required as a business practice by the Department of Water and Power of the City of Los Angeles which is SCPPA's largest Member. (Applicable when LADWP is a contract participant)
4. **Living Wage Ordinance:** If selected, the Respondent may be required to comply with the applicable provisions of the City of Los Angeles Living Wage Ordinance and the City of Los Angeles Service Contract Workers Retention Ordinance. The Living Wage Ordinance provisions are found in Section 10.36 of the Los Angeles City Administrative Code; and the Service Contract Workers Retention Ordinance are found in Section 10.37 of the Los Angeles Administrative Code (SCWRO/LW0). (Applicable when LADWP is a contract participant)
5. **Prevailing Wage Rates:** If selected, the Respondent will be required to conform to prevailing wage rates applicable to the location(s) where any work is being performed. Workers shall be paid not less than prevailing wages pursuant to determinations of the Director of Industrial Relations as applicable

in accordance with the California Labor Code. To access the most current information on effective determination rates, Respondent shall contact:

Department of Industrial Relations
 Division of Labor Statistics and Research
 PO Box 420603, San Francisco, CA 94142-0603
 Division Office Telephone: (415) 703-4780
 Prevailing Wage Unit Telephone: (415) 703-4774
 Web: <http://www.dir.ca.gov/dlsr/DPreWageDetermination.htm>

6. **Child Support Policy:** If selected, Respondent may be required to comply with the City of Los Angeles Ordinance No. 172401, which requires all contractors and subcontractors performing work to comply with all reporting requirements and wage earning assignments and wage earning assignments relative to court ordered child support. (Applicable when LADWP is a contract participant)
7. **Supplier Diversity:** Respondents shall take reasonable steps to ensure that all available business enterprises, including Small Business Enterprises (SBEs) and Disabled Veteran Business Enterprises (DVBES) have an equal opportunity to compete for and participate in the work being requested by this RFP. Efforts to obtain participation of SBEs, DVBES, and other business enterprises may reasonably be expected to produce a twenty percent (20%) participation goal for SBEs and a three percent (3%) participation goal for DVBES. For the purpose of this RFP, SCPPA's Supplier Diversity program is modeled after that of the Los Angeles Department of Water and Power. Further information concerning the Supplier Diversity Program may be obtained from the Supply Chain Services Division of the Los Angeles Department of Water and Power. (Applicable when LADWP is a contract participant)
8. **SCPPA-Furnished Property:** SCPPA or a Member's utility drawings, specifications, and other media furnished for the Respondent's use shall not be furnished to others without written authorization from SCPPA or the applicable Member(s).
9. **Contractor-Furnished Property:** Upon completion of all work under any agreement developed as a result of this RFP, ownership and title to reports, documents, drawings, specifications, estimates, and any other document produced as a result of the agreement shall automatically be vested to SCPPA and no further agreement will be necessary for the transfer of ownership to SCPPA. SCPPA has the sole right to distribute, reproduce, publish, license, or grant permission to use all or a portion of the deliverable documentation, work product or presentations as it determines in its sole discretion.

History

Date	Action	Change Tracking
02-01-14	RFP issuance	New
03-17-14	Amendment 1	Added #4 to the Required Elements of Proposals; added section (o) to #5 Project Details section and new excel table as Appendix A