



City of Palo Alto

City Council Staff Report

(ID # 4384)

Report Type: Consent Calendar

Meeting Date: 2/10/2014

Summary Title: Do Not Set Energy Storage Procurement Targets

Title: Utilities Advisory Commission Recommendation that the Council of the City of Palo Alto Adopt a Resolution Determining that a Target for the City of Palo Alto Utilities to Procure Energy Storage Systems is Not Appropriate Due to Lack of Cost-effective Options

From: City Manager

Lead Department: Utilities

Recommendation

Staff and the Utilities Advisory Commission (UAC) recommend that the City Council adopt a resolution determining that a target for the City of Palo Alto Utilities (CPAU) to procure energy storage systems is not appropriate due to lack of cost-effective options, a determination required under California law. This recommendation does not preclude CPAU from pursuing cost-effective energy storage based technologies that enhance utility operations.

Executive Summary

California's energy storage law, (hereinafter referred to as Assembly Bill (AB) 2514),¹ requires the governing board of each publicly-owned utility (POU) to "determine appropriate targets, if any, for the utility to procure viable and cost-effective energy storage systems..."² In addition to requiring POUs to evaluate the feasibility of energy storage targets, AB 2514 also requires that "...[a]ll procurement of energy storage systems" by a POUs "...shall be cost-effective."³

This report specifically examines the cost and benefit of various energy storage systems for local applications, both from the utility and customer perspective. Over the next five years, the costs of utility-owned and operated energy storage exceed the value of benefits, and are

¹ AB 2514 (Chapter 469, Statutes of 2010).

² Cal. Pub. Util. Code § 2836(b)(1),

³ Cal. Pub. Util. Code § 2836.6.

therefore not cost-effective for CPAU, its customers or the City. In addition, staff has determined that there is currently no need for the City to procure energy storage systems within Palo Alto for purposes of load-shifting, demand response, deferral of distribution system upgrades, or integration of distributed generation.

Customer owned storage strategies to shift load from peak to off-peak hours using thermal energy storage were found to be cost-effective from the customer perspective in some cases. It is recommended that such load shifting strategies be encouraged in Palo Alto; however, no rebate or incentive is currently recommended for thermal energy storage since the systems are not cost-effective from the societal perspective.

Given current and projected conditions, staff finds that neither the utility owned energy storage strategies, nor incentives for customer owned energy storage procurement are cost-effective options for the City.

For these reasons, and to satisfy the City's obligations under AB 2514 and Long Term Electric Acquisition Plan (LEAP), staff and the UAC recommend that the City Council decline to adopt an energy storage procurement target because energy storage, including thermal energy storage (TES), is not cost-effective, and therefore is inappropriate for CPAU, its customers, or the City at this time. CPAU will nevertheless encourage commercial customers to consider procurement of energy storage systems, including TES, where cost-effective.

AB 2514 requires that the City reevaluate its determination concerning the need for an energy storage procurement target once every three (3) years.⁴ CPAU staff will return to the UAC and City Council to reassess the position recommended in this Staff Report within that time frame

In the long term, energy storage is expected to have an important role in the statewide electric power system, and hence staff may propose that some funds be allocated to an energy storage pilot project in order for CPAU to gain experience with utility-owned energy storage installation and operation. A pilot program could be implemented within the parameters of the City's existing Demand Response Program initiatives, maximizing value of electric vehicle storage capabilities, or optimizing use of solar photovoltaic (PV) output. As such opportunities arise, staff may recommend projects for UAC recommendation and City Council consideration and approval.

⁴ Cal. Pub. Util. Code § 2836(b)(3)

Background

Energy Storage Systems: Definition and Need

The fundamental function of energy storage systems is to absorb energy, store it for a period of time with minimal loss, and then release it. When deployed in the electric power system, energy storage provides flexibility that facilitates the real-time balance between electricity supply and demand. Maintaining this balance becomes more challenging as the portion of electricity coming from intermittent renewable energy sources grows.

Typically this balance is achieved by keeping some generating capacity in reserve to ensure sufficient supply at all times and by adjusting the output of fast-responding resources like hydropower; however, energy storage systems have the potential to perform this role more efficiently and effectively.

Rechargeable batteries are perhaps the most familiar energy storage technology. Large battery energy storage systems can be connected to the transmission grid to take up excess wind or sun power when demand for electricity is low, and release it when demand is high. Such a battery installation also provides valuable frequency regulation far more effectively than a typical generating facility.

At the other end of the electric power system, customer-sited energy storage can reduce customer costs and increase reliability while also benefiting the utility by reducing peak demands on the distribution system. TES is the energy storage technology most commonly used for customer-sited applications.⁵ These systems are typically used to shift electricity use for commercial space cooling from peak to off-peak periods of the day.

As the examples above suggest, a variety of technologies can be used for energy storage in a wide range of applications throughout the electric power system. The type, performance and location of an energy storage system determine the benefits it can provide.

Energy Storage in California and Palo Alto

Recent legislative and regulatory shifts along with continued growth in intermittent renewable energy and advances in energy storage technology all indicate that energy storage will play an increasing role in the electric infrastructure of the Western United States. Energy storage can provide a number of crucial services needed to achieve a resilient and low carbon electric power system.

⁵ Market Evaluation for Energy Storage in the United States, KEMA Inc. 2012 and 2013.

Approved in late 2010, California’s energy storage law, AB 2514, requires the governing board of each POU to “determine appropriate targets, if any, for the utility to procure viable and cost-effective energy storage systems.”⁶ As defined by the law, an energy storage system must absorb energy, store it for a period of time, and then dispatch that energy⁷. At this time, conventional hydropower is not eligible to meet investor-owned utility energy storage targets set by the California Public Utilities Commission (CPUC); however, the CPUC continues to consider the operational characteristics and potential uses for large pumped storage options in workshops and other forums. Energy storage procurement includes the use of energy storage devices that are owned by customers or other third parties.

AB 2514 explicitly states that all energy storage procurement by POUs must be cost-effective.⁸ Because no cost-effective options exist, staff recommends that City Council decline to set an energy storage procurement target. If any targets are deemed appropriate, they must be adopted by the City Council by October 1, 2014. The City’s determinations regarding adoption of energy storage procurement targets, even the decision to decline to adopt a target, must be re-evaluated at least once every three years and must be reported to the California Energy Commission (CEC).

In October 2013 the CPUC established an energy storage target of 1,325 megawatts for investor owned utilities (IOUs) by 2020, with installations required no later than the end of 2024.⁹ The CPUC decision also establishes a target for Community Choice Aggregators and electric service providers to procure energy storage equal to 1 percent of their annual 2020 peak load by 2020 with installation no later than 2024, consistent with the requirements for the IOUs.¹⁰ Additional legislative and regulatory drivers related to storage technologies are summarized in Attachment F.

In 2011, the City of Palo Alto adopted its LEAP, which includes two implementation tasks concerning energy storage: Task 7 requires an assessment of the feasibility and cost-effectiveness of thermal energy storage for shifting load from on-peak to off-peak periods for demand response or for meeting any energy storage needs; and Task 21 calls for assessment of the need for and value of energy storage to support local renewable distributed generation

⁶ Cal. Pub. Util. Code § 2836(b)(1).

⁷ Cal. Pub. Util. Code 2835(a)(1)-(4).

⁸ Cal. Pub. Util. Code § 2836.6.

⁹ CPUC Decision 13-10-040 (<http://docs.cpuc.ca.gov/PublishedDocs/Published/G000/M079/K533/79533378.PDF>).

¹⁰ CPUC Decision 13-10-040 (<http://docs.cpuc.ca.gov/PublishedDocs/Published/G000/M079/K533/79533378.PDF>).

resources (Staff Report 2710). These tasks include a requirement to determine energy storage procurement targets in accordance with AB 2514.

CPAU has not offered an energy storage program since the late 1980s, when a generous incentive program for TES was available through the Partners Program for commercial customers (see Attachment E for more details). These incentives were motivated by steep and ratcheted demand charges from PG&E that provided a large incentive for CPAU to shift load from peak to off-peak hours. However, these charges no longer apply.

At least seven large commercial customers took advantage of the Partners Program's TES incentives. Currently, only two of those systems are known to still exist, and neither is currently being used to shift cooling load. Other systems have been eliminated due to failures, space constraints, or lack of engaged operation and maintenance.

Discussion

The following section addresses the feasibility, need, and value of energy storage in Palo Alto. These are discussed through the framework of cost-effectiveness, as called for in the LEAP implementation plan, and form the basis for the recommendation from staff and the UAC that the City Council exercise its option under AB 2514 to decline to adopt energy storage procurement targets because such targets are not appropriate. A variety of applications are analyzed and compared with the applicable technology having the lowest cost. Wherever possible, analyses conducted by or for other California utilities are incorporated.

Review of Energy Storage Technologies

A comprehensive description of the wide array of energy storage technologies is provided in Attachment C. The table below summarizes a few key parameters associated with the major energy storage technologies most widely available in the U.S. today. The cost of energy storage typically includes a power (kilowatt, or kW) component associated with the power conversion part of the system and an energy (kilowatt-hour, or kWh) component associated with the energy storage part of the system.

Table 1: Energy Storage Technology Summary¹¹

Technology	Cost	AC to AC Roundtrip Efficiency	Notes
Lead-Acid batteries	\$400/kW + \$330/kWh	70-80%	Most mature battery technology
Li-ion batteries	\$400/kW + \$600/kWh	85%	Mature technology
Na-S batteries	\$350/kW + \$350/kWh	75-80%	Production temporarily halted due to fire concerns
Pumped Hydro	\$1,200/kW + \$75/kWh	70-85%	Accounts for greatest amount of energy storage today, typically large-scale
Thermal Energy Storage	\$500 - 1,000/kW for 6 hours of load shift	95-100%	Limited to cooling end uses and to customer-sited applications

Energy Storage Applications and Benefits in Palo Alto

As suggested previously, the benefits associated with energy storage, and hence its value, depend on the application. Figure 1 below summarizes benefits associated with different energy storage applications relevant to Palo Alto and considered in this analysis. The open circles in the figure depict applications that require a third-party aggregator to capture the benefit. For example, storage system located at electrical substations in Palo Alto could provide all the benefits except the benefit of providing an electrical customer with their utility bill reduction. However, a smaller storage system located at a customer premises could provide all the benefits, but most of the benefits can accrue only if a third-party can provide storage system aggregation service.

¹¹ The information in this chart is from a variety of sources; cost data is primarily from Sandia Report No. SAND2011-2730, *Energy Storage Systems Cost Update*. Schoenung, <http://prod.sandia.gov/techlib/access-control.cgi/2011/112730.pdf>. More detailed version of Table 1 available in Appendix A.

Figure 1: Energy Storage Applications and Benefits for Palo Alto

Application\Benefit:	Regulation		Voltage Control		Capacity		Distr. Deferral		DG Integration		Arbitrage		Reliability		Bill Reduction	
	System		CPAU						Customer							
Outside Palo Alto	●	●	●					●								
Substation	●	●	●	●	●	●	●	●	●	●	●	●				
Distribution (CES)	○	○	●	●	●	●	●	●	●	●	●	●				
Customer Energy Mgt.	○	○	○	○	○	○	○	○	○	○	○	●	●	●	●	●
Customer TES								○				●	●	●	●	●

○ = Utility or 3rd party aggregation needed

Attachment D describes each electrical energy storage application and benefit in detail before presenting the cost-effectiveness analysis and results for electrical energy storage in Palo Alto. TES is analyzed separately in Attachment E because of its unique association with building cooling needs and consequently its narrow set of benefits.

Summary of Electrical Energy Storage Cost-Effectiveness Results

As detailed in Attachment D, the least cost energy storage technology today is well over 25% more costly than the present value of energy storage in a the best-case application. In addition, Palo Alto does not have any high value applications such as substation or distribution feeder upgrade deferral. As a result, electrical energy storage is not yet cost effective for Palo Alto; however, battery technology is expected to improve over time, and energy storage using better technology may be cost effective in a 5 to 10 year timeframe. Based on a variety of factors including current CPAU load projections, rooftop PV penetration, and distribution system capacity, the analysis did not find a compelling need to establish energy storage goals for CPAU at this time.

While the growth of large-scale renewable energy will increase the need for grid balancing services which energy storage can provide, meeting this need is in the domain of the California Independent System Operator (CAISO), the transmission grid operator. CPAU’s 54 MW share of the Calaveras hydroelectric project and associated reservoir storage has the capability to adequately meet Palo Alto’s load balancing needs within the CAISO grid over the next 5 years.

Summary of TES Cost-Effectiveness

Commercial Customer Perspective

The most cost-effective TES scenario is for commercial customers who are able to use a TES system to reduce the size of their cooling equipment. Due to the capital cost savings associated with this scenario, a simple payback of less than one year for TES is possible. If this capital cost savings is not possible due to the current condition or design of the cooling system, a TES system can achieve a simple payback of 6.1 years, which is still a potentially cost-effective investment. These results do not include the value of space taken up by a TES system, which can significantly reduce the cost-effectiveness of TES. For the complete analysis of TES system options, see Attachment E.

One surprising finding was that customer bill savings resulting from a TES system are higher under the standard rate than the time-of-use rate (TOU). In both instances, the majority of savings are due to reduced demand charges—and demand charges under the standard rate are significantly higher than under the TOU rate. This finding merits further investigation.

Utility Perspective

A customer-sited TES, when operated to reduce a customer's bills, will also result in avoided costs to the utility due to a reduction in peak energy and capacity purchases. Staff's analysis found that for the same TES system, the utility's avoided costs are approximately 1/3 to 1/4 as large as the customer bill savings. Hence, the customer load shifting that occurs with a TES system may result in other customers subsidizing the load shifting customer. Any incentive for load shifting could further exacerbate this ratepayer impact and would require thorough analysis of the rate structure offered.

Finally, a program to install customer-sited, but utility-owned and operated, TES systems was considered. This model has been used effectively by other California utilities to reduce peak loads. These systems can be cost-effective for utilities that are facing a need to build new, expensive generation capacity. For Palo Alto, it was found that such systems are not economically viable, with net present values far below zero.

Recommendations

1. Do Not Establish An Energy Storage Systems Procurement Target for Palo Alto

To satisfy the City's obligations under AB 2514 and the LEAP, staff and the UAC recommend that the City Council decline to set an energy storage systems procurement target, because such a target is not cost-effective. As no current energy storage applications are cost-effective or are anticipated to be cost-effective in the next five years, staff recommends that Council

decline to set targets for the utility to procure “viable and cost-effective energy storage systems.” This determination must be revisited at least every three years pursuant to AB 2514.

Although Energy storage is not currently cost-effective, there are other strategies currently being undertaken by CPAU to address the challenge of matching electrical demand and supply, including a demand response program, in which participating customers curtail their load for a period in response to a signal from the utility. Also underway are programs that target electric vehicle charging, either reducing such loads at critical times through demand response, or more permanently through rates which favor off-peak charging. Such programs to shift load and curtail peak load also benefit customers through bill savings and by lowering the overall system costs to customers.

2. Incentives for TES Not Recommended

Since TES systems are not cost-effective from the societal perspective, staff recommends that no incentives for TES be adopted at this time.

3. Encourage Commercial Customers to Consider Energy Storage Systems Where Cost-effective

As TES and other load shifting strategies can be cost-effective for Palo Alto commercial electric ratepayers, the City should encourage its customers to evaluate such systems. Emphasis should be placed on new construction or system upgrade opportunities where capital cost savings can be realized.

Commission Review and Recommendation

The UAC discussed staff’s recommendation at its December 4, 2013 meeting. Commissioners stated that they supported staff’s recommendation that the City not establish a goal to acquire energy storage because they are not cost-effective, but the UAC remained interested in whether those technologies may become cost-effective in the future. One Commissioner suggested that CPAU consider testing energy storage technologies under the Utilities Emerging Technologies Test Bed Program.

The UAC voted unanimously (5-0, with Chair Cook and Commissioner Waldfogel absent) to recommend that the City Council decline to set an energy storage procurement target for CPAU because such a target is not cost-effective. The excerpted notes from the UAC’s December 4, 2013 meeting are provided as Attachment B.

Resource Impact

The recommended action to not establish an energy storage procurement target has no budgetary or staff resource impacts.

Policy Implications

The recommended action sets new Council policy. This policy will be revisited every three years as required by AB 2514.

Environmental Review

The decision not to adopt energy storage procurement targets or incentives for TES does not meet the definition of a project, pursuant to Public Resources Code Section 21065, thus no California Environmental Quality Act review is required.

Next Steps

If the City Council declines to adopt an energy storage target for CPAU at this time, the City's determination will be communicated to the CEC. Staff will continue to evaluate the value and application of energy storage options on a case-by-case basis as they arise, and bring the decision not to establish energy storage procurement targets back to the UAC and the City Council within three (3) years as required by AB 2514.

Attachments:

- Attachment A: Resolution (PDF)
- Attachment B: Excerpted Notes from the UAC Meeting of December 4, 2013 (PDF)
- Attachment C: Energy Storage Technologies and Applications (PDF)
- Attachment D: Electric Energy Storage in Palo Alto (PDF)
- Attachment E: Thermal Energy Storage in Palo Alto (PDF)
- Attachment F: Energy Storage Regulations, Policies and Incentives (PDF)

Resolution No. _____

Resolution of the Council of the City of Palo Alto Determining that a Target for the City of Palo Alto Utilities to Procure Energy Storage Systems is Not Appropriate Due to Lack of Cost-Effective Options

RECITALS

- A. California’s energy storage law, hereinafter referred to as Assembly Bill (AB) 2514, requires the governing board of each local publicly-owned electric utility (POU) to determine appropriate targets, if any, for the utility to procure viable and cost-effective energy storage systems.
- B. In addition to requiring POUs to evaluate the feasibility of energy storage targets, AB 2514 also requires that all procurement of energy storage systems by a POU be cost-effective.
- C. To conform to California Public Utilities Code § 2836(b)(1) and § 2836.6, and consistent with the City’s Long-Term Acquisition Plan (LEAP), staff undertook a study to determine the viability and cost-effectiveness of energy storage to serve electric utility customers in Palo Alto, which included an investigation into a variety of energy storage technologies and their viability and cost-effectiveness.
- D. Based on that study, staff found that the least cost energy storage technology today is more costly than the present value of energy storage in the best case application, even when a variety of factors including current CPAU load projections, rooftop PV penetration, and distribution system capacity were considered, such that energy storage systems are not cost-effective at this time.
- E. At its December 4, 2013 meeting, the UAC unanimously recommended that the City Council decline to set an energy storage procurement target for the City of Palo Alto or provide rebate incentives for thermal energy storage because such targets and incentives are not cost-effective.
- F. The Council has reviewed staff’s study, the resulting staff report and the UAC’s recommendation.
- G. Based on that review, Council determines that that a target for the City of Palo Alto Utilities to procure energy storage systems is not appropriate due to lack of cost-effective energy storage options.
- H. AB 2514 requires Palo Alto to reevaluate this determination concerning the need for an energy storage procurement target once every three years.

The Council of the City of Palo Alto ("City") RESOLVES as follows:

SECTION 1. To satisfy the City's obligations pursuant to AB 2514 and LEAP, the Council determines that setting a target for the City of Palo Alto Utilities to procure energy storage systems is not appropriate due to lack of cost-effective energy storage system options.

SECTION 2. The Council will reevaluate its decision not to set an energy storage system procurement target for the City of Palo Alto Utilities within three years, as required by AB 2514.

SECTION 3. The Council finds that the adoption of this resolution is not subject to California Environmental Quality Act review because it does not constitute a project under California Public Resources Code section 21065.

INTRODUCED AND PASSED:

AYES:

NOES:

ABSENT:

ABSTENTIONS:

ATTEST:

City Clerk

Mayor

APPROVED AS TO FORM:

APPROVED:

Senior Deputy City Attorney

City Manager

Director of Utilities

Director of Administrative Services



EXCERPTED FINAL MINUTES OF THE DECEMBER 4, 2013 UTILITIES ADVISORY COMMISSION MEETING

ITEM 3: ACTION: Staff Recommendation that the Utilities Advisory Commission Recommend that the City Council Adopt a Resolution Declining to Set an Energy Procurement Target for the City of Palo Alto Utilities or Provide Thermal Energy Storage Rebate Incentives Because Such Targets and Incentives are Not Cost-Effective

Director Fong acknowledged Senior Resource Planner Shiva Swaminathan and intern Larsen Plano who worked on the report.

Commissioner Eglash stated that he enjoyed the report and learned a lot about storage. He supports the conclusion. He stated that it takes lot of energy to build a battery, which is an issue and we can find ourselves in a situation that we invest so much energy to build the product that it takes a lot of time to recover that energy. So if Palo Alto wants to do things "right" as a leader, we think about cost and energy! Commissioner Eglash added that the technologies described in the report are active areas of research and he encouraged CPAU to consider testing these technologies under the emerging technologies program.

Commissioner Hall stated that the report was very helpful and well-constructed. He asked which applications would be beneficial in Palo Alto if there was a change in the characteristics of the system in the future. Swaminathan replied that the storage technologies could become valuable because of their ability to ramp up and down quickly to integrate variable renewable energy sources such as wind and solar. The market price for those services, called "regulation", would have to increase substantially before the storage technologies would be cost effective. In addition, if loads grow on some of the City's electric feeders, adding storage at a substation could alleviate the load on the feeders. However, this was not expected in the next 10 years. Swaminathan added that the cost of these technologies would have to fall considerably before they were cost effective in Palo Alto.

ACTION:

Commissioner Eglash made a motion to recommend that the UAC recommend that Council decline to set an energy procurement target for CPAU. Commissioner Hall seconded the motion. The motion carried unanimously (5-0) with Chair Cook and Commissioner Waldfogel absent.

ATTACHMENT C

ENERGY STORAGE TECHNOLOGIES AND APPLICATIONS

OVERVIEW AND ORGANIZATION

A description of the various energy storage technologies is given in this attachment. The technologies are categorized according to the fundamental method of energy storage as summarized in the following list.

- **Primary Fuel Energy Storage:** systems which store energy in the form of primary fuels used as inputs for electricity generation
 - Technologies: Natural gas storage, Concentrated Solar Power Molten Salt tanks
 - Applications: Generating facilities only
- **Electrical Energy Storage:** systems which store energy in the form of moving or stationary electrical charge after it has been generated
 - Technologies: Batteries, Capacitors, Superconducting magnetic energy storage
 - Applications: can be used anywhere in the electric power system: Generation, Transmission, Distribution, or Customer
- **Non-electrical Energy Storage for Reconversion to Electrical Energy:** systems which convert electrical energy to another form for storage, and then convert it back to electricity upon release
 - Technologies: Pumped hydro, Compressed air energy storage, Hydrogen, flywheel
 - Applications: can be used anywhere in the system, but mostly large facilities connected to the transmission grid due to economies of scale
- **Non-electrical Energy Storage for Direct Use:** systems which convert electrical energy to another form for storage, and then use that energy without reconversion
 - Thermal (heat or cool)
 - Applications: Customer-sited only
- **Unconventional “Energy Storage”:** systems which provide many of the same benefits of energy storage while not meeting the definition of energy storage
 - Time-shifting loads/DR, EV Batteries, Conventional Hydro
 - Applications: these technologies have applications where electricity is added or removed from the system: generation and customer sites.

The primary sources for this section are several recent reports which describe the broad range of energy storage technologies, from sources such as Sandia National Lab¹, the Electric Power Research Institute^{2,3}, and the U.S. Congressional Research Service⁴

¹ Energy Storage Systems Cost Update. S. Sohoenung. Sandia Report SAND2011-2730. April 2011.

² EPRI-DOE Handbook of Energy Storage for Transmission and Distribution Applications, EPRI, Palo Alto, CA, and the U.S. Department of Energy, Washington, DC: 2003. 1001834.

³ Electric Energy Storage Technology Options: A White Paper Primer on Applications, Costs, and Benefits. EPRI, Palo Alto, CA, 2010. 1020676.

The table below summarizes key parameters associated with the major energy storage technologies most widely available in today.

Technology	U.S. Installed ⁵	Energy Density	Cycle Life	Cost	AC to AC Roundtrip Efficiency	Notes
Lead-Acid batteries	45 MW	35 Wh/kg	4,000, depends on depth of discharge	\$400/kW + \$330/kWh	70-80%	Most mature battery technology
Li-ion batteries	55 MW	70-200 Wh/kg	Similar to Lead-Acid	\$400/kW + \$600/kWh	85%	Mature technology
Na-S batteries	18 MW	150 Wh/kg	4500	\$350/kWh + \$350/kW	75-80%	Production temporarily halted due to fire concerns
Pumped Hydro	500 MW	N/A		\$1,200/kW + \$75/kWh	70-85%	Accounts for greatest amount of energy storage today, typically large scale
Thermal Energy Storage	1,000 MW	15 Wh/kg 7,000Wh/m ²	15-20 years	\$500 - 1,000/kW for 6 hours of load shift. .	95-100%	Limited to cooling end uses and to customer sited applications

Table C1: Energy Storage Technologies

PRIMARY FUEL ENERGY STORAGE

Natural Gas Storage

One doesn't normally think of natural gas storage in the context of energy storage; however, the network of natural gas pipelines has much in common with the electric transmission network. A constant pressure in the pipelines must be maintained, and supply into the system must balance the removal of gas at industrial facilities, power plants, and local distributors like the City of Palo Alto Utilities (CPAU). Natural gas storage facilities can be thought of as a battery for the natural gas system – when demand is low the storage is charged, and when demand is high the storage is discharged. In this way, natural gas storage can mitigate circumstances where gas production is mismatched with demand. In 2010, the US had over 8.7 trillion cubic feet of natural gas storage capacity, which is nearly 4% of annual natural gas consumption.⁶

⁴ Energy Storage for Power Grids and Electric Transportation: A Technology Assessment. P. Parfomak, Congressional Research Service Document 7-5700. March 27, 2012.

⁵ Market Evaluation for Energy Storage in the United States, Kema Inc. 2012.

⁶ http://www.eia.gov/dnav/ng/ng_stor_cap_dc_u_nus_a.htm and http://www.eia.gov/dnav/ng/ng_cons_sum_dc_u_nus_a.htm

Similarly, most coal-fired power plants have a stockpile of coal that would allow the plant to operate one to two months.⁷

When viewed in the context of electricity production, natural gas storage is not unlike conventional hydroelectricity. Stored natural gas is analogous to the water behind a dam, and the generators in a gas plant are turned by a gas combustion powered turbine rather than a water powered turbine. Of course, the environmental impacts of these two generating facilities are very different.

Concentrated Solar Power Molten Salt Tanks

Concentrating Solar Power (CSP) facilities have much in common with conventional natural gas and coal power plants: they all use heat to make steam which runs a turbine to turn a generator. CSP uses mirrors to concentrate sunlight on a receiver containing a fluid – either a high-temperature oil or a molten salt. The fluid, once heated via the concentrated sunlight, is then used to make steam.

As with natural gas or coal plants, the energy source used to run a CSP plant – very hot fluid – can be stored. By charging and discharging hot fluid stored in an insulated tank, these facilities are able to manage an imbalance of energy supply (from the sun) with energy demand (from the grid). The tanks can be sized to enable the plant to maintain its output for a short period – say 30 minutes of cloud cover – or even many hours after the sun has set.

Several large thermal energy storage systems for CSP are under construction, including the 250 MW Solana facility with 6 hours of storage in Arizona. When this project begins operation in 2013, CSP thermal energy storage will likely be second only to pumped hydro in capacity connected to the U.S. electric grid.⁸

ELECTRICAL ENERGY STORAGE

Batteries

A simple rechargeable battery may be the first energy storage device that comes to mind; indeed electric batteries were invented about 100 years before the modern electric grid took shape. Batteries take advantage of reversible chemical reactions to store and release electrical energy. When discharging, a reaction which generates a flow of electrons (i.e. electrical current) converts chemical energy to electrical energy. This reaction is reversed during charging.

The common lead-acid battery provides a good example of typical battery construction and operation. Two metal plates, a negative plate (anode) made of lead and a positive plate (cathode) made of lead oxide, are surrounded by a sulfuric acid solution. This solution is an electrolyte, that is, it contains free ions. At the negative plate, the electrolyte causes an

⁷ <http://www.eia.gov/todayinenergy/detail.cfm?id=6490>

⁸ http://www.abengoasolar.com/corp/web/en/nuestras_plantas/plantas_en_construccion/estados_unidos/ and Market Evaluation for Energy Storage in the United States, Kema Inc. 2012.

oxidation reaction which frees electrons giving it a negative charge. At the positive plate, the electrolyte causes a reduction reaction which needs free electrons to occur, giving it a positive charge.

If the positive and negative plates are connected, electrons will flow from the negative plate, where there are excess free electrons, to the positive plate, where there is a need for electrons. This electrical current can then be used to supply power to an electric load such as a light bulb (i.e. to do work). These reactions will continue until the electrolyte is depleted, at which point the battery is fully discharged.

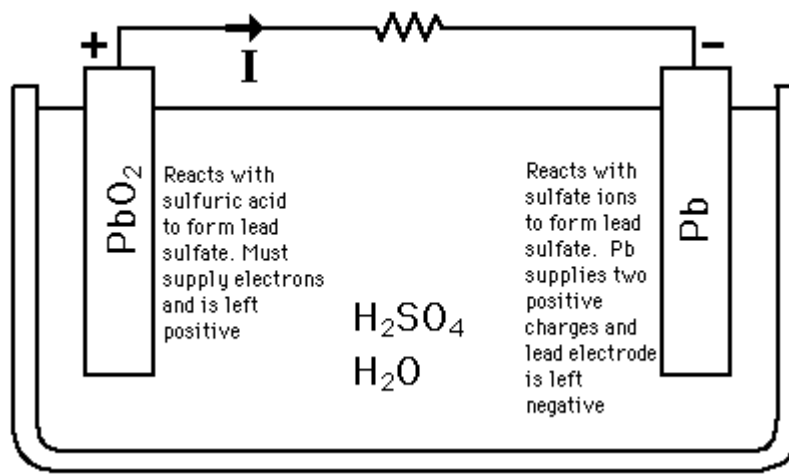

Figure C1: Lead Acid Battery Reactions⁹

In order to recharge the battery, a current is applied in the opposite direction, and the chemical reactions are reversed: electrons are supplied to the negative plate while they are removed from the positive plate. This recharging process continues until the electrolyte is fully restored to its original state, at which point the battery is recharged and ready to provide a supply electric power once again.

⁹ <http://hyperphysics.phy-astr.gsu.edu/hbase/electric/leadacid.html>

The strength with which electrons are repulsed from the anode and attracted to the cathode determines the voltage at which the battery operates. A common 12 volt lead-acid car battery has six such pairs of positive and negative plates, each contributing 2 volts. Typical battery construction is illustrated in the figure below.

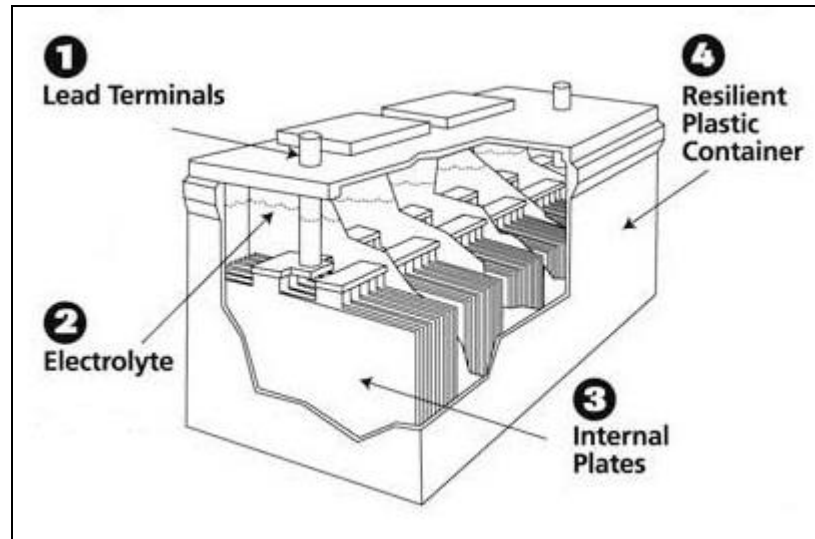

Figure C2: Lead Acid Battery Construction¹⁰

Most other batteries are variations on this simple design using different materials, each with its own advantages and disadvantages. Cost, energy density, and battery life are typically the most important performance characteristics. Other characteristics that vary for different battery types include performance degradation at high or low temperatures, charge retention, and toxicity levels. Lead-acid batteries use inexpensive and recyclable materials, yet their lead is heavy and toxic, and they degrade quickly when subject to deep discharging.

The other batteries described below seek to improve upon these two primary disadvantages of lead-acid batteries – energy density and short cycle life. The major battery technologies are summarized in the table below.

Type	Chemistry	Notes
Lead-Acid	Lead anode/Sulfuric acid electrolyte/ Lead-oxide Cathode	Mature technology, highly recyclable
Nickel	cadmium (Ni-Cd) or metal alloy (NiMH) anode/Ni-based cathode/potassium hydroxide electrolyte	Phased out due to toxicity of Cadmium
Li-ion	carbon-based anode/lithium salt based electrolyte/ various metal compounds for cathode	Mature
Na-S	molten sodium anode/ solid ceramic beta-alumina electrolyte/liquid sulfur cathode	Operates near 600° F. Production temp. halted for redesign due to fire risk ¹¹

Table C2: Battery Technologies

¹⁰ http://www.thebatterybank.co.uk/page_1283687216680.html

¹¹ http://www.ngk.co.jp/english/announce/111031_nas.html

Flow batteries are distinguished from the batteries described above in that the electrolyte is stored separately from the cell or cells where the reactions occur. As electrolyte in the reaction chamber is depleted during discharge it is continually replaced with an incoming flow of electrolyte. A similar process uses electrolyte flow to recharge the battery. One advantage of this type of system is that it enables the amount of energy storage (kWh), which is determined by the amount of electrolyte, to be sized independently from the power output of the battery (kW), which is determined by the size and number of reaction cells. While several demonstration systems have been installed, realistic cost and performance data is not yet available for flow batteries.

Capacitors

A capacitor is an energy storage device which stores energy in the electric field which develops between two statically charged plates that are separated by an insulator. A current applied to a capacitor will “charge” the capacitor by causing electrons to build up on one plate and to be driven away from the other plate, resulting in a static charge imbalance between the two plates. If the charging current is removed, current will flow in the opposite direction as electrons are driven away from the negative plate and return to the positive plate. As the capacitor discharges, static charge imbalance decreases between the plates, resulting in a decreasing voltage. The capacitor is completely discharged when there is no longer a static charge imbalance between the plates and the voltage reaches zero.

The primary advantages of capacitors are a result of the fact that, unlike batteries, charging and discharging does not involve a chemical reaction taking place on the surface of the plates. This results in a much higher cycle life, and also allows capacitors to be charged and discharged at a much faster rate than batteries, producing very high power; however, capacitors are unable to store as much energy as a battery, thus they can deliver power only for very short periods. Capacitors have been integrated with battery storage systems so that the capacitor is used when frequent or rapid charge/discharge is required, while the battery is used for longer-term needs. For example, an uninterruptible power supply may use capacitors to respond to sub-second interruptions, while the battery is deployed if an interruption lasts longer.¹²

SMES

Similar to capacitors, superconducting magnetic energy storage (SMES) devices are characterized by an ability to repeatedly and rapidly deliver very high levels of power, but only for several seconds. Rather than storing energy in the electric field generated by stationary electrons as in a capacitor, a SMES device stores energy in the magnetic field generated by moving electrons. The SMES is charged by inducing a DC current in a closed coil of superconductive wire. With their very low resistance, these wires can maintain a very high current, and thus a very strong magnetic field, with little loss. When discharging, this current is applied to a capacitor, creating a DC voltage.¹²

¹² http://www.energy.ca.gov/distgen/equipment/energy_storage/energy_storage.html

SMES devices have only been deployed in demonstration projects and are more expensive than batteries and capacitors, mainly due to costs of the superconducting coil and the auxiliary devices needed to keep it a low temperature—as low as -450° F—needed to achieve superconductivity. Researchers are looking for ways to achieve higher temperature operation.

NON-ELECTRICAL ENERGY STORAGE FOR RECONVERSION TO ELECTRICAL ENERGY

Pumped hydro

Like conventional hydro, pumped hydro, stores the potential energy of water in a reservoir at a high elevation and discharges by allowing the water to flow through a turbine; however, as the name implies, pumped hydro uses pumps (which consume electricity) to move water to a high elevation rather than the natural hydrologic cycle. By using electricity to run the pumps, pumped hydro is directly analogous to a battery—it converts electrical energy into potential energy when charging, and then reverses the process to generate electricity when “discharging.”

Pumped hydro facilities are much larger and generally more economical than any other energy storage device available today. As a result the vast majority of current grid connected energy storage is pumped hydro, some 500 MW, in the U.S.

CAES

Compressed Air Energy Storage (CAES) takes advantage of the same type of underground caverns that are often used for natural gas storage. In CAES, electricity is consumed by compressors which are used to fill the cavern with high pressure air. When discharging, this pressurized air is mixed with natural gas and used to power a turbine. The primary difference between CAES and conventional gas-fired combustion turbines is that the compression stage is performed independently, enabling this part of the process to occur when the turbine is not operating. CAES facilities can be easily scaled and are able ramp output very quickly, enabling them to provide load following and load leveling and to help mitigate high ramp events resulting from variability in generation from renewable resources (e.g. wind and solar).

Because natural gas is consumed during the discharge process, CAES is a hybrid storage/generation technology. To produce 1 kWh of electricity a CAES typically requires 0.6 to 0.8 kWh of input to power the compressors and 3,900 to 4,400 Btu (1.1 to 1.2 kWh) of natural gas. Since CAES is based on very well established technology, it can be a very cost effective energy storage option when inexpensive electricity is used to pressurize the cavern and cheap natural gas is used to “discharge” the system. While only one 110 MW CAES facility exists in the U.S., many are in planning stages. Current projects seek to use a wider variety of storage formations, while other projects are exploring ways to eliminate or reduce the need for natural gas.

Hydrogen

A variety of processes using either electricity or fossil fuels can be used to produce hydrogen, which can then be stored in tanks or geologic formations much like natural gas. The stored

hydrogen can then be consumed, typically in a fuel cell, to generate electricity. While much of the associated technology is mature, the round trip efficiency of the entire process is less than 50%. Other hurdles to hydrogen energy storage include expensive material requirements and the low density of hydrogen gas, requiring large storage volumes or very high compression of the gas to store large amounts of energy.

Sizing of hydrogen system components is very flexible, and hydrogen storage can be used in a variety of applications, from vehicle-scale to grid-scale systems. One grid-level hydrogen demonstration project on a remote Canadian island uses excess wind energy to generate hydrogen for later use, enabling wind power to replace much more of the island's diesel-based power than otherwise possible.¹³

Flywheel

The flywheel many are most likely familiar with—the large metal disk attached to an engine output shaft—can be thought of as an energy storage device. It “charges” when a firing cylinder forces the flywheel around and “discharges” as its rotational inertia keeps the crankshaft rotating in between the engine's power strokes. This ability to smooth the supply and demand of energy is a primary function of energy storage in the electric power system as well.

Several recent demonstration projects have shown that flywheels can be used effectively to help balance the electrical grid. In these devices, an electric motor speeds up a large flywheel when charging. Thanks to low friction bearings, the kinetic energy of the rotating flywheel can be maintained for long periods with minimal losses. When discharging, the motor becomes a generator, converting the flywheel's kinetic energy back to electricity as it slows the wheel.

Flywheels can be very rapidly charged and discharged repeatedly without causing any damage; however, they do not have a very high energy density. Thus, like capacitors, they can very quickly deliver a high power, but only for a brief period of time. This makes them ideal for supplying the quick, short bursts of power delivery and consumption that are necessary for regulating grid frequency. While flywheels have some advantages over batteries and capacitors in terms of lifetime reliability and material toxicity and availability, it remains to be seen whether they will be cost competitive.

NON-ELECTRICAL ENERGY STORAGE FOR DIRECT USE

Thermal Energy Storage

As described in Attachment C, there can be benefits to storing energy at the utility customer's site. Customers can store electrical energy using batteries, for instance, but energy can also be stored in other useful forms for use at a future time. In fact, the most common technology for customer-sited energy storage¹⁴ converts electrical energy to thermal energy, which is stored

¹³ <http://canmetenergy.nrcan.gc.ca/renewables/wind/464>

¹⁴ Market Evaluation for Energy Storage in the United States, Kema Inc. 2012

by cooling a large amount of material, typically water.¹⁵ This cold water is maintained at the desired temperature in an insulated container until it is used at a later time to provide cooling for a building or industrial process.

Thermal energy storage (TES) for heating and cooling looks much like thermal energy storage for future electricity generation using CSP as described previously. However, the thermal energy stored in thermal energy in heating and cooling applications is created by consuming electricity at a customer site, where it is used directly to offset electricity consumption at a later time. By avoiding the conversion of energy from electricity to some storage medium and then back to electricity, both of these forms of energy storage are highly efficient.

The common refrigerator and water heater are, in essence, thermal energy storage systems. Consider the water coming out of your shower head each morning. Typically that water is coming from the hot water tank, and was actually heated by the electric element or gas burner at some point before you turned on the shower. In other words, the water heater converted gas or electricity to thermal energy in the hot water storage tank, and you used that stored energy when you called for hot water. Refrigerators can also be considered an energy storage device: it is charging when the compressor is on and discharging when sitting idle.

Today the vast majority of these appliances are not controlled in a way that takes advantage of the services that energy storage can offer, such as peak load shifting, demand response, or frequency regulation; however, smart meter-enabled water heaters that can shift water heating electricity consumption to off-peak times have been available for several years, and energy storage appliances such as water heaters and refrigerators that can also automatically provide demand response or frequency regulation services are under development. Large commercial refrigeration facilities can be operated in “thermal freewheeling” mode where the unit is cooled below its setpoint and then turned off for a period in response to high energy prices or a demand response signal.

In commercial buildings, large TES systems can be used to provide space cooling, typically by cooling a volume of water with a chiller, a device using the same vapor compression cycle as a refrigerator. The water may be cooled to near freezing, or in ice storage systems, the water is actually frozen. Ice storage systems take advantage of water’s latent heat of fusion, which gives them 3 to 9 times greater energy storage density than a chilled water system¹⁶. Other TES systems use a thermal storage medium other than water, which freezes at a higher temperature, yielding energy storage densities between that of chilled water and ice.

These systems are operated such that the chiller is run at night, taking advantage of off-peak electricity to chill or freeze water. The cold storage medium is then used during the day to

¹⁵ Thermal energy is characterized by a difference in temperature just like potential energy is characterized by a difference in height. Both forms of energy can be used to perform work.

¹⁶ Buildings on Ice: making the Case for Thermal Energy Storage. W. Wilson, Environmental Building News. July, 2009

provide air conditioning instead of using peak electricity to run the building's air conditioning system. TES systems can be designed to provide up to 100% of the building's cooling load during the peak period.

Whether TES provides all or part of the building's cooling load, it enables significant amounts of electric load to be shifted from peak to off peak hours of the day. TES systems which shift only part of a building's cooling load have the added benefit of requiring a smaller chiller or allowing more efficient use of existing chillers.

TES systems can also be used to shift heating electricity load. Small residential electric storage heaters which warm bricks overnight for use during the day have been used for many years in the UK to shift heating load and take advantage of time of use rates. In the U.S. this is less common as electricity is not typically used for building heating and winter peaks are less severe.

Other thermal energy storage systems may use large areas of the earth or groundwater as the storage medium. Ground source heat pumps, for example, store heat in the ground over the summer, and pull heat out of the ground during winter. Such Underground Thermal Energy Storage (UTES) is being explored today for seasonal load shifting as well as shorter timescale energy storage cycles.

UNCONVENTIONAL "ENERGY STORAGE"

Conventional Hydro

Conventional hydropower is not an energy storage technology as typically conceived, because it is not "charged" using a part of the engineered energy system such as a conventional fuel or electricity. Rather, hydropower is "charged" by the natural hydrologic cycle depositing rainwater on elevated terrain. In conventional hydropower facilities this elevated water is stored behind a dam, and when power is needed, the water is allowed to flow through a turbine that turns a generator. The stored potential energy of elevated water is thus converted into electricity.

Clearly, conventional hydropower has many characteristics in common with energy storage devices: the size of the reservoir behind the dam is analogous to stored electrolyte in a flow battery or the geologic cavern in a CAES – it determines the quantity of energy (kWh) that can be stored. The size and number of the turbines determines how much power (kW) can be delivered at any given time. Conventional hydro is not able to perform load shifting as other energy storage technologies do, but it does have the ability to deliver significant amounts of power very quickly. With this high ramp rate, conventional hydroelectric facilities can provide many of the other services that energy storage provides, such as reserves, frequency regulation and mitigation of the intermittency of renewable power. In fact the Calaveras Hydro Facility, which is partly owned by Palo Alto, provides frequency regulation to the California Independent System Operator (CAISO) transmission grid and adequately covers CPAU's load serving obligations.

EV Batteries

While most battery energy storage installations are stationary, batteries can provide useful services to the electric power system wherever they are. And with the increasing use of electric vehicles (EVs), many have proposed using EV batteries to provide some benefit to the electric system while plugged in. This “Vehicle-to-Grid” technology could control EV charging so that it occurs at times that are beneficial to the grid, such as periods of excess wind generation or in the brief instances where the grid frequency is too high, providing frequency regulation services. Similarly, EV charging could be curtailed at times that are potentially harmful, such as during a demand response event. Some even propose using EVs to supply power to the grid, although increasing the number of cycles for an EV battery could reduce its life. While the technical challenges of vehicle-to-grid technology may not be great, controlling such a large number of distributed, customer-owned devices presents some operational and regulatory difficulty for grid operators

Time-shifting loads and Demand Response

These strategies look at the grid stability issue from the perspective of adjusting demand rather than supply. Electrical loads are commonly reduced on demand through demand response programs similar to the one begun in Palo Alto in 2011; however, enabling demand response to provide similar services to energy storage requires automation and quick response times. Loads can respond to a demand response signal by time-shifting energy use, for example, by adjusting the cycles of heating, cooling or refrigeration equipment, or by simply eliminating unnecessary loads such as escalators. The Demand Response program helped Palo Alto reduce customer summer peak loads by 600 kW in 2013.

ATTACHMENT D

ELECTRIC ENERGY STORAGE IN PALO ALTO

INTRODUCTION

This attachment describes the cost-effectiveness analysis for electric energy storage in Palo Alto. Thermal energy storage is analyzed separately in Attachment C because the applications and benefits of these two technologies are quite different.

This attachment reviews the various applications of electric energy storage and reviews the associated benefits. The value of each benefit is quantified and compared to the cost of a system which would provide those benefits at least cost. This attachment begins with an explanation of the larger electric power system and how it benefits from energy storage because many of the benefits, and hence value, of energy storage are associated with the stability of the larger electric power system.

THE MODERN ELECTRIC POWER SYSTEM

The electric grid, a network of high voltage transmission lines blanketing North America, makes up the backbone of our modern electric power system. For the most part, power is added to the system through large central power generating stations, and it is removed at substations from which power is fed out to local customers on a utility's distribution network. Generating stations and distribution substations exist throughout this network, but it can be helpful to illustrate the system in a linear fashion as below.

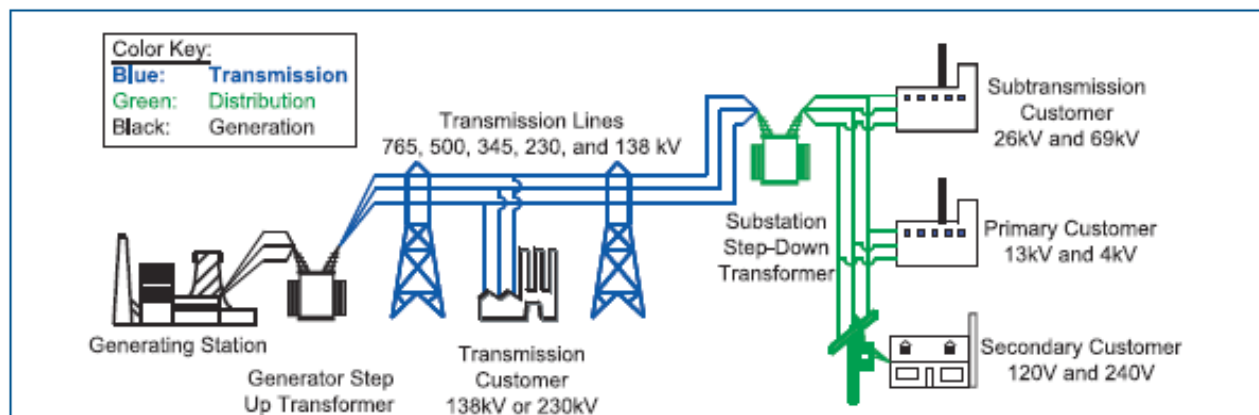

Figure D1: Electric Power System¹

The voltage and frequency of the electric grid must be maintained within a very narrow range to ensure that the electric devices that are connected to the system – both those that produce

¹ <http://www.ferc.gov/industries/electric/indus-act/reliability/blackout/ch1-3.pdf>

electric power and those that consume it – are able to operate. As a result, the consumption of energy by customers must be precisely balanced in real time with supply. Typically this balance is achieved by adjusting the output of fast-responding resources like hydropower to match the chaotic, short-term fluctuations in demand as devices are turned on and off and by keeping some generating capacity in reserve to ensure sufficient supply at all times, even if a large generator fails suddenly.

The California Independent System Operator (CAISO) coordinates this real-time balance of demand and supply in most of the state. Through CAISO markets, electric generators can provide services such as “regulation” or “spinning reserve” in addition to simply supplying electric energy. These services are needed to ensure instantaneous balancing electrical loads and generation to maintain system reliability.

Load following describes the process of generators providing power to meet the predictable variations in demand over a day, such as the “morning ramp” – an increase in load as customers start the day. This is a long-timescale service provided over a period of hours. At the other extreme is “frequency regulation”, a service that requires generators to adjust their output in a matter of seconds by automatic control to match the random and unpredictable variations in load as devices are turned on and off.

In Figure D2 below, the actual system load fluctuates randomly from minute to minute but is steadily rising on average. The overall supply of power slowly ramps as it follows the average load (load following), while the frequency regulation service (magnified) responds to this short time-scale fluctuation in actual load.

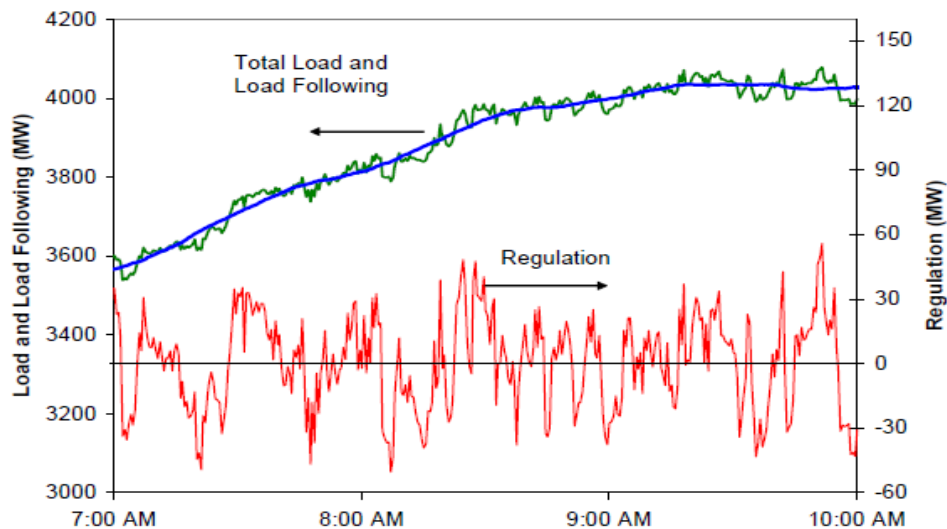

Figure D2: Load Following and Frequency Regulation²

² <http://www.ornl.gov/~webworks/cppr/y2001/rpt/122302.pdf>

Ancillary services are those that enable response to these unpredictable variations and events affecting the system. These services are delineated by the speed and duration with which the generator responds, as summarized in the table below.

Service	Service Description		
	<i>Response Speed</i>	<i>Duration</i>	<i>Cycle Time</i>
Regulation	Power sources online, on automatic generation control, that can respond rapidly to system-operator requests for up and down movements; used to track the minute-to-minute fluctuations in system load and to correct for unintended fluctuations in generator output to comply with Control Performance Standards (CPSs) 1 and 2 of the North American Reliability Council (NERC 2002)		
	<i>~1 min</i>	<i>Minutes</i>	<i>Minutes</i>
Spinning reserve	Power sources online, synchronized to the grid, that can increase output immediately in response to a major generator or transmission outage and can reach full output within 10 min to comply with NERC's Disturbance Control Standard (DCS)		
	<i>Seconds to <10 min</i>	<i>10 to 120 min</i>	<i>Days</i>
Supplemental reserve	Same as spinning reserve, but need not respond immediately; units can be offline but still must be capable of reaching full output within the required 10 min		
	<i><10 min</i>	<i>10 to 120 min</i>	<i>Days</i>
Replacement reserve	Same as supplemental reserve, but with a 30-min response time; used to restore spinning and supplemental reserves to their pre-contingency status		
	<i><30 min</i>	<i>2 hours</i>	<i>Days</i>
Voltage control	The injection or absorption of reactive power to maintain transmission-system voltages within required ranges		
	<i>Seconds</i>	<i>Seconds</i>	<i>Continuous</i>

Figure D3: Ancillary Services³

This delicate balancing act is made more difficult as total demand for electricity increases faster than the capacity to supply it reliably. During periods of peak load, when the demand is highest, older, less efficient and less reliable units must be called on while at the same time certain parts of the transmission or distribution system may approach their maximum carrying capacity.

Maintaining grid stability is also more difficult as more electricity is supplied by renewable sources. The output from most renewable energy technologies deployed today, namely wind and solar power, can fluctuate significantly within a very short period as difficult-to-predict changes in the weather occur.

In California, the need for generating capacity reserved for frequency regulation will grow from 419 MW in 2009 to 1,114 MW by 2020 due to increased variable generation sources needed to

³ <http://www.ornl.gov/~webworks/cppr/y2001/rpt/122302.pdf>

meet California’s renewable portfolio standard.⁴ In response to this need, the California Public Utilities Commission (CPUC) is currently revising its Resource Adequacy rules to incorporate requirements for utilities to purchase “flexible capacity” in much the same way that local capacity is required currently.⁵ With its ownership of the 54 MW share of the Calaveras Hydroelectric Project, Palo Alto has sufficient flexible generation capacity to meet load serving obligations on the grid.

THE NEED FOR ENERGY STORAGE

As the need for services that help balance electricity supply and demand is increasing, regulators and grid operators are looking to energy storage as a part of the solution. In very broad terms, energy storage systems absorb energy, store it for a period of time with minimal loss, and then release it. By charging and discharging energy, these systems facilitate the real-time balance between supply and demand, ensuring a stable electric grid.

The services that can be provided by energy storage depend fundamentally on how it performs: how much power it can supply (alternatively, how quickly it can charge and discharge), and the duration for which it can supply its rated power (Alternatively, the total amount of energy it can absorb). Hence, energy storage systems are rated both in units of power (watts, kW, or MW) and units of energy (watt-hours, kWh, or MWh).

A 10 kW battery with 5 hours of storage will be able to provide 10 kilowatts of power (enough to supply around 10 homes) and it will have a storage capacity of 50 kWh. A water storage tank is a helpful analogue: the size of the tank represents the amount of energy that can be stored (kWh), while the speed with which the tank can be filled or emptied represents the power rating (kW). A number of other parameters are used to characterize energy storage system performance: how many charge/discharge cycles they can perform before needing replacement (cycle life); how quickly they can reach a desired power level (ramp rate), and the amount of energy loss between charging and discharge (round-trip efficiency). Most of these parameters are also affected by temperature and system age.

The performance of an energy storage system determines the services it is able to provide. A system that can quickly ramp up but is unable to store large amounts of energy, such as a flywheel bank, will be very effective at managing short imbalances between supply and demand (e.g. frequency regulation). A less nimble system with far greater energy storage capacity, like a pumped hydro facility, can be very effective at mitigating peak demand problems by charging with off-peak energy and discharging during peak periods. Figure B4 below plots many different technologies on these two parameters – power and duration – and suggests the types of applications that are best matched with different energy storage system capabilities.

⁴ *ISO Study of Operational Requirements and Market Impacts at 33% RPS, Continued Discussion and Refinement of Step 1 and Step 2 Simulation Methodology. CAISO Slides presented at CPUC Renewable Integration Workshop on October 22, 2010*

⁵ <http://www.caiso.com/Documents/RevisedDraftFinalProposal-FlexibleCapacityProcurement.pdf>

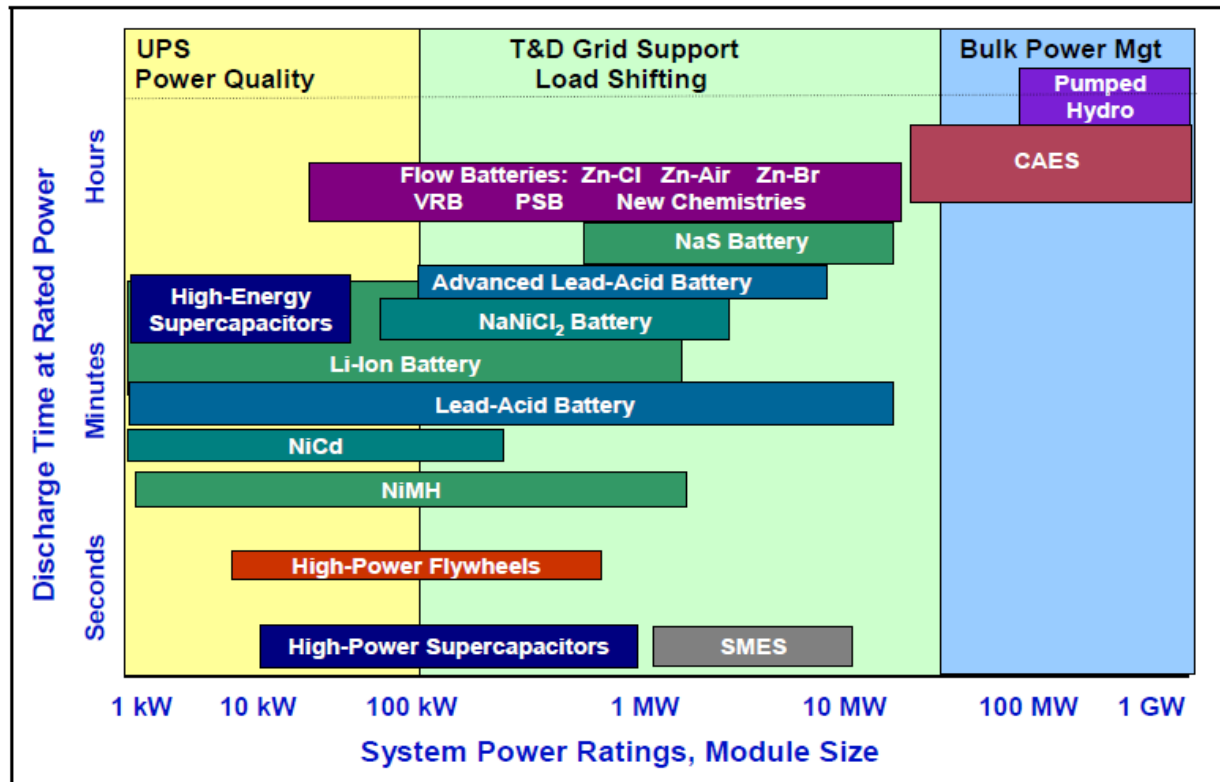

Figure D4: Performance of Several Energy Storage Technologies⁶

The location of an energy storage system within the electric power system will also determine the needs that the energy storage system can meet. For example, a large energy storage system sited at a solar plant could be used to smooth the plant's output by counteracting significant fluctuations due to changes in weather. This battery can do little to provide uninterrupted power to a utility customer who needs energy storage to ensure that critical systems are not affected by temporary service interruptions. Some energy storage technologies are limited in this regard: TES is limited to customer locations where heating or cooling is needed, for example. Others, such as batteries, can be deployed at a wide variety of scales and locations.

Figure B5 below summarizes energy storage applications at each point in the electric power delivery system. In California, larger energy storage systems on the utility-side of the meter can also participate in CAISO markets and provide a variety of market-based services, such as frequency regulation, as indicated.

⁶ Rastler D., Electricity Energy Storage Technical Options, EPRI Technical Update, December 2010.

Category	Storage 'End Use'
Describes at what point in the value chain storage is being used	Describes what storage is being used for, i.e. its application.
ISO/Market	1 Ancillary services: frequency regulation
	2 Ancillary services: spin/ non-spin/ replacement reserves
	3 Ancillary services: ramp
	4 Black start
	5 Real time energy balancing
	6 Energy price arbitrage
	7 Resource Adequacy
Generation	8 Intermittent resource integration: wind (ramp/voltage support)
	9 Intermittent resource integration: photovoltaic (time shift, voltage sag, rapid demand support)
	10 Supply firming
Transmission/ Distribution	11 Peak shaving
	12 Transmission peak capacity support (upgrade deferral)
	13 Transmission operation (short duration performance, inertia, system reliability)
	14 Transmission congestion relief
	15 Distribution peak capacity support (upgrade deferral)
	16 Distribution operation (voltage / VAR support)
Customer	17 Outage mitigation: micro-grid
	18 Time-of-use (TOU) energy cost management
	19 Power quality
	20 Back-up power

Figure D5 Energy Storage Benefits Based on Location⁷

Each service provides a different benefit to the system and each has a different value. In most cases, an energy storage system can be operated so that it provides more than one service or benefit.

⁷ (CPUC Energy Storage Proceeding R.10-12-007, Energy Storage Framework Staff Proposal, 4/3/2012)

Note that CAISO is responsible for ensuring grid stability. Thus the CAISO is responsible for procuring ancillary services needed to balance variable energy resources, such as wind power, used by Palo Alto. Palo Alto does not have to directly procure such services to balance the output from the resources that provide electricity to CPAU. The cost of ancillary services needed to balance the system is charged to Palo Alto by the CAISO and, at the same time, the CAISO provides credit for ancillary services provided by Palo Alto’s Calaveras hydro project to the transmission grid.

COST EFFECTIVENESS ANALYSIS

As suggested previously, the benefits associated with energy storage, and hence its value, depend on the application. The chart below summarizes benefits associated with different energy storage applications relevant to Palo Alto and considered in this analysis.

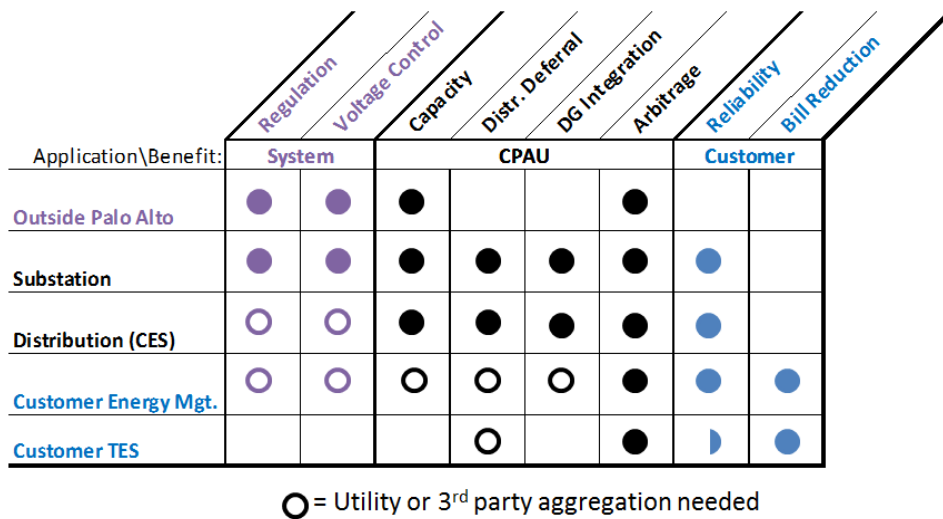

Figure D6: Energy Storage Applications and Benefits for Palo Alto

Each electrical energy storage application and benefit is described in detail below.

Outside Palo Alto refers to energy storage systems that Palo Alto may purchase or procure services from that are connected to the transmission grid outside of Palo Alto. These systems can provide system-wide benefits such as ancillary services like *frequency regulation* or *voltage control*, which are required by CAISO to maintain grid stability.

Energy storage systems can also be used to meet or offset Palo Alto’s requirements to purchase *capacity* in accordance with California’s resource adequacy rules. Grid connected energy storage systems can also be used to benefit Palo Alto by enabling energy price *arbitrage* – purchasing cheap energy, storing it, and using it during high price periods.

Substation refers to energy storage systems installed at a substation within Palo Alto. In addition to the benefits above, a local system can reduce loads on the distribution network, potentially enabling *deferral* of a distribution system upgrade. A mobile system may provide multiple deferrals.

Opportunities to use energy storage to avoid costly upgrades at the 9 CPAU substations were not found to exist currently for CPAU, and are unlikely in the near future based on 10-year load projections. Analysis of the loading of the 59 main feeder lines also resulted in the same conclusion. Hence, these potential benefits do not contribute to the value of energy storage systems in this analysis.

Local energy storage can also enable increased levels of distributed generation—*DG Integration*. In particular, energy storage can enable high levels of solar PV on a particular feeder by preventing instabilities that are associated with high levels of PV.⁸ This benefit helps Palo Alto meet its renewable energy goals with local solar power while maintaining system reliability. However, given available rooftop space, land use patterns and regulations in Palo Alto, a scenario where such instabilities arise is highly unlikely in the next 5-10 years.

A substation based storage system can also be used in the event of an outage to maintain service to certain customers who would otherwise experience an interruption. This *reliability* benefit also includes mitigation of momentary disruptions that would otherwise impact power quality.

For a city-owned and sited energy storage system to provide revenue through ancillary services, Palo Alto or a third party such as NCPA must provide the appropriate controls, communication capabilities, and certifications to participate in this CAISO market. There has been some interest by a Palo Alto based R&D organization to participate in a research project in this regard.

Distribution, also known as Community Energy Systems (CES), refers to small energy storage systems distributed along a feeder similar to the transformers that supply customers. As these systems are closer to the customer, they can provide even greater reliability improvements; however, smaller energy storage devices such as these would need to be controlled in aggregate to provide system-benefits such as *frequency regulation*.

Customer Energy Management refers to an application of energy storage on the customer side of the meter, which can be used strategically by the customer to *reduce electric utility bills* by shifting load from peak to off-peak, reducing peak demand charges and arbitraging energy costs, if on a time-of-use rate. A customer-sited system used in this way will also result in avoided costs for the utility by effectively performing price arbitrage for the utility as well.

⁸ Verschueren, T.; Mets, K.; Meersman, B.; Strobbe, M.; Develder, C.; Vandevelde, L.; , "Assessment and mitigation of voltage violations by solar panels in a residential distribution grid," *Smart Grid Communications*. (*SmartGridComm*), 2011 IEEE International Conference on , vol., no., pp.540-545, 17-20 Oct. 2011. <http://ieeexplore.ieee.org/stamp/stamp.jsp?tp=&arnumber=6102381&isnumber=6102296>

If Palo Alto is able to manage or direct customer-sited energy storage, it can potentially provide other local benefits such as enabling upgrade *deferrals*.

Customer TES refers to customer-sited thermal energy storage systems. As described in Attachment C, these systems shift cooling energy use, providing customer *bill savings*. Similarly, they provide *reliability*, but only for space cooling systems, as indicated by the half circle. If Palo Alto is able to target the deployment of TES systems to areas where a distribution upgrade would otherwise be necessary, it may enable an upgrade *deferral*.

Value of Utility-Owned Electrical Energy Storage

The cost-effectiveness analysis of utility-owned energy storage systems other than TES draws heavily upon a 2012 analysis done for SMUD by Electric Power Research Institute and Energy + Environmental Economics.⁹ Table B1 below summarizes the value associated with the various energy storage benefits described previously. Table B1 also includes the values assumed in the SMUD analysis alongside values for each benefit that are specific to Palo Alto. All energy storage benefits have the same or less value for Palo Alto except those accruing to the customer through bill savings.

Benefit	SMUD typical value	Palo Alto typical value
Frequency Regulation	\$11.60/MWh reg. up / \$8.38/MWh reg. down	Same (CAISO Market Value)
Voltage Control	\$1.05/kVAR	Same (CAISO Market Value)
Capacity	\$30/kW-year	\$21/kW-year
Distribution Deferral	\$100-\$158/kW-year (hypothetical)	\$0
Arbitrage	\$0.05 to \$0.30/kWh	\$0.02 to \$03/kWh
Reliability	\$0.10/kW to \$189/kW	Assumed Same
Bill Reduction	\$6.10/kW demand, \$0.01 to \$0.14/kWh shifted	\$20.11 - \$6.81/kW demand, \$0.014 to \$0.031/kWh shifted

Table D1: Comparison of Values of Energy Storage Benefits

Utility-Owned Electrical Energy Storage Cost-effectiveness

Based on the values associated with the benefits provided by energy storage, it is possible to estimate the net present value of an energy storage system. This analysis draws upon the SMUD study, which used an hourly model to maximize the value attained by energy storage systems in various applications over a 15 year anticipated lifetime.

The modeling results for SMUD indicate that the most valuable utility-owned energy storage systems were 1) a substation-sited 1 MW, 2-hour, transportable battery achieving multiple deferral benefits while also earning revenue through frequency regulation services, and 2)

⁹ *Benefit Analysis of Energy Storage: Case Study with Sacramento Municipal Utility District*. EPRI, Palo Alto, CA: 2011.1023591.

distributed energy storage systems controlled in aggregate to earn revenue through frequency regulation. The total present value per installed kWh for both scenarios is presented below using SMUD expected values for each type of benefit. (“Target” refers to the results using typical values; “High” refers to results using niche market values, 95th percentile and other maximum assumptions.)

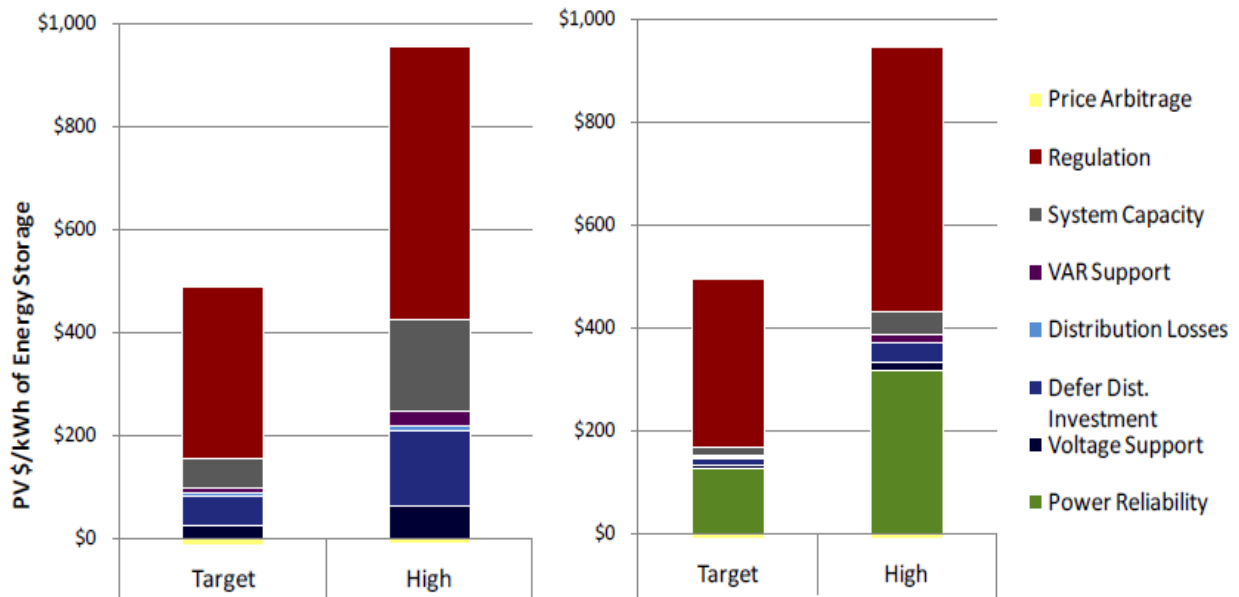

Figure D7: SMUD Present Value of Mobile Substation Battery & Aggregate Control CES¹⁰

The value of frequency regulation and power reliability are assumed to be the same for SMUD and Palo Alto; however, the values associated with other benefits of energy storage are significantly higher for SMUD than for Palo Alto. Given this information, it is estimated that the present value of these two high-value energy storage applications are approximately \$400/kWh.

Based on the cost information presented in the table below, the cheapest battery technology available today to deliver the services modeled above (1 MW, 2-hr) would cost approximately \$525/kWh, over 25% higher than the anticipated present value of the best-case energy storage applications presented above. This also does not include the costs associated with installation, developing the capability to sell frequency regulation in CAISO markets. Nor does it include costs associated with developing systems to manage distributed batteries in aggregate, which is needed to realize the value of frequency regulation for the Community Energy Storage scenario.

¹⁰ *Benefit Analysis of Energy Storage: Case Study with Sacramento Municipal Utility District*. EPRI, Palo Alto, CA: 2011. 1023591.

It is anticipated that the costs of energy storage will decrease with time – one report indicates that energy storage installed costs will approach \$500/kWh by 2022.¹¹ In this timeframe it is also anticipated that the energy storage industry will grow significantly.¹²

Technology	Cost	Cost of 1 MW, 2-hr system (Cost per kWh) – hardware only	Notes
Lead-Acid batteries	\$400/kW + \$330 per kWh	\$1,060,000 (\$530/kWh)	
Li-ion batteries	\$400/kW + \$600 per kWh	\$1,600,000 (\$800/kWh)	
Na-S batteries	\$350/kW + \$350 per kWh	\$1,050,000 (\$525/kWh)	Production temporarily halted due to fire concerns
Pumped Hydro	\$1,200/kW + \$75 per kWh	\$1,350,000 (\$675/kWh)	Not applicable for local installations
Thermal Energy Storage	\$500 - 1,000/kW for 6 hr.	N/A	Limited to cooling end uses, thus unable to provide many benefits included. See Attachment C.

Table D2: Energy Technology Summary

Given the results above, energy storage is clearly not cost effective for Palo Alto today; however, energy storage may be cost effective in the 5- to 10-year timeframe. In that time energy storage will likely play a more significant role in the electric power system; however, there is not currently a foreseeable need for energy storage for Palo Alto. There may be benefits to initiating an energy storage pilot project in Palo Alto, enabling CPAU to become familiar with the development and operation of energy storage in the event that a need or legislative mandate for energy storage does arise.

¹¹ https://portal.luxresearchinc.com/research/report_excerpt/10801

¹² For Example see <http://www.irena.org/DocumentDownloads/Publications/Electricity%20Storage%20-%20Technology%20Brief.pdf> and <http://www.pikeresearch.com/research/energy-storage-on-the-grid>

ATTACHMENT E

THERMAL ENERGY STORAGE IN PALO ALTO

Palo Alto Historical Thermal Energy Storage Incentive Program

In the late '80s and early '90s the City of Palo Alto Utility (CPAU) had a generous incentive program for thermal energy storage (TES) through its Partners Program for commercial customers. The program offered a rebate which varied year to year from \$250 to \$425 per kW of projected demand reduction, with caps ranging from \$100,000 to \$250,000 per project. A 50% cost share of feasibility studies, capped at \$5,000, was offered as well. Additionally, the commercial rate schedules were modified so that demand charges for customers with a TES system would only be based on their maximum demand from noon to 6 pm so that TES customers were not penalized for high demand leading up to the peak period. These TES incentives were motivated by steep and ratcheted demand charges imposed by PG&E on CPAU at that time.

At least seven commercial customers took advantage of the TES incentives: CPI; Loral; Roche (now VMware); Channing House; Varian; Lockheed; and Alza (now Wilson Sonsini). Currently, only two of those systems are known to still exist, Loral and VMware, and neither is being used to shift cooling load. Other systems have been dismantled or decommissioned due to failures, need for space, or presumably a lack of engaged operation and maintenance.

The **Loral TES system** serves Building #3 on the Loral campus and was designed to shift the entire peak period cooling load, enabling the chillers, condenser water pumps and cooling tower fans to be off between noon and 6 pm. The system was designed by Transphase Inc. and uses their encapsulated eutectic salt phase change system to provide 4,320 ton-hours of cooling energy storage in unpressurized below-ground tanks. The energy storage loop is a secondary water loop off of the original chilled water cooling loop which is fed by two parallel 400 ton chillers. A pressure-sustaining valve maintains pressure in the primary loop while two parallel pumps on the return side of the energy storage tanks inject water back into the primary loop. Flow in the two loops is decoupled by a normally open bypass.

The chillers were intended to charge the TES during the night and to cover any morning cooling requirements so that the entire storage capacity would be available during the 6-hour peak period. The Transphase operation manual recommends timing the charging cycle such that the final stages of charging would occur concurrent with morning cooling loads, ensuring that the chillers would not operate under inefficient, low-load conditions at this point. The chillers were intended to supply water at 42 F during the charging phase—cool enough to freeze the eutectic salt storage medium. During discharge, a storage inlet water temperature of 46 degrees or higher would begin to melt the storage medium and extract cooling capacity from the TES system.

The current Facilities Manager was involved in the original operation of the TES. In a recent conversation he recalled that the building temperature would creep up during the six-hour chiller lock out period, indicating either insufficient storage capacity or that the TES was not at full capacity at noon. The latter case could be due to insufficient charging time during off-peak periods or due to some discharge during prior to the peak period.

Sometime after the TES was installed, the primary function of Building # 3 changed from office to manufacturing, requiring constant temperatures 24 hours a day. At this time the chiller operation schedule was changed such that one of the chillers is on 24/7, and the second chiller is manually brought online when the operator is notified that indoor temperatures are too high. The cooling water flow is directed as originally designed, and the TES loop pumps are kept on to ensure that the storage loop and tank don't stagnate.

With only one chiller operating, its 42 degree supply water is mixed with return water resulting in a chilled water loop supply temperature of 46 degrees and return water temperature of 55 to 60 degrees. At these temperatures, the storage medium will not freeze; however the storage tanks do provide significant thermal inertia to keep CHW supply temperatures low during a temporary outage (highlighting another benefit TES systems can provide)

Based on meter data for the entire facility, the summer and winter peak loads are not significantly different, although major load cycling is observed during winter. The facility load typically peaks at around 4,000 kW between 2 and 5 pm. If the TES still has storage capacity, one option to more effectively use the system would be to shift some or all cooling load during this period to reduce demand charges. The TES could be charged by operating the second chiller for a several hours prior to 12 pm, then allowing some discharge while only one chiller is operating from 12 to 2, before locking out both chillers from 2pm to 5 pm. At minimum, such a strategy should be possible during winter.

The TES system at **VMware** is a more typical ice storage system: there is an independent ice storage loop with a chiller able to supply glycol at 22° F to two 17,000 gallon ice tanks. The water in the ice tanks is pumped through a heat exchanger to provide cooling to the building chilled water (CHW) loop during the discharge cycle. The glycol loop is also able to provide cooling to the building CHW loop directly through a separate heat exchanger.

The CHW loop is fed by three 400 ton centrifugal chillers, and when discharging, the TES was able to cool the return water enough to turn off the 3rd chiller under peak load conditions. This system had been used as designed from the initial commissioning in 1989 to 2009, when issues with the reliability of the system controls and increasing building loads caused VMware to stop using the TES for ice storage. Currently, the 150 ton glycol chiller is used to create 42 degree glycol which meets cooling loads directly via the glycol loop heat exchanger during low-load periods. Under high-load conditions, the glycol chiller is turned off, and a newer 800 ton chiller is brought online.

Thermal Energy Storage Modeling

Simple paybacks for several chiller-based TES systems are calculated below for a large commercial customer on both the standard and time of use rates. The TES is assumed to last for 20 years without major upgrades.

For simplicity it is assumed that cooling is required whenever the outside air temperature is 55° F or higher. It is also assumed that peak cooling loads will be required in any month where temperatures exceed 65° F. Table E1 below indicates the annual cooling hours based on temperature data for June 2009 through July 2012.

Time period	Annual Cooling Hours (base 55° F)
Summer Peak (12-6 p.m., M-F)	788
Summer Mid and Off-Peak	3,023
Winter Peak (8 a.m – 9 p.m, M-F)	877
Winter Off-Peak	543

Table E1: Annual Cooling Hours in Palo Alto

During these hours, it is assumed that a chiller would operate under 50% part load, on average. It is also assumed that the chiller has an efficiency of 0.7 kW/ton, a typical integrated part load value for centrifugal chillers. With these assumptions it is possible to approximate hourly chiller energy consumption over a year.

The first TES system analyzed is an incremental addition to an existing cooling system with a 400 ton chiller, and is designed to enable the chiller to be fully off from noon to 6 p.m. each day. The energy use associated with cooling during this period is then shifted from peak to off-peak period, under the assumption that the net roundtrip efficiency of the TES is 100% (see Attachment A). Under the TOU rate, this energy shift results in customer bill reductions; for customers on the standard rate it has no impact. It is also assumed that peak demand between noon and 6 p.m. is reduced by the full chiller electric load – 280 kW for a 400 ton chiller at 0.7 kW/ton—in any month where temperatures exceed 65° F.

The second analysis focuses on a partial storage TES system which meets the portion of the cooling load in excess of 200 tons from noon to 6 p.m. each day. By only meeting a portion of the load, a smaller TES system is used which can be charged by a smaller chiller during off-peak periods. Hence the partial storage TES enables capital cost savings if installed along with a smaller chiller. This analysis assumes that the chiller can be downsized from 400 to 200 tons and that 50% of the cooling energy from noon to 6 p.m. each day is shifted from peak to off peak. Peak load for demand charges are assumed to be reduced by 140 kW in any month where temperatures exceed 65° F.

Customer-Owned Thermal Energy Storage Cost Effectiveness

A standard rule of thumb cost for ice storage is \$100/ton-hour of storage capacity, so a typical six-hour TES system costs \$600/ton. With a chiller efficiency of 0.7 kW/ton this is equivalent to \$857/kW, which is consistent with a 2008 EPRI report that found ice storage installations cost between \$500 and \$1,000 per kW avoided.¹

For this analysis, the full storage system, requiring 2,400 ton-hours of storage, was assumed to cost \$240,000. The partial storage system, requiring 1,200 ton-hours of storage, was assumed to cost \$120,000; however, this system also enables a \$100,000 reduction in capital costs compared to a conventional chilled water system by enabling a chiller size reduction of 200 tons.² On net, the partial storage TES system cost is \$20,000.

Standard Rate

For customers on the standard large commercial rate, the primary benefit of a TES system is a reduction in demand charges. The demand charge used in this analysis is CPAU's current demand charge multiplied by 1.06 to account for projected increases in the total cost of energy over the 20-year system life.³ The standard demand and demand charge savings for the full and partial TES systems are summarized below.

	Monthly Demand Rates	Full Storage TES Annual Demand Savings	Partial Storage TES Annual Demand Savings
Summer	\$20.11/kW	\$34,000/yr.	\$17,000/yr.
Winter	\$12.23/kW	\$17,000/yr.	\$8,500/yr.
Total:		\$51,000/yr.	\$25,500/yr.

Table E2: TES Annual Savings – Standard Rate

In addition to the standard rate demand charge savings, customers with TES also benefit from increased reliability of the cooling system because a TES is less susceptible to performance degradation under high temperature conditions. No good documentation of the value of this benefit could be found for this analysis, however, and it is not included.

For customers on CPAU's standard large commercial rate, this analysis finds that a full storage TES system costing \$240,000 and saving \$51,000 per year has a simple payback of 4.7 years. A partial storage TES system with a net installed cost of \$20,000 and saving \$25,500 per year has a simple payback of less than one year under the same rate.

¹ Electric Power Research Institute (EPRI), "Thermal Energy Storage Technology Brief," No. 1016084, Palo Alto, CA, November 2008.

² Centrifugal chiller costs from the following site were used with adjustments for inflation:
<http://smud.apogee.net/comsuite/content/ces/?utilid=smud&id=1084>

³ This factor is based on current 20 year energy cost projections for Palo Alto

Time-of-Use (TOU) Rate

For customers on CPAU's large commercial TOU rate, a TES system also delivers bill savings by shifting energy consumption from high-price periods to low-price periods. However, TOU demand rates are significantly lower under the TOU rate, resulting in lower savings overall when compared to the standard rate. The table below summarizes the avoided demand and energy charges and annual savings for customers with a full storage and partial storage TES system on the TOU rate.

	Demand Rate	Full Storage TES Demand Charge Savings	Partial Storage TES Demand Charge Savings
Summer	\$13.24/kW	\$22,000/yr.	\$11,000/yr.
Winter	\$6.81/kW	\$9,500/yr.	\$5,000/yr.
	On vs. Off-peak Energy Rate Differential	Energy Charge Savings	Energy Charge Savings
Summer	\$0.03061/kWh	\$3,400/yr.	\$1,700/yr.
Winter	\$0.01409/kWh	\$1,700/yr.	\$860/yr.
	Total:	\$37,000/yr.	\$18,500/yr.

Table E3: TES Annual Savings – TOU rate

For customers on CPAU's large commercial TOU rate, this analysis finds that a full storage TES system costing \$240,000 and saving \$37,000 per year has a simple payback of 6.5 years. A partial storage TES system with a net installed cost of \$20,000 and saving \$18,500 per year has a simple payback of 1.1 years under the TOU rate. Again, no value is attributed to increased cooling reliability.

Value of Space

It is important to note that the costs used above do not include the value of space taken up by the TES system. An average space requirement, based on several common TES systems, is estimated at 0.6 square feet per ton-hour of storage capacity. The full storage TES system analyzed here is estimated to require 1,440 square feet—a substantial area.

Value of space will vary considerably from project to project, depending on other potential uses of the space. A very significant opportunity cost may be associated with certain potential TES spaces, such as parking spaces or storage. In a very simple sensitivity analysis, a hypothetical value of space was established at 50% of the average \$/square foot asking price for current commercial and industrial leases being offered in Palo Alto. Incorporating this cost into the analysis significantly impacted the results: the most cost effective system, a partial storage TES system under the standard rate, achieved a simple payback of 5.9 years as compared to less than one year without this cost.

Demand Response

A TES system could potentially be used to enable customers to participate in demand response (DR) curtailment events; however, under the current DR program, a TES system used for

demand response could not be used to shift load on a regular basis as demand response is measured as a deviation from the customer's typical usage. Under the best case this would earn the customer \$7,000/year in DR incentives – not enough to be cost effective.⁴

Alternatively, TES participants in DR could simply be given the \$7,000 incentive each year if the system is confirmed to be operational, under the assumption that the load shifting performed by the TES system is avoiding the need for an equivalent amount of demand response. This approach would require a real time confirmation that the system is operating and chillers are off during DR events via remote monitoring.

Incentives

An incentive for TES could be justified if the societal benefits of TES exceed the societal costs. Such an analysis is equivalent to the Total Resource Cost, or Societal, test, which is used to evaluate demand-side management (efficiency) programs. The societal benefits are the value of avoided costs to the City of Palo Alto due to the TES. By shifting load, a TES system enables CPAU to purchase less peak energy and capacity, resulting in the avoided costs summarized below.

Benefit	Value⁵	Full Storage TES Annual CPAU Avoided Cost	Partial Storage TES Annual CPAU Avoided Cost
Avoided Local Capacity Purchase ⁶	\$21/peak kW-yr.	\$6,000/yr.	\$3,000/yr.
Summer Energy shift from peak to off-peak ⁷	\$0.02654/kWh shifted	\$4,000/yr.	\$2,000/yr.
Winter Energy Shift from peak to off-peak ⁷	\$0.01720/kWh shifted	\$3,000/yr.	\$1,500/yr.
Total:		\$13,000/yr.	\$6,500/yr.
20 year Present Value:		\$176,000	\$88,000

Table E4: CPAU Avoided Costs

The societal cost for TES is simply the additional installed cost of equipment: \$240,000 for a full storage system and \$120,000 for a partial storage system or \$20,000 with capital cost savings included. Consequently, a full storage TES system has a societal benefit/cost ratio of 0.73. A partial storage TES system also has a societal benefit/cost ratio of 0.73, unless the partial storage system enables capital cost savings, in which case the ratio is 4.4.

⁴ Assuming 50 DR hours in a year with a payment of \$0.50/kWh, based on current CPAU DR program.

⁵ 20 year average values based on current CPAU avoided cost model. This table does not include any avoided system upgrade benefits.

⁶ The Local Resource Adequacy (LRA) benefit is 1/2 multiplied by a 20-year projected average of local capacity cost.

⁷ The energy cost differentials between peak and off-peak include 4.9% T&D losses as well as the projected 20-year average cost of energy, RPS premium and transmission access charges based on current voltage.

In both cases, however, the annual avoided cost for Palo Alto is 1/3 to 1/4 as large as the annual customer bill savings. Thus the load shifting achieved by TES results in a monetary transfer from other customers to the load shifting customer, and any incentive for load shifting would further this ratepayer impact. For this reason an incentive may not be justified.

Other utilities, including PG&E, are able to provide a ratepayer-neutral incentive due to avoided costs exceeding customer bill savings. An analysis conducted by for California's IOUs found that ratepayer-neutral incentives for TES could be justified because the IOU's avoided costs were higher than customer bill savings in some cases.⁸ In that analysis, a typical 6-hour TES would avoid approximately \$2,200 per kW of peak load reduction in present value. This same system would avoid only \$570/kW for Palo Alto.

TES Cost Effectiveness Results

The table below summarizes the customer cost effectiveness analysis of both full and partial storage TES under standard and TOU rates and also with a \$7,000/year DR incentive:

Scenario	System Cost	Annual Savings	Simple Payback
Full TES, Standard Rate	\$240,000	\$51,000	4.7 years
Full TES, Standard Rate + DR	\$240,000	\$58,000	4.1 years
Partial TES, Standard Rate	\$20,000	\$25,500	< 1 year
Partial TES Standard Rate + DR	\$20,000	\$32,500	< 1 year
Full TES, TOU Rate	\$240,000	\$37,000	6.5 years
Full TES, TOU Rate + DR	\$240,000	\$44,000	5.5 years
Partial TES, TOU Rate	\$20,000	\$18,500	1.1 years
Partial TES, TOU Rate + DR	\$20,000	\$25,500	< 1 year

Table E5: Customer Cost Effectiveness Summary

Utility-Owned and Operated Thermal Energy Storage

In recent years another model for deploying TES has emerged which is based on utility-ownership and control. This model reflects the fact that reliable load shifting is far more valuable to a capacity constrained utility than it is from a ratepayer's point of view. For utilities which are facing investments in distribution system upgrades or new generating capacity, a reliable reduction in peak loads can be incredibly valuable.

The utility-ownership model has been developed by Ice Energy, which makes packaged roof-top ice storage units that integrate with refrigerant-based (direct exchange, or DX) roof top units (RTUs) commonly found in commercial cooling applications.

The Ice Energy product, called Ice Bear, has a dedicated compressor for charging its ice storage unit overnight. When called on by the utility, the Ice Bear will shut down the RTU compressor

⁸ Energy + Environmental Economics and StrateGen. *Statewide Joint IOU Study of Permanent Load Shifting*. December 2010.

and condenser fans and provide cooling by sending ice-cooled refrigerant through a new evaporator coil placed in series with the RTU's existing coil. Ice Bears are designed to integrate with RTUs ranging from 4 to 20 tons of cooling capacity and are designed to replace the RTU for 6 hours. For example, an Ice Bear designed to integrate with a 5-ton RTU would have 5 tons of capacity with 30 ton-hours of ice storage. This distributed ice storage solution does not have the economies of scale inherent in larger, chiller-based TES systems; however, it benefits from a simple modular design.

After first attempting to sell Ice Bears directly to building owners, Ice Energy found that utility ownership was a more viable model. The utility contracts with Ice Energy to provide a certain amount of capacity displacement, and Ice Energy then delivers on the contract through a combination of Ice Bear installations, direct load control, and energy efficient upgrades for older RTUs. Direct load control (DLC) is achieved by using the Ice Bear controls to shut down certain other loads that have the appropriate communication capabilities (typically other RTUs that aren't compatible with the Ice Bear evaporator coil). The utility has control over the scheduling and operation of the Ice Bears and the other DLC loads through a web-based dashboard provided by Ice Energy.

A typical contract may stipulate 5 MW of load displacement. The first step of the program is to do a comprehensive survey of commercial customers to evaluate the potential for retrofits and Ice Bear installations. Generally 60% of the load reduction is achieved through permanent load shifting (PLS) using Ice Bears. Approximately 20% is achieved through DLC and approximately 20% through permanent load reduction due to RTU energy efficient upgrades. Customers participating in the program typically agree to a certain level of DLC, for example, a RTU compressor may be turned off for a maximum of 30 minutes twice a day.

Ice Energy has found that customers typically see 5-10% reductions in overall energy cost, but participation in the program is generally driven by the need to replace old equipment or the need for reliable cooling on the hottest days rather than energy savings. Ice Bears are installed free of charge, and replacement RTUs can be provided at a discount of 20 – 30%.

Typical Ice Energy costs under this model are provided in the table below. Note that the per-kW cost of the Ice Energy program is significantly higher than the typical \$500 - \$1,000/kW cost of chiller-based TES systems. Also note that these costs reflect a mix of PLS, DLC and energy efficiency.

Hard Costs	\$2,100/kW
Soft Costs (assessments, marketing, shipping, tax)	\$200/kW
Annual Maintenance and Operation Costs	\$60/kW-yr

Table E6: Ice Energy Costs

Based on an estimate of the number of roof top units in Palo Alto, a hypothetical Ice Energy project is described in the table below. For simplicity it is assumed that all RTUs are 5 ton

capacity with an actual efficiency of 1.3 kW/ton. As in the earlier analysis, it is assumed that an RTU will run at full capacity whenever the outside temperature is above 55 degrees.

Program Specifications	
Program Contract Capacity:	2,170 kW
Ice Bear / Permanent Load Shift (PLS) Contribution	1300 kW
Energy Efficiency (EE) Contribution	435 kW
Direct Load Control (DLC) Contribution	435 kW
Program Costs	
First Year Cost:	\$4,991,320
Annual Operating Cost:	\$130,210/yr.

Table E7: Ice Energy Program Costs⁹

The benefits provided by such a program vary considerably based on a utility’s marginal costs of peak capacity. For CPAU, the avoided costs are summarized table C4, while the annual benefit of such a program is summarized in TableC8 below. The capacity benefit is provided by the PLS, EE and DLC components of the program. Load shifting benefits are provided by the PLS component only. Energy reduction benefits (a permanent reduction in energy purchases) are provided by the EE component only.

Program Benefit	Annual Avoided Cost
Local Resource Adequacy Capacity:	\$46,000
Summer Load Shift:	\$33,000
Winter Load Shift:	\$5,000
Summer Peak Energy Reduction:	\$55,000
Summer Off-Peak Energy Reduction:	\$30,000
Winter Peak Energy Reduction:	\$12,000
Winter Off-Peak Energy Reduction:	\$50
Total Annual Benefit:	\$181,000

Table E8: Ice Energy Program Annual Benefit

Given the program’s first costs, annual operating cost, and annual avoided cost, assuming a program life of 20 years and a CPAU discount rate of 4%/year, the program has a net present value of -\$4,146,590 and a simple payback of 95 years.

Such a program would not be cost effective given CPAU’s current cost structure; however, a more targeted program could target a specific area of CPAU territory where peak load shifting could enable distribution system upgrades to be deferred. At present, no upgrade deferral opportunities are imminent or projected for five to ten years.

⁹ These are taken from an Ice Energy proposal to Arizona Public Service and a spreadsheet provided to CPAU by Ice Energy.

The table below summarizes the results for an Ice Energy system program if a hypothetical distribution system upgrade deferral opportunity existed. The project assumes a contracted load reduction capacity of 500 kW enabling a \$500,000¹⁰ system upgrade to be deferred for the 20-year life of the program.

Targeted Program Description	
Program Contract Capacity:	500 kW
First Year Cost:	\$1,150,000
Annual Operating Cost:	\$30,000/year
Program Benefits	
Annual Direct Savings	\$41,650
Avoided System Upgrade:	\$500,000
Program Cost Effectiveness	
Year 1 Cash flow	-\$608,350
Year 2-20 Cash flow	\$11,650/year
Program Simple Payback:	52 yrs
Program NPV:	-\$455,380

Table E9: Ice Energy Program Value with a Hypothetical Distribution System Upgrade Deferral

The hypothetical scenario described above is still not cost effective due to the city's current cost projections. The program doesn't reach a positive net present value until the cost of the avoided upgrade reaches nearly \$1,000,000.

With the very high costs of a program similar to that provided by Ice Energy and the low avoided costs for Palo Alto, this model for TES deployment is not viable. Even under a hypothetical scenario which captures an opportunity to defer a distribution system upgrade, such a program is not cost effective.

¹⁰ A distribution feeder replacement is typically in the hundreds of thousands.

ATTACHMENT F

ENERGY STORAGE REGULATION, POLICIES & INCENTIVES

Energy Storage Regulations and Policies

California's Energy Storage Law (hereinafter referred to as Assembly Bill (AB) 2514)¹ and the associated regulations are among many current policies designed to encourage energy storage. In October 2013 the California Public Utilities Commission (CPUC) established an energy storage target of 1,325 megawatts (MW) for the Investor-Owned Utilities (IOUs), including Pacific Gas and Electric Company, Southern California Edison, and San Diego Gas and Electric.² The CPUC Decision requires the IOUs to meet the 1,325 MW target by 2020, with installations required no later than the end of 2024.³ The CPUC decision also establishes a target for Community Choice Aggregators and electric service providers to procure energy storage equal to 1 percent of their annual 2020 peak load by 2020 with installation no later than 2024, consistent with the requirements for the IOUs⁴.

Laws promoting energy storage in New York and Texas have also been passed, although these do not specifically require energy storage targets. At the federal level, legislation that could provide a 20% investment tax credit for grid-connected energy storage systems and a 30% credit for behind-the-meter systems has been introduced.⁵

The Federal Energy Regulatory Commission (FERC) is also seeking to level the playing field for energy storage to participate in energy markets. In 2007 and 2008, FERC issued *Orders 890 and 719*, which opened the door for non-generation resources such as energy storage to participate in ancillary services markets. In response, the California Independent System Operator (CAISO) made changes to its ancillary services operating and technical requirements to enable these non-traditional resources to participate, such as reducing the minimum size and output duration capability for eligible resources.⁶

FERC recently enacted *Order 755* specifically addressing frequency regulation services. As described in Attachment A, some energy storage technologies are able to provide frequency regulation services more quickly and accurately than conventional generating facilities; however, markets for frequency regulation services typically do not differentiate between more effective regulation providers. FERC Order 755 attempts to rectify this by requiring appropriate "pay for performance" in organized ancillary services markets. A June 2012 FERC notice proposes rules to reduce other barriers that prevent energy storage facilities from participating

¹ AB 2514 (Chapter 469, Statutes of 2010).

² CPUC Decision 13-10-040 (<http://docs.cpuc.ca.gov/PublishedDocs/Published/G000/M079/K533/79533378.PDF>)

³ CPUC Decision 13-10-040 (<http://docs.cpuc.ca.gov/PublishedDocs/Published/G000/M079/K533/79533378.PDF>)

⁴ CPUC Decision 13-10-040 (<http://docs.cpuc.ca.gov/PublishedDocs/Published/G000/M079/K533/79533378.PDF>).

⁵ <http://info.a123systems.com/blog/bid/127815/STORAGE-Act-of-2012-What-it-Means-for-Grid-Energy-Storage>

⁶ 2020 Strategic Analysis of Energy Storage in California, 2011. Public Interest Energy Research for the CEC. CEC-500-2011-047.

in markets for ancillary services as well as imposing similar pay for performance requirements on transmission providers in traditionally regulated states.

Energy Storage Incentives and Investments in California

All of California's IOUs provide incentives to customers to reduce load during system-wide peak periods. Building owners who install energy storage systems that provide peak load reduction can receive these incentives. Commercial new construction⁷ and building retrofit⁸ programs provide a \$100/kW incentive for peak demand reduction while the California Advanced Homes Program provides a \$75-\$225/kW incentive for new residential buildings.⁹

In 2009, the CPUC ruled that California's IOUs must develop a Permanent Load Shift (PLS) program to encourage thermal energy storage (TES) directly. A statewide pilot PLS program from 2008-2011 provided \$500/kW of peak demand reduction. Based on a 2010 study of PLS benefits, the IOUs recently submitted a new PLS program proposal with the following incentive levels:¹⁰

Utility	Incentive Budget	Incentive Rate (Capped at 50% of project cost)
PG&E	\$13,500,000	\$360/kW
SCE	\$12,708,150	\$675/kW
SDG&E	\$2,235,000	\$513/kW

Table F1: IOU-proposed Incentives for PLS

This proposed IOU program imposes extensive rules on participants which restrict the eligible TES systems, require an hourly model of system performance by a Professional Engineer, lock participants in to a designated rate for 5 years, and require participants to instrument the system and submit quarterly reports to the utility demonstrating that it is operating as required by the program. Pushback from energy storage advocates may result in changes to the final program.

Customers of California's IOUs are also eligible for the *Self Generation Incentive Program* (SGIP), which was revised in 2011 to extend a \$2/Watt incentive to energy storage systems. Previously, this incentive had only been available for energy storage systems paired with an

⁷ <http://www.savingsbydesign.com/book/savings-design-online-program-handbook#booknode-435>

⁸ <http://www.pge.com/mybusiness/energysavingsrebates/rebatesincentives/ief/> and <http://www.aesc-inc.com/download/spc/2012SPCDocs/UnifiedManual/Customized%201.0%20Policy.pdf>

⁹ <http://www.californiaadvancedhomes.com/about-cahp>

¹⁰ 2012 – 2014 Statewide Permanent Load Shifting Program Proposal. Jointly submitted to CPUC by PG&E, SDG&E, SCE on July 30, 2012

eligible renewable energy generating system.¹¹ Only “advanced” energy storage technologies not eligible for other incentives qualify, however.¹²

California’s IOUs are also actively involved in energy storage project development. PG&E is in the early stages of developing pumped hydro and compressed air energy storage facilities, with the support of grants from the Department of Energy. Southern California Edison is developing a 32 MWh Li-ion battery to be installed at a Tehachapi Wind Resource Area substation to provide a number of grid-level services and demonstrate the effectiveness of energy storage for wind integration in a transmission-constrained area.¹³

Publicly Owned Utilities (POUs) are also active in promoting energy storage. SMUD offers an Air Conditioning Custom Incentive for commercial building peak load reduction of \$200/kW.¹⁴ Additionally, SMUD has received grants for energy storage demonstration projects, including a 500 kW/6-hr. battery at SMUD headquarters, and a series of distributed batteries serving the Anatolia Solar Smart Homes development.¹⁵ CPAU is too small to conduct research and development on its own and relies on the large IOUs and POUs for research on energy storage technologies. CPAU monitors these research efforts and follows technology development in the energy storage field.

The Los Angeles Department of Water and Power (LADWP), in 2010, announced a partnership with a Chinese battery manufacturer to install a 5-10 MW battery for power reliability and wind integration at the LADWP’s Tehachapi wind facility.⁹

A number of POUs have also developed programs around the Ice Energy model of thermal energy storage described in Attachment C. Redding Electric Utility has a 6 MW contract with Ice Energy while Southern California Public Power Authority (SCCPA) has contracted for 53 MW for its various members. One SCCPA member, the City of Burbank, also offers an \$800/kW TES incentive based on the Ice Energy system but any TES system is eligible; however, the incentive is capped at 25% of the project cost.

¹¹ <http://gigaom.com/cleantech/regulators-change-fuel-cell-incentives-how-that-affects-bloom-energy/>

¹² <http://docs.cpuc.ca.gov/Published/Graphics/165317.pdf>

¹³ 2020 Strategic Analysis of Energy Storage in California, 2011. Public Interest Energy Research for the CEC. CEC-500-2011-047.

¹⁴ <https://www.smud.org/en/business/save-energy/rebates-incentives-financing/incentives-for-heating-and-cooling/customized-incentives-air-conditioning.htm>

¹⁵ <https://www.smud.org/en/about-smud/news-media/news-releases/2012-06-29.htm> and <https://www.smud.org/en/about-smud/news-media/smud-updates/2012-06-01-housing-development-looks-to-the-future.htm>