



**SAMPLE FORM – NOT VALID FOR SUBMISSION TO BUILDING DEPARTMENTS**

**CERTIFICATE OF VERIFICATION**

**Note:** This table completed by HERS Registry.

Project Name:	Enforcement Agency:
Project Address:	Permit Number:
City and Zip Code:	Permit Application Date:

**A. System Information**

01	Space Conditioning System Identification or Name	
02	Space Conditioning System Location or Area Served	
03	Indoor Unit Name	
04	Verified Low Leakage Air-Handling Unit Credit	
05	Duct System Compliance Category	

**B. Duct Leakage Diagnostic Test - MCH-04c – Low Leakage Air-Handling Unit**

01	Condenser Nominal Cooling Capacity (ton)	
02	Heating Capacity (kBtu/h)	
03	Leakage Factor (Value must match the PRF-1)	
04	Air-Handling Unit Airflow (AHU Airflow) Determination Method	
05	Calculated Target Allowable Duct Leakage Rate (cfm25)	
06	Actual Duct Leakage Rate from Leakage Test Measurement (cfm25)	
07	Compliance Statement:	

**C. Additional Requirements for Compliance**

01	System was tested in its normal operation condition.	
02	All supply and return register boots sealed to the surrounding material.	
03	Cloth backed rubber adhesive duct tape may not be used as the primary air sealing method for duct connections.	
04	All connection points between the air handler and the supply and return plenums are completely sealed.	
05	The installed air handler must appear on the Commission's list of certified low leakage air handlers.	
06	Verification Status:	<ol style="list-style-type: none"> <li>1. <u>Pass</u> - all applicable requirements are met; or</li> <li>2. <u>Fail</u> - one or more applicable requirements are not met. Enter reason for failure in corrections notes field below; or</li> <li>3. <u>All N/A</u> - This entire table is not applicable</li> </ol>
07	Correction Notes:	

**The responsible person's signature on this compliance document affirms that all applicable requirements in this table have been met unless otherwise noted in the Verification Status and the Corrections Notes in this table.**

**D. Determination of HERS Verification Compliance**

All applicable sections of this document shall indicate compliance with the specified verification protocol requirements in order for this Certificate of Verification as a whole to be determined to be in compliance.

01	
----	--



SAMPLE FORM – NOT VALID FOR SUBMISSION TO BUILDING DEPARTMENTS

DOCUMENTATION AUTHOR'S DECLARATION STATEMENT

1. I certify that this Certificate of Verification documentation is accurate and complete.

Table with 2 columns: Documentation Author Name, Signature, Company, Date Signed, Address, CEA/HERS Certification Information, City/State/Zip, Phone.

RESPONSIBLE PERSON'S DECLARATION STATEMENT

2. I certify the following under penalty of perjury, under the laws of the State of California:

- 1. The information provided on this Certificate of Verification is true and correct.
2. I am the certified HERS Rater who performed the verification identified and reported on this Certificate of Verification (responsible rater).
3. The installed features, materials, components, manufactured devices, or system performance diagnostic results that require HERS verification identified on this Certificate of Verification comply with the applicable requirements in Reference Nonresidential Appendices NA1 and NA2, and the requirements specified on the Certificate of Compliance for the building approved by the enforcement agency.
4. The information reported on applicable sections of the Certificate(s) of Installation (NRCI), signed and submitted by the person(s) responsible for the construction or installation conforms to the requirements specified on the Certificate(s) of Compliance (NRCC) approved by the enforcement agency.
5. I understand that a registered copy of this Certificate of Verification shall be posted, or made available with the building permit(s) issued for the building, and made available to the enforcement agency for all applicable inspections, and I will take the necessary steps to accomplish this requirement.
6. I understand that a registered copy of this Certificate of Verification is required to be included with the documentation the builder provides to the building owner at occupancy, and I will take the necessary steps to accomplish this requirement.

BUILDER OR INSTALLER INFORMATION AS SHOWN ON THE CERTIFICATE OF INSTALLATION

Table with 2 columns: Company Name (Installing Subcontractor, General Contractor, or Builder/Owner), Responsible Builder or Installer Name, CSLB License.

HERS PROVIDER DATA REGISTRY INFORMATION

Table with 2 columns: Sample Group Number (if applicable), Dwelling Test Status in Sample Group (if applicable).

HERS RATER INFORMATION

Table with 2 columns: HERS Rater Company Name, Responsible Rater Name, Signature, Responsible Rater Certification Number w/ this HERS Provider, Date Signed.

For assistance or questions regarding the Energy Standards, contact the Energy Hotline at: 1-800-772-3300

CERTIFICATE OF VERIFICATION – USER INSTRUCTIONS	NRCV-MCH-04-H
Duct Leakage Diagnostic Test	(Page 1 of 3)

### NRCV-MCH-04a User Instructions

#### A. System Information

1. *HVAC System Identification or Name*: Provide an identification name or tag name that uniquely identifies the duct system. If there is a mechanical plan for the system, the tag name may be given on the plans.
2. *HVAC System Location or Area Served*: Provide a brief description of the area served by the duct system (e.g. upstairs; downstairs) to help distinguish one system from another in buildings with multiple systems.
3. *Indoor Unit Name*: Provide an identification name or tag name that uniquely identifies the indoor unit associated with this duct system. If there is a mechanical plan for the system, the tag name may be given on the plans.
4. *Verified Low Leakage Air-Handling Unit (VLLAHU) Credit*: Indicate whether or not VLLAHU is required per PRF-01. For prescriptive alterations (change outs), choose “no”.
5. *Duct System Compliance Category*: Choose from Completely New, Complete Replacement, or Alteration.
  - a. New: For new buildings with a new HVAC system or replacement of at least 75% of the duct system and up to 25% consisting of reused parts from the existing duct system (i.e. registers, grilles, boots, air handler, coil, plenums, duct material).
  - b. Alteration: For HVAC change outs or when the air handler, condensing unit of a split system, or cooling coil or any amount of duct is added to an existing system but does not constitute a new duct system.
  - c. Alteration using Smoke Test: For alterations that are unable to pass the leakage test and a smoke test is used to confirm that all accessible leaks have been sealed.

#### B. Duct Leakage Diagnostic Test - MCH-04a - Completely New Duct System

1. *Condenser Nominal Cooling Capacity (ton)*: Enter the condenser nominal cooling capacity, refer to the manufacturer documentation. Example: if manufacture lists air conditioner total nominal output of 60,000 Btu/h, the user would divide this number by 12,000 and enter 5. Tonnage may also be determined by the model number. 018 = 1.5 tons, 024 = 2 tons, 030 = 3 tons, etc.)
2. *Heating Capacity (kBtu/h)*: Enter the system heating capacity (output) in thousands Btu/h, refer to the manufacturer documentation. Example if manufacture lists furnace output of 90,000 Btu/h, the user would divide this number by 1,000 and enter 90.
3. *Leakage Factor*: Based on answers to questions A04 and A05 the leakage factor will be set at 0.06 (6% leakage).
4. *Air-Handling Unit Airflow (AHU Airflow) Determination Method*: User will select from the following options:
  - a. Cooling System Method: For systems with cooling, this selection must be made. The nominal air handler airflow shall be 400 CFM per nominal ton of condensing unit cooling capacity (See Section NA2.1.4.1 of the 2022 Nonresidential Appendices).
  - b. Heating System Method: For heating only systems this selection must be made. The nominal air handler airflow shall be 21.7 CFM per kBtu/hr of rated heating output capacity (See Section NA2.1.4.1 of the 2022 Nonresidential Appendices).

5. *Calculated Target Allowable Duct Leakage Rate (cfm)*: This value will be automatically calculated. For systems with cooling, the target allowable duct leakage rate will be the leakage factor multiplied by the nominal air handler airflow of 400 CFM per nominal ton of condensing unit cooling capacity. For heating only systems, the target allowable duct leakage rate will be the leakage factor multiplied by the nominal air handler airflow of 21.7 CFM per kBtu/h of rated heating output capacity.
6. *Actual Duct Leakage Rate from Leakage Test Measurement (cfm)*: User will input this value from actual measurements from leakage test.
7. *Compliance Statement*: If Actual Duct Leakage Rate from leakage test is less than or equal to Calculated Target Allowable Duct Leakage Rate, “System passes leakage test” will automatically populate. If not, “System fails leakage test” will automatically populate.

### C. Additional Requirements for Compliance

1. This must be a true statement (or not applicable) for the system to comply. The duct leakage test must be performed on the system while in its normal operating condition. Temporary taping of the supply registers, return grilles, outside air damper, outside air intake and economizers is allowed for the duct leakage test on non-residential buildings. Parts of the duct system may not be isolated for the test.
2. This must be a true statement (or not applicable) for the system to comply. For new systems and systems passing by the smoke test, all registers must be sealed to the air barrier when mounted in the air barrier. Note: T-bar ceiling is not an acceptable air barrier in newly constructed buildings. In existing buildings a T-bar ceiling might define the conditioned boundary (insulation sits on T-bar ceiling), but it would not be effective to seal the register to the T-bar ceiling (location A in the diagram below). In this situation it is recommended, but not required, that the conditioned boundary be modified so that the insulation is aligned with an appropriate air barrier. When using the smoke test to pass an existing system with registers mounted in a T-bar ceiling, the register should be sealed to the register boot (location B in the diagram below).

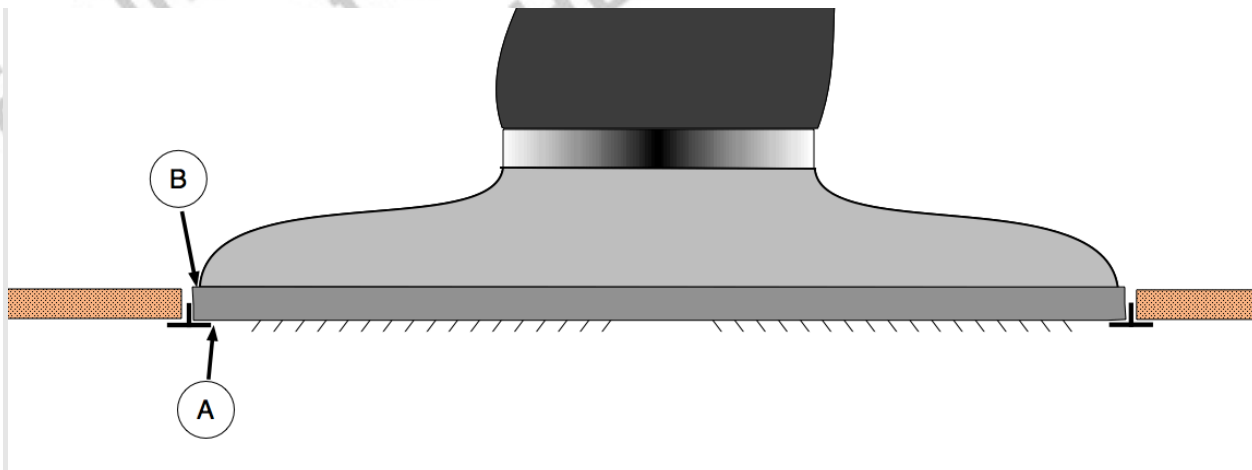

3. This must be a true statement (or not applicable) for the system to comply. Cloth back rubber adhesive duct tape (old style duct tape) does not meet the UL181 requirements for any new connections and may not be used as the primary method of sealing a duct connection. It may be used in conjunction with UL181

CERTIFICATE OF VERIFICATION – USER INSTRUCTIONS	NRCV-MCH-04-H
Duct Leakage Diagnostic Test	(Page 3 of 3)

rated mastic, draw bands, mesh, etc. on existing systems, it is recommended that old duct tape be covered with mastic to prevent further degradation. It is recommended that it not be used at all on new connections.

4. This must be a true statement (or not applicable) for the system to comply. All connection points between the supply and return plenums shall be completely sealed using approved materials. For newly installed equipment and systems passing by the smoke test, this is mandatory. On existing systems where the air handler and/or plenums have not been disconnected as part of the project these points do not need to be resealed as long as the system passes the 15% leakage rate; however, it is recommended that they be resealed with approved materials to prevent further degradation.
5. User to select one of the following:
  - a. Pass – select this when all of the additional requirements listed above have been met.
  - b. Fail – select this when one or more of the additional requirements listed above cannot be met. Use Row 6 to explain reason for non-compliance. Non-compliance must be corrected prior to passing.
  - c. All n/a – select this when **all** of the additional requirements listed above do not apply. This is not a common situation. Selecting this option may subject the project to additional scrutiny.
6. When “Fail” is selected in C05, use this row to explain why. Be as detailed as possible.

#### **D. Determination of HERS Verification Compliance**

1. When all requirements of Section B and Section C comply, “System Passes Leakage Test” will display here, otherwise “System Does not Comply” will display here and corrections will need to be made.

#### **Documentation Declaration Statements**

1. The person who prepared the NRCV will sign and complete the fields for their name, company (if applicable), address, phone number, certification information (if applicable), date and signature.
2. The person who is assuming responsibility for the project being built to comply with Title 24, Part 6, will complete the fields (if applicable) for their company, responsible builder or installer name, CSLB license number, sample group number, dwelling test status in sample group, HERS Rater company name, HERS Rater name, HERS Rater signature, HERS Rater certification number and date signed.