



**CALIFORNIA  
ENERGY COMMISSION**



**CALIFORNIA  
natural  
resources  
AGENCY**

Energy Research and Development Division

## **FINAL PROJECT REPORT**

# **Efficient and Zero Net Energy-Ready Plug Loads**

**Gavin Newsom, Governor  
September 2020 | CEC-500-2020-068**

**PREPARED BY:**

**Primary Authors:**

Alan Meier  
Richard Brown  
Daniel L. Gerber

Aditya Khandekar  
Margarita Kloss  
Hidemitsu Koyanagi

Richard Liou  
Leo Rainer  
Seth Sanders

Electronics, Lighting, and Networks Group  
Building Technology and Urban Systems Division  
Energy Technologies Area  
Lawrence Berkeley National Laboratory  
1 Cyclotron Road  
Berkeley CA 94720  
<http://www.lbl.gov>

**Contract Number:** EPC-15-024

**PREPARED FOR:**

California Energy Commission

Adel Suleiman

**Project Manager**

Virginia Lew

**Office Manager**

**ENERGY EFFICIENCY RESEARCH OFFICE**

Laurie ten Hope

**Deputy Director**

**ENERGY RESEARCH AND DEVELOPMENT DIVISION**

Drew Bohan

**Executive Director**

**DISCLAIMER**

This report was prepared as the result of work sponsored by the California Energy Commission. It does not necessarily represent the views of the Energy Commission, its employees, or the State of California. The Energy Commission, the State of California, its employees, contractors, and subcontractors make no warranty, express or implied, and assume no legal liability for the information in this report; nor does any party represent that the uses of this information will not infringe upon privately owned rights. This report has not been approved or disapproved by the California Energy Commission, nor has the California Energy Commission passed upon the accuracy or adequacy of the information in this report.

## **LEGAL NOTICE**

The Lawrence Berkeley National Laboratory is a national laboratory of the DOE managed by The Regents of the University of California for the U.S. Department of Energy under Contract Number DE-AC02-05CH11231. This report was prepared as an account of work sponsored by the Sponsor and pursuant to an M&O Contract with the United States Department of Energy (DOE). The Regents of the University of California, nor the DOE, nor the Sponsor, nor any of their employees, contractors, or subcontractors, makes any warranty, express or implied, or assumes any legal liability or responsibility for the accuracy, completeness, or usefulness of any information, apparatus, product, or process disclosed, or represents that its use would not infringe on privately owned rights. Reference herein to any specific commercial product, process, or service by trade name, trademark, manufacturer, or otherwise, does not necessarily constitute or imply its endorsement, recommendation, or favoring by The Regents of the University of California, or the DOE, or the Sponsor. The views and opinions of authors expressed herein do not necessarily state or reflect those of The Regents of the University of California, the DOE, or the Sponsor, or any of their employees, or the Government, or any agency thereof, or the State of California. This report has not been approved or disapproved by The Regents of the University of California, the DOE, or the Sponsor, nor has The Regents of the University of California, the DOE, or the Sponsor passed upon the accuracy or adequacy of the information in this report.

## **COPYRIGHT NOTICE**

This manuscript has been authored by authors at Lawrence Berkeley National Laboratory under Contract No. DE-AC02-05CH11231 with the U.S. Department of Energy. The U.S. Government retains, and the publisher, by accepting the article for publication, acknowledges, that the U.S. Government retains a non-exclusive, paid-up, irrevocable, world-wide license to publish or reproduce the published form of this manuscript, or allow others to do so, for U.S. Government purposes.

## **DISCLAIMER**

The government and the facility operator make no express or implied warranty as to the conditions of the research or any intellectual property, generated information, or product made or developed under this agreement, or the ownership, merchantability, or fitness for a particular purpose of the research or resulting product: that the goods, services, materials, products, processes, information, or data to be furnished hereunder will accomplish intended results or are safe for any purpose including the intended purpose; or that any of the above will not interfere with privately owned rights of others. Neither the government nor the facility operator shall be liable for special, consequential, or incidental damages attributed to such research or resulting product, intellectual property, generated information, or product made or delivered under this agreement.

# ACKNOWLEDGEMENTS

This work was supported by the California Energy Commission's Electric Program Investment Charge (EPIC) under Contract Number EPC-15-024, and the U.S. Department of Energy under Contract No. DE-AC02-05CH11231.

The California Energy Commission provided primary funding to make this project possible, and the authors would like to thank the following Energy Research and Development Division staff for providing their support and project stewardship:

- Laurie ten Hope, Deputy Director
- Virginia Lew, Office Manager
- Adel Suleiman, Project Manager, Senior Electrical Engineer
- Patrick Saxton, Senior Electrical Engineer, Appliance Standards Office

Many people were needed to create this report and particularly the devices it describes.

Thanks to project collaborators and partners:

- Delta Americas: M.S. Huang, Ravindra Nyamati, Mike Lin
- Belkin International: Omid Jahromi, Jack Norton
- Power Integrations: David Chen, Balu Balakrishnan, Doug Bailey

The Technical Advisory Committee: Katharine Kaplan, U.S. Environmental Protection Agency; Michael Lubliner, Washington State Energy Office; David Chen, Power Integrations; Ken Rider, California Energy Commission

Thanks to Program Managers Margarita Kloss and Laura Wong; also our administrative wizard, Paula Ashley.

Thanks, also, to reviewers for their generosity and time improving this report: Norman Bourassa, Michael Klopfer, Bruce Nordman, Steve Schmidt, and Vagelis Vossos.

## PREFACE

The California Energy Commission's (CEC) Energy Research and Development Division supports energy research and development programs to spur innovation in energy efficiency, renewable energy and advanced clean generation, energy-related environmental protection, energy transmission and distribution and transportation.

In 2012, the Electric Program Investment Charge (EPIC) was established by the California Public Utilities Commission to fund public investments in research to create and advance new energy solutions, foster regional innovation and bring ideas from the lab to the marketplace. The CEC and the state's three largest investor-owned utilities—Pacific Gas and Electric Company, San Diego Gas & Electric Company and Southern California Edison Company—were selected to administer the EPIC funds and advance novel technologies, tools, and strategies that provide benefits to their electric ratepayers.

The CEC is committed to ensuring public participation in its research and development programs that promote greater reliability, lower costs, and increase safety for the California electric ratepayer and include:

- Providing societal benefits.
- Reducing greenhouse gas emission in the electricity sector at the lowest possible cost.
- Supporting California's loading order to meet energy needs first with energy efficiency and demand response, next with renewable energy (distributed generation and utility scale), and finally with clean, conventional electricity supply.
- Supporting low-emission vehicles and transportation.
- Providing economic development.
- Using ratepayer funds efficiently.

*Efficient and Zero Net Energy-Ready Plug Loads* is the final report for the Efficient and ZNE-Ready Plug Loads project (Contract Number EPC-15-024), conducted by Lawrence Berkeley National Laboratory. The information from this project contributes to Energy Research and Development Division's EPIC Program.

For more information about the Energy Research and Development Division, please visit the [CEC's research website](http://www.energy.ca.gov/research/) (www.energy.ca.gov/research/) or contact the CEC at 916-327-1551.

# ABSTRACT

Plug loads are devices plugged into common electrical outlets. Modern buildings contain hundreds of these devices that when aggregated are responsible for at least 25 percent of electricity use in California buildings. The amount of electricity consumed by plug loads is increasing because the “Internet of Things” (a system of interrelated computed devices and machines that automatically transfer data over a network) is, to a great extent, the “Internet of Plug Loads.” This project developed technologies that will reduce the electricity consumption of plug loads. The project team investigated two crosscutting strategies in detail: (1) technologies to reduce standby power use to near zero, and (2) methods to increase the use of direct current as a power source. The researchers developed two new approaches to reduce standby to near zero that could apply to a wide range of devices. Prototype direct current appliances were developed to demonstrate electricity savings by bypassing power supplies and avoiding other losses. Networks of direct current-powered devices can save even more electricity and provide other benefits like resiliency during power outages. The project team also identified a unique category of electricity-using devices that provide life safety, health, and security to building occupants. The installation or use of devices in this category is dictated by building codes, health providers, insurance companies, and other entities—one of which would ordinarily prioritize energy efficiency. In the case of ground fault circuit interrupts, the project identified possible savings of 80 percent simply through adoption of the most efficient designs. Home medical equipment, particularly oxygen concentrators, is a rising category of electricity use where substantial savings are possible. This report also reviews the codes, standards, and other policies that affect electricity use of plug loads. **Keywords:** [Text](#)

**Keywords:** alarm, burst mode, circuit, commercial buildings, DC power, energy harvesting, GFCI, hard-wired, health, MELs, miscellaneous electrical loads, networks, oxygen concentrator, plug loads, residential buildings, safety, standby power, wake-up radio, CPAP

Please use the following citation for this report:

Meier, Alan, Richard Brown, Daniel L. Gerber, Aditya Khandekar, Margarita Kloss, Hidemitsu Koyanagi, Richard Liou, Leo Rainer, and Seth Sanders. 2020. *Efficient and Zero Net Energy-Ready Plug Loads*. California Energy Commission. Publication Number: CEC-500-2020-068.

# TABLE OF CONTENTS

	Page
ACKNOWLEDGEMENTS.....	i
PREFACE .....	ii
ABSTRACT .....	iii
EXECUTIVE SUMMARY .....	1
Introduction.....	1
Project Purpose.....	1
Project Process .....	2
Project Results.....	2
Zero-Standby Technologies.....	2
Direct Current Power .....	3
Safety, Security, and Health Devices.....	4
Test Methods .....	5
Recommended Future Work.....	6
Benefits to California .....	7
CHAPTER 1: Background and Introduction.....	9
1. Background: What Are Plug Loads and Why Are They Important? .....	9
2. Project Objective: A Multi-Pronged Strategy to Reduce Energy Used by Plug Loads .....	11
3. Organization of Report.....	11
CHAPTER 2: Zero Standby Technology Power Supplies and Devices .....	12
1. Introduction.....	12
Background and Motivation.....	12
General Approach.....	12
Portfolio of Standby Solutions.....	14
Organization .....	14
2. Burst Mode .....	15
Description.....	15
Experiment and Results .....	17
3. Sleep Transistors.....	19
General Background .....	19
Footer Switch.....	20
Header Switch.....	21

Cascoded Header Switch.....	22
4. Optical Wake Up .....	22
Infrared Wake-Up Signal.....	22
Laser Wake-Up Signal.....	24
5. Wake-Up Radio .....	26
6. Conclusion .....	29
CHAPTER 3: Efficient, Direct, Direct-Current Devices.....	30
1. Background and Motivation.....	30
Motivation for Direct Current Distribution in Buildings .....	30
Previous Works in Direct Current Modification .....	31
2. Direct Current Load Modifications.....	31
Existing Direct Current Voltage Standards .....	31
Devices that Benefit from Direct Current.....	33
Experimental Method.....	36
3. Wall Adapters.....	37
Modifications for Direct Current Input .....	37
Experimental Prototype and Results.....	37
Discussion.....	38
4. Bath Fan.....	39
Modifications for Direct Current Input .....	39
Experimental Prototype and Results.....	41
Discussion.....	43
Direct Current Capacitor Voltage in Brushless Direct Current Motors .....	43
5. Refrigerator .....	45
Modifications for Direct Current Input .....	45
Experimental Prototype and Results.....	45
Discussion.....	46
6. Task Light.....	48
Modifications for Direct Current Input .....	48
Experimental Prototype and Results.....	49
Discussion.....	50
7. Zone Lighting .....	51
Modifications for Direct Current Input .....	51
Experimental Prototype and Results.....	52



Discussion.....	54
8. Conclusions.....	55
CHAPTER 4: Reducing the Energy Use of Safety, Security, and Health Devices .....	57
1. Background and Introduction .....	57
Chapter Organization .....	57
2. Safety, Security, and Health Devices in Buildings.....	57
Safety, Security, and Health Devices and Energy-Efficiency Regulations.....	59
Existing Literature Pertaining to Safety, Security, and Health Devices Energy Use.....	60
Priority Safety, Security, and Health Devices .....	61
3. Investigations of Priority Safety, Security, and Health Devices.....	62
Introduction .....	62
Ground-Fault and Arc-Fault Circuit Interrupters .....	63
Smoke and Carbon Monoxide Alarms .....	65
Security and Alarms.....	66
Oxygen Concentrators .....	67
Continuous Positive Airway Pressure Ventilators .....	68
Exit Signs.....	69
Emergency Lighting .....	69
Mechanical Ventilation .....	70
Detailed Analysis of Residential Life-Safety Safety, Security, and Health Devices .....	70
Teardowns.....	79
5. Safety, Security, and Health Devices Energy Use.....	84
Stock and Statewide Energy Consumption.....	84
6. Prospects for Energy Reductions in Safety, Security, and Health Devices .....	87
Laboratory Research.....	88
Programmatic Activities.....	89
7. Conclusions.....	90
8. Future Work.....	91
Programmatic Activities.....	91
CHAPTER 5: Very-Low-Power Standby Products: Implications for Codes, Standards, and Test Methods .....	93
1. Scope .....	93
Test Methods .....	94
Health and Safety.....	96

2. Codes and Standards.....	96
Scope .....	96
Energy Codes and Standards.....	97
U.S. Department of Energy Appliance Standards .....	99
Health and Safety Codes.....	102
Other Health Considerations.....	103
3. Discussion.....	103
Zero-Standby Solutions.....	104
Direct Direct-Current Powered Devices .....	107
Life-Safety Devices .....	107
4. Conclusions.....	107
CHAPTER 6: Supplemental Research .....	110
1. Introduction.....	110
2. Further Ground-Fault Circuit Interrupter Measurements .....	110
3. Back-Up Batteries for Garage Door Openers.....	112
4. Low-Voltage Direct Current Home Networks.....	112
5. Plug Loads in Commercial Buildings .....	114
Plug Loads in a Zero-Net-Energy Commercial Building .....	114
Laboratory Measurements of Plug Load Devices Specific to Commercial Buildings.....	115
CHAPTER 7: Project Benefits .....	116
1. The Role of the Electric Program Investment Charge .....	116
2. Anticipated Energy Use.....	117
3. Energy Savings Resulting From This Research.....	117
4. Secondary Benefits From Energy Savings.....	119
5. Utility and Ratepayer Benefits .....	119
6. Cost/Benefit Ratios.....	120
CHAPTER 8: Technology/Knowledge Transfer .....	121
1. Target Audience.....	121
2. Publications and Presentations .....	122
Publications.....	122
Presentations .....	123
CHAPTER 9: Conclusions and Future Work .....	124
1. Conclusions.....	124
2. Zero-Standby Solutions.....	124

3. Direct Current Power .....	125
4. Safety, Security, and Health Devices.....	126
5. Test Methods .....	127
6. Recommended Future Work.....	127
Zero-Standby Solutions.....	128
Direct Current Devices .....	128
Safety, Security, and Health Devices.....	129
Codes and Standards.....	130
LIST OF ACRONYMS AND GLOSSARY .....	131
REFERENCES .....	134
APPENDIX A: Direct Current Capacitor Voltage in Brushless Direct Current Motors .....	A-1
APPENDIX B: Supplementary Material for Chapter 4.....	B-1

## **LIST OF FIGURES**

	Page
Figure ES-1: Hourly Electricity Use Profiles for Plug Loads and Total Electricity in California Office Building .....	1
Figure ES-2: A Portfolio of Standby Reduction Techniques and Solutions (Labeled Solutions Discussed in Report) .....	2
Figure ES-3: Growth in Residential Life-Safety Devices Required by Building Codes.....	5
Figure 1: Fraction of Annual Energy Use Occurring as Constant Load .....	10
Figure 2: Shrinking the Staircase.....	13
Figure 3: Generalized Power Supply .....	14
Figure 4: Standby Reduction Portfolio.....	15
Figure 5: External Burst Mode Controller .....	16
Figure 6: Simple Burst-Mode Logic .....	16
Figure 7: Burst-Mode Waveforms.....	17
Figure 8: Footer Switch .....	20
Figure 9: Operation of a Footer Switch .....	21
Figure 10: The Header Switch.....	21

Figure 11: The Cascoded Header Switch.....	22
Figure 12: Proposed IR Energy Harvesting Method.....	23
Figure 13: The Receiver for an IR-based Zero-Standby Supply.....	23
Figure 14: Prototype of the IR-Based Zero-Standby Supply.....	24
Figure 15: Four-Stage Dickson Charge Pump .....	25
Figure 16: Prototypes of the Laser-Based Zero Standby Supply.....	26
Figure 17: Wake-Up Radio System .....	27
Figure 18: Wake-Up Radio Operational Block Diagram.....	28
Figure 19: Wake-Up Radio Prototype.....	28
Figure 20: Categorization of Loads by Benefit from Direct Current Input.....	34
Figure 21: Block Diagram of a Variable Frequency Drive Motor .....	35
Figure 22: Direct-Direct Current Wall Adapter Modification .....	37
Figure 23: Direct-Direct Current Wall Adapter Discussion.....	39
Figure 24: Direct-Direct Current Bath Fan Modification .....	40
Figure 25: Direct-Direct Current Fan Prototype .....	41
Figure 26: Fan Boards .....	42
Figure 27: Efficiency Curves for the Bath Fan Boards.....	42
Figure 28: Motor Winding Area .....	44
Figure 29: Direct-Direct Current Refrigerator Modification.....	45
Figure 30: Direct-DC Refrigerator Prototype.....	46
Figure 31: LG Refrigerator Inverter Board.....	47
Figure 32: Danfoss/Secop Inverter Board .....	48
Figure 33: Direct Direct-Current Task Lamp Modification .....	49
Figure 34: Direct Direct-Current Task Lamp Prototype.....	50
Figure 35: Direct Direct-Current Task Lamp Discussion.....	51
Figure 36: Direct Direct-Current Zone Light Modification.....	52
Figure 37: Direct Direct-Current Zone Light Prototype .....	53
Figure 38: Direct Direct-Current Zone Light Prototype Efficiency .....	53
Figure 39: Original Alternative Current Light-Emitting Diode Driver .....	54
Figure 40: Fixture Bypass Circuit.....	55
Figure 41: Safety, Security, and Health Devices by Administrative Category.....	59

Figure 42: Ground-Fault and Arc-Fault Circuit Interrupters.....	64
Figure 43: Smoke and Carbon Monoxide Alarm .....	65
Figure 44: A Home Security System .....	66
Figure 45: A Stationary Oxygen Concentrator .....	67
Figure 46: Continuous Positive Airway Pressure Ventilator .....	68
Figure 47: Exit Sign.....	69
Figure 48: Emergency Lighting .....	69
Figure 49: Test Fixtures.....	73
Figure 50: Power Measurement Test Configuration .....	74
Figure 51: Example Current and Voltage Waveforms from a Smoke Alarm.....	75
Figure 52: Comparison of Ground Fault Circuit Interrupter Outlet Power.....	76
Figure 53: Plot of Power Factor with Respect to Power for All Tested Safety, Security, and Health Devices.....	77
Figure 54: Selected Safety, Security, and Health Devices Voltage and Current Waveforms.....	78
Figure 55: Measured Power Consumption of Safety, Security, and Health Devices.....	79
Figure 56: Relationship of Safety, Security, and Health Devices Power Use to Cost .....	79
Figure 57: GFO38 GFCI Outlet Teardown.....	80
Figure 58: AGO31 AFCI/GFCI Outlet Teardown—Electrical Circuit.....	81
Figure 59: GFO17 GFCI Outlet Teardown—Electrical Circuit .....	82
Figure 60: Teardown of the SMA36 Smoke Alarm—Electric Circuit.....	83
Figure 61: Teardown of the SMA07 Smoke Alarm.....	83
Figure 62: SMA07 Smoke Alarm Power Board Efficiency Curves .....	84
Figure 63: Growth in Residential Life-Safety Devices Required by Building Codes .....	87
Figure 64: The Relationship Between Codes and Standards, Test Methods, and Products .....	93
Figure 65: Rendering of Possible Components of a Standzero Device, Including Energy Harvesting Means, Energy Storage, and Logic to Control Electricity Flow Between Mains, Storage, and Harvested Energy.....	105
Figure 66: Japanese Ground-Fault Circuit Interrupter Plug Adapters.....	110
Figure 67: GFP52, a Plug Adapter (left), GFP50, a Replacement Plug (center), and GFP51 (right).....	111
Figure 68: Block Diagram for a Residential Low-Voltage Direct Current Network .....	113
Figure 69: Bench Assembly of a Low-Voltage Residential Direct Current Network with Two Loads	114

Figure 70: Standby Reduction Prototypes .....	116
Figure 71: Direct Direct Current Prototypes .....	117
Figure A-1: Winding Area Diagram for Two Motors with Equal Input Power and Magnetic Flux .....	A-1

## **LIST OF TABLES**

	Page
Table 1: PG02S2405A Normal Operation .....	18
Table 2: PG02S2405A Burst Mode.....	19
Table 3: OKX-T/5-D12N-C Normal Operation .....	19
Table 4: OKX-T/5-D12N-C Burst Mode.....	19
Table 5: Wall Adapter Efficiency.....	38
Table 6: Fan Prototype Power Consumption .....	43
Table 7: Prominent Safety, Security, and Health Devices .....	58
Table 8: Reported Power Consumption of Some Safety, Security, and Health Devices .....	61
Table 9: Priority Devices Selected for Further Investigation in This Report.....	62
Table 10: Residential Health and Safety Devices Required by Building Standards .....	63
Table 11: Power Use of Stationary Oxygen Concentrators .....	68
Table 12: Market Survey of Residential Life-Safety Devices.....	71
Table 13: Smoke Alarm Test Matrix.....	72
Table 14: Summary of Residential Life-Safety SSHDs Tested .....	72
Table 15: Summary of Test Results.....	76
Table 16: Safety, Security, and Health Devices Selected for Teardown .....	80
Table 17: Stock and Energy Consumption of Safety, Security, and Health Devices in California Buildings .....	85
Table 18: Examples of Standby Energy Use in Other Test Methods .....	95
Table 19: Low-Power-Mode Testing and Standards in California Appliance Energy Standards.....	97
Table 20: Low-Power Mode Testing and Standards in Federal Appliance Energy Standards.....	100
Table 21: Low-Power-Mode Testing and Standards in ENERGY STAR Product Specifications.....	101

Table 22: Residential Health and Safety Devices Required by Building Standards .....	102
Table 23: IEC 62301 Test Method Changes Required to Account for Zero-Standby Solutions 104	
Table 24: Ground-Fault Circuit Interrupter Plug Measurements .....	111
Table 25: Standby Power of Five Garage Door Openers with Batteries (Preliminary) .....	112
Table 26: Measurements of Commercial SSHDs .....	115
Table 27: Project Impacts: Electricity and Cost Savings, Demand and Greenhouse Gas Reduction in California .....	118
Table 28: Anticipated Benefits and Costs .....	120
Table 29: Target Audiences .....	121
Table B-1: Life-Safety Devices Purchased for Detailed Analysis .....	B-1
Table B-2: Selected SSHD Test Results.....	B-4





# EXECUTIVE SUMMARY

## Introduction

Plug loads are generally defined as devices connected to an alternating current power outlet using a cord and plug. Modern buildings contain hundreds of plug loads ranging from all sorts of electronic devices to coffeemakers to under-sink water heaters and aquariums. Large residential and commercial devices including furnaces, clothes washers, and dryers are not included in this study. The term “plug load” itself is unusual since it defines products by how they are powered instead of how they function.

Regardless of the definition, plug loads consume a considerable amount of electricity, or energy; they are responsible for at least 25 percent of energy use in California buildings. Figure ES-1 shows profiles for both the hourly electricity draw of plug loads and their total electricity consumption in a California office building.

**Figure ES-1: Hourly Electricity Use Profiles for Plug Loads and Total Electricity in California Office Building**

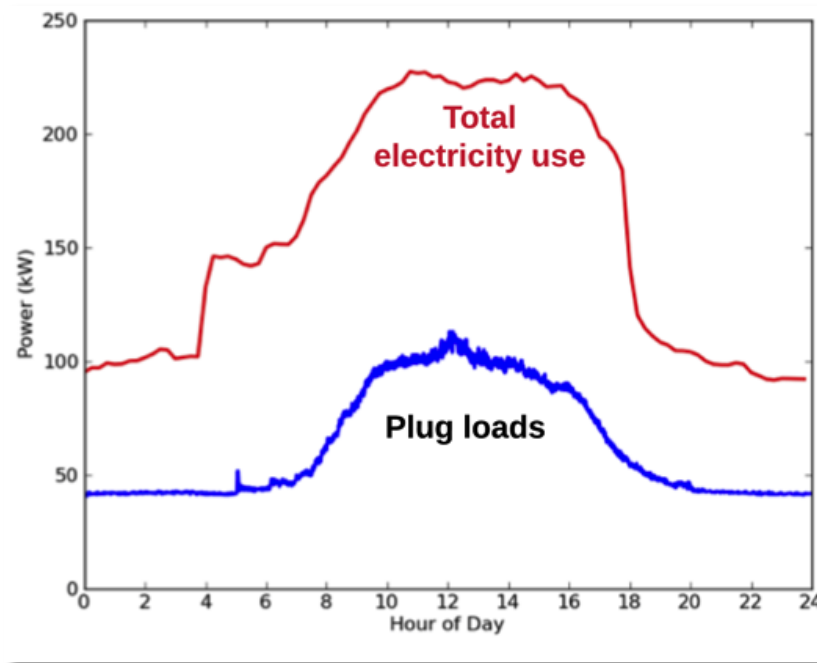

Source: LBNL

In California, electricity demand for plug loads is about 50,000 gigawatt-hours (GWh) per year, although estimates differ because definitions of plug loads themselves differ. Unlike other end uses of electricity, the energy consumed by plug loads appears to be increasing. The “Internet of Things,” loosely defined as a system of interrelated computed devices that automatically transfer data over a network, is, to a great extent, the “Internet of Plug Loads,” in both residential and commercial buildings.

## Project Purpose

The goal of this project goal was to advance technologies that will reduce plug-load energy use in existing and zero-net-energy (ZNE) buildings, including making the electricity consumed

by plug loads easier to supply from ZNE building onsite renewable energy resources. Less energy use by this category will reduce electricity use, carbon emissions, and consumer costs.

### Project Process

The methods adopted in this project included paper studies, field measurements, laboratory tests, and technical innovation. Research was undertaken in all areas; the diversity of plug loads meant, however, that for some devices only the first step could be accomplished. In others, however, commercialization is already underway. Limited resources prevented an in-depth, comprehensive project approach, so the project team focused on devices where researchers believed substantial innovations could be possible. Effectively guiding new technologies into the commercial world is as important as developing them in the first place, so this report also considers the existing codes, standards, and other policies and restrictions that affect plug-load energy use.

### Project Results

The project was divided into major tasks. The results for each task are summarized here.

### Zero-Standby Technologies

Standby power consumption is the electricity consumed by a device when either switched off or not performing its principal function. Standby power consumes about 3 to 16 percent of residential electricity use. Earlier reductions in standby-energy usage by single devices were achieved through government regulations; voluntary initiatives have been offset by growth in the number of devices consuming standby-power use. This research sought methods to reduce standby-power use to zero or nearly zero. For reference, saving 1 watt of continuous power corresponds to 8.8 kilowatt-hours (kWh) per year, or about \$1.50 per device at typical California residential electricity rates.

The past works discussed in this report have proposed numerous standby solutions for many plug-load devices, but burst mode, sleep transistors, optical wake-up, and wake-up radios appear to be most promising. As shown in Figure ES-2, these solutions contribute to the growing portfolio of standby-reduction technologies.

**Figure ES-2: A Portfolio of Standby Reduction Techniques and Solutions (Labeled Solutions Discussed in Report)**

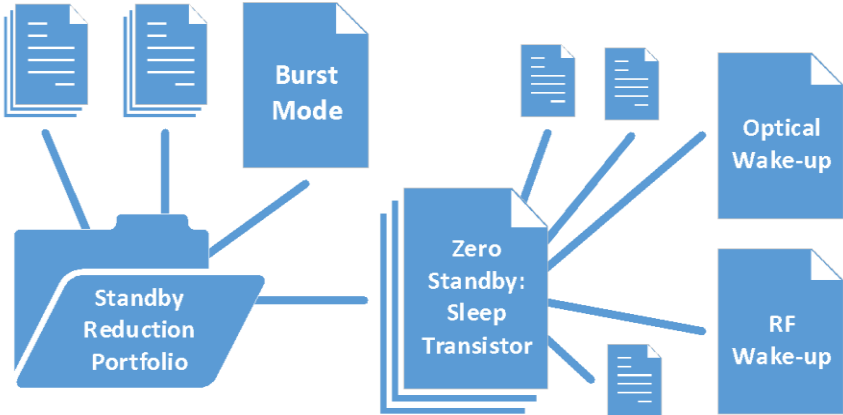

Source: LBNL

Figure ES-2 also summarizes this project's key components as they relate to reducing standby-power usage.

Each solution in this particular report uses a sleep transistor, which is a solid-state standby-killer switch that can either connect or disconnect the main device from its power supply. The first solution demonstrates the value of "burst mode" for lightly loaded power converters. Burst mode allows a lightly loaded power converter to operate at a higher-efficiency point. A stand-alone controller was developed that could enhance any power converter with burst mode.

The second and third solutions use optical energy harvesting to turn on line-of-sight remote-controlled devices like televisions, set-top boxes, lights, and fans. One uses infrared light (IR) energy harvesting to wake the device. However, the prototype could not deliver sufficient activation energy because the IR beam was too diffuse. In the other solution, the receiver instead harvested visible light energy from a laser pointer, so it could activate a device at a range of 25 meters. However, its drawback is in the spatial accuracy required to hit a small target with the laser pointer.

The fourth solution uses an ultra-low-power "wake-up radio" to activate the device. The prototype's range is limited to 3 meters due to its low-frequency magnetically-coupled wireless communication, but it nonetheless demonstrated the principle of using a wake-up radio in conjunction with burst mode and a sleep transistor.

This work demonstrates zero or near-zero standby power to be technically feasible in several families of products. These solutions have both advantages and drawbacks and will require further technical improvements and cost reductions before they can be commercialized and introduced into new devices. In addition, the portfolio of solutions will need to be broadened before standby-power use can be confidently — and economically — eliminated. There is reason to be optimistic, however, since many of the technologies investigated in this project barely existed just a decade ago.

## **Direct Current Power**

This work categorized the types of loads where efficiency directly benefited from a direct current input. Direct current-connected loads can connect directly to higher-efficiency direct current distribution at lower cost. Direct current input also allows for a great reduction in the size of capacitors and improves power quality. Several types of loads were modified or prototyped as direct-current, including an external power supply, bath fan, refrigerator, and task lamp. The purpose of each design was to leverage direct current input to improve the efficiency of the conversion.

In electronics, direct current input allows for the downsizing or elimination of wall adapters. The efficiency benefits generally favor direct current, though comparisons must be made with careful attention to the distribution voltage and conversion process. In motor loads, the most efficient type of brushless direct current motor is designed so that its internal direct current capacitor bus naturally operates at the direct current input voltage. Although there is very little loss across a diode-bridge rectifier, a power-factor-correction boost rectifier is notably less efficient. In lighting, task lamps that connect to a universal serial bus power adapter with programmable power supply capability can use the adapter as the light-emitting diode driver.

Zone lighting can benefit greatly from remote drivers, but further research must validate its feasibility.

Direct current power distribution networks are becoming increasingly attractive because they provide energy savings and security during power outages, especially when attached to a battery and a dedicated photovoltaic panel. The project team constructed a prototype and conducted tests to demonstrate this concept.

## **Safety, Security, and Health Devices**

This investigation identified a unique category of energy-using devices that provide safety, health, and security to buildings. Installation or use of safety, security, and health devices is dictated by building codes, health providers, insurance companies, and other entities. None of these entities would ordinarily consider energy efficiency as a priority feature. While safety, security, and health devices are currently responsible for about 2 percent of total residential electricity use, they are a rapidly growing category and represent about 10 percent of electricity use in a new home.

Many safety, security, and health devices are “builder-installed loads,” or loads installed by builders in new homes to comply with codes or meet customer expectations. Examples include ground-fault circuit interrupters (GFCIs), arc-fault circuit interrupters (AFCIs), hard-wired smoke alarms, continuous mechanical ventilation, and illuminated street numbers. Figure ES-3 shows the rise in code-required safety devices in homes.

Measurements of 13 new homes showed that builder-installed loads were responsible for an average 1,200 kWh per year, or 17 percent of an average California household’s electricity use, before occupants had even moved in. In-home medical equipment such as oxygen concentrators, which consume about 3,000 kWh per year per unit, have become a major energy consumer in homes where they are used. While safety, security, and health device energy use as a whole can be significant, most individual devices consume little electricity and therefore offer small energy savings, even when reductions of 80 percent are technically feasible. Efficiency improvements may still pay for themselves in reduced operating costs, but even though the improvements will pay for themselves consumers, contractors, and others will not spend either time or money implementing changes when the payoff is so small.

Diverse strategies are needed to reduce future safety, security, and health device energy consumption. For GFCIs and mechanical ventilation systems, the best-on-market models consume less than half as much power as typical models. Efficiencies of medical equipment could be greatly improved through better compressors and controls. Battery-charging systems for a host of devices can also be more efficient.

A strong case exists for the improved efficiency of GFCIs since their greater efficiency does not appear to increase costs. The average power use of a sample of U.S. GFCIs was 1.67 watts, while models available in Japan drew less than 0.20 watts; one model drew only 0.09 watts (or 5 percent of the average U.S. model). This project was unable to determine if the lower electricity use was caused by superior components or different performance requirements. Further research is needed.

**Figure ES-3: Growth in Residential Life-Safety Devices Required by Building Codes**

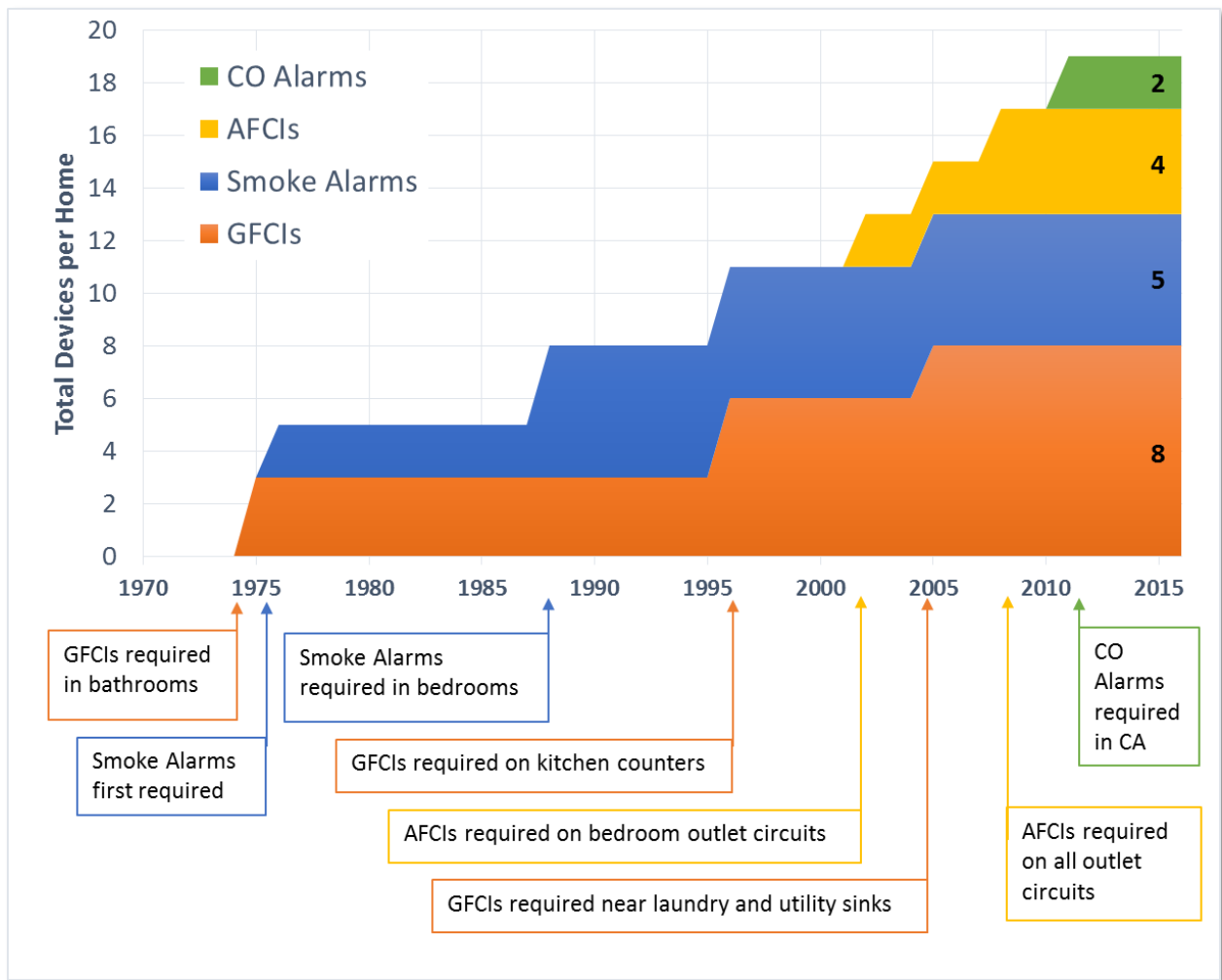

Current number of individual devices is shown on the right.

Source: LBNL

Wildfires in California caused power outages and several deaths when people were unable to open their garage doors when the power went out. For this reason, California recently enacted legislation requiring that new garage doors be equipped with backup batteries. The battery chargers continuously add a few watts to a home’s electricity usage, and batteries must be periodically replaced. This safety, security, and health device’s energy use could be mostly offset if it is incorporated into a direct current network, described earlier.

### Test Methods

Test methods, codes, and standards do not yet capture the unique features of plug loads with zero-or-very-low standby power. Those unique features span energy consumption, behavior, materials, and health and safety. Establishing test methods and standards is especially challenging since most products have a small environmental footprint (drawing less than a few watts of power and consisting of only a few grams of materials); but the cumulative impact of billions of these small plug loads is enormous.

For nearly all energy test methods, the boundaries of measurement need to be re-considered to reflect new behaviors of technologies. The boundaries include upstream-energy use, the environment, and the measurement's duration. In new, very-low-energy commercial buildings, traditional hot water end use is disappearing and being replaced by small, under-sink water heaters, which create new plug loads. Simulations for code compliance need revision to capture this trend.

All test methods and standards must consider the reality that more and more products will operate for longer periods unconnected to the grid. This inevitable phenomenon extends beyond today's portable electronics to electric vehicles and vacuum cleaners. The testing dilemma is how to define (and measure) standby modes when "disconnected" may become a common configuration.

Higher-power direct current products are appearing in the market, but energy-test procedures have not yet been updated to reflect this market shift. The ultimate goal should be comparable treatment for both AC and direct current products.

Future zero-standby solutions may require that manufacturers comply with new health and safety requirements. For example, lasers could be used to harvest energy. Life-cycle assessments of materials connected with low-standby technologies need further investigation. Most studies of energy storage, for example, focus on much larger products.

Fortunately, none of these requirements appear insurmountable.

Health and life-safety devices are currently exempt from most energy standards and codes. Project research suggests that energy consumption for these products is growing as home healthcare increases and evolves.

## **Recommended Future Work**

This project covered several distinct research areas, so recommended future work is naturally and necessarily diverse. No single technology will eliminate standby-power use, but several technologies appear promising for specific applications including the wake-up radio, burst mode, and energy harvesting and storage combinations. In the long run, coordinating improvements in efficiency, energy harvesting, and energy storage will be the best strategy for achieving zero-standby-power use. Rather than focusing on the products themselves, direct current power research should instead focus on the robust integration of products such as improving direct current network power management and developing direct current networks of high-priority communications and safety devices, possibly supported by storage and dedicated photovoltaics.

For devices providing safety, security, and health, future work should focus on moving the market to high-efficiency products that are already available. In some cases, such as for GFCIs, this alone could achieve almost 80 percent energy savings. For smoke and carbon monoxide alarms, research should be undertaken to eliminate the need altogether for a power supply. This might be accomplished through a 10-year battery, possibly combined with energy harvesting. This solution will require altering building codes, but it could reduce overall costs if wiring costs are eliminated. Some safety devices, notably garage door openers, may benefit from connection to a new direct current network. These networks offer other important

benefits such as resiliency to power outages and reduced environmental burdens caused by battery replacements.

A sustained research effort will be required to improve the sensitive issue of the energy efficiency of devices where health or safety considerations hobble or slow innovation. This research needs to be carefully linked with health and safety communities to fully and accurately understand human health needs, identify technical solutions, and field-test prototypes. The first two targets should be oxygen concentrators and mechanical ventilation systems.

## **Benefits to California**

When the technologies researched in this project are ultimately adopted, California will reduce its electricity use by an estimated 6,000 GWh per year and save ratepayers about \$1.2 billion per year. Electric demand will also be reduced by 690 megawatts, and greenhouse gas emissions will be reduced by an equivalent 1,900 million tons of carbon dioxide each year.

This report concludes with future research and actions that could lead to even further energy savings, increased energy security and safety.





# CHAPTER 1:

## Background and Introduction

---

### 1. Background: What Are Plug Loads and Why Are They Important?

Plug loads are generally defined as the devices plugged into 120-volt alternating current (AC) power outlets. These products are mostly electronics and miscellaneous devices. There are hundreds of plug loads in modern buildings. Some examples of plug loads in homes are TVs, printers, cordless phones, coffeemakers, vacuum cleaners, and aquariums. In commercial buildings, some plug loads are computers, copiers, Ethernet switches, and under-sink water heaters. The term “plug load” is unusual because it defines products by the way they are powered instead of by the device’s function. Researchers and policymakers typically use other names for this group of electricity-using products. The most common term is “miscellaneous electrical loads” or its acronym “MELs,” but is also referred to as simply “other uses.” Statisticians have sometimes even called it “residual” energy use, reflecting consumption remaining after accounting for space heating, cooling, water heating, and other recognized end uses.

Regardless of the name assigned to them, plug loads are a significant category of energy consumption. They are responsible for at least 25 percent of energy use in U.S. buildings (U.S. Department of Energy 2015) and an even larger percentage in California buildings. In California, electricity demand attributed to plug loads is about 50,000 GWh per year (EPIC 2015), although estimates differ because definitions of plug loads themselves vary. Unlike other end uses of electricity, the energy consumed by plug loads appears to be increasing. The enormous contribution of plug loads to California’s building energy use was highlighted in two recent studies. In a detailed analysis of an existing office building (Lanzisera et al. 2013), plug loads were responsible for 40 percent of the building’s electricity use (Figure ES-1).

A second study (Borgeson 2013) of hourly electricity consumption of 25,000 Northern California homes showed that continuous electricity use—caused mostly by plug loads—was responsible for more than 40 percent of the total electricity used in about half of the homes (Figure 1).

Plug loads are also changing in response to demographic and environmental trends. Two examples explored in this report highlight these linkages. The aging population (along with health-care policies) has pushed numerous medical services—and equipment—into homes. As a result, home oxygen concentrators have become large plug loads. The tragic wildfires in California caused power outages and, in a few cases, caused deaths because people in affected areas were unable to open their garage doors. As a result, recent California legislation now requires that new garage doors be equipped with batteries to supply back-up power. These back-up systems have therefore become a new plug load.

**Figure 1: Fraction of Annual Energy Use Occurring as Constant Load**

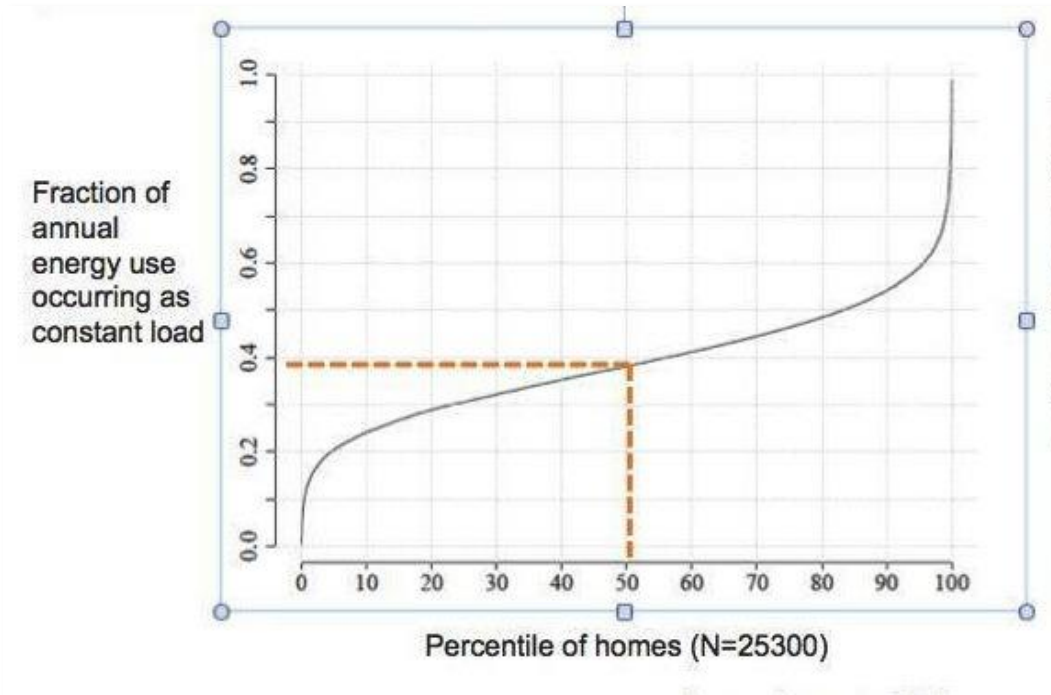

Source: Borgeson 2013

A characteristic of plug loads is their continuous draw of electricity, even when not providing their principal services or functions. This is called “standby power use.” Many electronic devices have standby power use, if only because they have power supplies that convert AC into direct current (DC). Standby power use in most modern electronic devices is generally small—less than 2 watts (W)—but is nevertheless significant because this consumption continues 8,760 hours per year and because there are so many old, high-standby electronic devices in buildings today. For that reason, reducing standby power continues to be a goal of energy efficiency strategies.

Meanwhile, California has mandated ambitious reductions in energy use and climate-related emissions, including requirements for future buildings to consume almost zero net energy (California Air Resources Board 2014). Meeting these climate and energy targets will require large reductions in all end uses of energy, but especially in plug loads. California cannot achieve these twin goals without a dramatic reduction in plug load energy use.

A host of diverse factors will influence the extent and speed at which the market adopts energy-saving plug loads. The financial payback for reducing plug loads is challenging because of the small dollar savings resulting from an individual device’s saved energy. Saving 1 watt continuously over one year totals less than 10 kilowatt-hours (kWh), or about \$1.50. Many consumers will reject these opportunities because they are either unaware of them or think that they are not worth the effort. Manufacturers will be reluctant to make improvements because of the uncertainty that consumers will pay a premium for higher efficiency. However, when a household has more than 100 plug loads (and a commercial building has thousands), the collective savings become important to both the occupants and to society at large. Therefore, an important goal is to find compelling reasons for consumers to choose devices that offer new features that just happen to include greatly reduced energy consumption.

## **2. Project Objective: A Multi-Pronged Strategy to Reduce Energy Used by Plug Loads**

The aim of this project was to develop technologies that will reduce the energy use of new plug loads. Lower energy use by this category will reduce electricity use, carbon emissions, and consumer costs. When these products achieve very-low-energy use, consumers will also be able to more economically tap renewable energy sources. No single technology will reduce energy use in new plug loads because they are so diverse. Some technical solutions can nonetheless apply to families of products. One theme of this research project was “powering” plug loads differently to reduce energy use. Powering differently means shifting away from total reliance on electricity from the 120 Volt (V) outlets through combinations of DC power, energy harvesting, enhanced device control and, of course, increased efficiency. However, many plug loads have unique requirements—such as medical and life-safety devices—and must therefore be examined individually.

This project’s approach was multi-pronged and consisted of three steps to:

- Identify plug loads and evaluate current technologies.
- Develop low-energy technologies.
- Commercialize solutions.

Limited resources prevented a comprehensive approach; instead, the project focused on aspects where the research team believed that significant innovations were possible. In addition, this report considers the codes, standards, and other policies that affect plug load energy use.

## **3. Organization of Report**

This report describes research and findings on technologies that reduce the electricity consumption of plug loads. Chapter 2 focuses on methods to reduce standby power use in new devices. Solutions to this problem will apply to hundreds of different products in residential and commercial buildings. Chapter 3 explores methods of powering plug loads with DC (rather than AC) and applies those methods to actual devices. Chapter 4 addresses plug loads that provide safety, health, and security services in buildings. Here, too, the products are diverse, but they share many performance and institutional characteristics. Chapter 5 reviews codes and standards applicable to plug loads. Several smaller investigations and updates are summarized in Chapter 6. The project’s overall benefits are described in Chapter 7, and the ways in which the findings have been transferred to Californians are covered in Chapter 8. Finally, Chapter 9 offers some conclusions and recommendations for future research and activities related to plug load electricity use.

# CHAPTER 2: Zero Standby Technology Power Supplies and Devices

---

## 1. Introduction

### Background and Motivation

Standby power consumption by appliances, electrical devices, and other products is a global problem: continues to represent 3 to 16 percent of residential electricity use, although that percentage varies by country (IEA 2001; Urban, Tiefenbeck, and Roth 2011; Delforge, Schmidt, and Schmidt 2015; T. K. Lu, Yeh, and Chang 2011; De Almeida et al. 2011; Clement, Pardon, and Driesen 2007). Considerable progress in reducing standby consumption in specific products has been achieved through a variety of policies and technologies. For example, technical advances in mobile phone chargers, the “poster child” of standby consumption, have enabled reductions in standby power from more than 2 watts in 2000 to below 0.3 watt today. Most new low-voltage power supplies have standby power consumptions below 0.5 watt, reflecting minimum energy efficiency standards in Europe, California, and elsewhere (IEA 2014).

However, the last 20 years have seen an explosion in the number of devices that rely on power supplies and continuous power consumption. This growth can be attributed to the proliferation of devices that operate entirely on DC power, traditional AC-powered devices that now have electronics, and mobile devices with batteries. Many of these devices fall into the MELs category, which continues to grow rapidly in terms of both population and energy use (Comstock and Jarzomski 2012). At the same time, many more devices require higher functionality in order to sustain communications.

With the increasing number and diversity of electronic products with standby modes, the need to reduce standby power therefore continues to be an important policy and technical challenge. However, as technologies mature, there is a declining potential savings per device, coupled with an increasing number and diversity of electronic products with standby modes. This means that the costs of “saving the last watt” must be extraordinarily low to be cost-justified. For reference, saving 1 watt of continuous power corresponds to only 8.8 kWh/year, or about \$1.50 at typical California residential electricity rates.

This work describes several approaches to further reductions in standby power consumption of new plug loads, some of which completely eliminate standby. The tremendous diversity of products with standby consumption means that no single solution is likely to emerge. Instead, a portfolio of widely applicable solutions presents the best path forward, and this work contributes to that portfolio.

### General Approach

The energy consumption behavior of a device can be represented as a histogram of the time it spends in each power mode. As shown in Figure 2, most modern devices have continuous

low-power standby consumption, with brief intermittent periods of high-power operation. They may utilize other intermediate power modes that, if relatively low, may be lumped into the standby category. The area under the curve corresponds to the device's annual energy consumption. The solutions described in this report target the long periods of very-low-power use and, ultimately, the other low-power modes. The goal is to reduce the power and duration of those modes in a savings strategy referred to as "shrinking the staircase," which is also illustrated in Figure 2.

**Figure 2: Shrinking the Staircase**

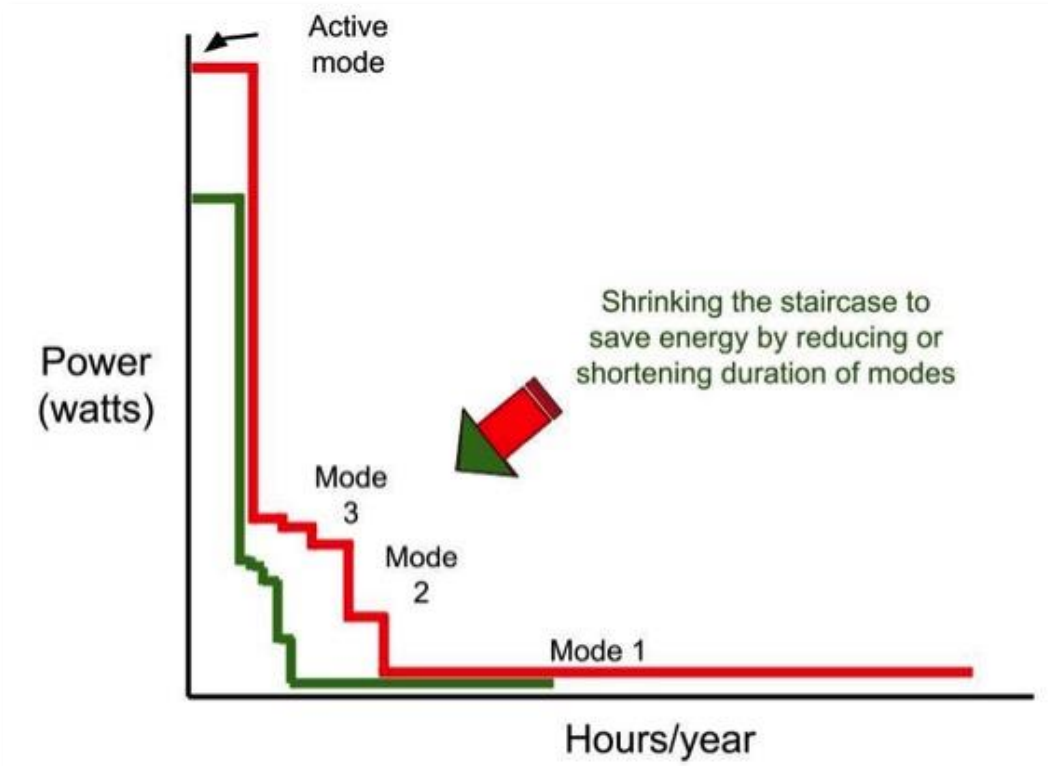

An example of the distribution of an electrical device's power modes with respect to time. The red "staircase" represents the initial modes, and the green staircase represents the impact of numerous energy-saving modifications.

Source: Alan Meier

There are several technical strategies for shrinking the staircase and reducing standby energy consumption. First is increasing the device's efficiency at various modes, which lowers overall power consumption. Another technique involves augmenting the device to harvest and store ambient energy, which can then be used during low-power operation. Finally, modifications in operational design and internal circuitry can remove consumption at various low-power modes altogether, depending on the application. This paper focuses on the latter technique and describes several methods for removing standby consumption.

The strategies applied to a power supply are generalized and illustrated in Figure 3. In certain applications of these strategies, the device can operate for periods of time without any grid-supplied power (Ellis, Siderius, and Lane 2015). The no-grid power time has been termed the "standzero" time (Meier and Siderius 2017). Many mobile devices already have long standzero

times, and the solutions described in this paper illustrate standzero strategies in various other types of devices.

**Figure 3: Generalized Power Supply**

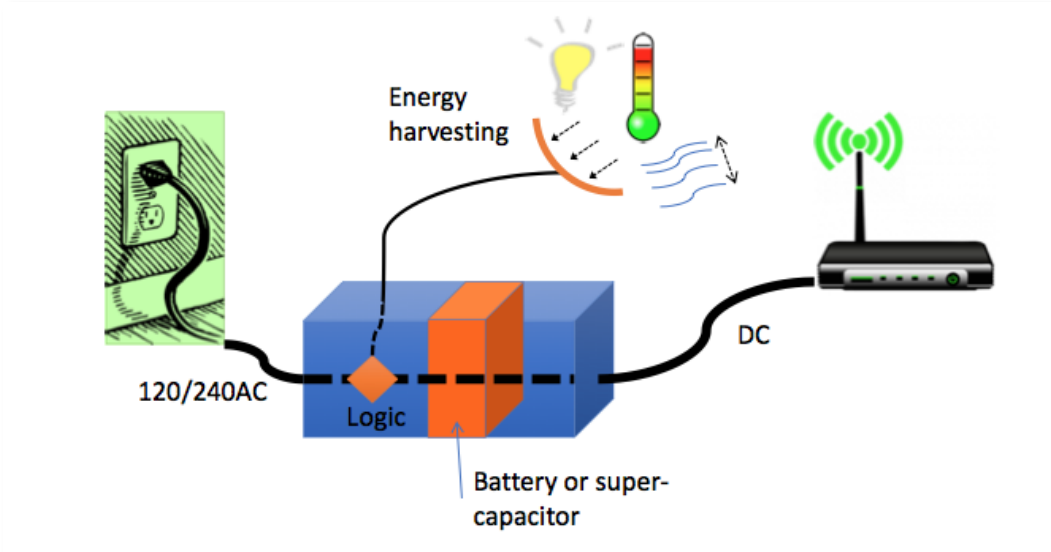

**A generalized power supply that leverages energy harvesting, storage, and/or other mechanisms to reduce standby power consumption**

Credit: Alan Meier

## Portfolio of Standby Solutions

The wide diversity of electronics featuring standby modes mandate development of a portfolio of solutions. Past works have proposed numerous standby solutions for many applications. Of these solutions, the most relevant to this paper are burst mode (Lo, Yen, and Lin 2008; Lee et al. 2013; B.-C. Kim, Park, and Moon 2011; Huh et al. 2004), sleep transistors (Jiang, Marek-Sadowska, and Nassif 2005; Shi and Howard 2006; Long and He 2004; Fallah and Pedram 2005; Fukuoka et al. 2013, 2012; Chao and Harrison 2008), optical wake-up (Kang et al. 2011; Yamawaki and Serikawa 2015a, 2015b), and wake-up radio (Demirkol, Ersoy, and Onur 2009; Magno et al. 2014; Umeda and Otaka 2007; Gamm et al. 2010; Oller et al. 2013). As shown in Figure 4, these solutions contribute to a growing standby-reduction portfolio.

## Organization

This work focuses on describing the evaluation of several different standby-reduction technologies through analysis and prototypes. Section 2 of this chapter describes burst modes for power converters and experimentally demonstrates its savings potential. Section 3 explains the operation of sleep transistors such as the footer, header, and cascoded (stacked transistor) header switch. Finally, in Sections 4 and 5 these techniques are used to prototype zero-standby solutions with optical-and radio-frequency (RF)-based wake up signals, respectively.

**Figure 4: Standby Reduction Portfolio**

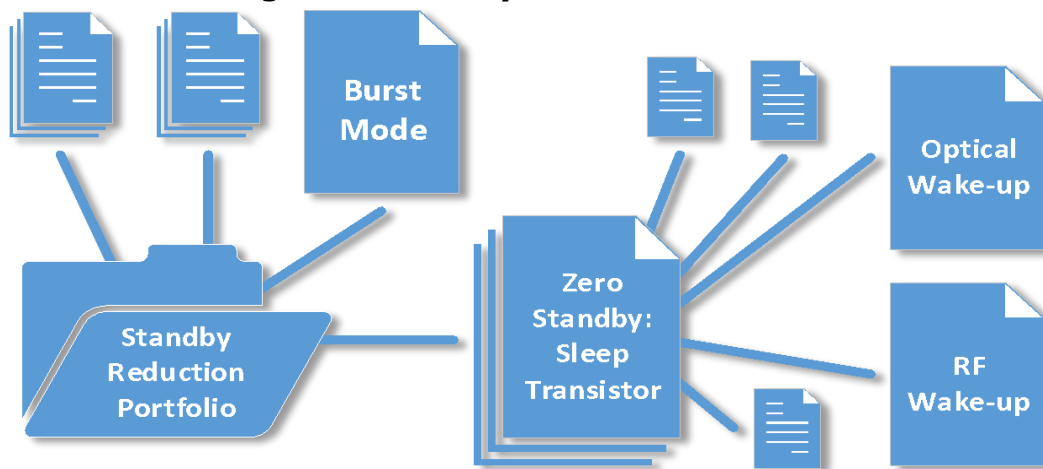

A portfolio of standby reduction techniques and solutions. The labeled solutions are discussed in this report.

Source: Daniel Gerber

## 2. Burst Mode

### Description

Burst mode is a control method for switching power converters. This method was developed in the early 2000s to address standby consumption (Lo, Yen, and Lin 2008; Lee et al. 2013; B.-C. Kim, Park, and Moon 2011; Huh, Kim, and others 2004). Lightly loaded power converters are generally inefficient because of losses in switching and control that remain constant regardless of output power. Burst mode allows a converter to temporarily shut down and power the load from its output supply capacitor. However, the converter must periodically turn on to recharge the capacitor.

As shown in Figure 5, burst mode can be implemented with a supply capacitor and special burst-mode logic. Ideally, the power converter has an enable pin that allows the burst controller to shut down the converter.

As shown in Figure 6, a simple burst controller can be implemented with two resistors, two voltage references (band gap or low-dropout), two comparators, and a set-reset (SR) latch. These components can all be easily integrated into the power converter's controller. The resistor divider scales the voltage on the supply capacitor, which is then compared with a high and low reference. If the scaled voltage falls below the low reference, the latch is set, and the converter is enabled. Once the scaled voltage rises above the high reference, the latch is reset, and the converter is disabled.

**Figure 5: External Burst Mode Controller**

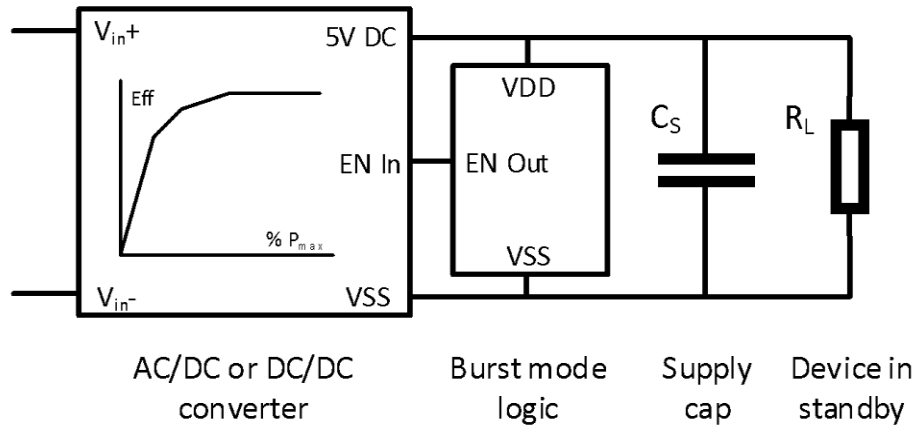

Burst mode requires a supply capacitor and its necessary recharge logic. Converters that do not already have burst mode can still be used in burst mode if they have an enable (EN In) pin.

Source: Daniel Gerber

**Figure 6: Simple Burst-Mode Logic**

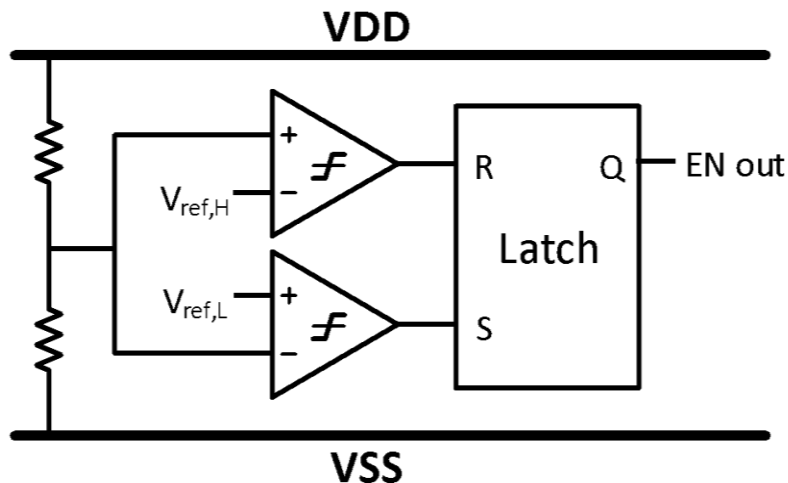

One of the simplest types of burst mode logic. The resistor divider scales the supply capacitor voltage, which is compared to high and low references. The reference voltages can be generated by nano-watt band gap references or low dropout regulators. The comparators drive an SR latch, which determines if the converter is enabled.

Source: Daniel Gerber

Converters generally perform poorly at low power, as indicated by the efficiency curve embedded in Figure 5. Instead of constantly operating at a low point on the curve, burst mode allows the converter to operate at a high point for a short period of time. Burst mode completely shuts down the converter, allowing for savings on the switching and controller losses within the converter.

Burst mode's most notable drawback is that the output voltage will ripple between the two voltage thresholds, depending on the burst logic and the size of the output capacitor. Nonetheless, many electronics can tolerate a small voltage ripple, particularly in standby mode. In some cases, the ripple introduces audio-frequency noise, which can be problematic in certain analog applications. Another minor drawback is in the resistive losses from charging



and discharging the supply capacitor, which is usually minor when compared with the potential savings.

### Experiment and Results

Burst-mode prototypes were created following the schematics in Figure 5 and Figure 6, and verified by the oscilloscope traces in Figure 7.

**Figure 7: Burst-Mode Waveforms**

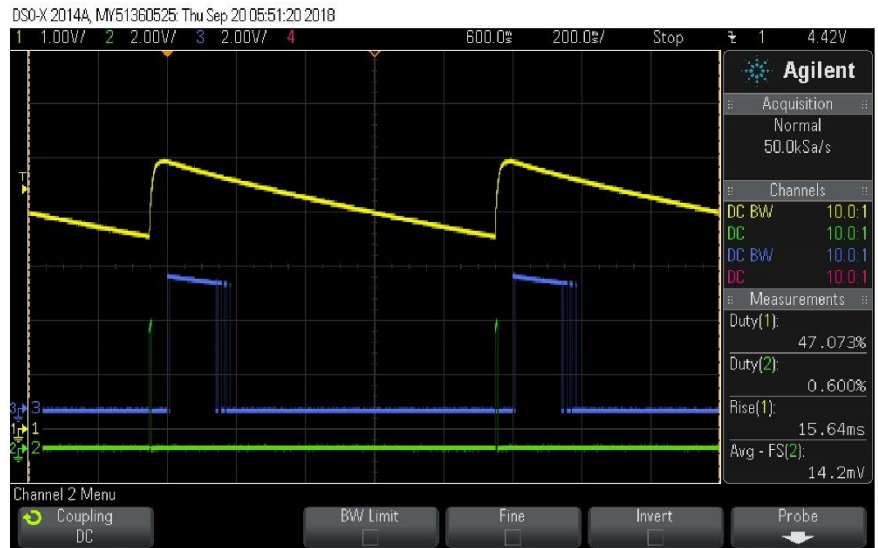

(a)

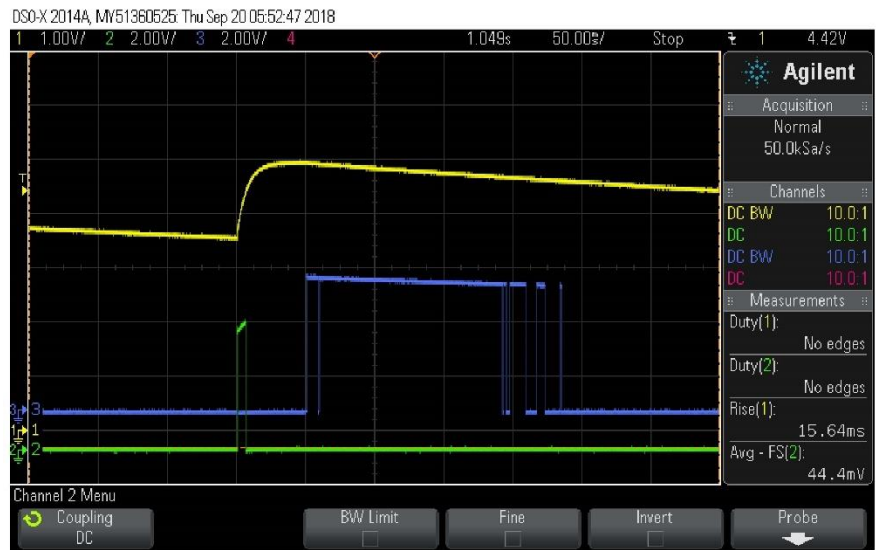

(b)

Oscilloscope waveforms with the supply capacitor voltage (yellow), low threshold comparator output (green), and high threshold comparator output (blue). These waveforms are from the PG02S2405A, loaded with a 4.7 kΩ resistor.

Source: Daniel Gerber

The burst period in these experiments ranged from 0.25 to 2.25 seconds depending on the load. Nonetheless, 0.25 seconds is considerably longer than most products with burst mode,

many of which have smaller-output supply capacitors. These prototypes experimented with adding burst mode functionality for two DC/DC converters: the 2 W Delta PG02S2405A and the 25 W Murata OKX-T/5-D12N-C. These converters do not inherently have burst mode, but they each have an enable (EN) pin and a 5-volt output. The burst mode controller is comprised of a TPS78001DDCR LDO reference, MCP6542 comparator, CD4043BE latch (output requires inversion), and two 10 millifarad (mF) 10-volt electrolytic supply capacitors. These components all have an ultra-low quiescent current of 500 nanoamperes (nA), 600 nA, and 100 nA, respectively. Finally, the LDO outputs and resistor divider were stabilized with 33 nanofarad (nF) and 3.3 nF capacitors, respectively.

The experiment compared burst mode and normal operation for each converter. It simulated standby consumption by loading the converter with 470 ohms ( $\Omega$ ), 4.7 kilo-ohms ( $k\Omega$ ), and 47  $k\Omega$  resistors ( $R_L$ ). The output power was measured in normal operation, and estimated in burst mode. The burst-mode estimate solved for the average power based on the burst period  $T$ , and the high and low voltages  $V_1$  and  $V_2$ , respectively:

$$P_{avg} = \frac{1}{R_L T} \int_0^T (V_1 e^{-t/\tau})^2 dt$$

$$\tau = \frac{T}{\ln(V_1) - \ln(V_2)} .$$

As shown by the results in Tables 1–4, burst mode can save a considerable amount of energy for light loads. The unloaded average power consumption of the PG02S2405A and OKX-T/5-D12N-C is 89 milliwatts (mW) and 471 mW, respectively. The burst mode’s savings are primarily a result of eliminating the unloaded input power. These savings become less significant with heavier loads with smaller load resistance.

This work makes several recommendations for industry’s consideration. First, more converters should be designed with a burst mode capability. In particular, application-specific wall adapters should always consider burst mode, depending on the tolerable voltage ripple for the application in standby mode. Second, packaged converters without burst mode should contain an enable pin so that burst mode can be added as the application allows. Finally, a separate burst mode logic chip should be designed for such converters.

**Table 1: PG02S2405A Normal Operation**

<b>Load Resistance (<math>\Omega</math>)</b>	<b>Average Input Power (MW)</b>	<b>Average Output Power (MW)</b>	<b>Efficiency (%)</b>
470	153.5	52.1	34.0
4,700	95.4	5.2	5.5
47,000	90.7	0.5	0.6

Source: LBNL

**Table 2: PG02S2405A Burst Mode**

Load Resistance ( $\Omega$ )	Average Input Power (MW)	Output Power Estimate (MW)	Efficiency (%)
470	80.3	36.4	45.3
4,700	14.9	3.9	26.0
47,000	8.5	0.4	4.6

Source: LBNL

**Table 3: OKX-T/5-D12N-C Normal Operation**

Load Resistance ( $\Omega$ )	Average Input Power (MW)	Average Output Power (MW)	Efficiency (%)
470	528.0	52.7	10.0
4,700	476.1	5.3	1.1
47,000	473.6	0.5	0.1

Source: LBNL

**Table 4: OKX-T/5-D12N-C Burst Mode**

Load Resistance ( $\Omega$ )	Average Input Power (MW)	Output Power Estimate (MW)	Efficiency (%)
470	177.5	36.8	20.7
4,700	44.2	3.8	8.6
47,000	29.5	0.4	1.3

Source: LBNL

### 3. Sleep Transistors

#### General Background

A sleep transistor is a type of solid-state power switch that can electrically disconnect the main device or module from its power rails. Solid-state switches are preferable over mechanical relays in low-power electronics since they do not corrode and have a considerably faster switching speed. Sleep transistors have traditionally been used for selectively deactivating modules in digital integrated circuits (ICs) (Jiang, Marek-Sadowska, and Nassif 2005; Shi and Howard 2006; Long and He 2004; Fallah and Pedram 2005). In particular, low-voltage digital ICs greatly benefit from sleep transistors due to the excessive sub-threshold leakage present in low-voltage transistors. Sleep transistors with high-gate thresholds have been applied in these modules to block that leakage current.

There are two main sleep transistor configurations: the footer switch and the header switch. It is important to note that the footer and header switches only work with a DC supply. Future work may extend these solid-state solutions to AC through the use of triacs.

Either configuration also can be cascoded (stacked transistors) to allow for greater blocking voltage. Sleep transistors can have drawbacks such as on-state resistance and leakage

current, but these drawbacks can usually be mitigated by proper metal-oxide semiconductor field-effect transistor (MOSFET) selection.

### Footer Switch

The footer switch, shown in Figure 8 and Figure 9, is an N-type MOSFET that connects the ground of the main device to the ground of the power supply. Due in part to their simplicity and reliability, footer switches have become a recent favorite in standby-reduction techniques (Fukuoka et al. 2013, 2012).

The footer switch allows the main device to completely shut down, resulting in zero standby-power consumption. However, the device can only turn on if a sufficient wake-up drive signal is applied at the gate of the footer switch. Once awake, the device must also latch the gate high to maintain its connection to the supply ground. After completing its operation, the device can return to a zero-standby mode by unlatching the footer switch gate. Sections 4 and 5 detail various methods for providing this wake-up signal.

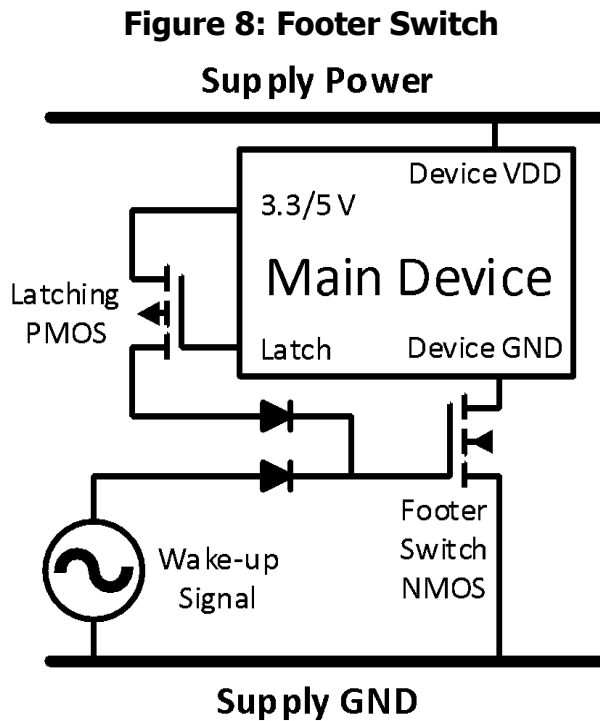

**A footer switch connects the device ground to the supply ground. A wake-up signal is required to drive the gate of the footer switch.**

Source: Daniel Gerber

**Figure 9: Operation of a Footer Switch**

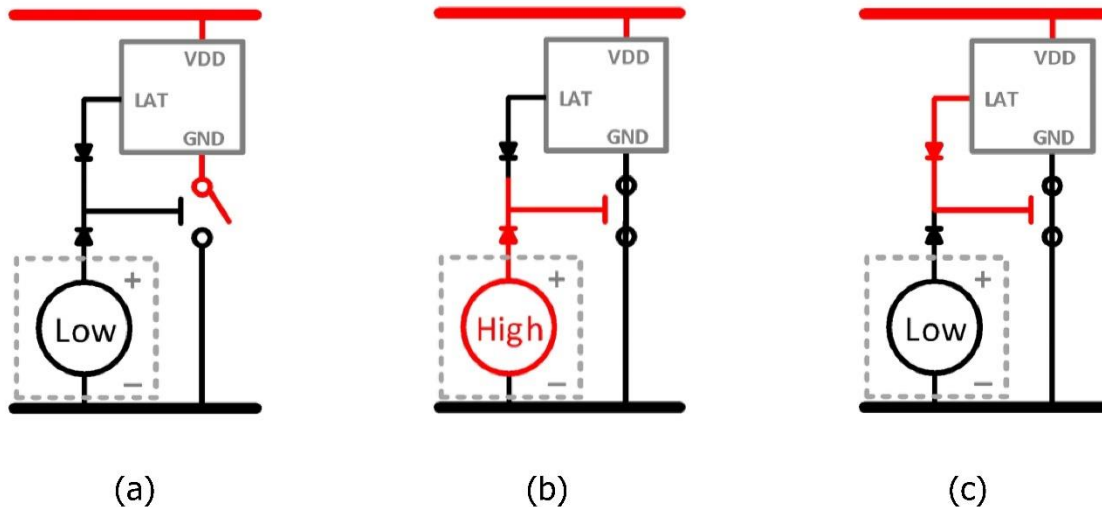

Operation of a footer switch. (a) The device ground is disconnected from supply ground in standby mode. (b) When the wake-up signal goes high, the device ground is connected to supply ground, and the device receives power. (c) The device must latch the gate of the footer switch to remain powered, even if the wake-up signal goes low. To deactivate, the latch goes low.

Source: Daniel Gerber

## Header Switch

The header switch is a high-side PMOS sleep transistor alternative, as shown in Figure 10. This configuration is useful in applications that require a fixed-ground reference between the device and wake-up signal. In this topology, the wake-up signal activates a low-power NMOS, which then activates the gate of the header switch PMOS through a pull-up resistor (Chao and Harrison 2008).

**Figure 10: The Header Switch**

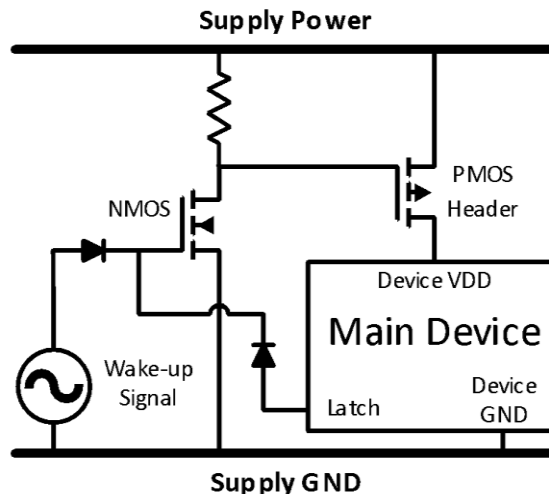

A header switch topology. The wake-up signal activates an NMOS, which activates the PMOS header switch through a pull-up resistor.

Source: Daniel Gerber

## Cascoded Header Switch

The cascoded header is a variant of the header switch that is ideal for a high-supply voltage, such as the  $\sim 170\text{-V}$  output of a bridge rectifier on 120-volt AC power. It was developed in this work explicitly for the laser-based zero-standby solution described in Chapter 4. As shown in Figure 11, the cascoded header uses two NMOS transistors to activate the header switch gate. The top NMOS (M2) is a high-voltage device, and the bottom NMOS (M1) is a low-voltage device with a low gate-threshold voltage. This combination of devices allows for a low-gate threshold while simultaneously withstanding a high supply voltage.

**Figure 11: The Cascoded Header Switch**

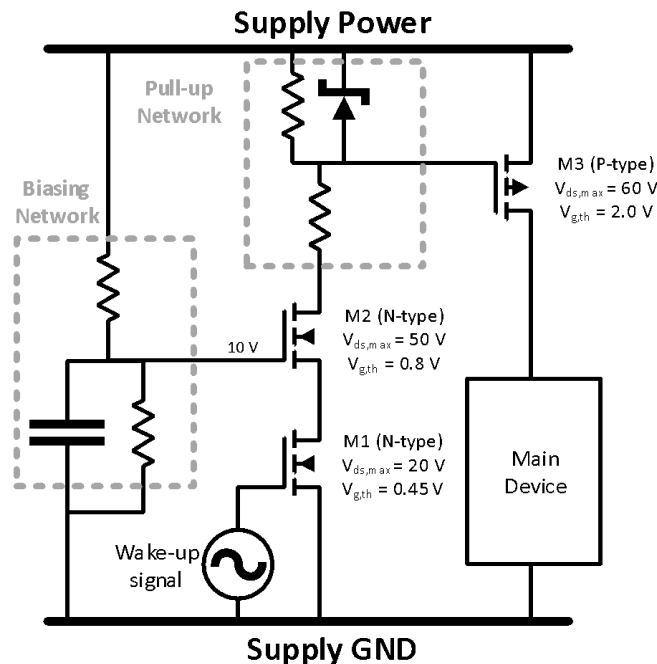

A cascoded header switch topology with example transistor values for a 48 V DC supply. The biasing network functions to bias the gate of M2 at 10 V. The pull-up network contains a Zener diode to protect the gate of the header switch M3. The latch signal is not shown.

Source: Daniel Gerber

## 4. Optical Wake Up

### Infrared Wake-Up Signal

Several papers propose infrared (IR) energy harvesting from a remote as a wake-up drive signal. As shown in Figure 12, this method involves a high-power transmission to wake the device, and low-power signaling for all other functions. Yamawaki and Serikawa describe a method for driving the footer switch using IR energy harvested from a photodiode (Yamawaki and Serikawa 2015b, 2015a). Although the intended application was for set-top boxes, their work can extend to any device that requires line-of-sight activation such as lights, ceiling fans, and window coverings. The main drawback of this method is in the wide-beam nature of the IR light-emitting diodes (LEDs), which disperses much of the transmission power. As a result, the transmission range for consistent successful wake-up was limited to 3 meters, which poses a practical constraint. Kang et al. proposed a similar method that involved using a 15-MW IR

laser to drive a relay, but that work yielded an even smaller range of 2 meters (Kang et al. 2011). In all cases, the wake-up duration is in milliseconds.

**Figure 12: Proposed IR Energy Harvesting Method**

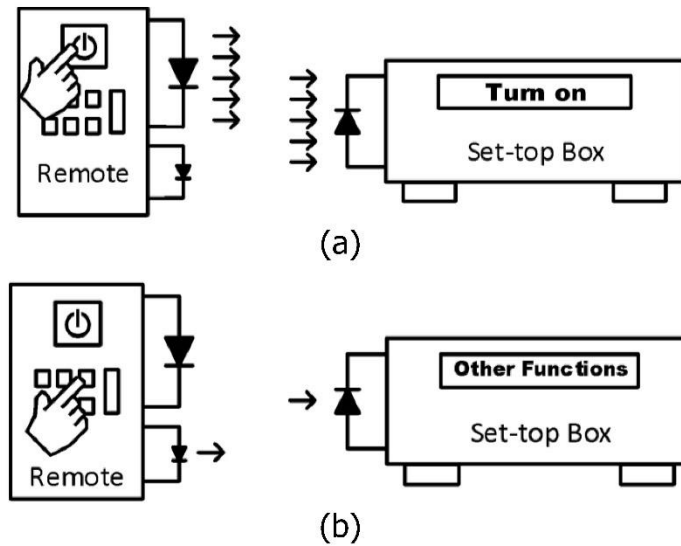

Proposed IR energy harvesting method for set-top boxes. (a) When the power button is pressed, a high power IR signal is transmitted to wake the device. (b) Once the device is awake, ordinary low-power IR signals can be used for all other functions (e.g., changing the channel).

Source: Daniel Gerber

The IR-based prototype discussed in this report is based on the architecture developed by Yamawaki and Serikawa (2015b, 2015a). As shown in Figure 13, this method uses a photodiode array at the receiver to harvest energy from a high-power IR transmission at 38 kilohertz (kHz).

**Figure 13: The Receiver for an IR-based Zero-Standby Supply**

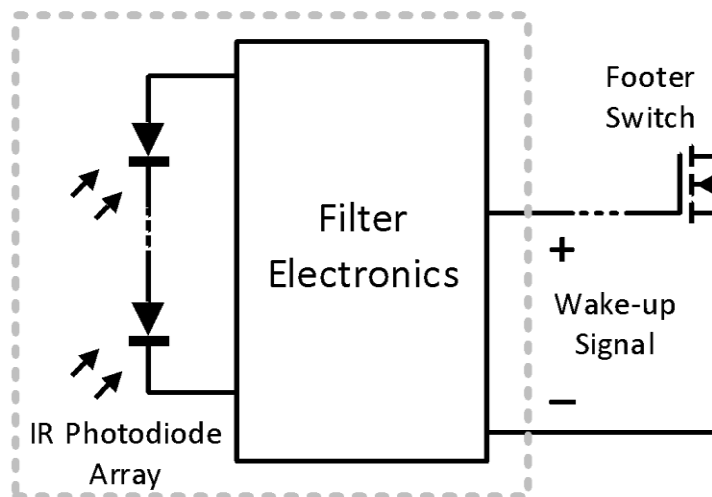

The receiver for a zero-standby supply with an IR-based wakeup signal. The photodiode harvests IR energy from the IR signal, which drives the gate of the footer switch.

Source: Daniel Gerber

The photodiode array generates an output voltage relative to the transmission strength and the number of photodiodes illuminated by the beam. To activate a typical mid-power 50-V footer switch, the photodiode array usually needs to generate about 0.5–0.8 volts. In this application, the output of the photodiode array is passed through a 38 kHz band-pass filter and rectified to provide an appropriate wake-up signal at the gate of a footer switch. As discussed in Chapter 3, the footer switch connects the device to ground, thus eliminating power consumption during standby.

The prototype shown in Figure 14 was developed to test the practicality of the IR-based zero-standby method. The transmitter provides 14-W pulses to four IR LEDs, and the receiver contains an array of 12 photodiodes. Although the prototype can successfully attain zero-standby power consumption, it has several practical shortcomings. First, the wide beam angle of the bulb-shaped IR LEDs limited the prototype’s reliable transmission range to 1 meter. Second, the IR LEDs must be well aligned with the photodiode array, despite their wide beam. Since IR emissions are not visible to the naked eye, it is difficult to manually make this alignment. Finally, the required transmission power approaches a level that becomes questionable for eye safety.

**Figure 14: Prototype of the IR-Based Zero-Standby Supply**

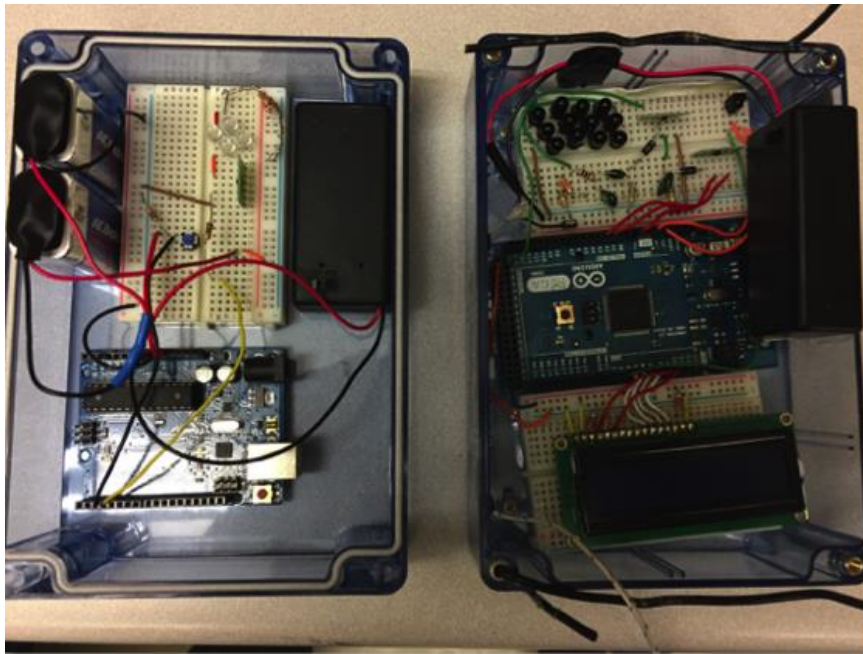

A prototype of the IR-based zero standby supply. The remote control with four clear IR LEDs is shown on the left, the receiver with 12 dark photodiodes and the device (LCD screen) are shown on the right.

Source: Daniel Gerber

### **Laser Wake-Up Signal**

A laser-based zero-standby supply was developed to address the IR method’s shortcomings. The main advantages of a visible-light laser are that it is easy to aim, and its narrow beam considerably increases the activation range. Similar to the IR method, the laser’s receiver harvests light energy to drive the gate of a footer switch. The main differences are in the front-end wake-up circuit. First, the laser’s receiver only needs a single photodiode to operate.



However, it can be difficult to dexterously aim the laser pointer at a single photodiode, and an array of photodiodes can still be helpful. Second, the laser's receiver requires a special front-end circuit to drive the gate of the sleep transistor.

The need for a front-end circuit is related to the safety concerns relevant to high-power lasers. Any laser with an instantaneous power greater than 5 MW (laser class IIIa) is subject to strict regulations. As such, the transmitter is limited to operate below 5 MW, which is similar to a common laser pointer. This presents a challenge since most affordable photodiodes cannot generate the requisite gate-drive voltage from 5 MW. For example, a SFH206K photodiode can only generate up to 0.5 V, whereas a typical 50 V NMOS has a gate-threshold voltage of 0.8 V. Two front-end circuit topologies were developed to address this challenge.

The first topology is the cascoded header switch in Figure 11, which allows the bottom NMOS to have an extremely low gate-threshold voltage. The gate threshold of the Si3460DV NMOS is 0.45 V, which can be activated by the 0.5 V photodiode wake signal. Nonetheless, this topology leaves little margin for error, and an angled or diffracted illumination may fail to activate the device.

The second topology utilizes a charge pump circuit to step-up the output voltage of the photodiode. The Dickson charge pump, shown in Figure 15, is particularly convenient in harvesting applications since it can be completely self-powered. In addition, the input voltage can be multiplied by several stages, allowing the voltage at the footer switch gate to be well above its gate threshold. Since the charge pump requires an AC input, the laser is pulsed at 1 kHz. The main drawback is in the Schottky diode drop of 0.2 V, which causes each stage to be less efficient, ultimately increasing the overall hardware cost.

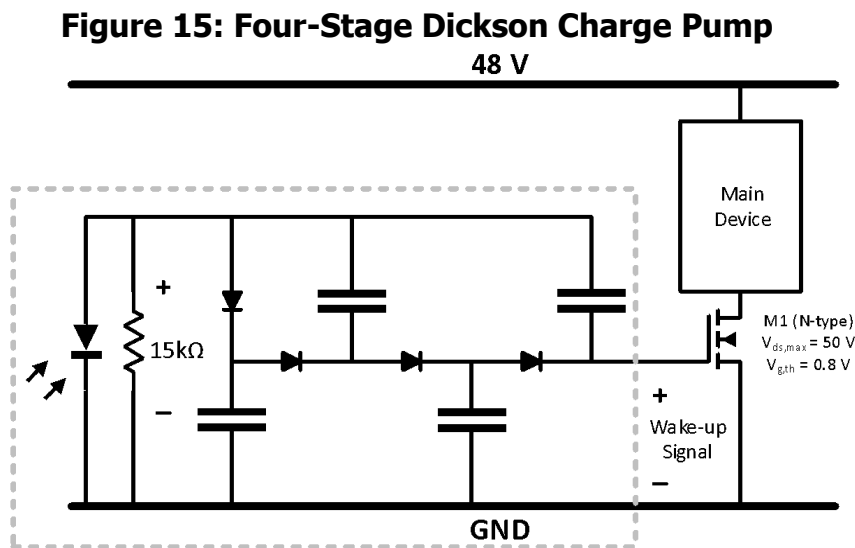

**Laser standby solution with a four-stage Dickson charge pump attached to an NMOS footer switch M1.**

Source: Daniel Gerber

The prototypes shown in Figure 16 were built from inexpensive off-the-shelf components. Both of the laser-based prototypes can successfully activate a sleep transistor. The charge pump battery-powered lamp in Figure 16a was demonstrated at a transmission range of 25 m.

Overall, the laser-based method is potentially useful in reducing standby-power consumption in set-top boxes and other similar devices.

**Figure 16: Prototypes of the Laser-Based Zero Standby Supply**

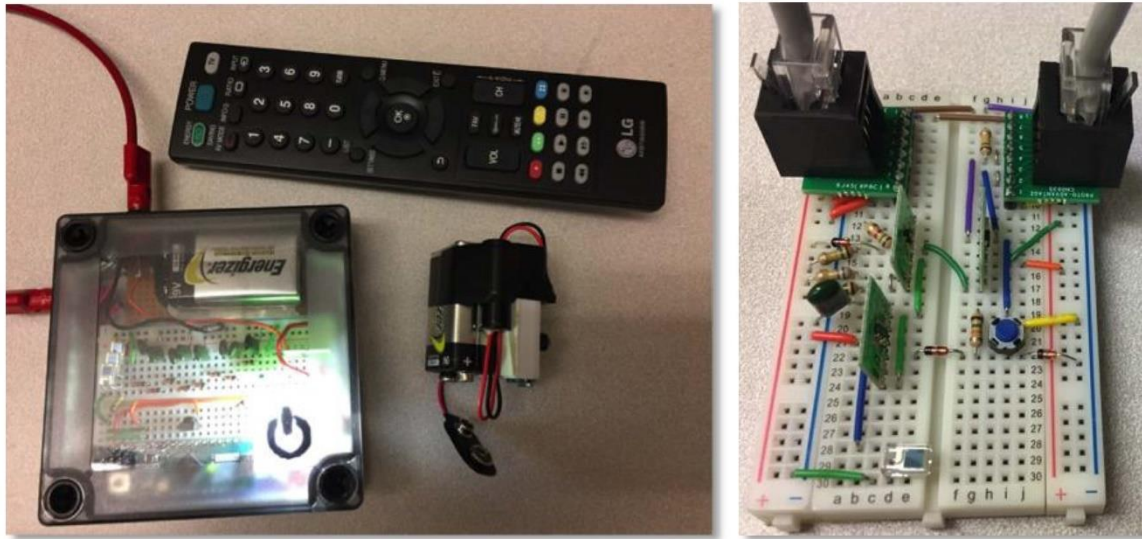

(a)

(b)

The prototypes of the laser-based zero standby supply. (a) The charge pump prototype in a battery-powered lamp. The receiver is shown on the left, the laser on the right, and the low-power IR remote on the top, which would contain the laser in practice. (b) The cascaded header prototype in a 48 V power over Ethernet (PoE) application.

Source: Daniel Gerber

The laser-based zero-standby topologies may also prove useful in fiber and optical-link applications. Fiber communication transmits at a similar power level, and benefits from a wave-guide to focus the light. Further research is required to verify the applications of any fiber-based zero-standby solution.

## 5. Wake-Up Radio

A radio frequency (RF)-based wake-up signal is appealing due to the proliferation of wirelessly connected technologies that contain a built-in transceiver and antenna. Various ideas have been proposed for ambient or broadcasted RF harvesting (Kim et al. 2014; X. Lu et al. 2015). However, in most cases, the amount of transmission power required for pure RF harvesting makes it difficult to justify its use in plug-load applications.

For plug loads, the wake-up radio (WuR) is a more appealing method. WuRs are a family of ultra-low-power receivers designed solely to wake the main device from sleep mode (Demirkol, Ersoy, and Onur 2009; Magno et al. 2014). At present, most research in WuRs is applied to prolonging battery life in remote IoT applications. Some studies, such as Umeda and Otaka, propose the application of WuRs in plug loads (Umeda and Otaka 2007). As shown in Figure 17, WuRs are electrically separate from the device's primary high-power transceiver but share the same antenna. They can be programmed to be individually addressable, thus allowing the wake-up broadcast to wake only individual devices.

**Figure 17: Wake-Up Radio System**

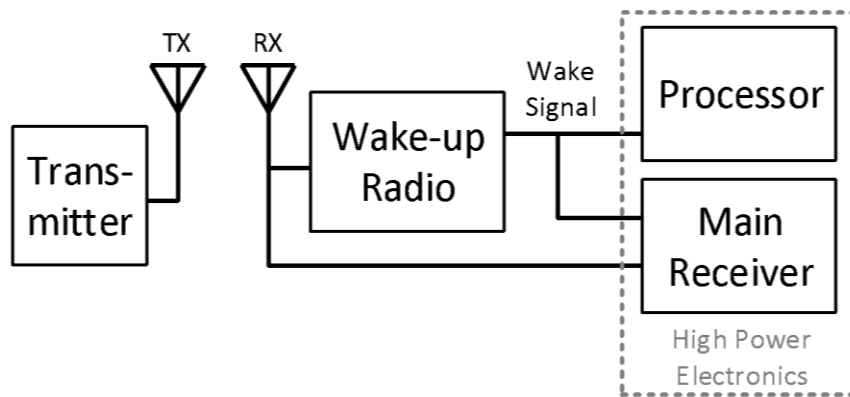

**The microwatt wake-up radio can share an antenna with the high-power transceiver.**

Source: Daniel Gerber

Modern and future trends in electronics suggest that many devices and appliances will be wirelessly IoT connected. Even set-top boxes and remotes have begun to transition from IR to WiFi-based communication. Although the WuR does not strictly allow for zero-standby consumption, its microwatt consumption is practically negligible. At present, WuRs are most commonly used in battery-powered wireless applications. This research aims to demonstrate that WuRs can also be employed for standby-power reduction in plug loads.

As shown in Figure 18, plug load WuRs can toggle a footer switch similar to the IR- and laser-based methods. Unlike these methods, the WuR requires a constant current of several microamps. While the wall adapter can provide this current, many converters do not operate efficiently at low power. In addition, the wake-up radio might operate at a lower voltage compared to the rest of the device electronics. As such, this work recommends powering the WuR using the burst-mode techniques discussed in Chapter 2. With these modifications, the WuR is an effective way to reduce standby power in wirelessly connected plug loads.

A prototype for the method in Figure 18 was developed using the AS3932 WuR chip. This prototype, shown in Figure 19, uses near-field magnetic coupling at 125 kHz to turn the device on from across the room. However, its range is relatively limited at 3 m, and is heavily affected by metal shielding. Nonetheless, various RF techniques have demonstrated that the AS3932 can operate with an 868 MHz (or even higher) input at a range of 50 m (Gamm et al. 2010; Oller et al. 2013). With proper design of the antenna, board, and RF down converter, the prototype in this work can be upgraded for a similar frequency and range.

**Figure 18: Wake-Up Radio Operational Block Diagram**

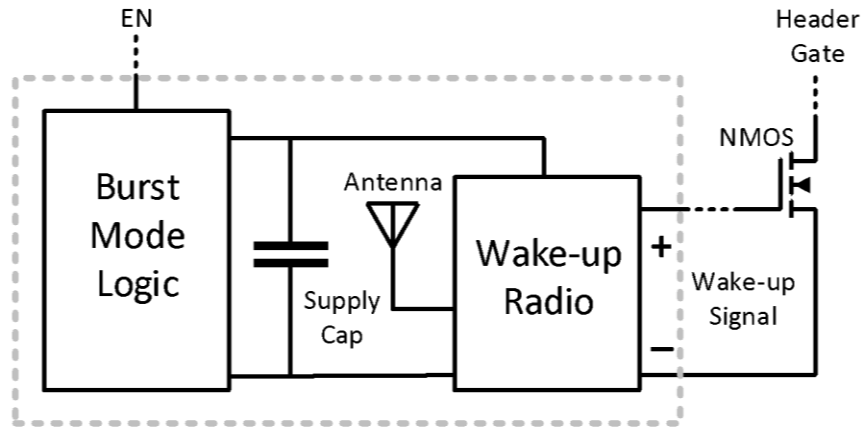

Block diagram for how the WuR can be used to reduce standby power consumption in plug loads. The supply capacitor and burst mode logic provide a constant supply of micro amp current to the wake-up radio. If the WuR needs to communicate with the main device, the circuit will require a header switch to maintain a common ground for the communication signals.

Source: Daniel Gerber

**Figure 19: Wake-Up Radio Prototype**

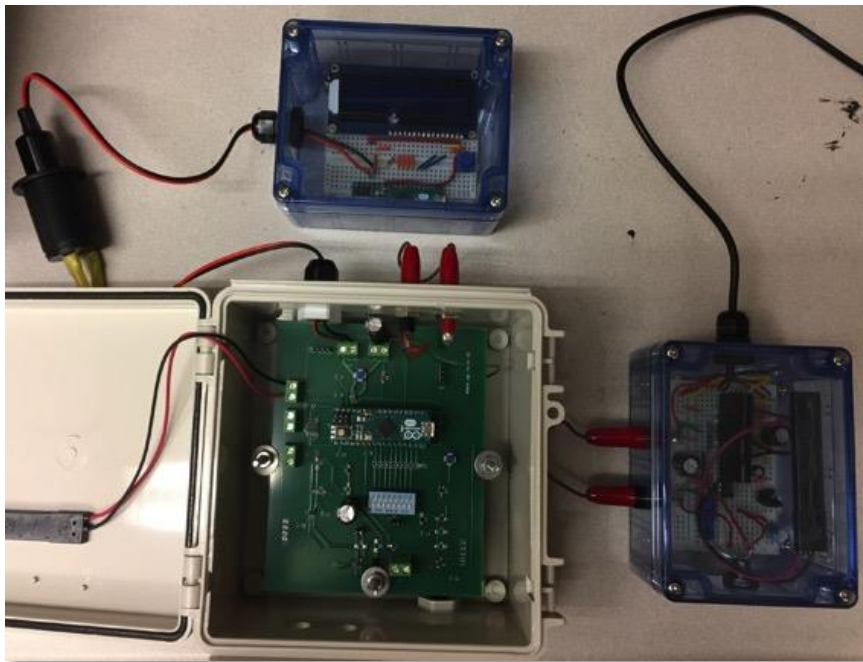

Prototype of the WuR method for standby power reduction. Includes the transmitter (right), receiver (bottom left), and display load (top). All of the receiver board components can be integrated into the WuR except for the electrolytic supply capacitor.

Source: Daniel Gerber

This study recommends the WuR for all wirelessly connected products, both battery-powered and plug loads. Nonetheless, addressing protocols must be standardized before WuRs can be broadly used. One possibility is for the WiFi access point to become a centralized broadcasting unit. Remotes could request the router to broadcast a wake signal addressed to the remote's

specific target. Alternatively, IoT devices with occasional periodic functions could request the router to schedule a periodic wake-up.

This work also recommends integrating burst-mode logic into commercial WuR products. Burst mode would provide a convenient and efficient means of powering the WuR and help expand its application in many types of products.

## **6. Conclusion**

Improvements to power supplies have drastically reduced standby consumption over the last 20 years. However, the need for standby-power reduction persists due to the increasing population of power-connected devices with standby modes. Since modern electronics are very diverse in application and requirements, this work suggests a portfolio of solutions to tackle standby consumption. Several such solutions were presented and prototyped. The first demonstrates the value of burst mode for lightly loaded converters. The second uses IR energy harvesting to activate a footer switch to wake the device. The third harvests visible light energy from a laser pointer, and the fourth solution uses a wake-up radio to activate a header switch. As IoT technology transitions and loads become small and numerous, intensive standby reduction will be crucial for energy-efficient products.

This work demonstrates zero or near-zero standby power as technically feasible in several families of products. These solutions have both advantages and drawbacks and will require technical improvements and reductions in cost before they can be commercialized. In addition, the portfolio of solutions need to be broadened before standby power use can be confidently—and economically—eliminated.

# CHAPTER 3:

## Efficient, Direct, Direct-Current Devices

---

### 1. Background and Motivation

#### Motivation for Direct Current Distribution in Buildings

DC power distribution systems have become a recent topic in building energy research as a means to reduce electricity consumption. In the past, AC current was well suited to power nineteenth- and twentieth-century loads such as the incandescent lamp, resistive heating, and fixed-speed induction motors. However, with the proliferation of electronics, LED lighting, and variable-frequency drives (VFDs) for motor-driven loads, an increasing fraction of today's electric loads operates internally on DC (Garbesi, Vossos, and Shen 2011). In addition, the recent growth in on-site photovoltaic (PV) generation (Perea et al. 2017) and battery storage (GTM Research 2016) adds even more DC components to the building network. DC power distribution between on-site generation, storage, and loads can reduce losses in converting between AC and DC, leading to electricity savings across the board (George 2006).

Potential electricity savings from DC distribution systems in buildings have been addressed in numerous studies (AlLee and Tschudi 2012; Backhaus et al. 2015; Savage, Nordhaus, and Jamieson 2010; Denkenberger et al. 2012; Sannino, Postiglione, and Bollen 2003; Thomas, Azevedo, and Morgan 2012; Garbesi, Vossos, and Shen 2011; Engelen et al. 2006; Glasgow 2017; Hammerstrom 2007; Liu and Li 2014; Noritake et al. 2015, 2014; Paajanen, Kaipia, and Partanen 2009; Starke, Tolbert, and Ozpineci 2008; Willems and Aerts 2014; Gerber et al. 2018; Gerber et al. 2017; Frank and Rebennack 2015; Weiss, Ott, and Boeke 2015; Boeke and Wendt 2015; Fregosi et al. 2015). For the commercial building sector, reported savings vary widely from 2 percent (Backhaus et al. 2015) to as much as 19 percent (Savage, Nordhaus, and Jamieson 2010). Gerber et al. (2018) performed a series of highly detailed parametric simulations that varied solar and storage capacity in several equivalent AC and DC buildings. The results suggested that the highest savings occur in buildings with large PV and storage capacities, such as zero-net-energy buildings. An additional loss analysis revealed that low-power-load rectifiers contributed the most loss in the AC buildings. In general, the reported savings are highly dependent on the system converter efficiencies, the system topology and voltage levels, and the coincidence of generation and load.

Systems with 380-V DC distribution have been proposed and successfully implemented in data centers, where estimated savings range between 7 and 28 percent. These high savings are a result of loads that are predominantly electronic (AlLee and Tschudi 2012). Commercial buildings have seen several instances of early adoption for DC distribution systems, primarily in lighting applications (Fregosi et al. 2015; Nextek Power Systems n.d.; Wright 2016). Several other experiments developed DC loads and test beds to evaluate savings and power quality with DC (Weiss, Ott, and Boeke 2015; Boeke and Wendt 2015; Fregosi et al. 2015; Kakigano, Miura, and Ise 2010; Ito, Zhongqing, and Akagi 2004). Weiss et al. (Weiss, Ott, and Boeke 2015) modeled a 380-V DC system with measured efficiency data in a variety of loads and estimated the DC savings at 5 percent. Fregosi et al. (2015) performed a similar analysis on

lighting test beds with the Bosch DC microgrid, resulting in savings of 6 to 8 percent. Finally, Boeke and Wendt (2015) reported 2 percent measured and 5 percent potential electricity savings from an office LED lighting test bed at the Philips High Tech Campus, in Eindhoven, Netherlands. Many of these experimental DC loads and test beds exhibit substantially lower savings than those predicted by past analyses and simulations.

This work helps address the pressing need for the development of efficient DC loads. It aims to demonstrate savings with DC loads and suggests ways that experimental loads in DC test beds can be improved.

## **Previous Works in Direct Current Modification**

Currently, there is a small market for DC plug loads for recreational vehicle (RV) and boating applications (Vossos et al. 2017). These loads are often compact and designed for 12-V or 24-V DC from the vehicle's battery. In the next few decades, low-voltage DC solar home systems will penetrate the markets in developing countries that currently lack universal electrification.

Several previous works have prototyped DC plug loads for newly constructed DC buildings in the residential and commercial sectors. Many of these efforts create prototypes for a variety of DC appliances as a means to perform system or microgrid tests (Mishra, Rajeev, and Garg 2018; Ryu et al. 2015; Makarabbi et al. 2014; Noritake et al. 2015; Stippich et al. 2017). Recent research has produced DC prototypes in many end-use categories such as lighting (Weiss, Ott, and Boeke 2015; Boeke and Wendt 2015; Ryu et al. 2015; Makarabbi et al. 2014; Noritake et al. 2015; Stippich et al. 2017; Jhunjhunwala et al. 2016), motor loads (Ryu et al. 2015; Noritake et al. 2015; Stippich et al. 2017; Jahromi et al. 2014; Das et al. 2016; Chauhan et al. 2017; Yukita et al. 2017), electronics (Ryu et al. 2015; Makarabbi et al. 2014; Noritake et al. 2015; Stippich et al. 2017; Rani et al. 2016), and induction cooking (Makarabbi et al. 2014; Lucia et al. 2013).

Despite the wealth of research on developing DC loads, there are still several important gaps. First, many of the previous works compare AC and DC loads of different technologies. It has been common, for example, to compare a DC variable-frequency-drive motor appliance to an outdated AC induction motor equivalent. Second, many of the previous prototypes are not designed to operate at DC distribution voltages and require DC/DC converters at the input. Such practices neglect the many design optimizations allowed by DC power that can result in higher device efficiency and lower cost. Finally, most of the previous studies use prototype DC plug loads, but do so as a means to showcase another research topic such as a DC microgrid demonstration or a new control strategy.

This work aims to improve on previous works by focusing on the optimal development of DC loads. Although it demonstrates savings in various prototypes, the main goal is to suggest ideas and practices that can and should be implemented in future products. In addition, this work gives detailed explanations of the benefits of DC from the load perspective.

## **2. Direct Current Load Modifications**

### **Existing Direct Current Voltage Standards**

There are several considerations when selecting voltage for DC power distribution. Safety is a primary concern, and OSHA standard 1910.303(g)(2)(i) (OSHA 2015) considers voltages below 50

V AC or DC to be touch-safe (the UK IET BS 7671:2008 (BS 7671:2008) specifies it at 50 V AC and 120 V DC). Second, higher voltages require more insulation to protect against dielectric breakdown. Finally, low-voltage systems experience higher wire loss and voltage drop for any given power level and wire gauge. For a device with constant power requirements  $P_L$ , the current can be expressed as  $I = P_L/V$ . Since the wire loss decreases quadratically with the wire's voltage ( $P_w = I^2 R_w$ ), it is recommended that high-power devices be powered from high-voltage lines.

This work investigates several existing or emerging standards for DC plug voltages:

- USB Type C: 5-20 V, 100 W
- PoE: 48-57 V, 91 W
- EMerge Alliance Data/Telecom Center Standard: 380 V

USB-C is emerging as the single-standard technology to power any low-voltage device. Its point-to-point power delivery architecture allows for simultaneous power and communications. Power over USB-C strictly adheres to the USB power delivery (USB-PD) protocol ("Universal Serial Bus Power Delivery Specification, Version 1.2, Revision 3.0" 2018). USB-PD controllers are required for sending and receiving devices in order to transfer power at voltages greater than 5 V. Past USB-PD standards set the programmable voltage to 5 V, 9 V, 15 V, or 20 V. However, as of USB-PD 3.0 (2018), the port can now function as a programmable power supply (PPS) and output voltages between 3 V and 21 V with 20 mV increments. USB-C connectors contain 24 pins, of which 8 are for power, 2 are for dedicated USB-PD communications, and the rest are for data. USB is best suited for short-range power distribution such as a cubicle because of the voltage drop and wire loss inherent with low-voltage distribution.

Another competing USB protocol is Qualcomm Quick Charge (QC), which has voltage and power specs similar to USB-PD (Qualcomm, n.d.). QC works with traditional USB-A or B ports but requires use of data lines for power signaling communications. It also has a PPS capability with 200-mV increments (QC 3.0), allowing it to charge batteries much more quickly and efficiently. Although this fast-charging capability made QC very popular, USB-PD 3.0 now has much of the same functionality. Recent versions of QC also support USB-PD, and it is possible that the two standards will soon merge.

Power over Ethernet (PoE) nominally operates at 48 V, although the standard allows up to 57 V at the source to compensate for wire drop (Osorio et al. 2015; Petroski 2016; Johnston et al. 2012). The 802.3bt Type 4 standard allows PoE to transfer 91 W of power over Category 5 Ethernet cable using a four-pair power transfer mode. Currently, PoE is used in applications that require both power and communications, such as phones, cameras, and routers. Since many buildings are already wired with Ethernet cables, PoE offers one of the easiest ways for DC power distribution to enter the market. In addition, PoE operates near the Occupational Safety and Health Administration (OSHA) touch-safe limit (50 V), thus optimally minimizing wire loss while ensuring safety. While USB is best suited to power a workspace, PoE can extend to multiple rooms or even an entire residence.

The EMerge Alliance has established a high-voltage DC standard, with specifications for powering datacenters at 380-V DC (EMerge Alliance 2013; Geary et al. 2013; Becker and



Sonnenberg 2011). This standard allows for easy retrofitting since 380 V DC cabling has similar insulation requirements with 277 V AC. Besides datacenters, 380 V DC holds much promise for powering other types of high-capacity loads (such as large motors), and allows for efficient coupling with solar and storage power electronics (Gerber et al. 2018). Nonetheless, 380 V DC distribution presents new arcing issues in protection and breaker technology, which must be addressed before 380 V DC buildings can become common.

### **Devices that Benefit from Direct Current**

Internally, DC loads are classified as being direct-DC or native-DC, depending on whether the building distribution is DC or AC, respectively (Backhaus et al. 2015). Direct-DC loads connect to the DC building distribution either directly or through a DC-DC converter. Native-DC loads always require a rectifier to interface with the AC building network.

This work further classifies loads based on how they can benefit from an interface to a DC distribution network (Figure 20). Common plug loads are classified as follows:

- **DC-connected:** The internal DC stage of these loads can be connected or hardwired directly to the DC distribution if properly designed. A direct-DC input would bypass the input voltage conversion (and/or rectification) stage, thus allowing for savings in efficiency and cost. As such, these loads stand to receive the greatest benefit from DC distribution.
- **DC-converted:** The internal DC stage of these loads requires a DC-DC converter in order to connect to the DC distribution at the proper voltage level. However, for most loads, the direct-DC version greatly outperforms its native-DC counterpart in efficiency, cost, and size. As such, these loads stand to receive some benefit from DC distribution.
- **DC-indifferent:** The load can be hardwired to an AC or DC distribution with equivalent cost and efficiency. These loads are equivalently efficient with AC or DC.

**Figure 20: Categorization of Loads by Benefit from Direct Current Input**

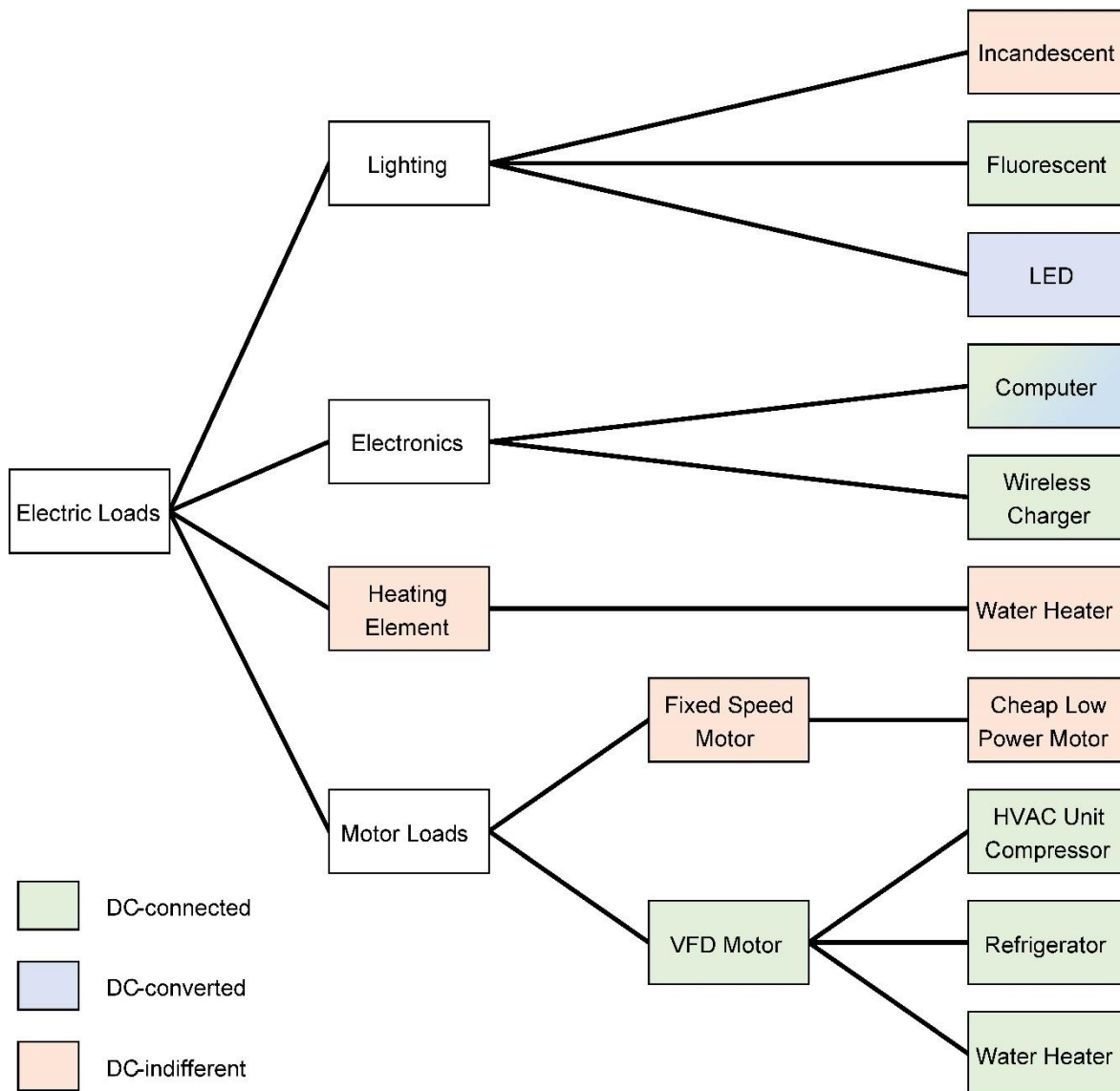

**DC-connected loads have an internal DC stage that can be connected or hardwired to DC distribution. DC-converted loads require an input DC/DC converter, but still benefit from a DC input. DC-indifferent loads do not benefit from a DC input.**

Source: Daniel Gerber

### **Direct Current-Connected**

DC-connected includes loads with a fixed internal DC bus, many of which require AC power at a frequency different from the 60 hertz (Hz) mains. These loads include variable frequency drive (VFD) motors and wireless power transfer (such as wireless charging).

VFD motor loads contain a brushless DC motor, which is essentially an inverter-driven induction motor. They are frequently used in control-heavy applications and have become commonplace in compressors for cooling and heating. Due to their efficiency benefits, VFDs will eventually replace fixed-speed motors in air conditioners, refrigerators, heat-pump air and water heaters, ventilation fans, and pumps (Saidur et al. 2012; Rooks and Wallace 2004; Didden et al. 2005). For this reason, fixed-speed motors are not considered in this study. As

shown in Figure 21a, native-DC VFD motors require a rectification stage for the 60-Hz AC input. The output of the rectifier is stored on a DC capacitor bus, which powers a set of inverters that supply the stator coils with variable frequency AC. In well-designed direct-DC VFDs, the DC capacitor bus could be connected directly to the DC distribution, as shown in Figure 21b. A direct connection bypasses the rectification stage, thus allowing for savings in efficiency and cost. In addition, the DC capacitors no longer have to filter the 120 Hz AC power ripple and can be reduced depending on the inverter switching noise.

**Figure 21: Block Diagram of a Variable Frequency Drive Motor**

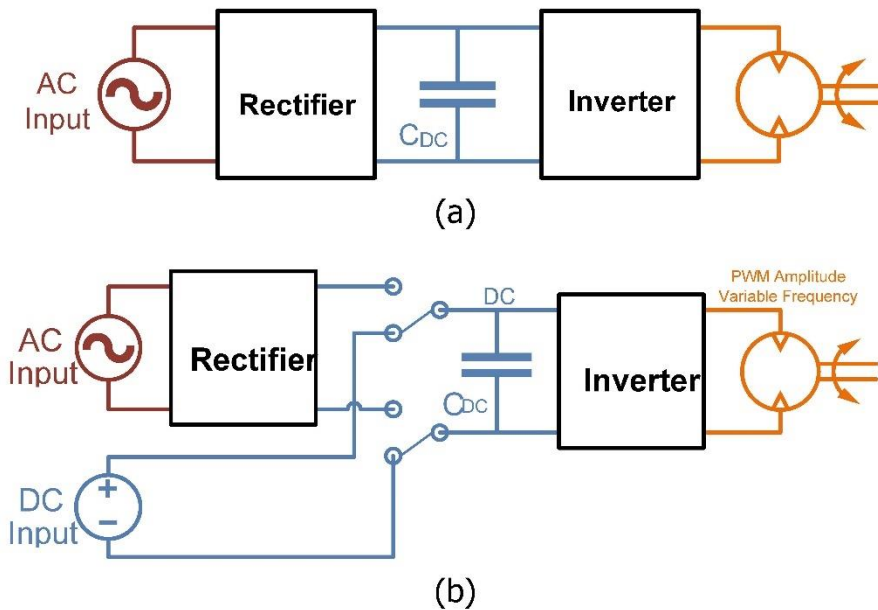

**Block schematic of a VFD motor, as present in the refrigerator and bathroom fan. The inverter is powered from an internal DC stage (blue), and outputs AC at a variable frequency (orange). (a) A rectifier is required to convert 60 Hz AC (red) to DC. (b) A proposed modification, with multiplexed AC and DC inputs.**

Source: Daniel Gerber

Wireless power (such as charging a phone) requires the production of AC at a frequency much higher than 60 Hz. In this way, wireless power transmitters are structurally similar to VFDs: they contain a rectifier, a DC stage, and a power amplifier (similar to an inverter). The power amplifier outputs AC power at the resonant frequency of the antenna. Transmitters are present in any wirelessly connected plug loads, including routers, computers, and IoT devices. In addition, wireless chargers and induction stoves employ near-field wireless-power transfer. Like VFD motors, wirelessly powered devices can all benefit from a DC input.

Inverter-based topologies can also be found in other applications such as electronically ballasted fluorescent lamps. The fluorescent lamp driver uses a resonant AC output to start the lamp, and then uses variable frequency AC for current control.

### Direct Current-Converted

DC-converted includes current-controlled loads and loads with multiple internal busses. LEDs are a current-controlled load, since their luminosity is nearly proportional to their current. As such, the LED driver is necessary, even with DC distribution. However, the efficiencies of DC

LED drivers can often be found in the 95–98 percent range, whereas AC LED drivers often exhibit 86–93 percent efficiency (Gerber et al. 2018; Fregosi et al. 2015). DC LED drivers may be less expensive because they do not have to rectify the AC input, apply power factor correction (PFC), or cancel the 120-Hz AC power ripple. They are also more reliable since their capacitor requirements are lower than AC drivers.

Computers are examples of DC-converted devices with multiple internal busses that power different parts of the computer. Even when powered from DC distribution, computers require multiple DC-DC converters to power the various internal DC-power rails. However, it also can be argued that many computers could be designed with a direct DC connection to the computer's internal DC bus. For example, laptops use a wall adapter to convert 120 V<sub>RMS</sub> AC to a single DC output voltage, usually in the range of 14–20-V DC (varies by model). A low-voltage DC input would remove the need for a wall adapter, thus allowing for benefits similar to other DC-connected devices.

### **Direct Current-Indifferent**

DC-indifferent includes heating elements and fixed-speed motors. Resistive heating elements are often found in water heaters, ovens, and incandescent bulbs. These devices can be hardwired to an AC or DC distribution without any benefit to either. Fixed-speed motors are often found in inexpensive and inefficient motor loads such as fans. In an AC system, these loads are often implemented as brushed, universal, induction, or synchronous motors. In a DC system, simple motor loads would likely use a brushed DC motor. Brushed DC motors are inefficient and require more maintenance due to their commutating brushes. While AC induction motors are more efficient, they have lower power quality.

### **Experimental Method**

This work examined several types of electric loads, which were selected to represent a wide range of end uses and internal component types. The loads were a wall adapter, bathroom fan, refrigerator, LED task lamp, and LED zone lighting rig. The wall adapter represents electronics, in which localized conversion between 120 V AC and low-voltage DC is a common necessity. The refrigerator represents plug loads with a compressor. High-efficiency refrigerators contain VFD motors, whose DC capacitor stage can be directly connected to the DC distribution. The bathroom fan represents ventilation units. Modern high-efficiency ventilation fans use VFD motors with multi-speed control. The task lamp and zone lighting rig together represent the lighting end-use category.

The prototypes and modifications were intended to demonstrate savings with a direct-DC input. As such, the prototypes were all designed to leverage DC input to reduce the number of conversion stages. The means of demonstrating savings varied by load and included measuring input power consumption, nominal operating efficiency, and efficiency curves. Efficiency measurements used  $\eta = P_{out}/P_{in}$ , where  $P_{out}$  is the power measured at the device's internal DC stage, and  $P_{in}$  is measured at the AC or DC input.

### 3. Wall Adapters

#### Modifications for Direct Current Input

Wall adapters provide low-voltage DC to many household plug load electronics. With the emergence of the Internet of Things, electronics are trending toward widely distributed low-power units. DC distribution is attractive because it eliminates the wall adapter, improving overall cost and efficiency. The wall adapter must first rectify the 120 V AC input to 170 V DC, and then step the 170 V DC rectifier output down to the relatively low 5–20 V DC appropriate for electronics. Low-power wall adapters with a high DC/DC conversion ratio are often very inefficient. As of February 2016, the United States Department of Energy (DOE) requires wall adapters to adhere to the Level VI efficiency standard (CUI Inc, n.d.; SL Power Electronics, n.d.). For Level VI, the highest specified efficiency requirement is 88 percent (varies with power), which leaves plenty of room for improvement.

This work presents efficiency measurements for several wall adapters, most of which have a USB-C output at 5-20 V DC. The measured efficiency represents the losses for native-DC electronics. As shown in Figure 22, this work considers direct-DC electronics to be DC-connected and assumes that the DC distribution can provide the correct voltage to the device's internal DC bus. In this sense, the energy savings with DC are equivalent to the wall adapter's measured loss. Other more realistic scenarios may require a DC wall adapter, which is further discussed in following sections.

**Figure 22: Direct Direct-Current Wall Adapter Modification**

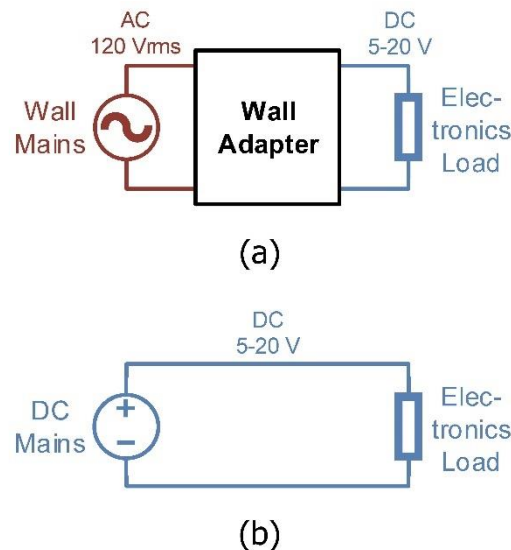

Two different means of powering the internal DC bus in electronics. (a) Native-DC electronics require a wall adapter. Present and future wall adapters will have a USB-C output at 5–20 V. (b) This study considers direct-DC electronics to be DC-connected.

Source: Daniel Gerber

#### Experimental Prototype and Results

The five USB-C wall adapters, shown in Table 5, vary in power capacity and quality. These adapters are loaded with a 5 V Anker Powerpack battery and a MacBook that attempts to

request up to 20 V. The efficiency is calculated from 10-minute measurements of the input and output energy.

**Table 5: Wall Adapter Efficiency**

<b>Adapter</b>	<b>Output Voltage (V)</b>	<b>Efficiency (%)</b>	<b>Average Measurement Output Power (W)</b>
Choetech 15 W	5	84.73	15.7
Pixel 18 W	5	87.18	11.0
	9	88.24	17.6
Anker 30 W	5	90.82	10.7
	20	91.22	29.2
Choetech 39 W	5	87.15	10.4
	15	91.96	37.7
Macbook 87 W	5	89.92	10.6
	20	94.91	59.8

Source: LBNL

### **Discussion**

The results show that wall adapters contribute considerably to the AC system loss. Realistically, electronics in a DC building also require a DC/DC conversion stage, since the distribution voltage is usually higher than the 5–20 V suitable for electronics. For example, a 380-V DC building would require a USB charging station to have an internal 380/5 V DC/DC converter. Nonetheless, there are several practices that would allow considerable savings with direct-DC electronics.

In general, high-power converters are more efficient than their low-power equivalents. AC wall adapters exhibit the use of many distributed low-power converters. However, DC distribution allows for centralizing the conversion in a high-power charging station, as shown in Figure 23a. Such charging stations could be mounted in a cubicle to power all the electronics in the workspace. They could use high-power DC technology such as an 800 W chip with 8–13 V output that peaks at 97 percent efficiency, the Vicor BCM6123xD1E1368yzz. Of course, an additional conversion stage may be necessary to ensure that each USB-C output adheres to the USB-PD specifications.

**Figure 23: Direct-Direct Current Wall Adapter Discussion**

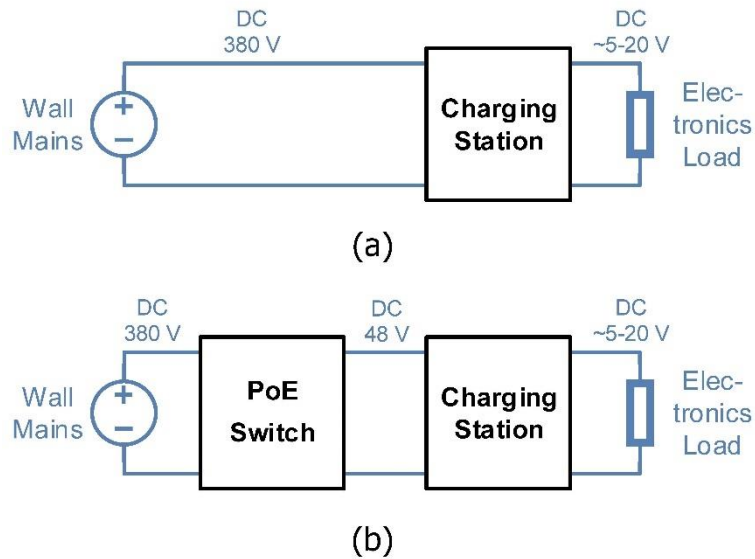

Two ways to power direct-DC electronics in a 380 V DC building. (a) The charging station performs a conversion from 380 V DC, and also outputs at the requested voltage of each USB-C port. This may be most efficient in two separate DC/DC conversion stages. (b) A PoE switch performs a 380/48 V DC conversion, and the charging station steps-down from 48 V DC to each desired port voltage.

Source: Daniel Gerber

Alternatively, the charging station could be designed for a 48 V DC input, as shown in Figure 23b. 48 V charging stations may be advantageous in both safety and applicability to residential 48 V DC networks. In Figure 23b, the PoE switch can contain a fixed-conversion 380/48 V DC unit such as the Vicor BCM6123xD1E5135yzz, a 1,750 W chip with a staggering 98 percent efficiency. The charging station would contain an efficient step-down converter for each USB-C output (Rani et al. 2016). The design of such a charging station is left for future work.

## 4. Bath Fan

### Modifications for Direct Current Input

VFD loads have an internal DC capacitor stage that buffers the inverter. The proposed modification, shown in Figure 24b, would add a DC-connected input directly to the DC capacitor stage. Such a modification is easiest when the device's nominal DC capacitor voltage is equal to one of the standard DC voltages. Electronic components can be damaged when the input voltage is greater than the device's nominal DC capacitor voltage, and the stator coils may be overheated when the input voltage is too low.

**Figure 24: Direct-Direct Current Bath Fan Modification**

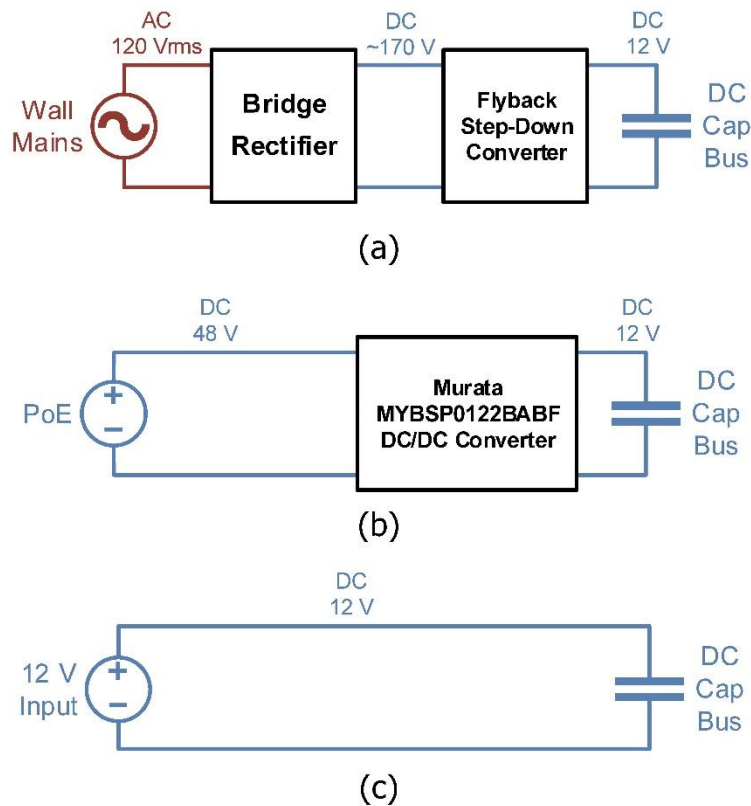

Methods of providing power to the bath fan's DC capacitor bus and inverter stages. (a) The fan's original AC/DC rectifier board. (b) The DC-converted modification for 48 V PoE input, using a DC/DC converter. (c) A DC-connected modification for a hypothetical 12 V DC input. This configuration represents how DC input would be beneficial if the motor and inverter was designed for 48 V DC.

Source: Daniel Gerber

The nominal DC capacitor voltage of a Delta GBR80 bath fan (Figure 25) is 12 V. Although it could connect to USB-C, homeowners would seldom want to power their bath fan from a short-range USB-C connection. PoE is the practical alternative, but at 48 V, it is far outside the 12 V operating range of the fan's inverter. As such, the fan must interface with PoE through a 48/12 V DC/DC converter. The modification has no effect on the fan motor's speed or torque since the DC capacitor bus and inverter remain the same.



**Figure 25: Direct-Direct Current Fan Prototype**

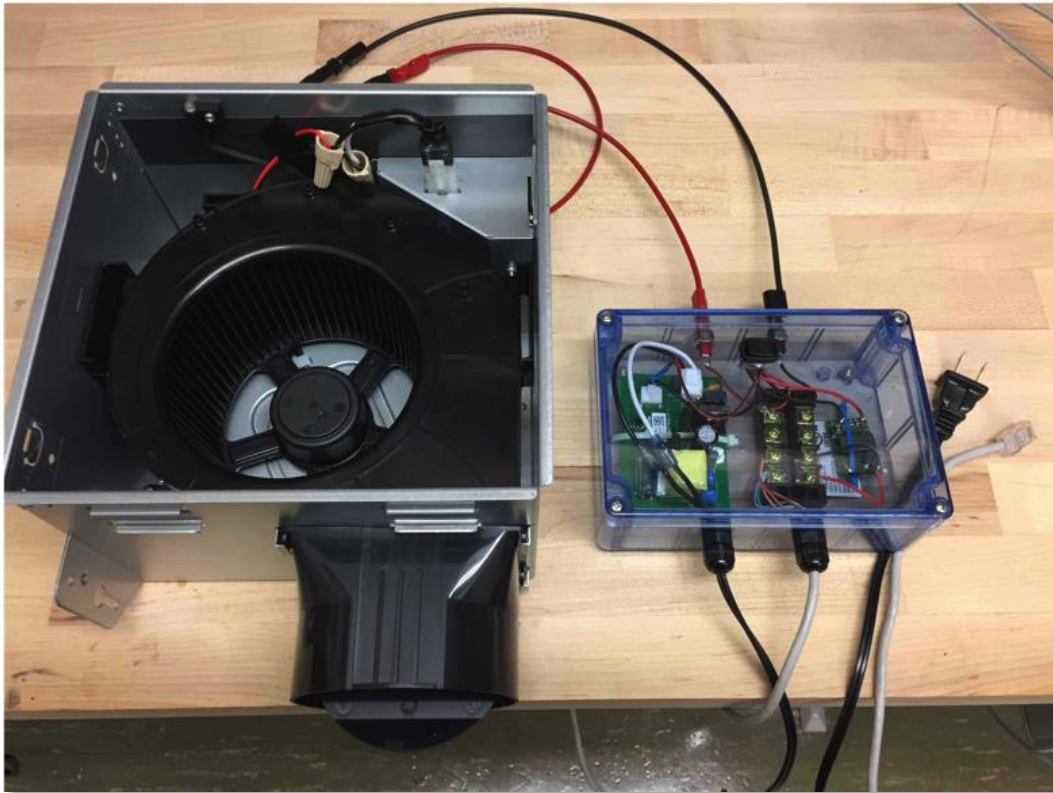

Prototype of the Delta GBR80 bath fan, modified to accept a PoE input. The blue box contains the AC and DC boards, with a switch to toggle between AC or DC input.

Source: Daniel Gerber

### **Experimental Prototype and Results**

The bath fan prototype, shown in Figure 25, was designed for a multiplexed AC or DC input, as previously depicted in Figure 21b. The blue electrical box contains both the original AC rectifier board and the 48/12 V DC/DC converter. The original AC board, shown in Figure 26a, used an isolated flyback topology to step down the input voltage to 12 V. The modified DC input used a 25 W Murata MYBSP0122BABF 48/12 V isolated DC/DC converter (~\$12), shown in Figure 26b.

The results suggest that DC input can improve the fan's power consumption. The efficiency curves in Figure 27 show that the DC/DC converter is up to 6 percent more efficient than the original rectifier board. Table 6 shows a decrease in the fan's input power with DC input. In addition, the fan draws even less power with a 12-V input, which represents the potential savings when the input voltage is matched with the nominal DC capacitor voltage. In this experiment, the exhaust valve was held open or shut to simulate a lightly or heavily loaded fan, respectively.

**Figure 26: Fan Boards**

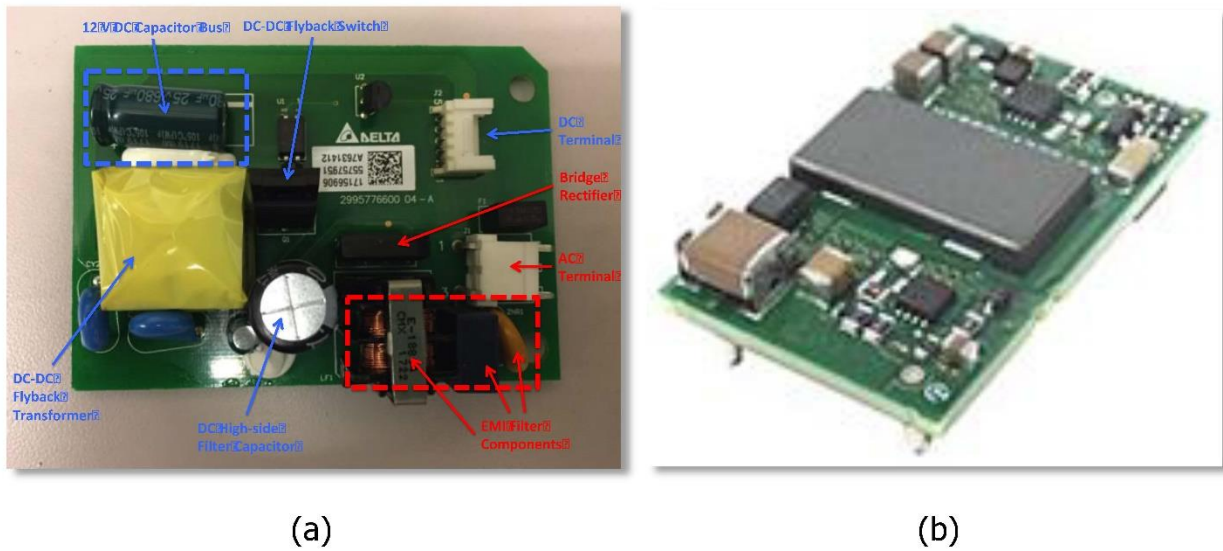

Input power conversion boards for the Delta bath fan. (a) The original rectifier board that converts 120 V<sub>RMS</sub> AC to 12 V DC. The board dimensions are 8 x 6 centimeters (cm). (b) A Murata MYBSP0122BABF 48/12 V DC/DC converter for interfacing the DC capacitor stage with PoE. The board dimensions are 3.5 x 2 cm.

Source: Daniel Gerber

**Figure 27: Efficiency Curves for the Bath Fan Boards**

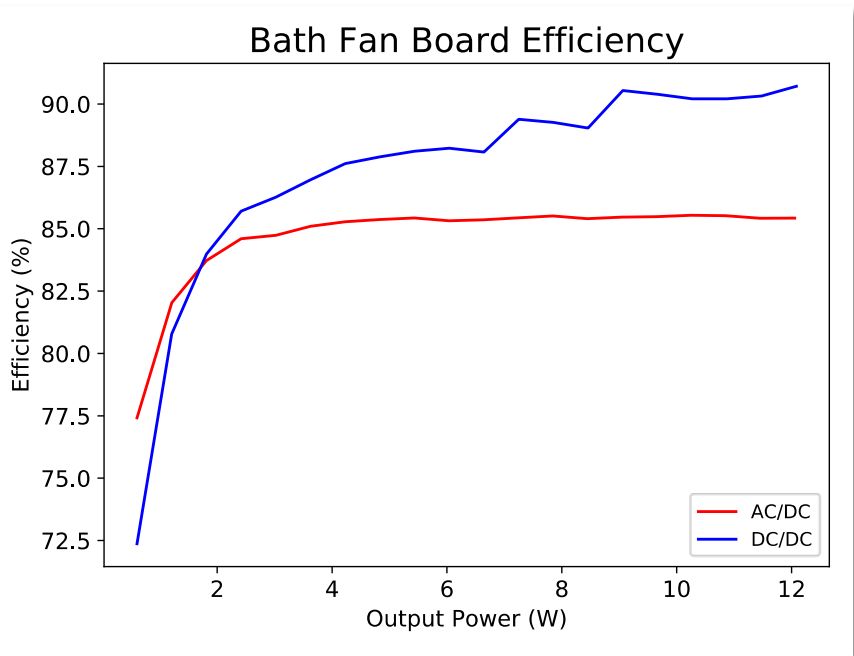

Source: Daniel Gerber

**Table 6: Fan Prototype Power Consumption**

Input Type	Conversion	Input Power Light Load (W)	Input Power Heavy Load (W)	AC Power Factor
Original 120 V <sub>RMS</sub> AC	AC/DC	7.75	9.01	0.64
DC-converted 48 V DC	DC/DC	7.43	8.65	N/A
DC-connected 12 V DC	None	6.6	7.72	N/A

Source: LBNL

## Discussion

There are two general reasons why the 48-V DC modification is more efficient than the original 120-V<sub>RMS</sub> AC converter board. First, the 48 V DC modification in Figure 24b only has a single 48/12 V conversion stage. In contrast, the 120-V<sub>RMS</sub> AC converter board in Figure 24a must both rectify 120-V<sub>RMS</sub> AC to DC, and then step-down to 12-V DC. Second, switching converters are generally more efficient with a smaller conversion ratio  $V_{out}/V_{in}$ , such as the 48/12 V conversion. Smaller conversion ratios allow switching converters to frequently conduct power from input to output. In contrast, large conversion ratios often require the switches to frequently block power, although parasitic losses still occur even while blocking. The 120-V<sub>RMS</sub> AC converter board uses a flyback topology to mitigate some of this loss by instead converting through the flyback transformer's turns ratio. However, inclusion of a flyback transformer adds cost, size, and a small amount of parasitic loss in the transformer and output rectification.

The 12 V DC input in Figure 24c is the most efficient of the three because it does not require any conversions. However, running 12-V power to the fan is impractical due to low-voltage wire loss. Nonetheless, the 12-V measurement shows that the highest savings occurs when the internal DC voltage of the BLDC motor is matched to the distribution voltage. If this motor were designed with a 48-V DC inverter, then the 48-V DC PoE modification could also be much more efficient. The next section shows how a BLDC motor can be redesigned to operate with a different internal DC voltage.

## Direct Current Capacitor Voltage in Brushless Direct Current Motors

Brushless DC motors are designed with an intended AC input voltage to the stator windings. The AC winding voltage is important because it dictates the inverter's DC input voltage from the DC capacitor bus. Direct-DC loads can be DC-connected if the nominal DC capacitor bus voltage is the same as the DC distribution voltage. This section shows how a motor's input voltage can be designed independently of its power rating, and can ultimately be designed so that the DC capacitor bus can seamlessly connect to the DC distribution. Figure 28 shows the winding area for two motors with equal input power and magnetic flux.

**Figure 28: Motor Winding Area**

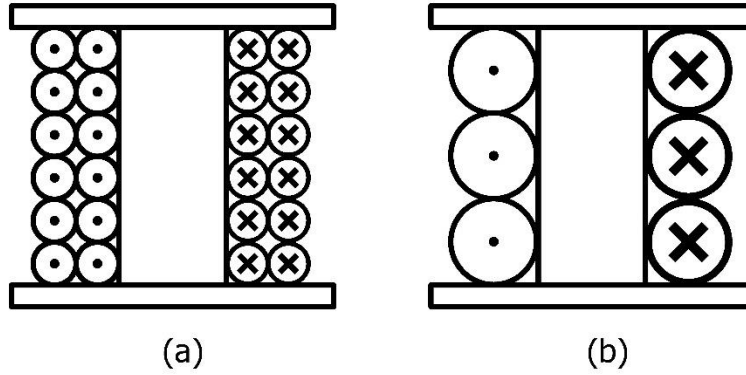

**Winding area diagram for two motors with equal input power and magnetic flux. The winding area in both motors is roughly equal. (a) A high-voltage motor that requires 12 windings, but they can be relatively thin. (b) An equivalent low-voltage motor only requires 3 windings, but they must be thick enough for the relatively high winding current.**

Source: Daniel Gerber

For a given application, assume that the motor's electrical input power  $P_{const}$  is specified and constant. Also assume that the motor's magnetic flux  $\phi_{const}$  is constant and directly related to the mechanical output power. The relations between the electrical stator windings and the magnetic core are shown in equations 1–3:

$$P_{const} = VI \quad (\text{Eq. 1})$$

$$\phi_{const} = \frac{NI}{\mathcal{R}_{tot}} \quad (\text{Eq. 2})$$

$$E = N \frac{d\phi_{const}}{dt}, \quad (\text{Eq. 3})$$

where  $V$  and  $I$  respectively are the winding's input voltage and current,  $N$  is the number of windings,  $\mathcal{R}_{tot}$  is the total reluctance of the magnetic core, and  $E$  is the back electromagnetic force (EMF) generated in the windings.

Consider a comparison between motors 1 and 2, which both have the same input power  $P_1 = P_2$ , and magnetic flux  $\phi_1 = \phi_2$ . However, the main difference is that the winding voltage of motor 1 is designed to be  $K$  times greater than that of motor 2. Since  $V_1 = KV_2$ ,  $I_1 = \frac{1}{K}I_2$ . If the two motors are specified with the same magnetic flux and core parameters, then  $N_1 = KN_2$ . In other words, the motor 1 requires  $K$  times as many windings, but the windings only pass  $\frac{1}{K}$  times as much current. Finally, it follows that  $E_1 = KE_2$  but since  $V_1 = KV_2$ , then each motor has proportionally as much voltage headroom, and each motor can attain the same maximum speed.

The overall result is that high-voltage motors use less current and have more stator windings than low-voltage motors of the same input power and flux. Since the low-voltage motor requires thicker windings capable of passing a higher current than the high-voltage motor. Nonetheless, the low-voltage motor requires fewer windings, and so the overall winding packing window is comparable between the two motors, as shown in Figure 28.

## 5. Refrigerator

### Modifications for Direct Current Input

Like the bath fan, the DC input modification of the 11 ft<sup>3</sup> LG LTNC11121V inverter-based refrigerator follows the procedure shown in Figure 21b and 29. The main difference is that the rectification stage in the refrigerator uses a Delon doubler (full-wave doubler), whose unloaded DC output is 340-V DC. As such, the refrigerator is modified to accept a 340-V DC input. Although not a standard DC voltage, this input represents what the efficiency and power draw would be at 380-V DC.

**Figure 29: Direct-Direct Current Refrigerator Modification**

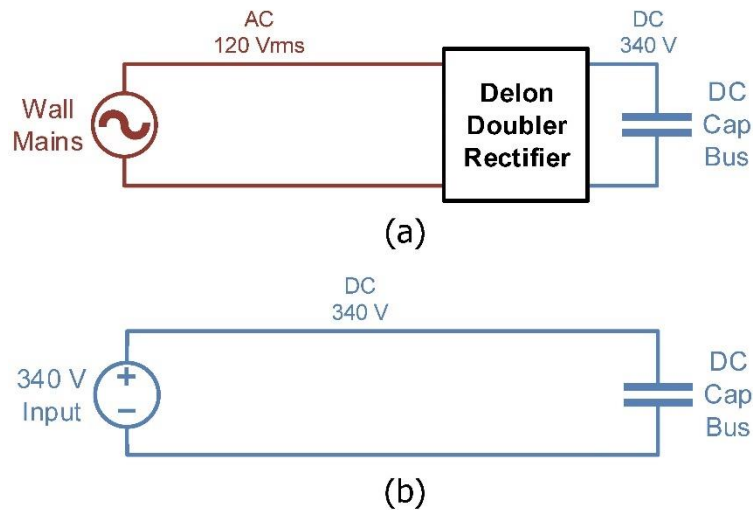

Methods of providing power to the refrigerator's DC capacitor bus and inverter stages. (a) The refrigerator's original AC/DC Delon doubler rectifier circuit. (b) The DC-connected modification for 340 V input, which approximately represents connection to a 380 V DC bus.

Source: Daniel Gerber

### Experimental Prototype and Results

The refrigerator prototype, shown in Figure 30, added a 380-V DC-connected input to the DC capacitor stage. The inverter board shown in Figure 31 contains an input electromagnetic interference (EMI) filter and protection components on the AC input. Although the prototype's DC input did not include these protective elements, it did contain a thermistor that protected the DC capacitors from over-current at startup. In this experiment, the refrigerator's defrost coils were deactivated, and the power was drawn solely by the compressor and electronics.

The efficiency of the rectification stage in Figure 29a was determined as  $\eta = P_{out,DC}/P_{in,AC}$ , where  $P_{in,AC}$  and  $P_{out,DC}$  are the power in and out of the rectifier, respectively. The average efficiency was 99 percent over 50 measurements with power ranging from 50-W to 80-W. There was little to no correlation between power and efficiency in this range. The extremely poor AC power factor was 0.65, and was caused entirely by harmonics.

## Discussion

The refrigerator barely benefited from a high-voltage DC input, since bypassing the rectification stage only saved 1 percent of the input power. LG designed the motor to operate natively off the 340-V output of the Delon doubler rectifier. As previously discussed, this means that the compressor windings use low current and a large number of turns. While the high-340 V operation is extremely efficient, its main drawbacks are its hardware size and cost, as can be inferred from the power components in Figure 31. In contrast, many low-voltage DC refrigerators such as the Danfoss 101N0212, shown in Figure 32, can make do with smaller electronics. This inverter board operates on 24-V DC, implying that its compressor has fewer but thicker windings.

**Figure 30: Direct-DC Refrigerator Prototype**

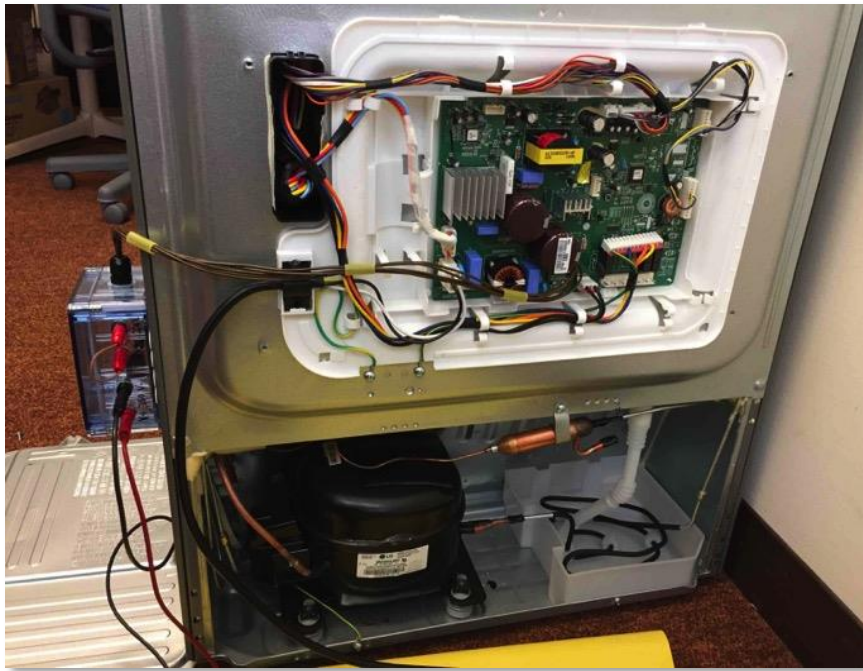

**Prototype for the DC input modification of a refrigerator. The blue box on the left side allows for a 340 V DC input to the inverter board's DC capacitor bus. The compressor is the BMA069LAMV model.**

Source: Daniel Gerber

It is important to note that this refrigerator does not use power factor correction (PFC), and thus has a poor power factor of 0.65. Although inverter-based refrigerators are generally subject to the stringent IEC 61000-3-2 Class D harmonic specifications, these requirements only apply to devices that draw more than 75 W of power (Harmonic Current Emissions 2010; IEC 2014). While the LG refrigerator sometimes draws up to 80 W to operate its compressor, it usually operates below 75 W. The defrost coils draw up to 175 W, but they are a resistive load with a unity power factor. As such, this refrigerator barely slips under the threshold of PFC requirements. Slightly larger refrigerators would require PFC, which lowers the AC efficiency and increases hardware costs.



**Figure 31: LG Refrigerator Inverter Board**

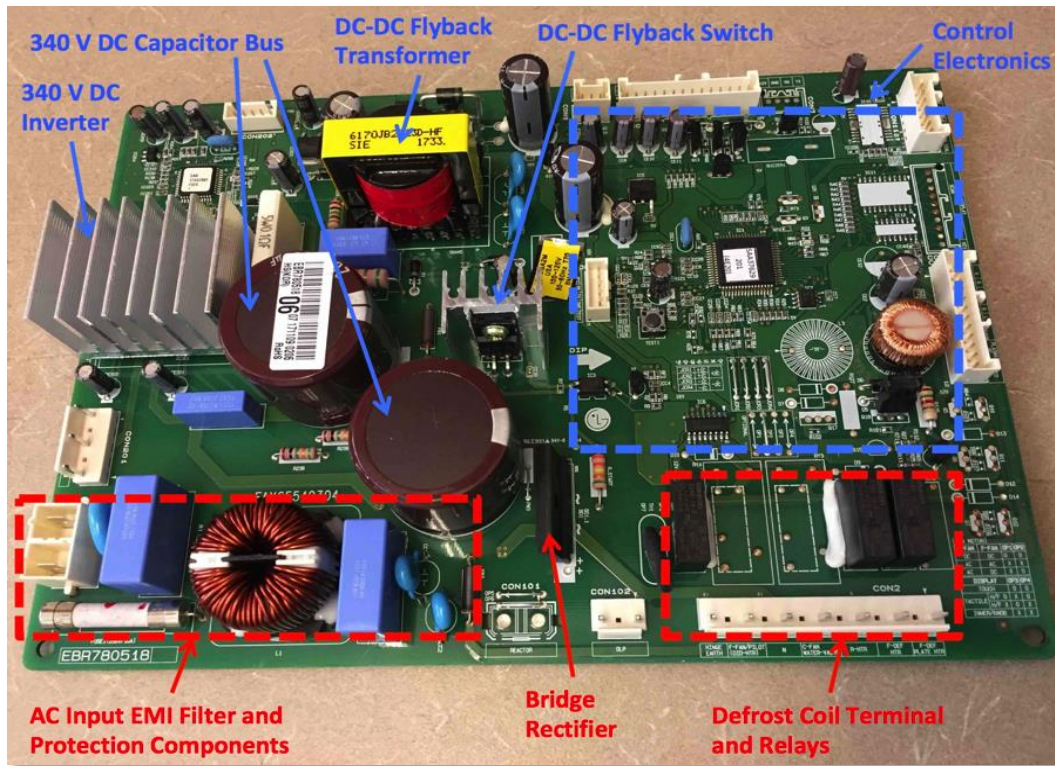

Inverter board for the LG LTNC11121V refrigerator. The inverter is a high-voltage three-phase SIM6822M chip. The board dimensions are 23 x 16 cm.

Source: Daniel Gerber

Finally, DC input allows for a reduction in the size of the DC capacitor bus. Not only are high-voltage high-capacitance electrolytics bulky and expensive, as shown in Figure 31, they are prone to failure and may limit the lifespan of the entire unit (Gu et al. 2009; Chen and Hui 2012). The DC capacitor bus is sized to filter 120-Hz AC power ripple, provide an energy buffer for rapid changes in motor torque, and filter the high-frequency inverter pulse-width modulation (PWM) current injected back onto the line (Salcone and Bond 2009). In general, the line-injected EMI filtering requirements are satisfied by accounting for the other two. The energy buffer requirements are also considerably lower in variable speed compressors that can ramp-up their input power. Overall, the large DC capacitor bus in Figure 31 is required for filtering the 120 Hz AC power ripple, and can be greatly reduced with DC input.

**Figure 32: Danfoss/Secop Inverter Board**



Danfoss/Secop 101N0212 inverter board, for a Danfoss 12/24 V DC refrigerator. The board dimensions are 10 x 6.5 cm. This inverter board can provide up to 113 W when connected to a BD50F compressor at 3,500 RPM and 30°C ambient temperature.

Source: Daniel Gerber

## **6. Task Light**

### **Modifications for Direct Current Input**

LEDs are current controlled, and thus DC systems still require a DC LED driver. Nonetheless, DC LED drivers are more efficient than AC LED drivers, and lighting stands to benefit from DC distribution (Gerber et al. 2018; Fregosi et al. 2015). In addition, the large electrolytic capacitor present in many LED drivers can be significantly downsized. Instead of demonstrating the already well-known advantages of DC LED drivers, this work instead explains two unique ideas for efficient DC lighting design.

Task lights are usually localized to a workspace, and low-voltage DC input from a workspace USB charging station can often be convenient and efficient. Many USB task lights in today's market are powered by a constant voltage 5-V USB-A port and use a ballast resistor for current control, as shown in Figure 33a. The ballast resistor is not only inefficient, but it is also very susceptible to bus voltage swing and does not allow for dimming. Upcoming products will likely leverage USB-PD, shown in Figure 33b, which allows for higher voltage, higher power, and lower cable loss. Higher-end products will also incorporate an LED driver, which allows dimming and can be more efficient than a ballast resistor.

A further improvement is possible, shown in Figure 33c, where the USB charging station becomes the LED driver. Such a solution requires a charging station that supports USB



protocols with a programmable power supply (PPS) capability (USB-PD 3.0 or QC 3.0). With a programmable supply voltage, the lamp needs only to sense the LED current to program the supply voltage accordingly. This method effectively removes the LED driver conversion stage, while still offering all the benefits of an LED driver, such as dimming.

**Figure 33: Direct Direct-Current Task Lamp Modification**

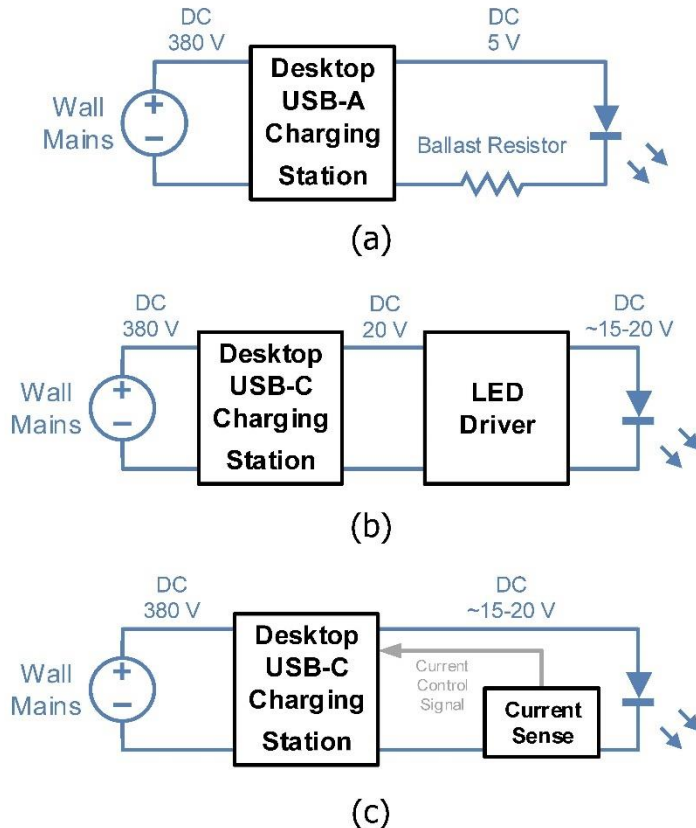

Methods of powering a task lamp with DC input from a desktop charging station. Note that the wall mains could also be 120 V<sub>RMS</sub> AC or 48 V DC. (a) Use a ballast resistor for current control. (b) Connect the LED driver in the lamp to the charging station's output. (c) If the charging station has PPS capability, the charging station can become the constant current LED driver.

Source: Daniel Gerber

### Experimental Prototype and Results

The task light prototype, shown in Figure 34, demonstrated the driverless topology in Figure 33c. This task light was powered from an Anker PowerPort charger with QC 3.0. Since USB-PD 3.0 was not available at the time, QC 3.0 was the only option that had a programmable power supply (PPS) capability. The Anker PowerPort provided up to 12 V to three 1.5 A LEDs (Cree MTG7-001I-XTE00-NW-0GE3). At its brightest operating point, the LEDs drew 1.5 A at 14.3 W (9.815 V). An Arduino microcontroller produced the control signals for brightness and dimming, and the signals were sent via the USB data lines as per the QC protocol (Deconinck, n.d.). Although this proof-of-concept prototype used voltage control, current control is recommended for future products.

**Figure 34: Direct Direct-Current Task Lamp Prototype**



Source: Daniel Gerber

### **Discussion**

As previously shown in Figure 33c, the prototype effectively uses the charging station as an LED driver, thus reducing the number of power conversions. From a hardware perspective, this method is possible in any point-to-point DC topology since every port is current-controlled. The only software requirement is a charging station that supports a DC protocol with PPS capability.

DC protocols such as PoE may have problems combining the LED driver into the PoE switch, since the protocol's tight 48–56 V range is intended only to mitigate voltage drop over the wire. One possibility, shown in Figure 35, would be to design the LED driver with a solid-state bypass switch that can connect the LEDs directly to the PoE line in their brightest state. Dimmed states would disconnect the bypass, and instead use a conventional LED driver to provide constant current at the appropriate voltage to the dimmed LEDs.

**Figure 35: Direct Direct-Current Task Lamp Discussion**

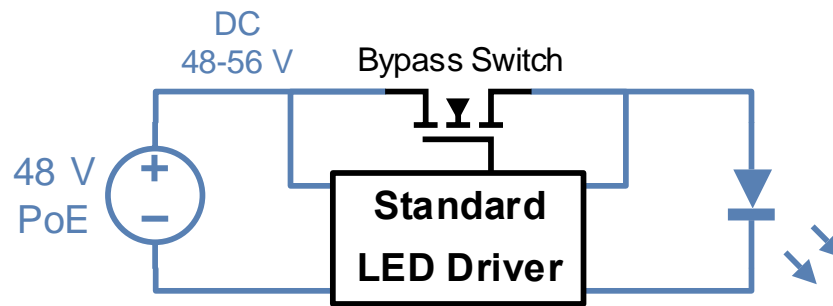

Source: Daniel Gerber

## 7. Zone Lighting

### Modifications for Direct Current Input

Zone lighting systems simultaneously operate many light fixtures and are often found in office and retail buildings. LED bulbs in older buildings have internal LED drivers and are designed to plug into existing incandescent or fluorescent fixtures. In this design, the LED drivers are distributed between the fixtures and may require a separate signaling line for dimming. This system is standard in AC buildings, and many of the experimental 380-V DC test beds also use the distributed LED driver architecture shown in Figure 36a (Boeke and Wendt 2015).

Remote external LED drivers are physically separate from the lamp's LEDs. They have traditionally been popular in commercial or outdoors lighting systems such as streetlights and lit signs (1000bulbs.com 2014). Nonetheless, several companies have started promoting the use of remote LED drivers in lighting systems for newer buildings. First, remote drivers can be very cost-effective since each driver can power multiple fixtures, as shown in Figure 36b. Second, remote drivers can greatly reduce maintenance costs. Since the driver usually limits the lifespan of the entire lamp, a low-cost replaceable driver in an easily accessible location is advantageous. Finally, dimming and control functionality is easier with a remote driver that serves multiple fixtures.

Most commercial remote LED drivers use a parallel design, shown in Figure 36b, which is ideal for applications that require individual fixture control. Another topology, shown in Figure 36c, uses a single line to power the LED fixtures in series. This topology is very uncommon, and the few companies that develop series remote drivers seldom consider its use for zone lighting for buildings.

This work aims to demonstrate that series remote drivers are an excellent design for zone lighting in 380-V DC buildings due to their low overall cost and high efficiency. The cost benefit is a result of using simple low-power hardware to drive many fixtures, as shown in Figure 36c. In addition, the driver's switch stress does not increase with the number of fixtures  $N$ , implying a constant hardware cost.

Series remote drivers also can be significantly more efficient than their parallel counterparts. In general, buck converters are most efficient at a high MOSFET conduction duty cycle, which happens when the output voltage is closely matched to the input. The drivers in Figure 36a and Figure 36b undergo a significant step-down from the mains to the fixture voltage  $V_{\text{FIX}}$ . In

contrast, the series driver in Figure 36c performs a much lighter step-down when several fixtures are attached.

**Figure 36: Direct Direct-Current Zone Light Modification**

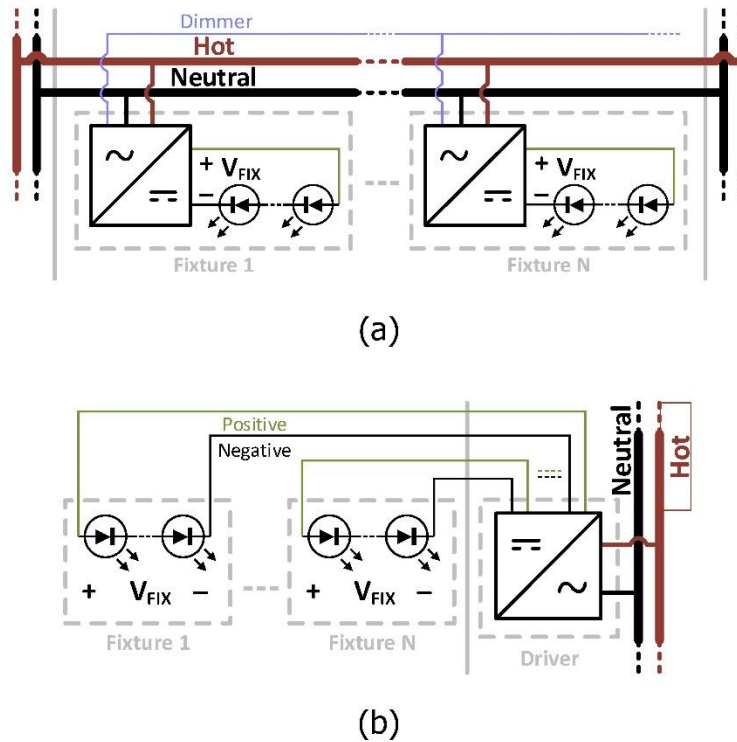

Methods of wiring lighting fixtures. (a) The conventional design with distributed drivers and a dedicated 0–10 V analog dimming line. (b) Most remote driver topologies use an array of parallel current-controlled lines. (c) Series remote driver topology with a buck-based driver. Although depicted with a DC input, series drivers are currently designed for an AC input. In this topology the number of fixtures  $N$  is limited to  $N \cdot V_{FIX} < 380$  V. Nonetheless, a buck-boost LED driver can allow for more fixtures to be attached.

Source: Daniel Gerber

## Experimental Prototype and Results

A 380-V DC series remote driver was prototyped using the topology in Figure 36c. The prototype, shown in Figure 37, used an MP4000 controller, a 600 V IGBT, and a 10-millihenry (mH) inductor. The experimental fixtures were a set of 75-V 18-W 4-ft T8 LED tubes, which come from removing the driver of a PT-T84FP18W. As shown in Figure 38, the driver's efficiency increased with the number of tubes. For reference, the original tube-integrated AC LED driver, shown in Figure 39, operates at 92 percent efficiency and 0.97 power factor.

**Figure 37: Direct Direct-Current Zone Light Prototype**



Source: Daniel Gerber

**Figure 38: Direct Direct-Current Zone Light Prototype Efficiency**

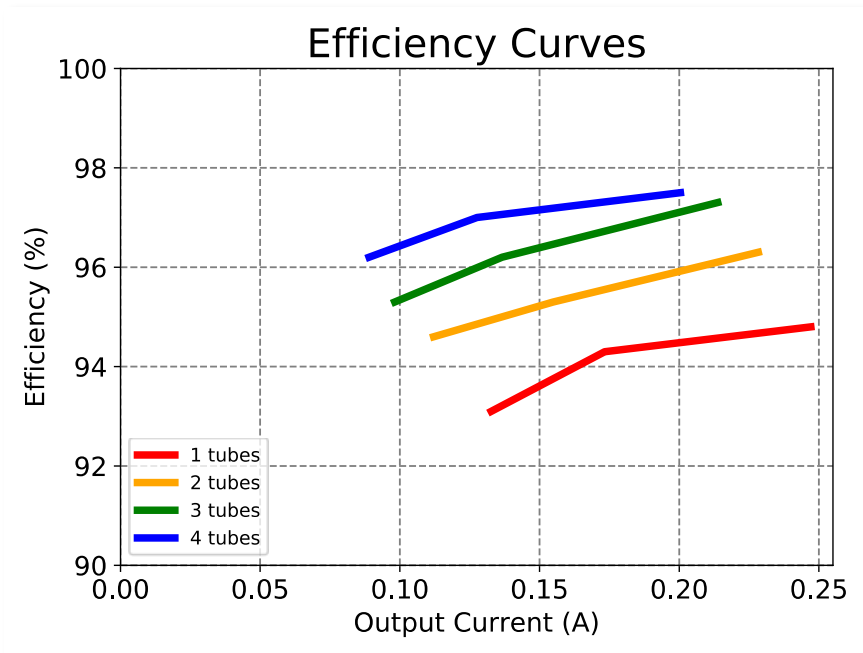

Efficiency curves for the 380 V DC series remote driver with 1–4 LED tubes attached in series. The driver's efficiency increases with the number of attached tubes.

Source: Daniel Gerber

**Figure 39: Original Alternative Current Light-Emitting Diode Driver**



Original AC LED driver packaged in a PT-T84FP18W four-foot LED tube. Board dimensions are 3.5 x 2 cm.

Source: Daniel Gerber

## Discussion

Remote drivers have many advantages over conventional internal drivers, such as cost, maintenance, and control functionality. However, the main drawback is the loss of the plug-and-play simplicity of traditional light bulbs. In addition, remote drivers can have problems with transmission voltage drop when the output LEDs are wired over a long distance. Series remote drivers add the potential to further decrease hardware costs and greatly increase efficiency. Nonetheless, their drawbacks include non-trivial wiring and a loss of the ability to dim individual fixtures in a set. As such, series remote driver architectures are best suited for commercial zone lighting. Overall, further study is required to fully determine the value of series remote drivers in industry applications.

One potential concern with series LED fixtures is that a single LED failure would disable the entire multi-fixture string. This drawback can be overcome by equipping each fixture with a bypass circuit. An example bypass circuit, shown in Figure 40, is based on a design for bypassing individual LEDs (Bollmann and Penick 2013). In this case, the SCR and Zener diode would be sized such that their breakdown voltage is greater than the nominal LED fixture voltage.

**Figure 40: Fixture Bypass Circuit**

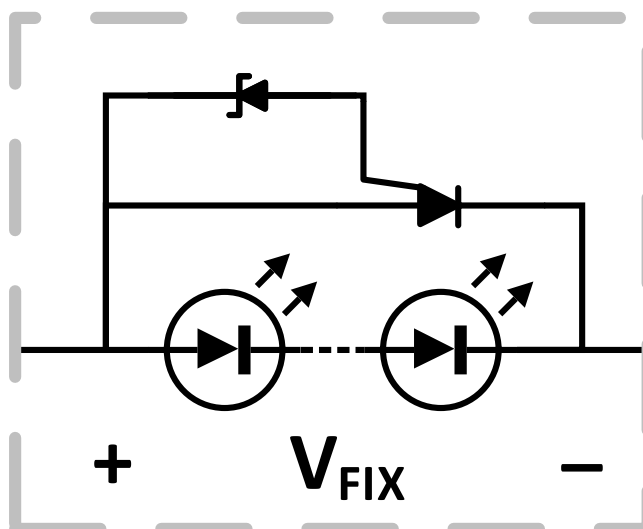

**Bypass circuit for the LED fixtures connected to a series remote driver. This circuit will allow other fixtures to remain powered despite a failure in the series string.**

Source: Daniel Gerber

Another important point of discussion is in the number of fixtures that can be powered by a 380-V series driver. In this experiment, the 380-V buck-based driver only allows five 75-V tubes to be stacked in a series. It is important to note that newer LEDs provide more power with less voltage drop (Keeping 2012; Solly 2007). For example, an 18-W bulb with three modern 6 V 1 A LEDs would only drop 18 V. Twenty-one such bulbs can stack to 380 V, which is enough to cover a moderately sized room. Another possibility is a buck-boost driver (instead of the buck driver in Figure 36c), which would allow a lighting designer the flexibility to install even more fixtures. However, efficiency and safety begin to decline once the series voltage exceeds 380 V.

## 8. Conclusions

Buildings with DC power have taken the recent spotlight in research, but the development of highly efficient DC-ready loads has lagged. This work categorizes the types of loads whose efficiency directly benefits from a DC input. Several types of loads were studied, and some of them are modified or prototyped as direct-DC. These loads include a wall adapter, bath fan, refrigerator, task lamp, and zone lighting rig. The main focus of each design is to leverage DC input to eliminate or improve the conversion stages.

This project obtained new insights during the design, development, and measurement phases. These insights are specific to the categories of electronics, motor loads, and lighting. In electronics, DC input can allow the downsizing or elimination of wall adapters. The efficiency benefits generally favor DC, though the comparisons must be made with careful attention to the distribution voltage and conversion process. In motor loads, the most efficient type of BLDC motor is designed so that its internal DC capacitor bus naturally operates at the DC input voltage. Although there is very little loss across a diode bridge rectifier, a PFC boost rectifier in higher-power products is less efficient than a DC-DC boost converter of the same input and

output voltage. In lighting, task lamps that connect to a DC charging station with programmable power supply capability can use the charging station as the LED driver. Zone lighting can benefit greatly from series remote drivers, but further research must validate their feasibility. In all loads, DC input can allow for a great reduction in the size of DC capacitors, and will also improve power quality. Further study is required to determine the full value of these secondary effects.



# CHAPTER 4:

## Reducing the Energy Use of Safety, Security, and Health Devices

---

### 1. Background and Introduction

An increasing number of energy-using devices is required to provide safety, security, and health functions. These include circuit breakers, AFCI/GFCI outlets and breakers, smoke alarms, carbon monoxide alarms, exit signs, and emergency lighting. This report uses the term Safety, Security, and Health Devices (SSHDs) to describe them. These devices have been largely overlooked with respect to their energy consumption and opportunities for energy savings. Some SSHDs are specifically exempted from energy-efficiency regulations (such as medical devices and security systems using external power supplies). Other SSHDs continuously consume electrical energy even when the device is not providing its primary function. The lack of attention by policymakers is reasonable because the individual components typically draw very little power or they were not especially common (or both). Over time, however, the number of devices required by codes, or made commonplace through evolving medical policies, has increased dramatically and new technologies have appeared that could enable lower energy consumption. These trends suggest that SSHDs deserve renewed attention to determine if substantial energy savings are now feasible.

SSHDs represent one category in the collection of end uses called “miscellaneous electrical loads” or “plug loads.” One approach to understanding and ultimately reducing MELs energy use is to identify groups of devices with common characteristics, such as technologies, responsible authorities, or installers. This approach is likely to reduce costs of gathering data, understanding the industry, and developing energy-saving strategies. In the case of SSHDs, the common characteristic is the strong role played by authorities responsible for life safety, long-term health, and security. Their responsibility and power generally trumps the interests of energy conservation.

### Chapter Organization

This report is organized as follows. It begins by defining SSHDs and explaining why they deserve to be considered as a unique category of devices. A list of important, or “priority,” SSHDs is proposed. The priority devices are explored in terms of their governing regulations, functions, technologies, and energy use. Next, opportunities for reducing SSHD energy use are investigated and estimates of statewide energy savings are computed. Finally, the results are summarized and recommendations are made for further actions to reduce SSHD energy use.

### 2. Safety, Security, and Health Devices in Buildings

SSHDs assure occupant safety and building integrity, both with respect to acute and chronic hazards. Table 7 lists prominent SSHDs and their functions. There are three main administrative categories of SSHDs: (1) those regulated by building codes and standards (referred to as “regulated SSHDs”), (2) those specifically exempted from energy-efficiency

standards (referred to as “exempted SSHDs”), and (3) other. Figure 41 shows how the SSHDs are divided among these administrative categories.

**Table 7: Prominent Safety, Security, and Health Devices**

<b>Device</b>	<b>Purpose</b>
Ground-Fault Circuit Interrupters (GFCI)	Protects people from electric shock, especially in presence of standing water
Arc-Fault Circuit Interrupters (AFCI)	Protects building from fires started by arcing wires
Smoke alarms	Warns occupants of fire and smoke
Carbon monoxide (CO) alarms	Warns occupants of dangerous CO levels
Security/Alarms	Detects and signals building intrusion (“burglar alarm”)
Illuminated address signs	Ensures readability of street address at night
Garage door openers with battery backup	Ensures that people can evacuate during a power outage
Home oxygen concentrators	Concentrates oxygen from ambient air for use by people with low oxygen levels in their blood
Continuous positive airway pressure (CPAP) ventilators	Treats sleep apnea by providing continuous airway pressure during sleep
Exit signs	Illuminated displays to assist occupants in leaving a building during an emergency
Emergency lighting	Illumination to assist occupants in evacuation of a building when grid power has been interrupted
Device	Purpose
Mechanical ventilation fans	Ensures supply of fresh air and removal of moisture, pollutants, and odors
Radon mitigation fans	Controls indoor radon gas levels
Sump pumps	Removes water that has accumulated in a water-collecting sump, commonly found in basements
Sewage (ejector) pumps	Ejects and pumps sewage when plumbing fixtures are below grade of sewer line
Flood/leak alarms	Detects and signals standing water
Local Network Equipment	Provides network connectivity using devices such as modems, switches, routers, and optical network terminals

Source: LBNL

**Figure 41: Safety, Security, and Health Devices by Administrative Category**

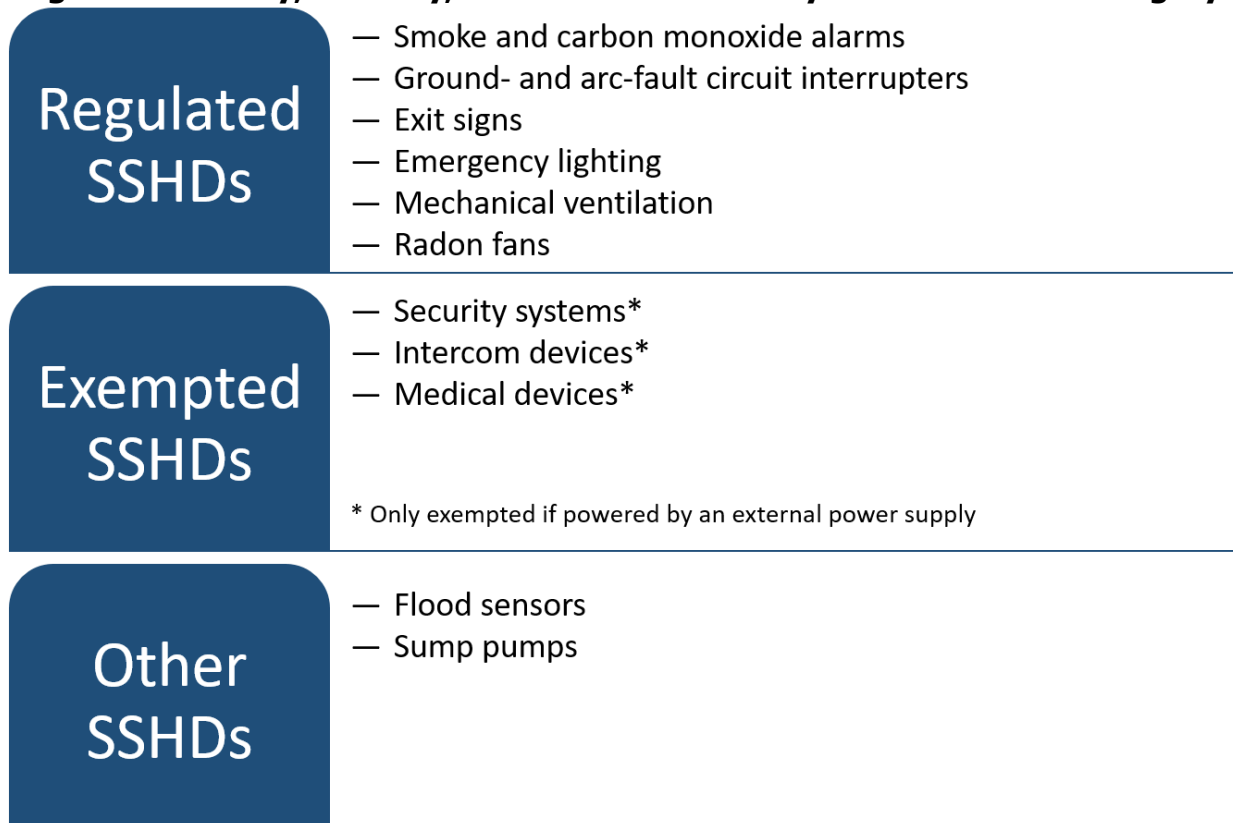

Source: LBNL

The list of SSHDs will grow. Recent California legislation (September 2018) mandates installation of back-up power with all new automatic garage door openers (Dodd 2018). This will enable garage doors to be opened in the event of a power failure (such as those caused by the Tubbs fire in 2017 and the Camp fire in 2018). However, maintaining the battery charge also adds several watts to the home's electricity use. Surveillance systems—wired and wireless—are emerging as a distinct product separate from other types of security systems. These units can easily draw 10 W (90 kWh/year). Some California communities require homes to have illuminated street address numbers. These lights can draw as much as 8 W (70 kWh/year). Most operate continuously because they lack switches or photo-controls.

Other devices are sure to enter this category. For example, a few advanced buildings have systems to counteract seismic forces or wind loads (Saaed et al. 2015). The seismic technologies are typically divided into passive, active, and hybrid approaches. Active systems—which are still rare—appear to require continuous power. Home medical equipment will become both more extensive and diverse in response to the rising costs of hospitalization and increasingly sophisticated automated health-delivery equipment.

### **Safety, Security, and Health Devices and Energy-Efficiency Regulations**

Most of the SSHDs identified in this report are not covered under state or national energy-efficiency standards. This can be partially attributed to enacted legislation from Section 325(u)(3)(E) of the Energy Policy and Conservation Act, which concerns the “non-application of no-load mode energy efficiency standards to external power supplies for certain security or life-safety alarms or surveillance systems.” Under the provisions of section 325(u)(3)(E)(i)(I),

smoke and carbon monoxide alarms, as well as security systems, fall under the definition of “security or life-safety alarm or surveillance system.” While smoke and carbon monoxide alarms are rarely powered by an external power supply, security systems typically are. Similarly, the 2016 California Appliance Efficiency Regulations (Baez et al. 2016) do not cover external power supplies that require Federal Food and Drug Administration (FDA) listing and approval as a medical device. Additionally, on January 23, 2017, the Power and Security Systems (PASS) Act—a bill which, in part, extends the currently expired energy conservation standards exemption for external power supplies for security or life-safety systems until July 1, 2023—passed the U.S. House of Representatives without amendment (U. S. Congress 2017) and was ultimately signed into law by the President on November 2, 2017.

California’s Title 20 requires that all self-contained lighting controls—which are included in emergency lighting systems—manufactured on or after February 1, 2013, and having indicator lights that are integral to the system must use indicator lights that consume no more than 1 W per light. Additional regulations applying to the standby-power consumption of emergency lighting systems were not found.

However, DOE does regulate the energy consumption of illuminated exit signs manufactured on or after January 1, 2006, which are currently required to have an input power demand of 5 W or less per face (10 CFR 431.206). Exception 2 to Section 140.8 of the 2016 California Building Energy Efficiency Standards for Residential and Nonresidential Buildings mandates that exit signs meet the requirements of appliance-efficiency regulations.

### **Existing Literature Pertaining to Safety, Security, and Health Devices Energy Use**

Existing literature on the power consumption of SSHDs is sparse and highly dispersed. The absence of literature is due partly to the fact that most devices draw very little power (hence unimportant), are difficult to measure, or simply escape notice. Sometimes manufacturers’ specification sheets list power consumption for specific products, but these may be peak or nameplate values. A few reports and white papers have been published that provide some insight into the power consumption of these devices. Table 8 summarizes the results of the literature search.

**Table 8: Reported Power Consumption of Some Safety, Security, and Health Devices**

<b>Source</b>	<b>SSHD</b>	<b>Results</b>
Permanent Electrical Loads in New Homes (Meier and Aillot 2016)	Various, including smoke alarms, AFCIs, and security systems	This paper covers, in some detail, many of the SSHDs discussed here. Of their measurements, most of the SSHDs consumed 4 W or less (Figure 3).
Eaton White Paper AP08324002E (effective July 2010) (Eaton 2010)	Circuit breakers	Results reported for numerous types and ampacities of molded-case circuit breakers (MCCBs). MCCBs rated at 20–40 amps use between 0 and 8 W (Table 27).
Natural Resources Defense Council (NRDC) Issue Paper 15-03-A (May 2015) (Delforge, Schmidt, and Schmidt 2015)	GFCI outlets and security systems	From a 10-home sample, GFCI outlets consumed an average of 1 W while security systems consumed an average of 8.2 W (Table 3).
LG&E Watt Finders Guide (LG&E 2018)	Smoke alarm	2 W
Low-Power Mode Energy Consumption in California Homes (CEC-500-2008-035, September 2008) (California Energy Commission 2008)	GFCI outlets and smoke alarms	GFCI outlets consume an average of 0.7 W and smoke alarms consume an average of 0.6 W.

Source: LBNL

The findings provided in Table 8 come mainly from outdated sources. There are also discrepancies among the reports. Nevertheless, the findings from these sources indicate that SSHDs have a continuous, non-trivial power draw. The remainder of the report draws upon additional sources for specific aspects and cites them as appropriate.

### **Priority Safety, Security, and Health Devices**

Based on the literature search and preliminary calculations, 10 “priority” SSHDs were selected for further investigation. This group consists of both high numbers of users and high populations. Most of the devices are in residential buildings, but two ubiquitous devices—exit signs and emergency lighting—are only in commercial buildings. Table 9 lists the priority SSHDs, the principal building sector in which they are installed, and the regulations that cover them.

**Table 9: Priority Devices Selected for Further Investigation in This Report**

SSHD	Sector	Required by Building Code	Regulated by Energy Code	Exempted from Energy Code
GFCIs	Residential	✓		
AFCIs	Residential	✓		
Smoke alarms	Residential	✓		
CO alarms	Residential	✓		
Security/Alarms	Residential			✓
Oxygen concentrators	Residential			✓
CPAP ventilators	Residential			✓
Mechanical ventilation	Residential	✓		
Exit signs	Commercial	✓	✓	
Emergency lighting	Commercial	✓		

Source: LBNL

### 3. Investigations of Priority Safety, Security, and Health Devices

#### Introduction

SSHDs provide a wide range of services, so it is not surprising that they rely on diverse and often esoteric technologies to accomplish them. The details of these technologies are poorly documented in the open literature and are sometimes proprietary. Many SSHDs are hard wired into a building’s electrical infrastructure and require special equipment to safely meter their electricity consumption and behavior—a simple Kill A Watt® meter available from many public libraries will not suffice. As a result, the only means of truly understanding their energy consumption and the opportunities for energy savings involves detailed physical investigation. These investigations involve direct inspection, measurement, and disassembly. This work also includes careful review of relevant codes, technical standards, and manufacturers’ component specifications. For each of the priority devices, the codes, market situation, energy use, and other relevant issues were reviewed. Teardowns of selected SSHDs were performed and opportunities for improvements based on those investigations are discussed.

The technical specifications and performance of many SSHDs are covered by health and safety codes and standards, such those issued by the National Fire Prevention Association (NFPA), Underwriters Labs (UL), and the American Society of Heating, Refrigeration and Air-Conditioning Engineers (ASHRAE). These are typically referenced in state and local building codes. Table 10 summarizes the key health and safety codes applicable to the life-safety devices.

**Table 10: Residential Health and Safety Devices Required by Building Standards**

<b>Device</b>	<b>Code/Standard</b>
Ground-Fault Circuit Interrupter (GFCI)	NFPA 70 UL 943
Arc-Fault Circuit Interrupter (AFCI)	NFPA 70 UL 1699
Smoke alarm	NFPA 101 UL 217
Carbon monoxide (CO) alarm	NFPA 720 UL 2034
Continuous mechanical ventilation	ASHRAE 62.2
Emergency lighting	UL 924
Exit signs	UL 924

Source: LBNL

These codes do not explicitly address the devices' energy consumption (although their specifications can affect it). For example, a minimum rate of air exchange can only be achieved by a ventilation system causing air movement that requires a minimum power.

### **Ground-Fault and Arc-Fault Circuit Interrupters**

A GFCI is a device that detects an imbalance between the current in the hot and neutral lines of a circuit and disconnects the circuit before any harm can be done. The National Electric Code (NEC) first required that residential outdoor receptacles be protected by GFCIs beginning in 1975 (Berman 2009). Since then numerous other receptacles in the home have been added, including those in bathrooms, kitchens, garages, basements, and crawl spaces. The GFCI can be integrated into both breakers and outlets, but because outlets are cheaper (and more user-friendly), builders and contractors tend to use them almost exclusively (Figure 42). The current stock of residential GFCIs were calculated by estimating the number of GFCIs installed in new construction for each year since 1980, using the code requirement at the time and the number of new housing units. It is estimated that there are currently over 23 million GFCIs in California homes and that the average new home has eight (although this can easily be as many as 15). A contractor can reduce the number of GFCIs by daisy-chaining nearby outlets or using a breaker. The estimated stock of GFCIs is conservative because it includes only single-family homes and excludes GFCIs installed during renovations. In addition, commercial buildings are not included. The actual number could be over 50 million. This information was used to estimate statewide energy use in Table 16, in Chapter 4.

**Figure 42: Ground-Fault and Arc-Fault Circuit Interrupters**



Source: LBNL

While the purpose of a GFCI is to prevent electrical shock, the primary purpose of an AFCI is to prevent fires. It does this by continually analyzing the circuit waveform for characteristics known to be associated with wire arcing. The NEC first required that bedroom outlet circuits be protected by AFCIs in 2002 and extended the requirement to all outlets in new homes beginning in 2008 (Tuite 2007). Because AFCIs protect the wire, not the device or person, they are almost exclusively used in breakers, although an outlet AFCI will protect appliance cords and extension cords plugged into it. Using the same method as for GFCIs, it is estimated that about 4.7 million AFCIs are in California homes and that the average new house has four AFCIs.

According to Section 210.8 of the 2016 California Electric Code and the 2014 and 2017 National Electric Codes (NFPA 70), circuits in various locations in dwelling and non-dwelling units (such as bathrooms, kitchens, crawl spaces, and garages), as well as boat hoists, kitchen dishwasher branch circuits, and crawl-space lighting outlets require protections by GFCIs under certain conditions. Similarly, for AFCIs, Section 210.12 of the 2016 California Electric Code and the 2014 and 2017 National Electric Codes (NFPA 70) require circuits in various locations in dwelling units (such as bathrooms, kitchens, family rooms, dining rooms, and



bedrooms), as well as dormitory units, guest rooms and guest suites, and branch-circuit extensions or modifications to dwelling and dormitory units to be protected by AFCIs under certain conditions.

### **Smoke and Carbon Monoxide Alarms**

Residential smoke alarms detect smoke and emit an audible alarm when smoke is detected (Figure 43). They employ two types of sensing technologies: ionization, which uses a radioisotope to ionize air molecules, and photoelectric, which operates on a light-scattering principle. The first modern ionization smoke alarm became available for use in 1963, but its widespread use in residential homes did not begin until the early 1970s (U. S. Nuclear Regulatory Commission 2017). Smoke alarms were first required in homes starting in 1976 and the requirements were extended to all bedrooms starting in 1988 (Public/Private Fire Safety Council 2006). Using the same method for estimating stock as for GFCIs, it is estimated that 19.5 million hardwired smoke alarms are in California homes and that the average new house has five smoke alarms.

**Figure 43: Smoke and Carbon Monoxide Alarm**



Source: LBNL

According to Section 907.2 of the 2016 California Fire Code and 2015 International Fire Code, smoke alarms in new construction shall receive their primary power from the building wiring, shall have a battery backup, and shall be interconnected with other smoke alarms in locations where more than one smoke alarm is required. Furthermore, sections 29.5 and 29.6 of the 2016 National Fire Code (NFPA 72) require that alarms and heat alarms be interconnected, and also requires that household fire alarm systems have two independent power sources consisting of a primary source (such as mains power) and a secondary source (such as a battery). Finally, Section 9.6 of the 2018 Life Safety Code (NFPA 101) references NFPA 72 for the power requirements of smoke alarms, other than those permitted by other sections of NFPA 101 to be battery-operated.

Carbon monoxide (CO) alarms detect the presence of CO gas, usually due to malfunctioning gas-fired equipment such as furnaces and water heaters. They are a much more recent addition to homes than smoke alarms, and were required by AB 183 starting in 2011 (State of California 2010). Gundel et al. (1998) indicates that three types of CO sensor can be used: biomimetic, metal oxide sensor (MOS), and electrochemical cell. Section 4.5 of the 2015 National Standard for the Installation of Carbon Monoxide (CO) Detection and Warning Equipment (NFPA 720) requires that unless the CO alarm is installed with an uninterruptible power supply (central battery backup), it must have at least two independent and reliable power supplies. The primary power supply must be a branch circuit supplying no other loads. Additionally, Sections 915.4 and 915.5 of the 2016 California Fire Code and 2015 International Fire Code require that carbon monoxide alarms receive their primary power from the building wiring (with a secondary battery backup), and alarms must be interconnected in locations where multiple alarms are required. Using the same method as for GFCIs, it is estimated that 0.8 million hardwired CO alarms are in California homes and that the average new house has two alarms.

Both smoke and CO alarms are required to be hard-wired in new construction projects in California, as well as in other states that have adopted these regulations.

## Security and Alarms

Home security systems (Figure 44) detect a variety of building conditions and intrusions and then signal an audible or electronic alarm when an intrusion occurs.

**Figure 44: A Home Security System**



Source: LBNL

These systems consist of many components, which are linked either through wires or wirelessly. Components include power supplies, battery chargers, controls, keypads, communication hardware, active and passive sensors, and cameras (and illumination for them). Common sensors include motion detectors, occupancy sensors, and door and window sensors. Alarm controls are typically powered by one or two 24 VAC transformers that keep the backup battery charged. Measured energy use of security systems is mostly anecdotal from single devices or small samples. This is partly due to the difficulty of measuring a product

that has to be itself secure. For this analysis it is assumed that security systems used 8.2 W (Delforge et al. 2015) and that 20 percent of single-family homes, or 1.8 million, had one (Security System News 2009).

## Oxygen Concentrators

About 1.8 million Californians have chronic obstructive pulmonary diseases (COPD) such as bronchitis or emphysema (U.S. Centers for Disease Control and Prevention n.d.). Many of these people require home oxygen therapy to help them breathe, mitigate the symptoms of their disease, or slow disease progression. The oxygen required is typically delivered by an oxygen concentrator (Figure 45), which removes nitrogen from the air using an air compressor to drive a pressure swing adsorption (PSA) cycle. The PSA cycle is an energy-intensive process, but its total cost is lower than other oxygen systems such as high-pressure cylinders or cryogenic liquid, which have mostly been replaced for home use. Oxygen concentrators are available as both stationary, mains-powered and portable, battery-powered devices. They can deliver 1 to 10 liters per minute of oxygen and draw 70–450 W, typically continuously, corresponding to 600–4,000 kWh/year. Portable units typically draw less power than stationary units and can further reduce power use by delivering oxygen using a “pulse” when the user inhales. Rated power use of stationary units appears to be well correlated with rated capacity, averaging 70 W/l/minute (Table 11). What is unknown is how reducing oxygen flow affects power use (how proportional the power use is). It appears that, at best, power is weakly proportional, so assuming rated power for all operating hours may be reasonable. The large range in energy use indicates that there may be energy-saving opportunities such as using portable technology in stationary devices and controlling the oxygen delivery rate more intelligently.

**Figure 45: A Stationary Oxygen Concentrator**



Source: LBNL

About 18.5 percent of Medicare patients with COPD used sustained oxygen therapy in 2010 (Nishi et al. 2015). Assuming the same rate for the general population and applying it to the 1.8 million California COPD patients resulted in an estimate of 320,000 oxygen concentrators in California.

**Table 11: Power Use of Stationary Oxygen Concentrators**

Concentrator	Capacity (l/min)	Power (W)	Normalized Power (W/l/min)
Philips Everflow 1020001	5	350	70
Philips Millennium 605	5	450	90
AirSep NewLife Elite 5	5	350	70
AIRSEP® VISIONAIRE™	3	175	58
AIRSEP® NEWLIFE® INTENSITY	10	590	59

Source: LBNL

### Continuous Positive Airway Pressure Ventilators

About 22 million Americans suffer from sleep apnea—a temporary cessation of breathing while sleeping. Continuous positive airway pressure (CPAP) ventilators (Figure 46) are used to treat sleep apnea by providing continuous airway pressure during sleep. In addition to the air pump, CPAP machines have heaters and humidifiers to condition the ambient air when it is cold or dry. Heaters and humidifiers add significantly to CPAP energy use and may be responsible for the majority of it. New CPAPs have data collection and upload features (through WiFi or cellular networks) that enable health providers and patients to monitor their usage. The data features and displays also contribute to continuous energy use.

**Figure 46: Continuous Positive Airway Pressure Ventilator**



Source: LBNL

CPAP machines draw 10–100 W (depending on the selected pressure, temperature, and humidity) but are used at most 8 hours per day. Therefore, a CPAP’s annual electricity use is

30–300 kWh/year. It is estimated that 80 percent of the cases of moderate and severe obstructive sleep apnea go undiagnosed and that 50 percent of the people diagnosed with disordered breathing actually use the recommended CPAP device. By combining these factors, it is estimated that there are approximately 260,000 CPAP ventilators in use in California.

## Exit Signs

Although exit signs (Figure 47) have been ubiquitous in non-residential buildings since the 1940s, their characteristics have changed significantly. Modern exit signs are either LED or electroluminescent (which can use as little as 0.25 W) and have integrated battery backup. According to Section 1013.6 of the 2016 California Fire Code and 2015 International Fire Code, exit signs shall be illuminated at all times (requiring continuous primary power), and they must be connected to an emergency power system in the event of primary power loss. Based on an audit of a 60,000-square-foot office building, it is estimated that there are 0.73 exit signs per thousand square feet, which results in an estimate of 6 million exit signs in California. This information is used to estimate statewide energy use in Table 16, in Chapter 4.

**Figure 47: Exit Sign**



Source: LBNL

## Emergency Lighting

Emergency lighting (Figure 48) is used to illuminate egress pathways in the case of power failure. They typically consist of either stand-alone wall mounted units or battery-backed ballasts in existing fixtures. Requirements for emergency lighting can be found in national building codes as far back as the 1920s (Wilson 2012).

**Figure 48: Emergency Lighting**



Source: LBNL

According to Section 1008.3 of the 2016 California Building Code, an emergency electrical system shall automatically illuminate specific areas of buildings, rooms, and spaces for a duration of at least 90 minutes in the event of primary power failure in buildings, rooms, and spaces that require at least two means of egress. Furthermore, this emergency power system shall consist of storage batteries or an on-site generator. Section 7.9 of the 2018 Life Safety Code also specifies various locations for which emergency lighting for means of egress must be provided, along with specific performance requirements (such as illumination levels and duration). Based on the same audit as for exit signs it is estimated that there are 0.86 emergency lights per 1,000 square feet, which results in an estimate of 7 million emergency lights in California.

## **Mechanical Ventilation**

Beginning in 2009, the California Building Energy Standards (Title 24, Part 6) adopted requirements for mechanical ventilation based on ASHRAE 62.2 (Ventilation and Acceptable Indoor Air Quality in Low-Rise Residential Buildings). The ventilation can be provided in a number of ways, including balanced (heat recovery ventilators and energy recovery ventilators), supply only (integrated into the HVAC system), and exhaust only (a dedicated exhaust fan, typically in the bathroom). Home builders typically select the exhaust-only method because it is the cheapest to purchase and install. Exhaust-only ventilation is intended to operate continuously, thereby increasing electricity consumption. However, field studies have shown that up to 75 percent of systems are disabled by the occupants (Walker et al. 2019), presumably to avoid drafts, thermal discomfort and noise, and to save energy. Mechanical ventilation was first required in the 2009 code, so it is assumed that it would begin to be used in 2011 new homes, resulting in 400,000 systems. This number was reduced to 25 percent to reflect actual usage rates.

## **Detailed Analysis of Residential Life-Safety Safety, Security, and Health Devices**

Four categories of the priority SSHDs were subjected to detailed measurement and analysis: GFCIs, AFCIs, smoke alarms, and CO alarms. All of them are life-safety devices that have been required in new homes for many years (often in many locations). In new construction they are nearly always hardwired (that is, installed as a permanent part of the home's electrical infrastructure) and thus difficult to measure. These SSHDs are fully mature, commodity items (though IoT technology may change that in the future).

As a first step, the market was surveyed by reviewing the types of devices available and the features that might influence energy usage, such as basic configuration, manufacturer, and options. Table 12 shows the range of manufacturers and options that are readily available for each category of device. Two to five major manufacturers typically offer products and are readily available, although as many as 10 manufacturers were identified in each category.

**Table 12: Market Survey of Residential Life-Safety Devices**

<b>Device Category</b>	<b>Number of Manufacturers</b>	<b>Self Test or Sensor Type</b>	<b>Indicator Light or Network</b>
GFCI outlet	4	Yes/No	Yes/No
GFCI breaker	4		Yes/No
AFCI outlet	2	Yes/No	Yes/No
AFCI breaker	4		Yes/No
AFCI/GFCI outlet	3	Yes/No	Yes/No
AFCI/GFCI breaker	4		Yes/No
Smoke alarm	5	Ionization, Photoelectric, Dual	Wire, RF, WiFi
CO alarm	4	Biomimetic, Metal oxide semiconductor (MOS), Electrochemical	Wire, RF, WiFi
Smoke/CO alarm	4	Photoelectric/electrochemical, Split-spectrum/electrochemical, Proprietary	Wire, RF, WiFi

Source: LBNL

Options vary depending on the category of device. Both AFCIs and GFCIs can have various combinations of LEDs to indicate the state of operation, while currently only GFCI outlets are required to have a self-test capability. Both smoke and CO alarms can use different types of sensors. For smoke alarms the primary sensors are ionization and photoelectric or a combination of the two. Only CO alarms with electrochemical sensors were found to be available.

All alarms installed in new homes are required to be networked and most use a simple 9-V hard-wired network, but there are also wireless devices available that use either proprietary RF or WiFi. In addition to these basic options, some CO alarms can have a digital display of CO levels, and some alarms can have voice annunciators instead of or in addition to a traditional alarm.

The goal of the testing was to identify the effects of technology options on energy use and to then infer available efficiency improvements. Given the broad range of devices and options, a sparse test matrix of devices was developed. For each category of device, a base configuration of product was selected and as many manufacturers as possible with this configuration were identified. Then one manufacturer was selected and a number of other configurations were identified to see what effect they might have on energy use. Table 13 shows an example matrix for smoke alarms. Initially 35 products were identified for purchase. However, during the purchase process, 10 were not available and had to be replaced with equivalent devices. Replacements were available for all but one product. Table 14 shows a summary of the final set of 34 products. (A full list, along with the manufacturer, cost, and options, is provided in Appendix A.)

**Table 13: Smoke Alarm Test Matrix**

Manufacturer	Photoelectric Sensor (Base)	Ionization Sensor	Dual Sensor	Wired Inter-connection (Base)	RF Inter-connection
A1 (Base)	✓	✓	✓	✓	✓
A2	✓			✓	
A3	✓			✓	
A4	✓			✓	

Source: LBNL

**Table 14: Summary of Residential Life-Safety SSHDs Tested**

Device Category	# Devices	# Manufacturers	Base Configuration	Additional Options
GFCI outlet	5	5	LED, Self-test	—
GFCI breaker	3	3	—	—
AFCI outlet	2	2	LED	—
AFCI breaker	3	3	LED	—
AFCI/GFCI outlet	2	2	LED, Self-test	—
AFCI/GFCI breaker	2	2	LED	—
Smoke alarm	7	4	Ionization, LED, Wired	Photoelectric, dual, RF
CO alarm	4	3	Electrochemical, LED, Wired	Display, no interconnect
Smoke/CO alarm	6	4	Photoelectric/ electrochemical, LED, Wired	Voice, RF, WiFi

Source: LBNL

**Measurement Procedure**

Because all of the residential life-safety SSHDs were hard wired it was necessary to construct a measurement fixture for each category of device to safely measure their power consumption. The GFCI and AFCI outlets and the alarms were mounted to a single-gang junction box wired with a short appliance cord with a NEMA 5-15 plug. The breakers were each mounted in one of three small load centers (one for each type of breaker) that were wired similarly to the duplex box. The junction box test fixture and one of the load center test fixtures are shown in Figure 49.



**Figure 49: Test Fixtures**

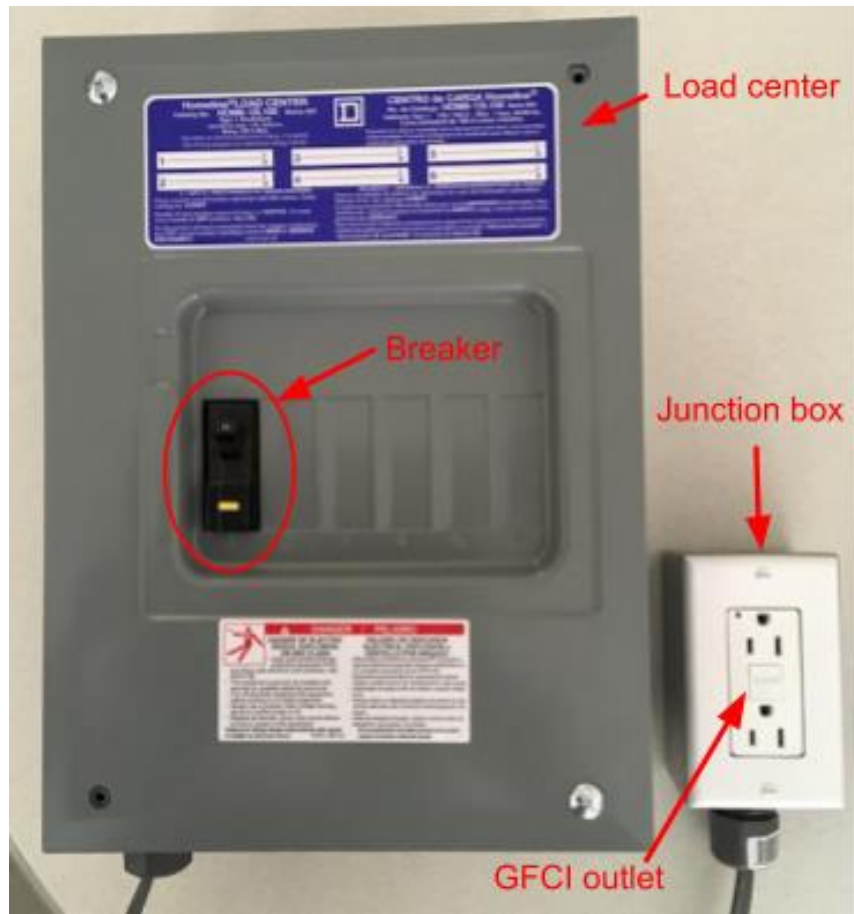

**Junction box on the right and one of the load centers on the left.**

Source: LBNL

Power was measured using a Chroma 66202 Digital Power Meter that can measure power to 0.1 MW resolution with an accuracy of 0.1 percent of reading  $\pm 0.1$  percent of range. The devices under test were connected to the power meter using the Chroma A662003 measurement test fixture, which is used for measuring plug loads (Figure 50). Data were recorded on a 1-second basis using the Chroma Soft Panel software running on an attached PC. Data points recorded included voltage, current (amps), average power (watts), apparent power factor, total harmonic distortion of the current (THDi), and total harmonic distortion of the voltage (THDv).

**Figure 50: Power Measurement Test Configuration**



A smoke alarm is mounted to the junction box test fixture, which is connected to the Chroma 66202 digital power meter using the A662003 measurement test fixture.

Source: LBNL

To accurately and repeatedly measure the energy use of the residential life-safety SSHDs a test method based on IEC 62301 was developed (see Appendix B-2). Each device was measured for 10 minutes continuously; then data gathered during the last 5 minutes were used to calculate the results (with the first 5 minutes acting as a warm-up period). Since the controls of GFCI and AFCI outlets are on the line side, they were measured in both set and tripped mode (breakers have the controls on the load side and thus have no energy use in tripped mode). The alarms equipped with wireless networking were measured in both connected and non-connected modes. For all devices the status of all lights and displays were noted and a picture of the voltage and current waveforms was recorded (an example is shown in Figure 51).

**Figure 51: Example Current and Voltage Waveforms from a Smoke Alarm**

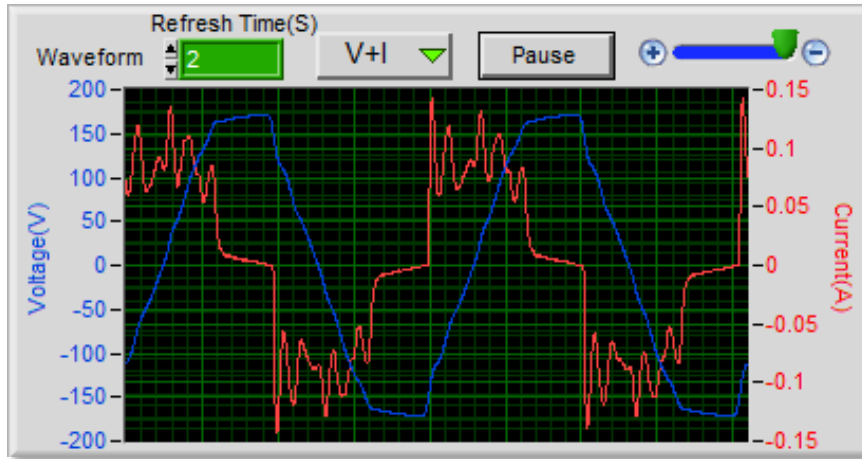

Source: LBNL

Other calculations were performed in addition to the recorded data. To verify that the power mode was stable, a linear regression of the power with respect to time was performed with the required slope to be less than 1 percent. Power use of the device was calculated as the mean of the 5-minute power measurements. The measured power factor is the apparent power factor ( $pf_{app}$ ), the ratio of the real power to apparent power, which is made up of two components: the distortion power factor ( $pf_{dist}$ ) and the displacement power factor ( $pf_{disp}$ ). The distortion power factor was calculated from measured THDi using equation 4 and the displacement power factor was calculated using equation 5.

$$\frac{1}{\left(1 + \left(\frac{THDi}{100}\right)^2\right)^{0.5}} \frac{1}{\left(1 + \left(\frac{THDi}{100}\right)^2\right)^{0.5}} \frac{1}{\left(1 + \left(\frac{THDi}{100}\right)^2\right)^{0.5}} pf_{dist} = \frac{1}{\sqrt{1 + \left(\frac{THDi}{100}\right)^2}} \quad (\text{Eq. 4})$$

$$pf_{disp} \frac{pf_{app}}{pf_{dist}} \frac{pf_{app}}{pf_{dist}} \frac{pf_{app}}{pf_{dist}} = \frac{pf_{app}}{pf_{dist}} \quad (\text{Eq. 5})$$

## Findings

Power use for all residential life-safety SSHDs was very consistent and stable (for example see Figure 51). Linear regression of the power with respect to time resulted in slopes averaging— $2.3 \times 10^{-4}$  W/s (IEC62301 requires a slope of less than  $10^{-2}$ ), and no device had a slope greater than  $-6.6 \times 10^{-4}$  W/s. A summary of the results of the testing is summarized in Table 15 (A full set of results is provided in Appendix B. For each device category Table 15 lists the device power (average, minimum, and maximum within the category) and power factor (average, minimum, and maximum within the category). Note that the average power for each category is quite similar, averaging  $0.72 \pm 0.15$  W (20 percent). But the power use of individual devices within each category can differ by as much as a factor of five.

Another observation is that multiple-function devices such as GFCI/AFCI outlets and smoke/CO alarms do not typically use more energy than single-function devices; in fact, they often use less (Figure 52).

**Table 15: Summary of Test Results**

Device Category	N	Average Power (W)	Min. Power (W)	Max. Power (W)	Avg Power Factor	Min. Power Factor	Max. Power Factor
GFCI breaker	3	0.60	0.56	0.65	0.84	0.53	0.99
AFCI breaker	3	0.73	0.65	0.84	0.65	0.12	0.99
GFCI/AFCI breaker	2	0.79	0.25	1.34	0.27	0.20	0.35
GFCI outlet	5	0.81	0.53	1.01	0.92	0.72	1.00
AFCI outlet	2	0.80	0.79	0.81	0.45	0.12	0.78
GFCI/AFCI outlet	2	0.69	0.36	1.01	0.71	0.61	0.81
Smoke alarm	7	0.89	0.31	1.19	0.25	0.11	0.71
CO alarm	4	0.58	0.40	0.79	0.25	0.08	0.41
Smoke/CO alarm	6	0.62	0.31	1.23	0.29	0.09	0.51

Source: LBNL

**Figure 52: Comparison of Ground Fault Circuit Interrupter Outlet Power**

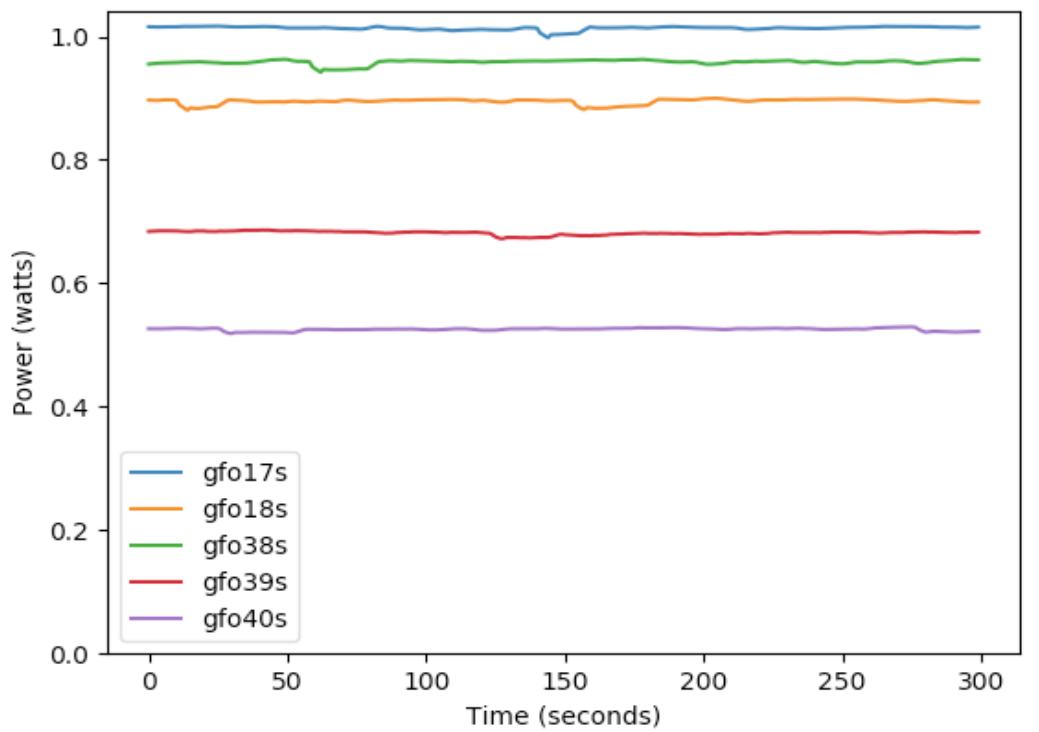

Source: LBNL

The variation in power factors is also of interest as it varies immensely, ranging from 0.08 to 1.00. It was expected that a low-power factor might indicate low quality and possibly higher

power use; instead, the results showed that power factor was not at all correlated with power use (Figure 53). Even among the lowest power factor devices (<0.25) power ranged from 0.4–1.4 W.

**Figure 53: Plot of Power Factor with Respect to Power for All Tested Safety, Security, and Health Devices**

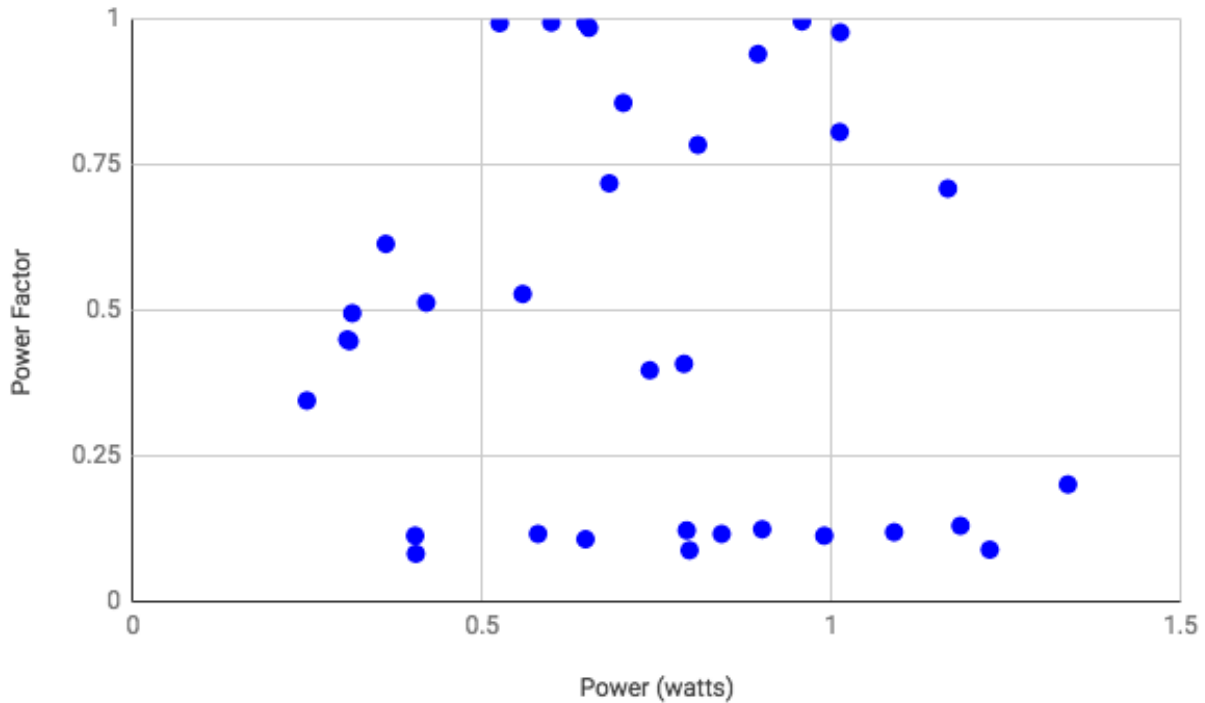

Source: LBNL

Although low power factors in residential equipment are typically not an issue to a utility, the power factor and waveforms of a device can be used to infer the type of power supply used. Five different categories of waveforms produced by the measured devices were identified (Figure 54). Waveform A (resistance) is most likely a resistance voltage divider. Seven outlets and breakers have this waveform and all have almost unity power factor. Waveform B (half-wave) is most likely a half-wave rectifier. Ten devices of all types have this waveform, and power factor can vary from 0.17 to 0.72. Waveform C (Noisy) is most likely an RC voltage divider. Ten alarms and two breakers have this waveform, which has the worst power factor of all, almost entirely due to the capacitor. There are no obvious interpretations for waveform D (square) and waveform E (smooth), but each is used by only one manufacturer.

**Figure 54: Selected Safety, Security, and Health Devices Voltage and Current Waveforms**

**A: Resistance - N = 7, Average PF = 0.98**



**D: Square - N = 3, Average PF = 0.82**

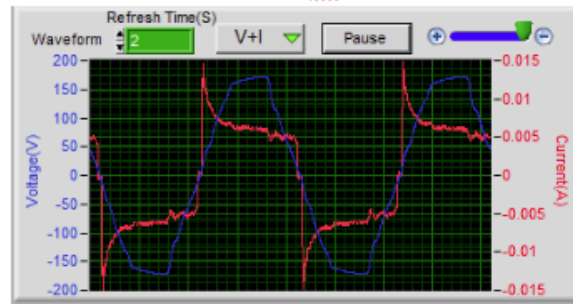

**B: Half-wave - N = 10, Average PF = 0.44**

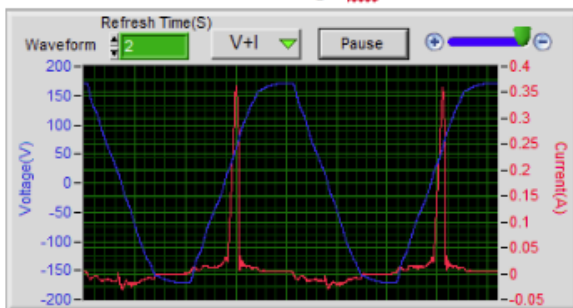

**E: Smooth - N = 2, Average PF = 0.40**

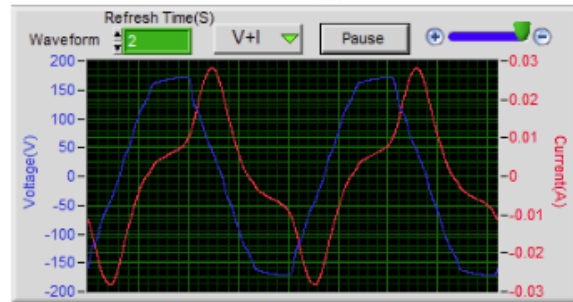

**C: Noisy - N = 12, Average PF = 0.16**

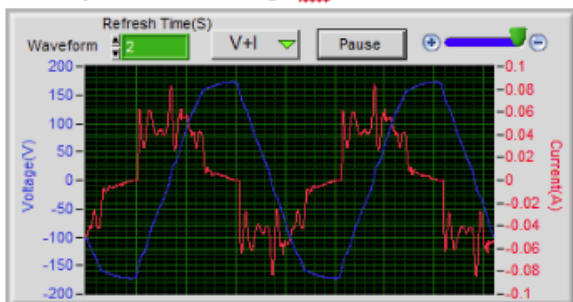

Source: LBNL

Explanations were sought for the variation in power use (Figure 55), including manufacturer, cost, category, waveform, and power factor. No significant correlations were identified other than a very weak one for cost, as shown in Figure 56. Note that although the relationship is quite weak ( $R^2 < 0.2$ ) and mostly driven by the two higher-cost devices, it does show that while low cost ( $< \$25$ ), low power use ( $< 0.5$  W), and higher costs ( $> \$25$ ) do not guarantee low power use.

**Figure 55: Measured Power Consumption of Safety, Security, and Health Devices**

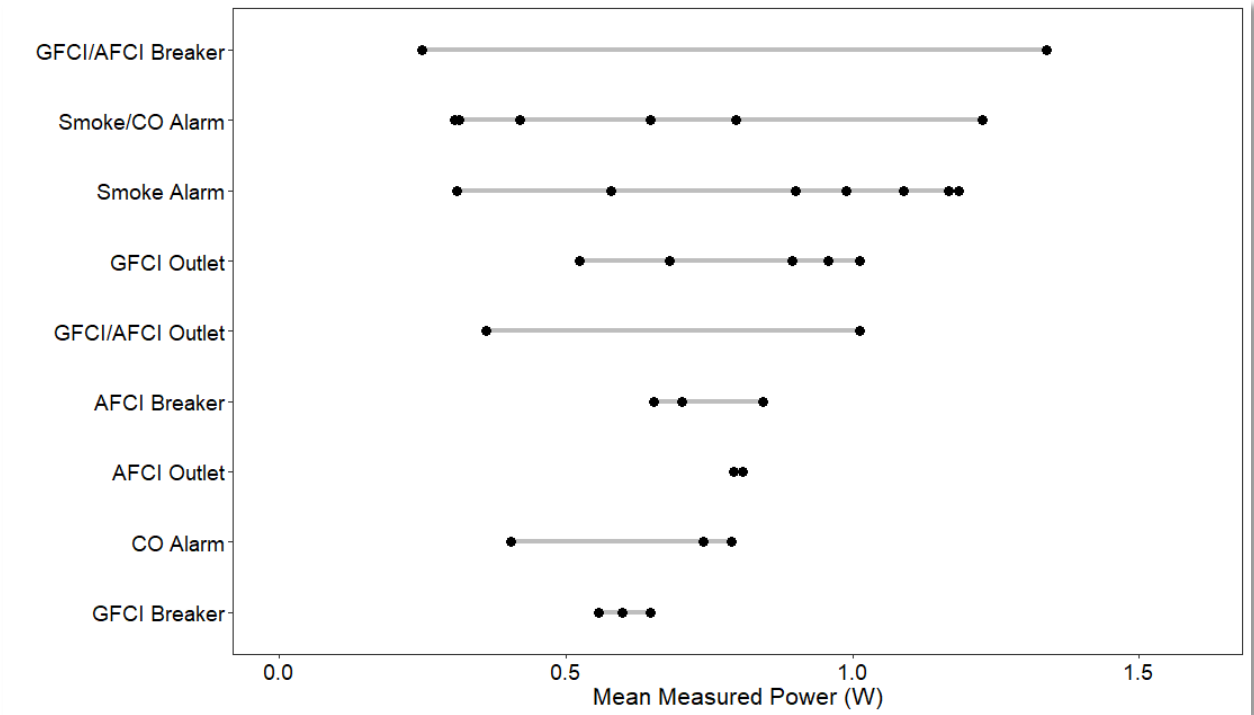

Source: LBNL

**Figure 56: Relationship of Safety, Security, and Health Devices Power Use to Cost**



Source: LBNL

**Teardowns**

Based on data gathered during testing of the residential life-safety SSHDs, five devices were selected for teardowns to try to determine what design factors affected device power use



(Table 16). Low-power devices were selected for teardown because they exhibited minimal power use for their application. Examining the lower-power devices allowed determination of potential areas of further power saving. On the other hand, high-power devices were selected for teardown to contrast them with the low-power ones. Examination of the high-power devices and comparisons to the low-power devices helped explain why some devices use more power than others.

**Table 16: Safety, Security, and Health Devices Selected for Teardown**

Device ID	Category	Power (W)	Power Factor	Cost (\$)	Power Supply	Selection Reason
GFO17	GFCI outlet	1.01	0.98	14	Voltage divider	High power
GFO38	GFCI outlet	0.96	0.96	14	Voltage divider	High power
AGO31	AFCI/GFCI outlet	0.36	0.61	30	Half-wave	Low power
SMA36	Smoke alarm	0.99	0.11	20	RC divider	High power
SMA07	Smoke alarm	0.31	0.45	50	Switcher	Low power

Source: LBNL

### Outlet Teardowns

Several outlets were disassembled to better understand how they were designed and which components used energy.

Figure 57 shows the teardown of the GFO38 GFCI outlet.

**Figure 57: GFO38 GFCI Outlet Teardown**

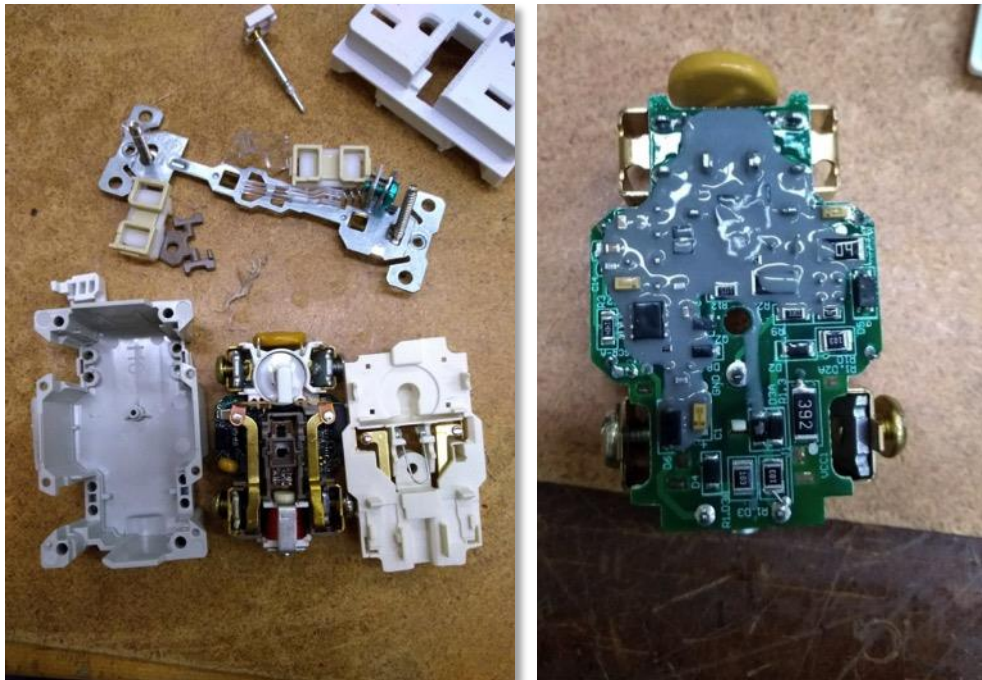

On the left is the mechanical circuit, and on the right is the electrical circuit.

Source: LBNL



The mechanical circuit turned out to be complex. One of the initial suspicions of static power draw from GFCIs and AFCIs was that the relay is normally open, requiring power to hold them closed. From examining the mechanical circuit, however, that was not found to be the case. The mechanical circuit featured a bistable latching mechanism involving two spring forces.

On the electrical side, the GFO38 uses a GFCI IC in the 8-SOP package to implement the ground fault detection logic. GFCI ICs such as the Fairchild RV4141A draw tens of milliwatts of power and do not explain the measured 300–1,000 MW power draw. The power supply that powers the circuit is deduced from looking at the device's input current and voltage waveforms and the circuit components. For this device, the power supply is determined to be a full-wave rectifier with a series resistor to convert 120 V into a lower voltage. If the lower voltage is 10 times lower than the line voltage, then the power supply efficiency using such a circuit is at most 10 percent efficient. Additionally, the low voltage is unregulated.

Figure 58 shows the teardown of the AGO31 AFCI/GFCI outlet, which has the dual functionality of ground fault and arc fault detection. Manufactured by the same company as the GFO38, the mechanical circuits for both were found to be the same, so the mechanical circuit is not pictured. The electrical circuit is much more complex than that of the GFO38 because it detects arc faults, which requires signal processing. Signal processing in turn requires a microcontroller, and a microcontroller requires a stable, regulated voltage.

**Figure 58: AGO31 AFCI/GFCI Outlet Teardown—Electrical Circuit**

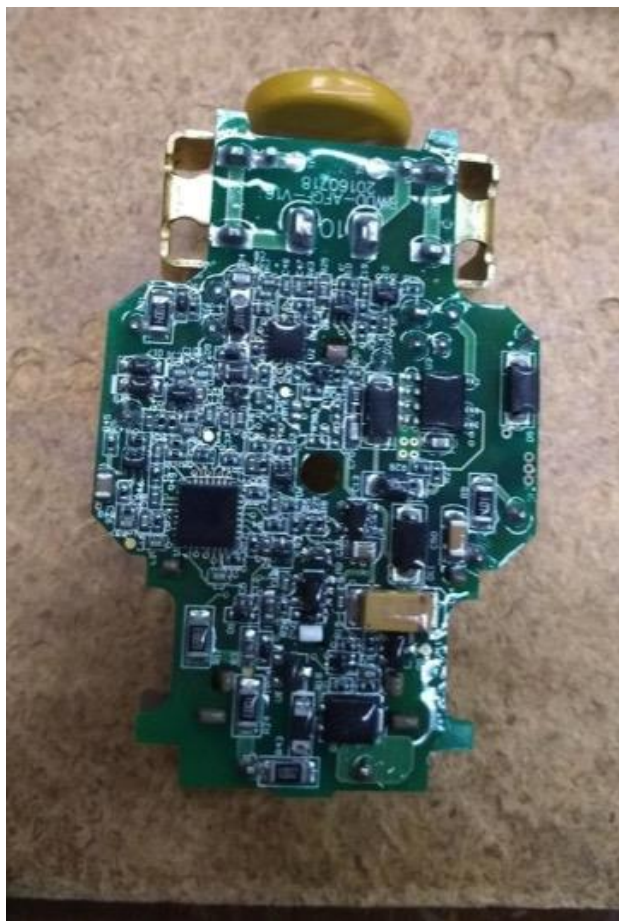

Source: LBNL

The power supply for the AGO31 is deduced to be a half-wave rectifier stage cascaded with a Buck converter from the input voltage and current waveforms and the identification of an inductor on the printed circuit board (PCB). Buck converters are much more efficient than using a resistive voltage divider. Additionally, feedback control can be used to regulate the output voltage.

Figure 59 shows the teardown of the GFO17 GFCI outlet. A different mechanical latching mechanism from the GFO38 and AGO31 was found. A possible IC used is On Semiconductor NCS37010. The circuit uses a silicon-controlled rectifier (SCR) to drive a solenoid that triggers the bistable mechanical circuit, the same process as previous devices. The power supply of this device and the GFO38 were determined to be very similar. A full-wave diode bridge IC can be seen near the upper left, and the resistance to convert voltages can be seen to the right of it in the form of surface-mounted device (SMD) resistors labeled "E81."

**Figure 59: GFO17 GFCI Outlet Teardown—Electrical Circuit**



Source: LBNL

### **Smoke Alarm Teardowns**

Figure 60 shows the teardown of the SMA36, a photoelectric smoke alarm with no wireless networking functionality. It is deduced that the power supply for this device is a resistance-capacitive voltage divider. Cost is most likely the driving factor behind the choice of this circuit.

**Figure 60: Teardown of the SMA36 Smoke Alarm—Electric Circuit**



Source: LBNL

Figure 61 shows the teardown of the SMA07, a photoelectric smoke alarm with wireless networking. There were three PCBs: a main board, the power supply board, and the wireless board. The power supply topology is a Buck converter. The power supply board outputs two voltages: 9 V and 3.6 V. The 9 V output is not well regulated, but the 3.6 V output is. The efficiency curves of both outputs were measured and can be seen in Figure 62.

**Figure 61: Teardown of the SMA07 Smoke Alarm**

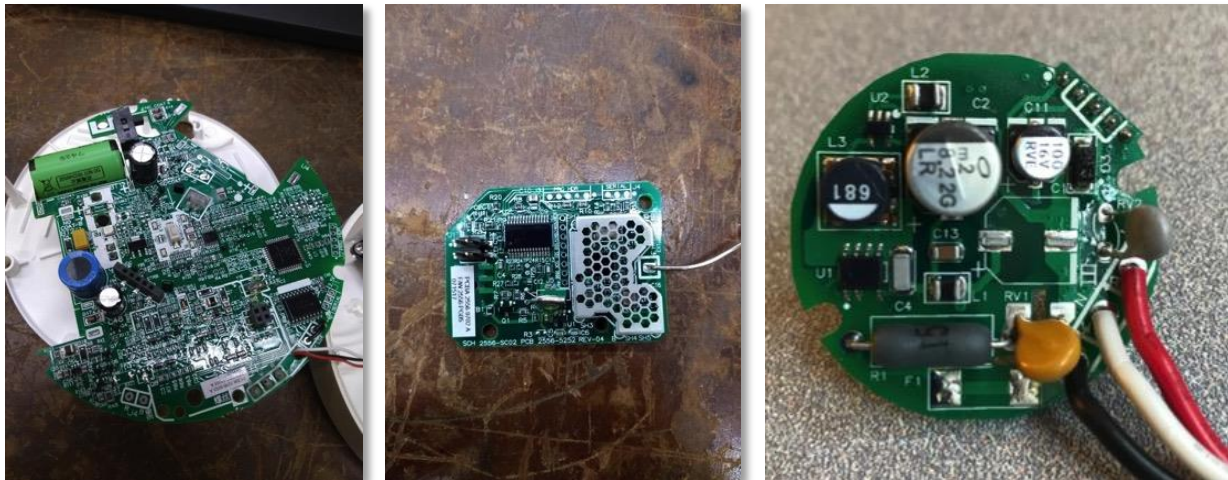

From top left clockwise: main PCB, power PCB, and wireless PCB.

Source: LBNL



**Figure 62: SMA07 Smoke Alarm Power Board Efficiency Curves**

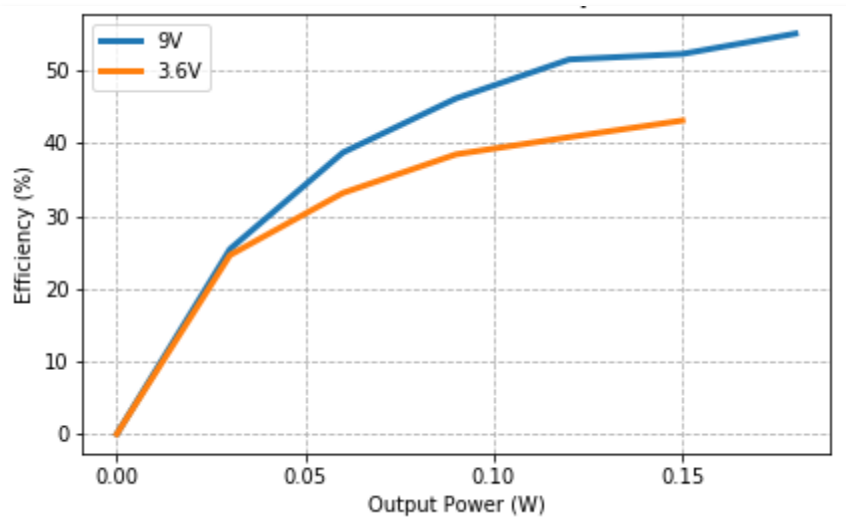

Source: LBNL

### **Overall Observations**

Surprisingly, the smoke alarms and outlets that had more functionality were found to consume less power. While the SMA07 smoke alarm had wireless networking functionality, it consumed less power than all other smoke alarms. Additionally, the AGO31 arc fault/ground fault outlet consumed less power than other ground-fault outlets. It was found that in the more complex devices, Buck converters were being used, probably due to the presence of microcontrollers. The microcontrollers require better quality and regulated power, which cannot be provided by cheaper solutions such as using a resistive divider. Buck converters are much more efficient.

The findings from the teardown suggest that most of the power loss is due to power supply inefficiencies. Supporting this statement is the existence of battery-powered smoke alarms that last several years on one battery. Those smoke alarms draw milliwatts or even less power. Being powered from a battery results in much simpler circuitry, as the battery voltage is already low voltage. When the device is connected to line power, however, there must be additional power electronics to convert between 120 VAC and low voltage. To remain cheap, manufacturers have chosen simple but inefficient methods of achieving that voltage conversion.

## **5. Safety, Security, and Health Devices Energy Use**

Section 4 summarized the laboratory measurements of nine separate categories of life-safety devices, consisting of 34 separate products. These measurements were combined with data on the other selected SSHDs to estimate statewide consumption of the selected SSHDs, which is presented here.

### **Stock and Statewide Energy Consumption**

The stock, sales, and annual energy consumption of SSHDs were calculated based on estimates of device saturation and building construction by year since 1980. This is summarized in Table 17. There is considerable uncertainty associated with some of the underlying data and assumptions. For example, the actual number of GFCIs could be smaller if

installers daisy-chain the outlets together—it is not clear how common this energy-saving (but labor-increasing) measure is undertaken. Behaviors greatly affect the energy use of certain devices, such as ventilation systems and CPAPs.

**Table 17: Stock and Energy Consumption of Safety, Security, and Health Devices in California Buildings**

Device	Stock (millions)	Sales (thousands)	Unit Energy Consumption (kWh/year)	Stock Energy Consumption (GWh/year)	Sales Energy Consumption (GWh/year)
<b>Single Family Homes</b>					
GFCIs	23.4	1,990	7	164	13.9
AFCIs	4.7	527	6	29	3.2
Smoke alarms	19.5	2,219	8	154	17.5
CO alarms	0.8	192	5	4	1.0
Security systems	1.8	311	72	129	22.3
Oxygen concentrators	0.3	33	3,066	1,003	100.3
CPAP ventilators	0.3	53	155	41	8.2
Mechanical ventilation fans	0.1	22	438	46	9.7
<b>TOTAL</b>				<b>1,523</b>	<b>166</b>
<b>Non-Residential Buildings</b>					
Exit signs	6.0	516	21	126	10.8
Emergency lighting	7.1	612	13	94	8.0
<b>TOTAL</b>				<b>187</b>	<b>16</b>

Source: LBNL

Based on these calculations, SSHDs in the average existing California single-family home use about 170 kWh/year. SSHDs in newly constructed homes use about 700 kWh/year (~80 W).

The combined electricity consumption of the installed stock of prominent SSHDs is approximately 1.7 terawatt-hours (TWh) per year, representing about 0.6 percent of California’s electricity use. The residential portion, at 1.5 TWh/year, represents about 1.6 percent of total residential use in California, and the commercial fraction represents 0.1 percent of commercial electricity use.<sup>1</sup> By comparison, residential refrigerators consume roughly 12 TWh/year in California.<sup>2</sup>

<sup>1</sup> The total, residential, and commercial electricity use estimates for California were obtained from <http://www.ecdms.energy.ca.gov/elecbycounty.aspx> for the year 2016.

<sup>2</sup> This assumption is based on an estimate of 1,000 kWh/year being used by a California household’s refrigerator(s), along with an estimated 12 million households in California according to Census data.

Oxygen concentrators have the largest use among the devices examined, about 1 TWh/year. This was an unexpected finding, but not entirely surprising after considering the device's high electricity consumption and the large number of devices in use. Considerable uncertainty surrounds all inputs to this estimate—power, usage characteristics, and stock—but the true value is still likely to be larger than any other SSHD investigated.

The other medical device, the CPAPs, are responsible for much less statewide energy, about 40 GWh/year. The uncertainties surrounding this number are relatively larger than for oxygen concentrators because there are more operational variables. CPAPs have individual adjustments for heating and humidification. These variables drive energy consumption more than pumping, so the unit energy consumption (UEC) is sensitive to assumptions regarding how people select heating and humidification. In any event, oxygen concentrators consume much, much more.

The UEC of mechanical ventilation systems is also high. At slightly over 400 kWh/year, this represents about 5 percent of an average California home's total electricity consumption. The high consumption arises from a relatively high-powered fan operating continuously. Mechanical ventilation systems would consume much more statewide energy except that most people switch them off—allowances were made for this—and the small fraction of homes that have them. As new homes replace older ones and remodeling occurs, electricity consumed for mechanical ventilation will become much larger (assuming occupants operate them as intended and don't switch them off), eventually resulting in about 5 percent of total residential electricity use. There is still time to develop technologies and policies that both maintain indoor air quality and avoid this increase in electricity use.

GFCIs are responsible for only about 7 kWh/year in today's average California home. This corresponds to about 160 GWh/year. The combined energy consumption of the code-required life-safety equipment is about 350 GWh/year, or about 0.3 percent of current, statewide residential electricity use. This consumption will grow steadily for at least two decades through renovations and new construction. Figure 63 shows the historical rise in number of SSHDs in California homes as a result of code changes.

**Figure 63: Growth in Residential Life-Safety Devices Required by Building Codes**

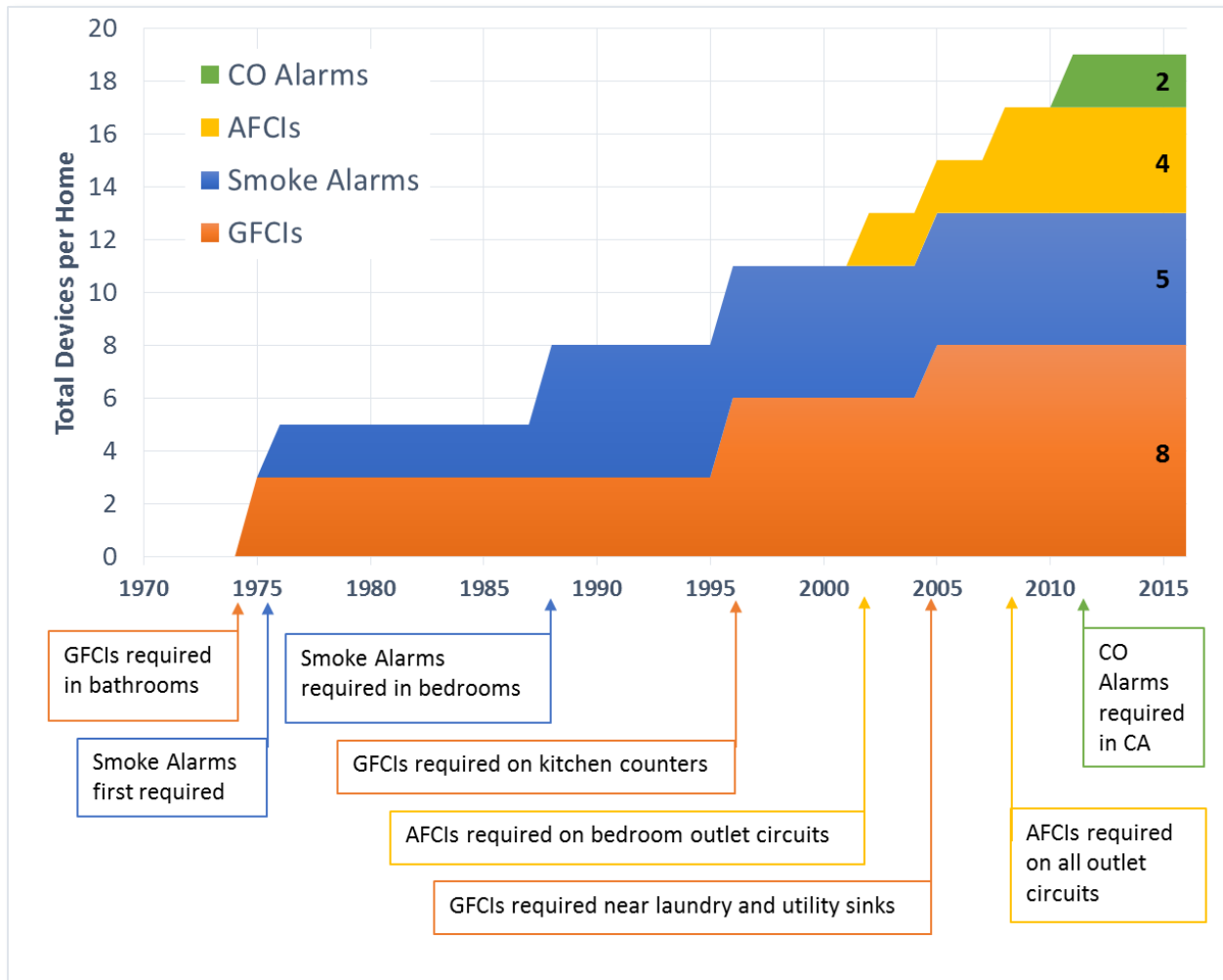

Current number of individual devices are shown on the right.

Source: LBNL

## 6. Prospects for Energy Reductions in Safety, Security, and Health Devices

The stock and energy consumption of SSHDs in California’s buildings will surely grow. More SSHDs will be installed as new homes and commercial buildings are built and existing buildings are renovated. But increases beyond this natural upgrade are also likely as new kinds of SSHDs appear. It is easy to imagine increases above 200 kWh/year for each California home. The battery backup to open garage doors, which just became mandatory through recent legislation, is an example of a response to a safety threat. This device alone will add up to 100 kWh/year for each garage door in California. Surveillance systems, which provide security around homes, will also become commonplace. These systems will consume up to 90 kWh/year per home. Home medical equipment already ranks among the most energy-intensive devices in homes, but its high consumption will probably not be a barrier to further

growth. Its energy consumption may be high, but those costs will be far less than they would be for hospitalization, and the value of independent living is immeasurable.

As a result, the primary policy goal will be to minimize growth in SSHD energy use rather than reduce it. The following sections outline strategies to constrain growth in California SSHD energy use.

## **Laboratory Research**

A sustained research effort should be undertaken to improve the energy efficiency of devices where health or safety considerations prevent innovations. This research needs to be carefully linked to the health and safety communities to understand their service needs, identify technical solutions, and field-test prototypes. The first two targets should be oxygen concentrators and mechanical ventilation systems.

For oxygen concentrators, research questions include:

- Can concentrators be designed to more closely adjust their power requirement to match oxygen delivery rates (such as power scale)?
- Are patients receiving more oxygen than they require?
- Can improved sensing and algorithms result in less wasted oxygen delivery?
- Are other concentrating technologies ultimately more efficient?
- Are patients using concentrators correctly? Can the user interface be improved to avoid wasted oxygen?
- Can Internet-connected devices enable more precise treatment regimens and, ultimately, less wasted oxygen?
- Can surplus electricity from on-site PV be used to concentrate and store oxygen?
- What are the most effective points to enter the development cycle to help encourage use of more efficient approaches?

The problem is different for mechanical ventilation systems because occupants appear to be switching off the systems and exposing themselves to poor indoor air quality to avoid thermal discomfort and noise. Here the goal is to increase ventilation, which leads to higher electricity consumption. More precisely, the goal is convincing occupants to take other measures to reduce their exposure to indoor air pollutants. Some of this research crosses into social science and public policy. The research questions include:

- Can ventilation systems be designed to be quieter and cause less thermal discomfort?
- What technical measures can be implemented to make operation of the systems more desirable, and how can these be achieved with the lowest-possible energy penalty?
- What new sensors, algorithms, and controls can be installed to reduce thermal and audio discomfort and encourage higher utilization?
- Given the reluctance of occupants to operate fans continuously, what combination of consumer acceptance, health impacts, and ventilation energy has the lowest overall social cost?



- Can ventilation systems be more closely linked to Internet-connected thermostats to provide better control and feedback to occupants?
- Why do consumers decide to disable their ventilation systems?

The technologies employed in GFCIs and smoke alarms proved to be surprisingly complex and resistant to inspection of individual components. In addition, the devices had unexpectedly high part counts. Further research will still be required to identify energy savings (if they exist). Potentially the savings could be obtained in conjunction with reduced parts count, leading to lower costs.

For smoke and CO alarms, research should be undertaken to eliminate the need for a power supply. This could be accomplished through a 10-year battery, possibly combined with energy harvesting and wireless networking. This solution will require building codes to be changed but could significantly reduce installation costs.

Further research is also needed to understand the usage of CPAPs and the opportunities to save energy; for example, whether local sensing and algorithms can be developed to minimize heating/humidification energy.

### **Programmatic Activities**

Most SSHDs consume little energy, and therefore offer correspondingly small energy savings, even when reductions of 50 percent are technically feasible. The efficiency improvements may still pay for themselves in reduced operating costs, but even though they will pay for themselves, consumers, contractors, and others will not spend time or money implementing the changes because the payoff is so small. Government, utilities, and other entities need to design programs that require little or no additional effort on the part of consumers, contractors, and other decision-makers to shift from current products to the most efficient available. Possible actions include the following:

- Support labeling efficiencies of medical equipment.
- Establish minimum-efficiency requirements for key SSHDs, such as for GFCIs.
- Include high-efficiency SSHDs in specifications for premium home designations.
- Offer rebates for high-efficiency garage-door battery systems.
- Educate contractors on energy-savings from daisy-chaining GFCIs.
- Establish energy test procedures for SSHDs.
- Educate healthcare providers on the energy impacts of medical equipment and measures that can reduce them.
- Determine if ventilation codes can be designed to reflect actual occupancy.

These actions illustrate the range of participants that must be involved to ultimately save energy.

California (and other entities) face an administrative problem related to SSHDs. Who should be responsible for SSHD energy use? Presently nobody is. For example, efficiencies of exit lights fall in Title 20 (appliance standards) but installation of GFCIs is covered by building codes. No entity has responsibility for energy use of medical equipment. Indeed, the DOE is prevented from addressing these devices. This situation probably cannot be fixed; however, an "SSHD

Coordinating Council” might bring disparate groups together to encourage energy savings. One of the council’s early goals might be to coordinate battery back-up capacity for SSHDs and other priority devices.

## **7. Conclusions**

This investigation identified a unique category of energy-using devices that provide life safety, health, and security for buildings. The installation or use of these devices is dictated by building codes, health providers, insurance companies, and other entities. None would ordinarily consider energy efficiency a feature. These devices are part of the MELs end use category.

While not particularly large today, SSHD energy use will steadily climb as existing buildings begin to comply with new codes and new types of SSHDs appear. Also, these estimates understate their total contribution because devices now appearing or shifting from elective products into SSHDs were not covered (such as modems, WiFi access points, optical network terminals, and batteries for garage door openers). This growth helps explain why MELs are projected to grow faster than any other end use.

There are diverse strategies to reduce future SSHD energy consumption (or slow growth rates). For some devices, such as GFCIs and mechanical ventilation systems, the best-available models consume less than half as much power as typical models. It appears that efficiencies of medical equipment could be greatly improved through better compressors and controls. Battery-charging systems for a host of devices can also be made more efficient. Completely new solutions, possibly relying on custom ICs, could also offer energy savings.

At the same time, reducing the energy consumption of SSHDs is challenging. Most SSHDs consume little energy and therefore offer correspondingly small energy savings, even when reductions of 50 percent are technically feasible. The efficiency improvements may still pay for themselves in reduced operating costs, but even though they will pay for themselves, consumers, contractors, and others will not spend time or money implementing the changes because the payoff is so small. Few people will devote an hour searching for an SSHD that uses 5 kWh/year—about \$1—less electricity.

A second obstacle is that higher priorities determine the performance and characteristics of many SSHDs. These range from safety—electrical and fire—to health. Energy impacts rarely enter into the policymaking decisions for these devices (or, if they do, it is to exempt the devices). A coordinating council might help by raising the profile of energy use in these devices.

An important element of this investigation involved careful measurement, inspection, and teardown of SSHCs. With this information, the goal was to first identify how these devices actually used energy and then to propose lower-energy solutions. Unfortunately, these devices were more resistant to teardowns and detailed measurements than expected. As a result, it was not possible to identify as many savings opportunities as anticipated.

Because of their broad diversity, no obvious administrative entity manages SSHDs. Because the list of SSHDs will grow, establishing a coordinating council might therefore make sense. The council’s goal would be to bring energy and operating-cost impacts into policy discussions regarding future SSHDs.

## 8. Future Work

A sustained research effort will be needed to improve the energy efficiency of devices where health or safety considerations hinder innovation. This research needs to be carefully linked to the health and safety communities to understand the service needs, identify technical solutions, and field-test prototypes. The first two targets should be oxygen concentrators and mechanical ventilation systems.

For oxygen concentrators, research includes the following:

- Design units to more closely adjust their power requirement to match oxygen delivery rates (such as power scale).
- Improve sensing and algorithms to waste less delivered oxygen.
- Determine if other concentrating technologies ultimately are more efficient.
- Consider out-of-the-box solutions such as novel concentrating methods and use of PV to concentrate and then store oxygen for later delivery.

The problem is different for mechanical ventilation systems because occupants switch off the systems and expose themselves to poor indoor air quality to avoid thermal discomfort and noise. Here the goal is to increase ventilation, which leads to higher electricity consumption. More precisely, the goal is convincing occupants to take other measures to reduce their exposure to indoor air pollutants. Some of this research crosses into social science and public policy. The research topics include the following:

- Design ventilation systems to be quieter and cause less thermal discomfort.
- Improve new sensors, algorithms, and controls to reduce thermal and audio discomfort, encourage higher utilization, and reduce energy use.
- Use Internet-connected thermostats to provide better control and feedback for occupants.

The technologies employed in GFCIs and smoke alarms proved to be surprisingly complex and resistant to inspection of individual components. In addition, the devices had unexpectedly high part counts. Further research will still be required to identify energy savings (if they exist). The savings might be obtained in conjunction with reduced parts count, leading to lower costs.

Further research is also needed to understand the usage of CPAPs and their opportunities to save energy. For example, can local sensing and algorithms be developed to minimize the heating/humidification energy consumed by these devices?

### Programmatic Activities

Most SSHDs consume little energy and therefore offer correspondingly small energy savings, even when reductions of 50 percent are technically feasible. Government, utilities, and other entities need to design programs that require little or no additional effort on the part of consumers, contractors, and other decision-makers to shift from current products to the most efficient available. Possible actions include the following:

- Label efficiencies of medical equipment.

- Establish minimum efficiency requirements for key SSHDs, such as for GFCIs.
- Include high-efficiency SSHDs in the specifications for premium home designations.
- Offer rebates for high-efficiency garage-door battery systems.
- Educate contractors on energy-savings from daisy-chaining GFCIs.
- Establish energy test procedures for SSHDs.
- Educate health-care providers on the energy impacts of medical equipment and measures that can reduce their electricity demands. These actions illustrate the range of participants that must be involved to save energy.

# CHAPTER 5: Very-Low-Power Standby Products: Implications for Codes, Standards, and Test Methods

---

## 1. Scope

Electrical devices that draw no—or very little—power in their standby modes are relatively new phenomena whose behaviors are not fully captured in current codes and standards. These devices (which are a subset of plug loads) typically draw very little power but, because billions are in use, they still represent significant aggregate energy consumption in buildings. This chapter reviews current applicable codes and standards for zero-standby and very-low-power devices. The scope is broader than only energy characteristics because some zero-standby solutions have characteristics with impacts on electromagnetic radiation, health, and materials.

How do these new technologies interact with the ecosystem of test methods and applicable efficiency and health standards? A general overview of the interaction between codes and standards, test methods, and products is provided in Figure 64. Test methods are designed to measure certain product characteristics that are regulated or required by codes and standards. This chapter first discusses relevant test methods and then the codes and standards (although these are sometimes difficult to separate). Finally, the implications of characterizing and regulating products with zero- or very-low-power standby features are discussed.

**Figure 64: The Relationship Between Codes and Standards, Test Methods, and Products**

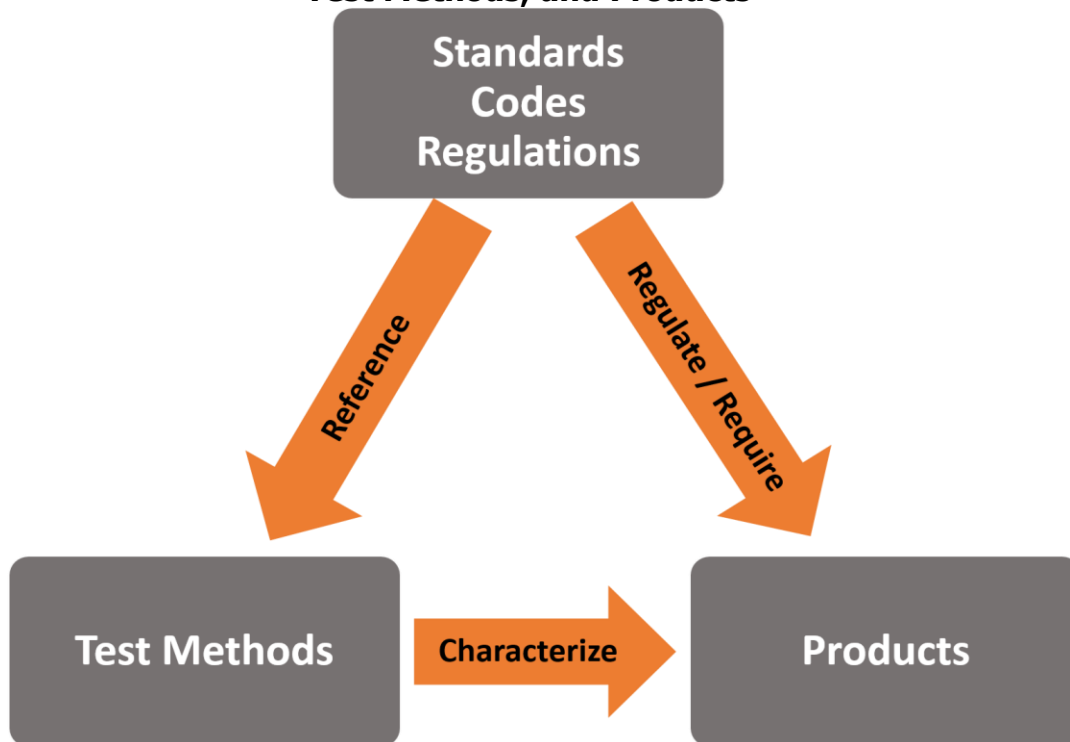

Source: LBNL

This investigation is part of a larger project to understand and develop very-low-energy plug loads—what this report calls “ZNE plug loads”—that will ultimately provide essential services in sustainable buildings of the future (Meier 2015). Other parts of the project involved developing technologies to enable zero, or near-zero, standby power and identify future applications of these solutions.

## **Test Methods**

Test methods provide a consistent (and agreed-upon) procedure to assess the behavior of a device, material, and (recently) service. New test methods are needed whenever new devices, materials, and services appear or have a new application. This is the case for zero-standby technologies. They have different behaviors with respect to energy, materials, health, and safety. Current test procedures are reviewed as they apply to the energy, health, and safety of zero-standby and direct DC-powered products and identify areas where gaps may exist.

## **Energy**

A consistent procedure for the measurement of standby power—actually for all low-power modes—is essential for any policy or program seeking to measure it. This project has already identified or developed several new solutions that transform standby power from a fairly constant load into a load with much more beneficially diverse behavior. This transformation is reflected in the standzero concept and technologies like the zero-standby power supply, the wake-up RF system, and direct DC-powered appliances. The California Energy Commission (Energy Commission) is currently gathering comments on ways to collect data to characterize low-power modes for a wide variety of products, using a common test procedure.<sup>3</sup> Issues discussed in the document include wired and wireless network connections, sensors, rechargeable peripherals, DC power, and systems of devices.

## **Standby and Low-Power Modes**

Low-power modes are typically measured with procedures established by the International Electrotechnical Commission (IEC) 62301 test method (International Electrotechnical Commission 2011). The test methods described in 62301 fall into three categories: sampling, average reading, and direct meter reading. All take place in carefully specified conditions to ensure consistency of results. The sampling method is required where power is not stable or the mode is of limited duration. Sampling is the only method permitted for cyclic loads and short-duration modes. The original IEC 62301 test method was designed to address AC-powered products with relatively stable consumption. Furthermore, the product boundary was clear and environmental conditions were not especially important. IEC 62301 has been incorporated into many energy-consumption test methods, examples of which are listed in Table 18.

---

<sup>3</sup> Request for Public Comment on Low Power Mode Test Procedure Discussion Document. <https://efiling.energy.ca.gov/GetDocument.aspx?tn=223875>

**Table 18: Examples of Standby Energy Use in Other Test Methods**

<b>Method by Which Standby is Measured</b>	<b>Applicable Products (not comprehensive)</b>	<b>Description</b>
IEC 62301	Dishwashers, battery chargers, clothes washers, furnaces, microwaves ovens, etc.	IEC 62301 is referenced by the relevant test method for the product.
Captured in active-mode test cycle	Refrigerators, water heaters	Energy use of controls is included in the aggregate energy metric.
IEC 62087	Audio/video equipment	Covers on mode only.
IEC 62623	Desktop and notebook computers	Off mode is measured and added to the total electric consumption.
(CFR) part 430, subpart B, appendix M	Air conditioner condensing units	Off-mode seasonal power and energy consumption is measured and reported separately from seasonal energy efficiency ratio (SEER).

Source: LBNL

### **Direct Direct-Current**

Low-voltage direct DC-powered consumer products have traditionally been used in four areas: (1) off-grid, (2) marine, (3) recreational vehicles (RV), and (4) the public switched telephone network (PSTN). DC-powered products are now appearing in grid-powered buildings with the advent of managed DC networks such as power over Ethernet (PoE) and USB. However, energy-test methods for most DC-powered products in buildings are relatively new and are still evolving.

DC-powered products have a growing potential in developing countries, where grid power is unavailable, intermittent, or expensive. Some of the standards activities have taken place outside of the IEC and other technical standards entities. For example, the Clean Energy Ministerial energy access initiative has developed the Global LEAP program, which supports energy access in the developing world. For this purpose, Global LEAP has developed test methods for off-grid TVs, fans (pedestal, table, and ceiling), and refrigerators,<sup>4</sup> which typically operate with a DC power input. These methods are mostly based on existing IEC methods for AC-powered products (IEC 62087 for TVs, IEC 60879 for fans, IEC 62552 for refrigerators, and IEC 62301 for standby power). These methods allow testing with a DC cable and DC power supply, or an AC power supply and an AC/DC converter, depending on whether the product is intended for direct-DC or AC power input, and using the power cable provided with the product.

For solid-state lighting (SSL) products, the Illuminating Engineering Society (IES) LM-79-08 specifies a test method for both AC- and DC-powered products. For the latter, LM-79 requires measurement of input DC voltage and input DC current using a DC voltmeter and DC ammeter

<sup>4</sup> For existing and under development test methods developed by the Global LEAP program, see Global LEAP Off-Grid Appliance Test Methods at <http://globalleap.org/resources/>.

between the DC power supply and the SSL product to derive input DC power. Similar measurements are specified for DC-powered LEDs in LM-82-12, which characterize LED light engines and LED lamps at varying temperatures.

The ENERGY STAR program has established a test method for Large Network Equipment (LNE), including PoE switches and routers, and is applicable to both AC- and DC-powered network equipment (U.S. EPA 2015). This test method specifies measuring current, voltage, and power between the tested unit and the power source. However, the ENERGY STAR method for Small Network Equipment (SNE) excludes DC-powered equipment.<sup>5</sup>

## **Health and Safety**

In addition to energy test methods, other non-energy test methods may still apply to zero-standby solutions. These include safety, health, and radiation standards and their underlying test methods.

The health effects from wireless devices and systems that rely on RF or microwave radiation to function are still debated (Lin 2016). Test methods have been established to measure exposure. It is not clear that zero-standby devices incrementally contribute more radiation than other devices with higher standby power levels. Indeed, efficiency measures taken to enable lower standby may also contribute to lower radiation.

None of these test methods appear to pose major obstacles to zero-standby solutions, although some of them may be new to manufacturers (such as lasers). Nevertheless, manufacturers will still have to devote resources to comply with them.

Some zero-standby solutions require energy storage with batteries and capacitors, which will have materials impacts. Life-cycle assessments of batteries have been undertaken for a wide range of technologies, though most have focused on large units suitable for utility or electric-vehicle applications (Larcher and Tarascon 2015) though some assessments of super capacitors for electronics applications have been investigated (Smith et al. 2018). Procedures for performing life-cycle assessments have become more standardized; however, they have not yet evolved into internationally recognized test methods directly applicable to zero-standby products and materials.

## **2. Codes and Standards**

### **Scope**

In the same way that current test methods no longer apply, current codes and standards will no longer capture new behaviors of zero-standby technologies. The current codes and standards are reviewed as they apply to zero-standby technologies and identify areas where gaps may exist.

Low-power and direct-DC products can fall under three distinct regulatory categories: (1) regulated by energy codes, (2) exempt from energy codes, and (3) required by building codes. In the first category, codes and standards regulate the standby energy use of products

---

<sup>5</sup> SNE differs from LNE primarily due to the number of physical network ports (11 or less for SNE, 12 or more for LNE), and whether it is mounted on standard equipment racks or not.



used in buildings. In the second category, energy codes can specifically exempt products, including many medical devices and home-security products, from minimum efficiency requirements. In the third category, building health and safety codes require specific products but are silent with respect to energy consumption. Examples include GFCIs and smoke alarms. Thus, low-standby technologies must be designed in a complex, potentially inconsistent regulatory environment. Some of the complexities and inconsistencies follow.

### Energy Codes and Standards

Numerous entities have current energy codes and standards for plug loads that consider their low-power mode use, including the DOE, the Energy Commission, and ENERGY STAR (voluntary), which are summarized here.

### California Energy Commission Codes and Standards

The Energy Commission, via Title 20, has test methods and standards for a variety of plug load appliances, as summarized in Table 19. Note that the Energy Commission covers more appliances than those provided in Table 19; however, the appliances provided in Table 19 are limited to those with low-power-mode measurements and/or standards.

**Table 19: Low-Power-Mode Testing and Standards in California Appliance Energy Standards**

<b>Appliance Category</b>	<b>Title 20 Standards Section</b>	<b>Low-Power and Off Mode Measurements</b>
Gas and Oil Space Heaters and Electric Residential Boilers	1605.1(e) 1605.3(e)	Measures off mode and standby mode using IEC 62301. The efficiency standard for boilers is based on the annual fuel utilization efficiency (AFUE). Maximum standby loss and maximum consumption during standby are specified for natural gas and liquefied petroleum gas (LPG) boilers rated at least 300,000 Btu/h and duct furnaces, respectively.
Room ACs, Room AC Heat Pumps, Packaged Terminal ACs, and Packaged Terminal Heat pumps	1605.1(b)	Measures total energy use during a defined cycle and period, which includes low-power modes.
Water Heaters	1605.1(f)	Total site standby energy (including electrical) is measured over the standby period, which is roughly the period of time between two water draws. A standby heat loss coefficient for the storage tank is calculated and incorporated into the calculation for the uniform energy factor (UEF). The efficiency standard for water heaters is based on the UEF.
Hot Water Dispensers	1605.1(f)(4)	Only measures standby energy use over a 24-hour period. The result is reported as the standby loss (in watts).

<b>Appliance Category</b>	<b>Title 20 Standards Section</b>	<b>Low-Power and Off Mode Measurements</b>
Televisions	1605.3(v)(2)	Measures off mode and standby modes using IEC 62301 procedures.
Washing Machines	1605.1(p)	Calculates an integrated modified energy factor (IMEF) which uses the per-cycle combined low-power mode energy consumption (averaged over a year) as measured by IEC 62301 procedures.
Dishwashers	1605.1(o)	IEC 62301 procedures are used to measure off mode and various low-power modes to calculate the annual combined low-power mode energy consumption.
Refrigerators, Refrigerator-Freezers, and Freezers	1605.1(a) 1605.3(a)	Measures total energy use during a defined cycle and period, which includes low-power modes. However, many newer, electronic features (displays, Internet connection, etc.) may be switched off during the test, thus lowering the apparent non-active power consumption. California regulations also cover wine chillers with a modified Energy Expended equation.
Lights	1605.1(k) 1605.3(k)	For lamps capable of operating in standby mode (such as smart lamps), measure standby power using IEC 62301 procedures. California has additional requirements for standby power in Table K-1 to ensure: that the lamp is connected to only one network, that it be measured for not less than 60 minutes, and that it be measured at a lamp that is 10 meters from the hub.
External Power Supplies	1605.1(u) 1605.3(u)	Standby- and no-load power measurements taken at different loading conditions. Instantaneous power readings can be used if the power draw is stable; otherwise, IEC 62301 procedures are used.
Battery Chargers	1605.3(w)	Unit energy consumption (UEC) calculation requires measurements of standby and off-mode power consumption, which are taken as the time series integral of the power consumed over a 10-minute test period, divided by the period of measurement. The annual UEC for standby and off modes incorporates an assumed daily hours of operation based on product class. Maintenance mode and no-battery mode

Appliance Category	Title 20 Standards Section	Low-Power and Off Mode Measurements
		power consumption limits are specified for large battery charger systems, small battery charger systems, inductive charger systems, and battery backup and uninterruptible power supply (UPS) systems (only requirement for maintenance mode).
Audio and Video Equipment	1605.3(v)(1)	Test method for standby-passive mode is IEC 62087:2002(E). Maximum power consumption is specified for compact audio products in audio standby-passive mode and DVD players and recorders in video standby-passive mode (Table V-1 of section 1605.3(v)(1)).
Computer Monitors	1605.3(v)(4)	The test method for sleep mode and off mode is IEC 62301.
Computers	1605.3(v)(5)	The test method is the ENERGY STAR Program Requirements for Computers, Final Test Method with modifications, and it is carried out according to the requirements in IEC 62623.

Source: LBNL

### U.S. Department of Energy Appliance Standards

The Energy Independence and Security Act of 2007 (EISA) requires DOE to take standby power use into account.<sup>6</sup> Therefore, a number of appliances covered by the DOE Appliance and Equipment Standards program have required low-power mode consumption measurements and/or standards in place. A summary of these standards, as codified in the Code of Federal Regulations (CFR), is provided in Table 20.

---

<sup>6</sup> Section 310(3) of EISA 2007; Pub. L. 110-140 (codified at 42 U.S.C. 6295(gg)) amended the Energy Policy and Conservation Act (EPCA) to require that energy conservation standards address standby mode and off mode energy use.

**Table 20: Low-Power Mode Testing and Standards in Federal Appliance Energy Standards**

<b>Appliance Category</b>	<b>CFR Standards Section</b>	<b>Low-Power and Off Mode Measurements</b>
Gas and Oil Space Heaters and Electric Residential Boilers	10 CFR 430.32(e)	Measures off mode and standby mode using IEC 62301 procedures. The efficiency standard for boilers is based on the annual fuel utilization efficiency (AFUE).
Washing Machines	10 CFR 430.32(g)*	Calculates an integrated modified energy factor (IMEF) which uses the per-cycle combined low-power mode energy consumption (averaged over a year) as measured by IEC 62301 procedures.
Dishwashers	10 CFR 430.32(f)	IEC 62301 procedures used to measure off mode and various low-power or standby modes to calculate the annual combined low-power mode energy consumption.
Refrigerators, Refrigerator-Freezers, and Freezers	10 CFR 430.32(a)	Measures total energy use during a defined cycle and period, which includes low-power modes. However, many newer, electronic features (displays, Internet connection, etc.) may be switched off during the test, thus lowering the apparent non-active power consumption.
External Power Supplies	10 CFR 430.32(w)	Power supplies (with some exceptions) manufactured on or after February 10, 2016, must meet standards for maximum power in no-load mode (10 CFR 430.32(w)(ii)).
Battery Chargers	10 CFR 430.32(z)	Unit energy consumption (UEC) calculation requires measurements of standby and off-mode power consumption, which are taken as the time series integral of the power consumed over a 10-minute test period, divided by the period of measurement.

\* Clothes washers manufactured on or after March 7, 2015, and before January 1, 2018, have different IMEF standards than those manufactured on or after January 1, 2018.

Source: LBNL

### **ENERGY STAR**

In addition to Energy Commission and federal standards, ENERGY STAR has voluntary standards covering low-power modes for many appliances. Table 21 summarizes the ENERGY STAR low-power-mode requirements.

**Table 21: Low-Power-Mode Testing and Standards in ENERGY STAR Product Specifications**

<b>Appliance Category</b>	<b>Relevant Qualification Criterion</b>	<b>Description</b>
Clothes Dryers	Combined energy factor (CEF)	CEF is the ratio of the test load weight (lbs) to the sum of the standby and off mode energy consumption and the per-cycle energy consumption (kWh). The CEF must be greater than or equal to a specified minimum (based on product type).
Audio and Video Equipment	Sleep mode power	Sleep mode power must be less than a specified maximum (based on product function).
Computers	Desktops, notebooks, tablets, and thin clients: <ul style="list-style-type: none"> <li>• Typical energy consumption (<math>E_{TEC}</math>)</li> </ul> Workstations: <ul style="list-style-type: none"> <li>• Weighted power consumption (<math>P_{TEC}</math>)</li> </ul> Small-scale servers: Off mode power	$E_{TEC}$ and $P_{TEC}$ are the time-weighted energy and power consumption across modes (including off and sleep modes), respectively. These metrics must be less than maximums that are based on product type and function. The off mode power consumption of small-scale servers must be less than 1 W (or 1.4 W for products having a wake-on-LAN feature enabled by default).
Displays	Computer monitors: <ul style="list-style-type: none"> <li>• Typical energy consumption (<math>E_{TEC}</math>)</li> </ul> Signage displays: <ul style="list-style-type: none"> <li>• Sleep mode power</li> </ul> All displays: Off mode power	$E_{TEC}$ is the time-weighted energy consumption across on and sleep modes. This must be less than or equal to a specified maximum (based on monitor area). Sleep mode power for signage displays must be less than or equal to a specified minimum equal to 0.5 W plus allowances for product features. Off mode power for all displays having off mode must be less than or equal to 0.5 W.
Game Consoles	Standby mode power	Standby mode power must be less than or equal to 0.5 W.
Telephony	Off mode power	On mode power, less an off mode power incentive (calculated as 0.25 multiplied by the difference in on and off mode power consumption), must be less than or equal to a specified maximum (based on product features).
Televisions	Standby-passive mode power and standby-active, low-mode power	Standby-passive mode power must be less than or equal to 0.5 W. Standby-active, low-mode power must be less than or equal to 3 W.

<b>Appliance Category</b>	<b>Relevant Qualification Criterion</b>	<b>Description</b>
Connected Thermostats	Network standby average power consumption	Network standby average power consumption must be less than or equal to 3 W.
Room Air Cleaners and Purifiers	Standby mode power	Standby mode power must be less than or equal to 2 W.
Electric Vehicle Supply Equipment	No vehicle mode power	No vehicle mode power must be less than 2.6 W plus allowances for the network connection with wake capability and high-resolution display.

Source: LBNL

### **Health and Safety Codes**

Building codes may require installation of devices to limit the risk of electrocution, fire, and other health and safety hazards. A summary of the residential health and safety devices required by building codes is presented in Table 22. Responsibility for these devices is divided among various organizations. In general, Underwriters Laboratories (UL) defines the operation and test methods for all aspects of a device’s performance. State and local building codes dictate the numbers and locations of the devices in homes and typically reference codes developed by the National Fire Protection Association (NFPA). Changes to these products that reduce their energy use need to be compatible with the relevant UL standard, but would not affect how they are treated by the relative NFPA code. As mentioned earlier, the number of life-safety devices in homes has been steadily increasing since they were first required in the 1970s. (See Figure 63.)

**Table 22: Residential Health and Safety Devices Required by Building Standards**

<b>Device</b>	<b>Code/Standard</b>	<b>Purpose</b>
Ground-Fault Circuit Interrupter (GFCI)	NFPA 70 UL 943	Protect people from electric shock
Arc-Fault Circuit Interrupter (AFCI)	NFPA 70 UL 1699	Protect building from fires started by arcing wires
Smoke Alarm	NFPA 101 UL 217	Warn occupants of fire and smoke
Carbon Monoxide (CO) Alarm	NFPA 720 UL 2034	Warn occupants of dangerous CO levels

Source: LBNL

## **Other Health Considerations**

As previously discussed, new behaviors and materials associated with very-low-power devices are liable to introduce new health effects that must be considered. In this section, some of the requirements for these devices are discussed.

Devices that emit electromagnetic radiation are subject to regulation by the Federal Communications Commission (FCC) and, in some cases, the FDA. The FCC is required by the National Environmental Policy Act of 1969 to evaluate the effect of emissions from FCC-regulated transmitters on the quality of the human environment. In 1996 the FCC adopted maximum permissible exposure limits for field strength and power density for transmitters operating at frequencies of 300 kHz to 100 GHz, as well as specific absorption rate limits for devices operating within close proximity to the body (Federal Communications Commission 2015). The Center for Devices and Radiological Health of the FDA is responsible for regulating manufacturers of electronic products that emit (or could emit) radiation; however, by law the FDA does not regulate radiation-emitting products before they can be sold. If devices are found to emit potentially harmful levels of radiation, the FDA then has the authority to step in and require the manufacturer to notify consumers, replace the device, or recall the device (U.S. FDA 2018).

Additionally, the FDA helps regulate products employing lasers, which could be used to supply energy in zero-standby energy-harvesting devices. Laws, regulations, and standards exist to help manage any hazardous effects from each of the four laser classes the FDA recognizes (U.S. FDA 2019).

For some products—and especially those incorporating some form of energy storage—considerations must be taken for end-of-life material disposal. The Restriction of Hazardous Substances (RoHS) and Waste Electrical and Electronic Equipment (WEEE) directives exist in the European Union and thus can influence U.S. products that are also sold abroad. In addition, there are various local waste-disposal regulations such as California’s Electronic Waste Recycling Act of 2003.

Finally, many medical devices are currently exempt from energy standards. As an example, power supplies and certain battery chargers classified as devices for human use under the Federal Food, Drug, and Cosmetic Act (and requiring FDA listing and approval as a medical device), are exempt from California’s appliance-efficiency regulations (California Energy Commission 2017).

None of these standards appear to pose major obstacles to zero-standby solutions, although some of them (such as lasers) may be new to manufacturers. Nevertheless, manufacturers will still need to devote resources to comply with them.

## **3. Discussion**

Aspects of zero-standby technologies that will complicate their coverage by test methods and standards are discussed in this report. The following discussion is based on the investigations previously described.

## Zero-Standby Solutions

It was explained earlier in this report how IEC 62301 is used to measure the power consumption in low-power modes for a variety of plug loads. Table 23 lists the aspects of IEC 62301 that must be modified in order to accommodate new standby operating characteristics. The two modifications with the greatest energy impact appear to be boundary definitions and energy storage. Some of the solutions require a separate transmitter (or possibly just a remote control) that provide power designed to be harvested. The transmitter would most likely be a separate device with its own power consumption. The presence of energy storage—a battery or capacitor—complicates the test method because the state-of-charge must be considered during measurements. In both cases, some approaches might be adapted from existing test methods, such as those for battery chargers and wireless charging. For example, harvesting a transmitted signal’s energy is a form of wireless charging (albeit an extremely weak form).

**Table 23: IEC 62301 Test Method Changes Required to Account for Zero-Standby Solutions**

Test Aspect	Reason for Modification
Power supply (assumes mains or AC powered)	The power supply options must include DC. DC should include conventional DC power as well as “Managed DC” (such as USB and Ethernet).
Modes	Certain modes, such as disconnected, off, and network connected, will require new definitions to accommodate energy harvesting of communications signals.
Boundary conditions for DC-powered products	Define whether to include energy consumption of remote power supplies (AC-to-DC and DC-to-DC) feeding the product.
Environmental conditions for energy-harvesting products	Power consumption may vary with environmental conditions such as the amount of light or range of temperature. Include standard environmental conditions to obtain consistent values for energy contributed by the environment (deliberate or incidental) and greater control of the test room.
Duration of power measurements	The presence of batteries and capacitors to store energy may require much longer (or different) testing conditions.
Instruments for power measurements	Lower power consumption may require greater resolution (below 1 mW).
Mobile operation (and intermittent connection to mains power)	The expectation of frequent and extensive mobile operation needs to be taken into account.
Type of energy harvesting	To fairly test the product, the type(s) of energy harvesting must be identified. This information will enable the tester to appropriately set the test conditions and procedure.

Source: LBNL

These are substantial modifications and may require comprehensive review. Ultimately, the best potential approach may be to start over and devise an entirely new energy test method (or methods).



Earlier investigations have shown that some zero-standby solutions will include energy storage and energy harvesting (Meier 2018). Several prototypes were developed that rely on harvesting the energy from an infrared or laser signal, and then charging a capacitor with that harvested energy. The stored energy is sent as a wake-up drive signal to the gate of a footer switch. In the prototypes, this footer switch is an N-type MOSFET that connects the grounds of the device (plug load) and the device’s power supply. Before the footer switch is activated, no power is consumed by the device because its ground is not connected to the supply ground. Such prototypes could allow a device to operate with zero standby consumption for essentially indefinite periods of time.

Standzero (a term derived from “standby-zero”) is the elapsed time a product can operate while disconnected from grid-supplied electricity (Meier and Siderius 2017). Thus, standzero has the dimension of time. The standzero concept is already familiar to hundreds of millions of users of smart phones and other portable electronics because it is similar to the operating time until recharging is required. Homes with optical networks where telephone service is also included must have batteries whose standzero time is specified (typically a few hours). Users of portable oxygen concentrators know the standzero times of their units, because their lives may depend on it.

Products with any amount of standzero time will employ some form of energy storage (such as battery or capacitor). Additionally, devices may harvest ambient energy from lighting, infrared signals, vibration, or other means. Figure 65 depicts possible implementation of these technologies. The test method will therefore need to specify an initial state for the energy storage as well as standardized environmental conditions for the energy harvesting.

**Figure 65: Rendering of Possible Components of a Standzero Device, Including Energy Harvesting Means, Energy Storage, and Logic to Control Electricity Flow Between Mains, Storage, and Harvested Energy**

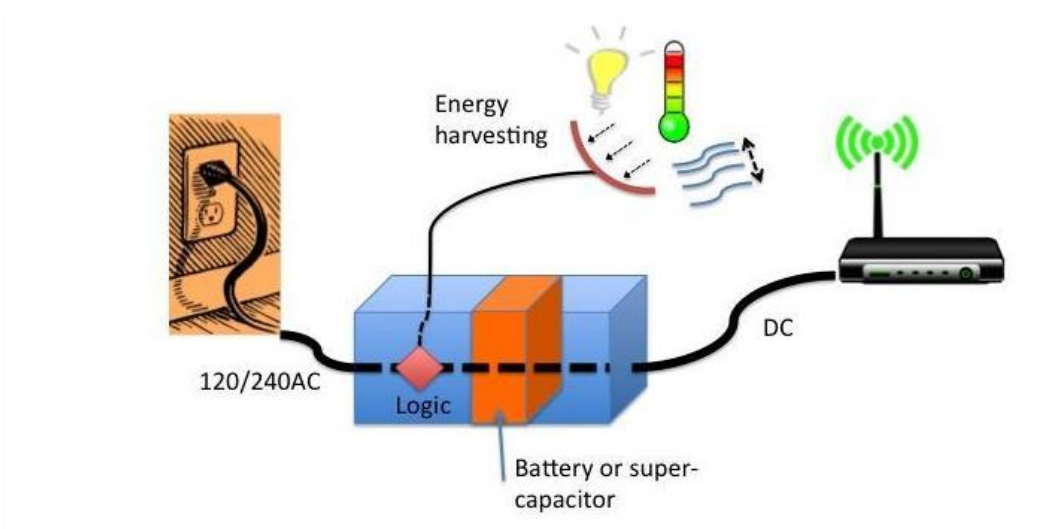

Source: LBNL

No accepted method for measuring standzero exists today, even though related metrics are widely used to describe performance in numerous appliances. A standzero test method will need to specify an initial state for the energy storage (such as battery state of charge) as well

as standardized environmental conditions (such as incident lux or temperature) for any energy-harvesting capability. The dynamics of standzero operation must be considered in the test method. For some products, standzero operation will be an intermittent behavior, whereas in others standzero operation will be the dominant type of behavior. Some devices will have sufficient energy harvesting and storage capability to always power its minimum load in standzero fashion. Such an appliance would have an infinite standzero time.

To address some of these considerations, one can draw upon existing test procedures. This might be an extension of an existing test method (such as IEC 62301) or a completely new test method. For instance, IEC 62257-9-5<sup>7</sup> contains test methods for off-grid lighting product performance after mains charging, electromechanical charging, and solar charging (a given product would necessarily be powered by one of these means). Prior to performing these test procedures, the product's battery is brought to a specific state of charge (essentially its fully discharged state) before the specified charging and performance measurement takes place. Similarly, the storage component of appliances with standzero capability needs to be brought to a standardized state (fully charged or fully discharged) prior to subjecting the appliance to environmental stimuli (energy harvesting) and measuring the standzero time. Additionally, the solar charge test in IEC 62257-9-5 specifies standard conditions for how the product is to be charged based on product-specific energy harvesting characteristics. Any standzero test would also need to specify standard environmental conditions from which the appliance can harvest energy. As an example, one might imagine that the test procedure for a standzero-capable television that harvests visible light requires that the television be placed under lighting conditions (such as lux levels) typical of a household's living room. Of course, there are many nuances to consider, but some examples of the issues involved in specifying test procedures for standzero technologies are listed below:

- Combination of a time-performance test with measurement of power (the measured time with 0 watts power draw)
- Specification of environmental conditions of the test
- Definition of the state-of-charge of the battery or capacitor
- Duration of the test, including characterization of any periodic standzero intervals

The test boundary for zero-standby technologies also requires clarification. Many zero-standby solutions harvest power from an external source (such as a laser or radio signal). How should these sources be included in the standby measurements? A future test method must provide guidance. Development of a standzero test method is additionally challenging because there is no obvious precedent upon which to build.

Finally, low-standby products such as thermostats, smart speakers, and video cameras have network connections functioning in their lowest modes. The network connection can induce energy consumption by equipment upstream, all the way to the cloud. The network consumption is typically small, on the order of 0.06 kWh/GB transmitted (Aslan et al. 2017),

---

<sup>7</sup> Recommendations for renewable energy and hybrid systems for rural electrification - Part 9-5: Integrated systems - Selection of stand-alone lighting kits for rural electrification

but how the data are used and stored can induce a wide range in upstream-power consumptions. These impacts were not investigated in this report.

### **Direct Direct-Current-Powered Devices**

DC-powered devices will no longer have a dedicated power supply converting mains AC to DC. This complicates testing since the device power consumption must be measured in terms of DC rather than AC. How should power supply losses (both fixed and variable) be captured when no dedicated power supply exists?

Although most energy test methods, such as IEC 62301, specifically exclude DC-powered products, most of their elements could be transposed into a DC test method or modified to accommodate both AC and DC products. The chief issue is whether to account for the upstream AC-to-DC transformation losses. Consider a product such as a router, which has two versions that are identical save that one is mains-powered and the other is direct-DC powered (from a USB or other source). The DC model would always consume less energy because the power supply losses do not get captured. This would be accurate in the case where the DC power is provided by a native source such as PV, but more typically (at least currently) there would be losses at the AC-to-DC conversion.

One method to improve comparability is to calculate net-energy consumption for DC products; that is, the difference between the combination of product and power supply and the power supply alone. ENERGY STAR adopted this approach for its imaging equipment specification (U.S. EPA 2014). ENERGY STAR assumed that the power supply's consumption does not change in the two conditions (with and without a load).<sup>8</sup>

### **Life-Safety Devices**

Life-safety devices were examined in considerable detail because they are unique in the aspect that they are required by code. The growth of these devices (Figure 63) and their concomitant energy use is significant. The measurements both in new homes and the lab indicate that the cumulative impact of these products in new homes can exceed 200 kWh/year. It is not clear if these products should be treated within building codes or in minimum efficiency standards (such as within California Title 24 or Title 20). This growing collection of products deserves attention by policy makers.

## **4. Conclusions**

Test methods, codes, and standards do not yet capture the unique features of ZNE plug loads and products with zero or very-low-standby power. Those unique features span energy-consumption behavior, materials, and health and safety. Establishing test methods and standards is especially challenging because each product has a small environmental footprint—drawing less than a few watts of power and consisting of only a few grams of materials—but the cumulative impact of billions of these products is enormous.

---

<sup>8</sup> This assumption may fail when the product begins communicating with the power supply so that the power supply adjusts its behavior depending on product mode. Power over Ethernet and USB make communication much simpler.

The most important findings and recommendations are summarized here:

- For nearly all energy test methods, the boundaries of measurement need to be reconsidered to reflect new behaviors of the technologies. The boundaries include upstream-energy use, the environment, and duration of measurement.
- All test methods and standards need to take into account that more and more products will operate for long periods unconnected to the grid. This phenomenon is not just limited to portable electronics: think EVs and autonomous vacuum cleaners. The testing dilemma is how to define (and measure) standby modes when “disconnected” may be a common configuration.
- Energy test methods for DC products need to be updated to reflect the anticipated increase in higher-power DC products. The ultimate goal should be comparable treatment of AC and DC products.
- Future zero-standby solutions may require manufacturers to comply with new health and safety requirements. For example, lasers might be used to enable energy harvesting. None of these requirements appear insurmountable.
- For DC products, the boundaries of the measurements need to be better defined; for example, how should upstream DC power supplies be treated?
- For mobile products and those with standzero capability, test methods need consistent procedures to account for energy storage and environmental energy harvesting.
- Life cycle assessments of materials associated with low-standby technologies need further investigation. Most studies of energy storage, for example, focus on much larger products.
- As some appliances approach zero grid energy, what is an appropriate energy test method?
- Health and life-safety devices are presently exempt from most energy standards and codes. The project results suggest that the aggregate energy use for these products is growing.

Adoption of zero and near-zero standby solutions will require research along several avenues to help understand the implications of this transformation. Some recommendations to those related to test methods, codes, and standards are listed here below:

- Develop consistent energy-bookkeeping procedures to reflect the network-related energy consumption induced by a product. Devices may not be using grid power for operation, but they may be inducing upstream-energy use by virtue of their high communications/data/cloud processing loads. In other words, when a product either transmits or receives a byte of data in the course of controlling its operation, how much additional energy consumption is induced in the local network and in the cloud?
- The low-power mode test method, IEC 62301, may require entirely new sections describing procedures to measure behavior of devices with energy harvesting and storage. Greatly extending the measurement interval to capture harvesting and storage/discharge behaviors will probably not be sufficient. IEC 62301 should also be extended to include standzero, that is, to define measurement methods that

characterize unplugged behavior. These modifications will require research in addition to administrative updates.

- Define a consistent method based on smart-meter data to determine a new home's standby losses before occupancy. Once defined, this measurement could be used in local or statewide energy codes (such as "not to exceed 100 watts").

This chapter described the test methods, codes and standards that apply to a set of products in the midst of a rapid technological evolution. Even if the exact direction of the transformation of plug loads is not clear, appropriate test methods, codes and standards will provide a transparent framework for evaluation by manufacturers, policymakers, and consumers.

# CHAPTER 6: Supplemental Research

---

## 1. Introduction

Several research activities did not neatly fit in earlier chapters so are presented here. Further GFCI measurements were undertaken when additional devices were obtained from Japan. The back-up batteries for garage door openers were studied because legislation in late 2018 made them mandatory. A subcontractor created a prototype of a DC power network with storage and renewable power that was built upon findings from several chapters in this report. Plug loads in commercial buildings were also examined. Some of this research is continuing through support from other sources.

## 2. Further Ground-Fault Circuit Interrupter Measurements

The original measurement plan included GFCI and combination GFCI/AFCI devices, both as outlets and breakers. Two GFCI plug adapters available in Japan (Figure 66) were obtained late in the project. These adapters are used for installing appliances that require GFCI protection (such as washing machines and washlet-toilets) on circuits that do not have a GFCI. The measured devices had much lower power use than any of the GFCI devices tested so far. Therefore, for comparison, five U.S. GFCI plug devices were tested to check if the low power use was related to the device type or the country of origin.

**Figure 66: Japanese Ground-Fault Circuit Interrupter Plug Adapters**



Source: LBNL

A summary of the GFCI plugs tested is shown in Table 24. Three of the U.S. devices were plug adapters similar to the Japanese models; that is, they plug into a standard 120 V outlet and provide a single GFCI protected outlet, while the other two were add-ons to the plugs, which are designed to be installed at the end of an appliance cord to provide GFCI protection to the appliance (Figure 67).

**Table 24: Ground-Fault Circuit Interrupter Plug Measurements**

Device ID	Plug Type	Origin	Reset Mode	Cost (\$)	Average Power (W)	Power Factor
GFP48	Adapter	Japan	Last	21	0.09	0.74
GFP49	Adapter	Japan	Last	32	0.17	0.72
GFP50	Replacement	U.S.	Powered	17	2.24	0.98
GFP51	Adapter	U.S.	Last	15	0.27	0.99
GFP52	Adapter	U.S.	Powered	11	1.90	0.71
GFP53	Adapter	U.S.	Tripped	16	1.29	0.69
GFP54	Replacement	U.S.	Powered	20	2.65	0.99

Source: LBNL

**Figure 67: GFP52, a Plug Adapter (left), GFP50, a Replacement Plug (center), and GFP51 (right)**



Source: LBNL

The behavior of the devices after loss of power also differed. While all GFCI outlets tested returned to the state they were in before the loss of power (they are persistent), four of the U.S. plug devices exhibited different behaviors: one model always started in tripped (no power) mode, while the other three always started in powered mode. Also note that both replacement devices started in powered mode; this may be a feature when used on devices such as pumps or refrigerators.

The average power use of the U.S. GFCIs was 1.67 W. One model, however, drew just over 0.25 W. The Japanese models drew much less power. Both drew less than 0.20 W, with one model drawing only 0.09 W (or 5 percent of an average U.S. GFCI).

Efficiency does not appear to cost more. Models GFP50 and GFP51 are produced by the same Chinese manufacturer (Shenzhen Nandao Electromachinery Co.), and their cost is within \$2 of each other, yet one uses more than eight times more power than the other. One possible explanation is that GFP51 may also be sold in the EU market and must therefore meet the 0.5-W European Union standby standard. There is also no correlation between price and efficiency among the Japanese units: the most efficient Japanese unit costs significantly less and draws half as much power.

### 3. Back-Up Batteries for Garage Door Openers

Some garage doors are equipped with back-up batteries that enable operation during power failures. California recently enacted legislation (Dodd 2018) requiring all new garage doors to be equipped with back-up batteries. This action was in response to several deaths during recent wildfires where people were unable to exit their garages when the power was interrupted. This legislation mandates the installation of a new plug load—the battery charger—in many California homes. The energy implications of this new SSHD were investigated to provide data for policy makers. It was also envisioned that the door opener could be incorporated into a DC network and energy storage services shared by several devices.

Five garage door openers with battery back-up systems were acquired and tested. No energy test procedure exists for these devices, so a simple procedure was developed. Power use was measured with a fully charged battery connected and without a battery connected. Preliminary results are listed in Table 25.

**Table 25: Standby Power of Five Garage Door Openers with Batteries (Preliminary)**

Device	Battery					Garage Door Opener Power (W)		
	Type	Capacity (Ah)	Nominal Voltage	Charged Voltage	Float Charge (mA)	With Battery	Without Battery	Difference
GDO55	Li-ion	4	18	20.48	—	14.617	14.119	0.498
GDO56	lead-acid	5	12	15.03	200–250	—	—	5.623
GDO57	lead-acid	5	12	13.36	25	8.491	8.178	0.313
GDO58	lead-acid	4.5	12	12.86	3–4	12.237	3.493	8.744
GDO59	lead-acid	5.4	12	13.35	1	7.53	7.538	–0.008

**Note:** Ah = ampere hour

Source: LBNL

The addition of a battery back-up increased electricity use an average of roughly 3 W. However, the values ranged from 0 to almost 9 W. The consumption appears to be sensitive to conditions and configuration, so a more complex testing method is needed. (This is often the case for devices with batteries.)

The battery must be replaced periodically—some manufacturers recommend every two years, though consumers report two to five years—which has its own cost and materials burden. The annualized costs of the electricity for recharging and batteries are about the same.

### 4. Low-Voltage Direct Current Home Networks

Earlier in this report it was noted that low-voltage DC networks had potential benefits in homes. These DC networks could save energy by providing direct DC power to efficiently



operate several communications, lighting, and other plug loads. By equipping the network with a small, dedicated PV collector and battery, the system also could provide power to key services during a power interruption. Ultimately, it might be able to supply modest demand response when dual-power appliances are available. The system normally operates with power from the PV and battery; when no solar energy is available and the battery is depleted, power could be drawn from the grid. (However, power would flow only in one direction.) A DC network would save energy because it would connect the PV sources to the batteries with a very small voltage adjustment. This provides extremely high efficiencies, since a system like this is designed to closely match the voltages of a PV source to that of the storage batteries. This report identified garage door openers, optical fiber boxes, medical equipment, and sump pumps as devices that would benefit from such a system. Later, as dual-powered appliances (that is, capable of operating on either AC or DC) are developed, other small loads could be attached.

As a proof of concept, a small DC network was created based on PoE. Figure 68 shows a block diagram for the system. The present network is connected with USB-PD (Power Delivery); however, it could be upgraded to PoE.

Components were either fabricated or acquired, and a bench model of the proposed system was assembled (Figure 69). One intended feature will be scalability; that is, the ability to add storage and PV capacity as the number of devices connected to the network grows.

The system is currently under test. Early results indicate that its primary goals were achieved; that is, collecting solar energy, storing, and managing its distribution to various loads, and interacting with the grid.

**Figure 68: Block Diagram for a Residential Low-Voltage Direct Current Network**

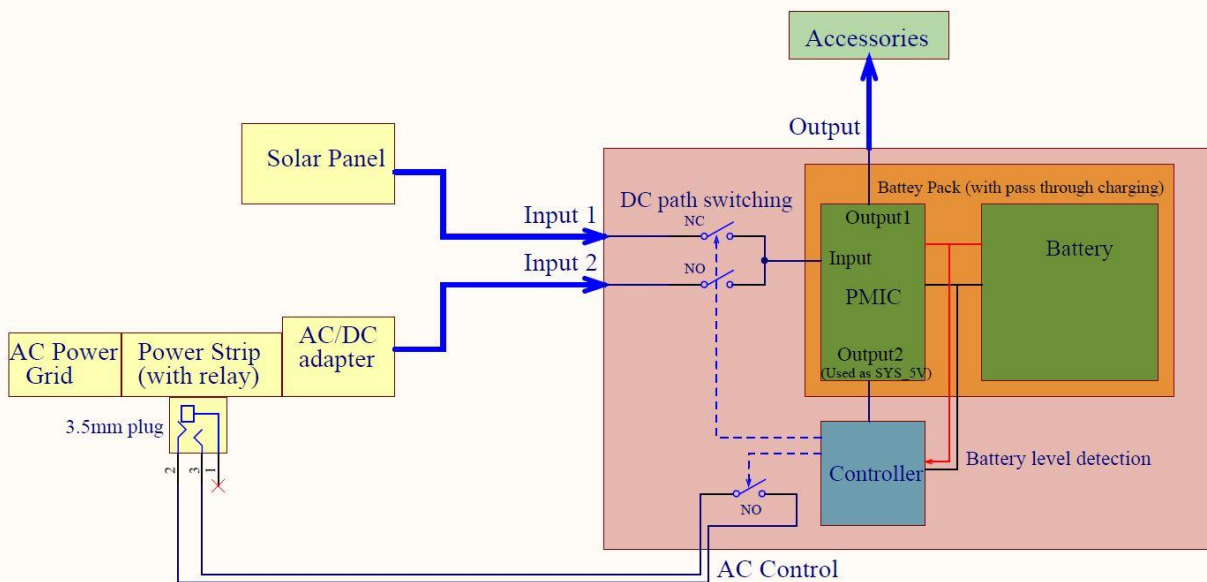

Source: Belkin

**Figure 69: Bench Assembly of a Low-Voltage Residential Direct Current Network with Two Loads**

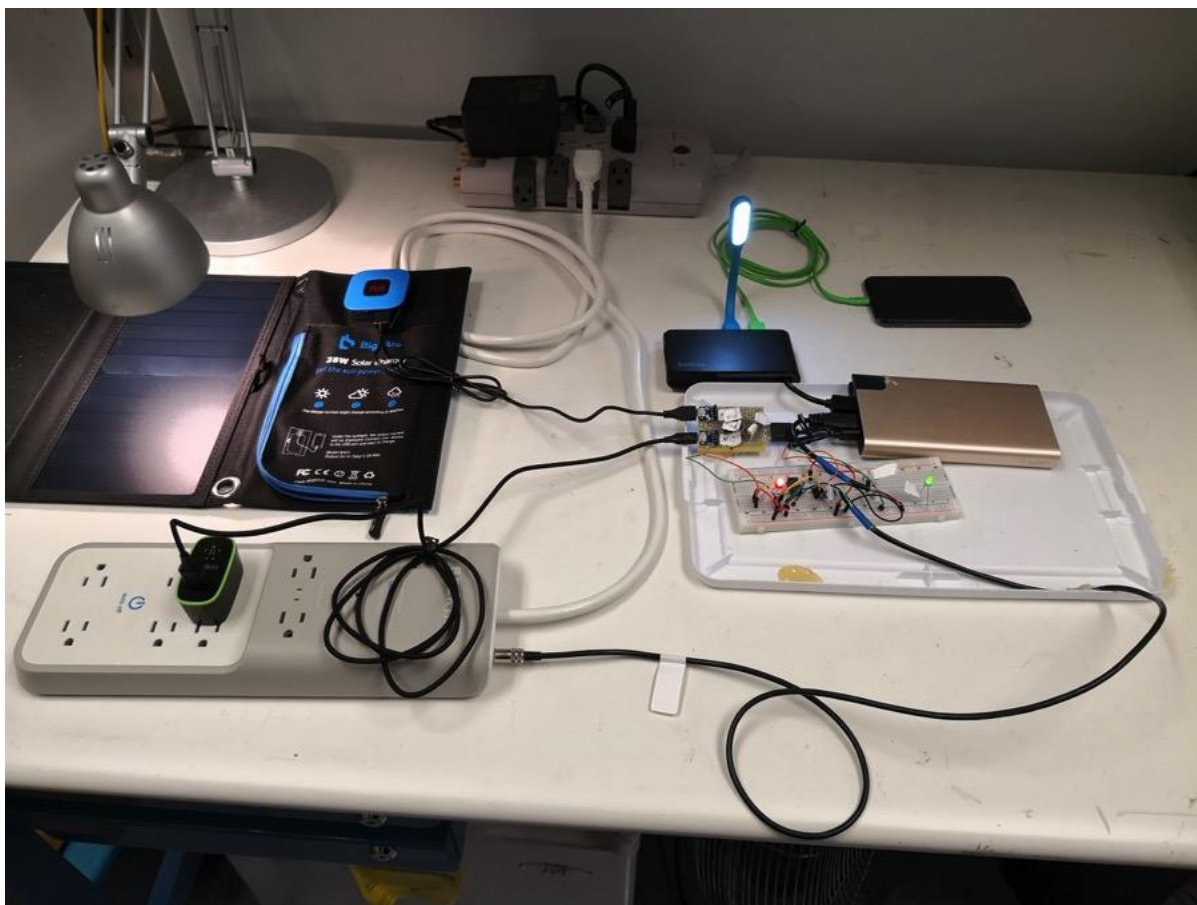

Source: Belkin

## **5. Plug Loads in Commercial Buildings**

Plug loads in commercial buildings differ substantially from those in homes. To be sure, there is some overlap—many commercial buildings have kitchens, for example—but they also have unique devices and usage patterns. This research focused on residential buildings but undertook two studies of plug loads in commercial buildings.

### **Plug Loads in a Zero-Net-Energy Commercial Building**

The energy performance of a ZNE office building in Northern California was investigated from the perspectives of simulation, measurement, verification, and code compliance. Simulations of the building's energy use were undertaken during the design stage to demonstrate code compliance, and measurements of actual energy use were taken for six months after occupancy. Total energy use determined from simulations was nearly equal to that determined by measurements, but actual HVAC and lighting energy use were lower than the simulations by 34 percent and 26 percent, respectively. Actual plug energy use was more than 800 percent higher than the results from the simulations. Reconciliation of simulations and actual energy use was made more complicated by the inconsistencies in categories. Water heating energy disappeared as a separate end use because decentralized, plug-in units replaced a central unit and became a plug load. An "other" energy use was not present in the

energy simulation, whereas energy measurements included it. Details of this investigation are published in Koyanagi and Meier (2017).

### **Laboratory Measurements of Plug Load Devices Specific to Commercial Buildings**

There is surprisingly little documentation about the energy consumption of life-safety equipment installed in commercial buildings. Many of the devices are difficult to measure because they are hard wired. Some of the most common devices were measured to determine if their consumption is significant, and the measurements are summarized in Table 26.

**Table 26: Measurements of Commercial SSHDs**

<b>Device</b>	<b>Description</b>	<b>Cost (\$)</b>	<b>Average Power (W)</b>	<b>Power Factor</b>
elt45	Emergency Egress Light	20	1.98	0.60
exl46	Combination Exit/Emergency Egress Light	89	3.22	0.83
exs47	Exit Sign	58	2.92	0.78

Source: LBNL

These are relatively low-power consumptions but, like in homes, dozens of these devices may be present in a commercial building.

# CHAPTER 7:

## Project Benefits

---

### 1. The Role of the Electric Program Investment Charge

For most plug loads, manufacturers face the dilemma that consumers will pay little attention to energy-saving improvements. Most products do not (and probably will not) have energy labels to alert customers to efficient products. This market arrangement discourages research into more-efficient technologies. Electric Program Investment Charge (EPIC) funding is needed to make advances in these three related areas for the detailed reasons described below.

For zero-standby power supplies and devices, power-supply and device manufacturers have shown increasing interest in energy efficiency and the role of power supplies in ZNE buildings, but their approach has been to implement incremental rather than holistic improvements. In addition, power-supply and device manufacturers are skilled in conditioning and managing power but not in energy harvesting, storage, and communication. Since power-supply and device manufacturers are unlikely to fund the changes explored in this research, EPIC funding is needed to push the envelope of what is possible. Some of the prototypes developed for this project are shown in Figure 70. These are being shown to manufacturers for possible commercialization.

**Figure 70: Standby Reduction Prototypes**

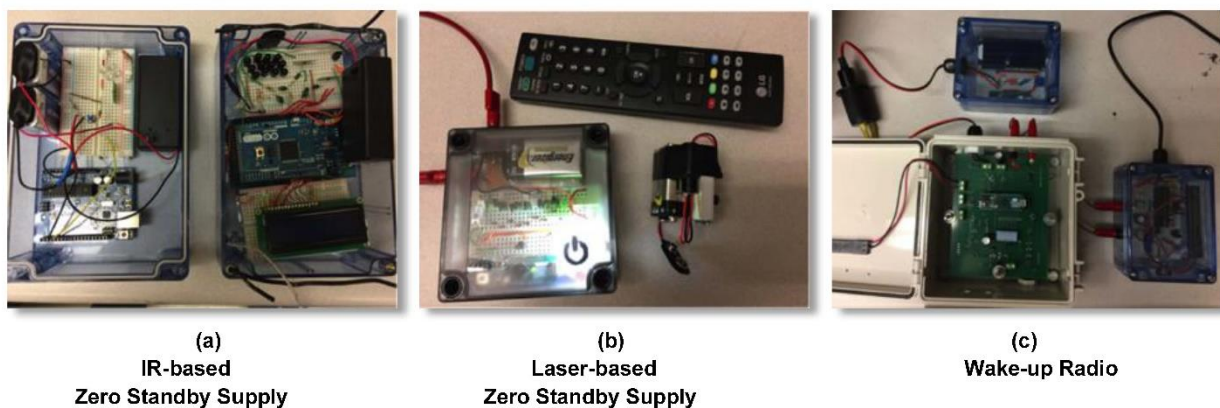

Source: Daniel Gerber

For DC-powered products, manufacturers and other DC power advocates, such as the Emerge Alliance, have been trying for years to increase adoption of DC power in buildings. EPIC funding is needed to overcome at least three barriers. First, the lack of devices that are optimized for standard DC power is a key barrier to market adoption. Second, the overall energy benefits have not yet been demonstrated over the range of anticipated products. Third, stakeholders have not identified benefits that ZNE can bring to reducing plug loads. An important step in eliminating these barriers is to demonstrate to manufacturers the versatility of DC powering. Some of the prototypes developed for this project are shown in Figure 71. These are being shown to manufacturers for possible commercialization. A complete low-voltage DC network was also created and prototyped (and is illustrated in the Supplemental

Research chapter). A California-based manufacturer is already evaluating it for commercialization.

**Figure 71: Direct Direct Current Prototypes**

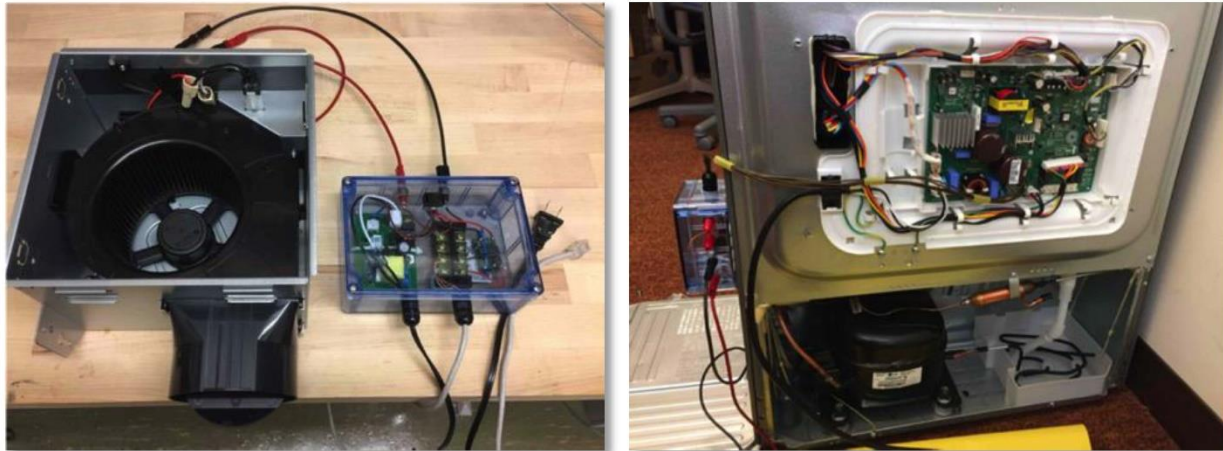

(a) Direct-DC Fan

(b) Direct-DC Refrigerator

Source: Daniel Gerber

For products providing security, safety, or medical services, EPIC funding is especially necessary. First, these manufacturers' products have not been challenged to improve efficiency because they are exempt from standards. (Many manufacturers don't even know how much power their products draw.) Second, dealing with medical equipment requires special attention to safety, so manufacturers stick with proven solutions. Third, solutions often lie "outside the box." For example, smoke alarms could be powered with PoE. Finally, few researchers have studied these devices, so there is not even a good sense of the scale and nature of the problem (and solutions).

## 2. Anticipated Energy Use

As described in Chapter 1, plug loads comprise at least 25 percent of energy use in U.S. buildings (U.S. Department of Energy 2015). The Energy Commission estimates that in 2014, plug loads consumed 28 percent of residential energy use (21.9 GWh) in investor-owned utility (IOU) territories. Energy Commission projections indicate that this will grow by 150 percent in 10 years, reaching 33.3 GWh by 2024 (CEC 2015). In a California study, plug loads were responsible for 40 percent of a commercial building's energy use; continuous energy use—caused mostly by plug loads—exceeded 40 percent in about half the residences in a study of 25,000 homes. In California, electricity demand attributed to plug loads is about 50,000 GWh/year, although estimates differ because definitions of plug loads vary. And the energy used by plug loads is growing, as the number and variety of devices proliferate.

## 3. Energy Savings Resulting From This Research

This research explored three lines of inquiry, as detailed in chapters 2, 3, and 4:

- Reducing standby energy consumption
- Energy-saving opportunities of using direct current in buildings



- Safety, security, and health devices

The energy savings will be achieved in thousands of different types of products and use cases. This complicates the estimation of savings, but not the confidence that savings are possible. Table 27 provides estimates of potential benefits to ratepayers after full implementation, in electricity savings, cost savings, and demand and emissions reductions. The assumptions follow the table.

**Table 27: Project Impacts: Electricity and Cost Savings, Demand and Greenhouse Gas Reduction in California**

	<b>Electricity Savings (GWh/year)</b>	<b>Cost Savings (M\$/year)</b>	<b>Demand Reduction (MW)</b>	<b>GHG Emissions Reduction – CO<sub>2</sub>e (MT/year)</b>
<b>Reducing Standby Energy Consumption</b>				
Zero standby	1,822	309	208	665
Higher mode savings	182	31	21	67
<b>Energy-Saving Opportunities of Using Direct Current in Buildings</b>				
DC networks	1,200	204	140	136
Power supply efficiency savings	1,122	190	128	409
More efficient appliances	557	95	64	203
<b>Safety, Security, and Health Devices</b>				
Builder installed residential	863	147	99	315
Builder installed commercial	154	24	18	56
Medical	121	19	14	44
<b>TOTAL</b>	<b>6,021</b>	<b>1,019</b>	<b>692</b>	<b>1,895</b>

**Assumptions:**

Base case is the number of households or commercial floor area in 2014 plus new construction until 2024.

Task 2 savings are based on the number of products in no-load, low-mode, or controllable by generic sensors, eliminating no load use, assuming 60 percent of the products will have been replaced by 2024.

The Task 3 base case is the number of consumer electronics products operating with power supplies, and efficient appliances are represented by refrigeration products, savings are based on reducing conversion losses, and improved efficiency due to DC operation (ranging from 8 to 10 percent). DC network savings are 200 kWh/home, for 50 percent of homes in California.

The Task 4 base case is from field measurements and savings projected from the most efficient GFCIs available on the market (40 percent); medical energy use is based on plug load surveys in medical buildings and savings assumed to be 60 percent, with 10 percent of products affected by 2024.

Demand reduction was calculated assuming savings occurred at a constant rate.

Insufficient detail on product categories may have caused minor double-counting of energy savings.

Energy savings are valued at \$0.17/kWh for residential and \$0.16/kWh for commercial, and reduced carbon emissions are estimated assuming 0.73 lbs/kWh.

Source: LBNL

In summary, this project will reduce electricity use by about 6,000 GWh/year and will save ratepayers about \$1.02 billion/year. In addition, electrical demand will be reduced by 690 MW, and GHG emissions will be reduced by 1,900 million tons of CO<sub>2</sub>e/year.

The principal California market segments affected by this research will be the residential and commercial sectors. Note that the estimate includes only office buildings within the commercial sector; this is a conservative assumption. The technologies described in this report apply to both new and existing buildings. However, the ZNE technologies principally target new construction. Projected savings are conservative because there are already examples of 50 percent savings for some applications. These assumptions are reasonable given the uncertainty in the definitions of plug loads and the rate at which energy-saving technologies will be taken up by the market. Many plug load devices have relatively short lifetimes—fewer than 10 years—which means that savings resulting from this research will accelerate in a relatively rapid time frame as legacy equipment is retired and replaced with new, more efficient devices. A significant fraction of the potential energy savings can be attained once these strategies are implemented.

#### **4. Secondary Benefits From Energy Savings**

Because of the avoided energy use resulting from this project, a number of secondary benefits accrue to both customers and the grid:

- Customers will receive lower bills, and the net energy cost savings will accumulate.
- Costs associated with building new generation will be delayed or reduced; this will in turn reduce operations, maintenance, and capital costs.
- Savings from plug loads may reduce peak loads in both summer and winter.
- Lower plug load energy consumption may alleviate electric system power flow congestion.

#### **5. Utility and Ratepayer Benefits**

The project will benefit California IOU electricity ratepayers with respect to the EPIC goals in the following ways:

- Greater reliability. Reduced electricity demand by plug loads, achieved by the innovations proposed in this project, will avoid reliance on the least-reliable generation sources at the margin. The project also will improve power factors, which will improve system reliability. There may be additional reliability from reduced peak demand, although the extent of these benefits has not been determined.
- Greater resilience and energy security. As described in the Supplemental Research chapter, during power outages a low-voltage DC network could provide electricity to maintain key services, such as medical devices, lighting, and communications. During normal conditions, a home DC network would save grid electricity by directly powering some appliances and avoiding as much as 300 kWh/year of grid-supplied electricity.
- Lower costs. Less energy consumed by plug loads translates into lower utility bills, both in terms of reduced kWh and kW. These savings will be, to some extent, offset by increased costs of products, although in the case of DC-powered devices, components

are removed from the device, thus potentially leading to lower costs. For life-safety devices, it was shown that GFCI power consumption could be reduced by 80 percent. However, the innovations proposed in this project will provide new features beyond only saving energy, so any incremental costs will be spread among these features.

- Increased safety. Consumers are safer when more devices can be switched to locally generated power during grid outages. This is especially true for consumers relying on critical medical devices. The low-voltage DC power envisioned for more products also reduces public exposure to hazards from electrical shocks. Connecting garage door openers to a DC network ensures that can be opened during power outages, potentially saving lives.
- New technologies. One immediate barrier to DC adoption is the lack of DC-compatible devices. This project created new devices and demonstrated the feasibility and versatility of DC powering to manufacturers. These products can now be included in demonstration projects where the overall energy benefits of DC power can be quantified for consumers, manufacturers, and other stakeholders.
- Benefits to the grid. This research will have only modest impacts on the grid because many plug loads operate continuously or not particularly at peak. However, battery-reliant plug loads can be recharged on DC circuits using stored solar energy or discharged into dual-power appliances during peak hours. This will introduce an opportunity to shift some system load.

## 6. Cost/Benefit Ratios

The anticipated benefits and costs of the project are summarized in Table 28. The benefits are (conservatively) based on five years of accumulated savings. Costs were calculated only for the residential sector because it makes up almost 90 percent of plug load energy use. Each California household has 50 eligible devices, or 700 million devices in all households. If the incremental cost is \$0.50/device, then the residential costs are \$0.35 billion.

**Table 28: Anticipated Benefits and Costs**

<b>Perspective</b>	<b>CEC/EPIC Perspective</b>	<b>Consumer</b>
Benefit	\$4.3 billion	\$4.3 billion
Cost	\$1.6 million	\$0.35 billion
Benefit/Cost Ratio	~2,700	~12

Source: LBNL

The benefits from the consumer’s perspective may ultimately be much higher because they pay this incremental cost to obtain other features. Consumer costs do not include savings from avoided investments in PV or other renewable technologies to meet ZNE targets.



# CHAPTER 8:

## Technology/Knowledge Transfer

---

### 1. Target Audience

The project has a diverse audience for technology transfer. Some of the key audiences are: consumers, manufacturers, researchers, and policy makers. The project team’s technology transfer activities and target audiences are described in Table 29.

**Table 29: Target Audiences**

Audience	Target Message and Activity
Manufacturers of plug load devices, power supplies, DC power, and life safety products	The goal was to disseminate research results and create prototype demonstrations of zero-standby technology power supplies and devices and direct DC devices. This was accomplished through collaborations and discussions with project partners and individual manufacturers. California-based manufacturers include Belkin, Power Integrations, and Delta. One member of the project team is on IEC 62301, the technical standard covering measurement of standby power.
Codes and Standards authorities	The goal was to identify product-level standards, test procedures, and enhancements to building codes that need to be created or updated. Team members met with staff from the Energy Commission standards office, EPA ENERGY STAR, and the DOE Buildings Technology Office.
Utilities	The goal was to convey relevant research results for absorption into efficiency and incentive programs. This occurred through multiple face-to-face conversations and presentations with staff from most California utilities. One California utility has agreed to fund follow-on investigations of builder-installed loads.
Policymakers	The goal was to inform policymakers of key issues related to plug loads and possible solutions. This was accomplished through presentations at large international conferences on energy efficiency in the United States and Europe.
Consumers and Customers, both existing and potential	The goal was to expand awareness of the energy consumption of plug loads and efficiency opportunities through demonstrations of devices and through publications in consumer-facing magazines, websites, etc. For example, articles were published in <i>Home Energy Magazine</i> .

Source: LBNL

## 2. Publications and Presentations

At the time this report was prepared, at least 14 articles had already been published and at least four presentations had been made. Table 30 shows a list of publications and presentations. Note that most conference papers were accompanied by a presentation, but these were not listed.

### Publications

- Fares, Robert, Marina Sofos, Jared Langevin, Robert Hosbach, Alan Meier, Joshua Butzbaugh, and Paul Ehrlich. 2018. "Improving Characterization of Miscellaneous Energy Loads in Energy Demand Models." In *Proceedings of the ACEEE 2018 Summer Study on Energy Efficiency in Buildings*. Pacific Grove, Calif.: American Council for An Energy Efficient Economy (Washington, D.C.).
- Gerber, Daniel, Alan Meier, Robert Hosbach, Richard Liou, Daniel L. Gerber, Alan Meier, Robert Hosbach, and Richard Liou. 2018. "Zero Standby Solutions with Optical Energy Harvesting from a Laser Pointer." *Electronics* 7 (11): 292. <https://doi.org/10.3390/electronics7110292>.
- Gerber, Daniel, Robert Hosbach, and Alan Meier. 2018. "Zero Standby Power Solutions." In *Proceedings of the ACEEE 2018 Summer Study on Energy Efficiency in Buildings*. Pacific Grove, California: American Council for An Energy Efficient Economy (Washington, D.C.).
- Koyanagi, Hidemitsu, and Alan Meier. 2017. "Validity of Energy Simulations and Energy Measurements in a Net Zero Energy Office Building: A Case Study." *ASHRAE Conference Paper* LB-17-C032 (June).
- Koyanagi, Hidemitsu, and Alan Meier. 2017. "Case Study on the Validity of Planned Energy Consumption Breakdown and Energy Measuring in Office ZEB in California, U.S." *Architectural Institute of Japan (AIJ)* 23 (54): 557–61. <http://doi.org/10.3130/aijt.23.557>.
- Koyanagi, Hidemitsu, and Alan Meier. 2017. "Validity of Energy Simulations and Energy Measurements in A Net Zero Energy Office Building: A Case Study." In *Architectural Institute of Japan Conference*.
- Meier, Alan K. 2018. "New Standby Power Targets." *Energy Efficiency* June, 1–12. <https://doi.org/10.1007/s12053-018-9677-x>.
- Meier, Alan, and Hans-Paul Siderius. 2017. "Should the next Standby Power Target Be 0-Watt?" In *Eceee 2017 Summer Study – Consumption, Efficiency & Limits*. Presqu'île de Giens, Hyeres, France: European Council for an Energy-Efficient Economy.
- Meier, Alan, Leo Rainer, and Aditya Khandekar. 2018. "Builder-Installed Electrical Loads: Parts of the House That Stay On and On." *Home Energy Magazine* Fall 2018.
- Meier, Alan. 2018. "Climate Change, Garage Door Openers, and Home Energy." Column. eceee website. <https://www.eceee.org/all-news/columns/climate-change-garage-door-openers-and-home-energy/>.
- Meier, Alan. 2018. "When Appliances Use No Energy and Self-Disassemble When They Retire." eceee Columns (blog). February 27, 2018. <https://www.eceee.org/all-news/columns/when-appliances-use-no-energy-and-self-disassemble-when-they-retire/>.

- Meier, Alan. 2018. "Zero Standby Solutions." Poster presented at the 2018 EPIC Symposium: Accelerating Clean Energy Innovation, Sacramento, California, February 7.
- Meier, Alan. 2018. "Zero Standby Solutions." Poster presented at the Building Technologies Office Peer Review, Crystal City, Virginia, April 30.
- Rainer, Leo, Aditya Khandekar, and Alan Meier. 2018. "Builder Installed Electric Loads: The Energy Mortgage on a New House." In *Proceedings of the ACEEE 2018 Summer Study on Energy Efficiency in Buildings*. Pacific Grove, California: American Council for An Energy Efficient Economy (Washington, D.C.).

## **Presentations**

- Fares, Robert, and Alan Meier. 2018. "Introduction to Miscellaneous Energy Loads (MELs) and BTO's MELs Characterization Efforts." Presented at the Building Technologies Office Peer Review, Crystal City, Virginia, May 1.
- Meier, Alan. 2017. "Cloud-Enabled Energy Efficiency—an Opportunity or a Threat?" Invited Lecture, Canon Institute, Tokyo, September 4.
- Meier, Alan. 2017. "Delivering Energy Services Through the Web: California's Experiences." In *Reframing Urban Energy Policy—Challenges and Opportunities in the City of Seoul*. Seoul, Korea: Seoul Metropolitan Government.
- Meier, Alan. 2017. "ZNE Ready Plug Loads." Presented at the EPIC Plug Load Collaborative Meeting, Sacramento, California, September 27.

# CHAPTER 9:

## Conclusions and Future Work

---

### 1. Conclusions

The goal of this project was to develop technologies that will reduce the energy use of plug loads (which are also called miscellaneous electrical loads—MELs). Lower energy use by this category will reduce building electricity use, carbon emissions, and consumer costs. When these products achieve very-low-energy use, consumers will be able to more economically tap into renewable energy sources and achieve greater energy security from energy interruptions.

The scope of discussions in this report demonstrates that no single technology can reduce plug load energy use because it is so diverse. Furthermore, limited resources prevented intensive studies of all major devices; instead the project focused on areas where the research team felt significant innovations were possible. In addition, some technical solutions apply to families of products. The approach adopted in this project was therefore multi-pronged and consisted of three steps to:

- Identify plug loads and evaluate current technologies.
- Develop lower-energy alternatives.
- Commercialize solutions.

Activity was undertaken in all steps. However, the diversity of plug loads means that, for some devices, only the first step was accomplished. In others, however, commercialization is already underway. Deploying new technologies is as important as developing them in the first place. For that reason, this report also considered the codes, standards, and other policies that affect the energy use of plug loads.

The conclusions are organized by chapter, followed by overall conclusions.

### 2. Zero-Standby Solutions

Improvements to power supplies have drastically reduced standby consumption over the last 20 years. However, the need for standby-power reduction persists due to the increasing population of devices with standby modes and the proliferation of IoT devices. Since modern electronics are diverse in application and requirements, the strategy of this project was to create a portfolio of solutions to tackle standby consumption. Several such solutions were presented and prototyped. Each solution in this particular report used a sleep transistor, which is a solid-state standby-killer switch that can connect or disconnect the main device from its power supply.

The first solution demonstrates the value of burst mode for lightly loaded converters. This work developed a stand-alone controller that could enhance any converter with burst mode. Essentially, it disables the converter for one to two seconds, and reactivates the converter when the output voltage falls below a certain voltage.

The second and third solutions use optical energy harvesting, with an intended application in remote line-of-sight devices such as DVD VCRs, lights, fans, and curtains. One of these optical

techniques uses IR energy harvesting to activate a footer switch and wake the device. However, the prototype had limited activation range due to the wide beam angle of the IR LED. This limitation could not be overcome, so another optical technique was developed, where the receiver instead harvests visible light energy from a laser pointer. The laser prototype was demonstrated to activate a device at a range of 25 m. However, its drawbacks are in the accuracy required to hit an individual photodiode with a laser pointer.

The fourth solution uses a wake-up radio to activate a sleep transistor. The wake-up radio is an ultra-low-power microwatt receiver whose sole purpose is to wake the device. It is often capable of being programmed and addressable. The prototype used the AS3932 125 kHz wake-up radio. Its range is limited to 3 m due to its use of low-frequency magnetically coupled wireless communication. Nonetheless, it demonstrates the principle of using a wake-up radio in conjunction with burst mode and a sleep transistor. Other techniques in literature have demonstrated the AS3932 at a range of 50 m.

This work demonstrates zero or near-zero standby power as being technically feasible in several families of products. These solutions have both advantages and drawbacks and will require further technical improvements and reductions in cost before they can be commercialized. In addition, the portfolio of solutions will need to be broadened before standby power use can be confidently—and economically—eliminated. There is reason to be optimistic, however, since many of the technologies investigated here barely existed a decade ago.

### **3. Direct Current Power**

Buildings with DC power have attracted considerable attention recently, but the development of highly efficient DC-ready loads has lagged (with the exception of mobile electronics). This work categorized the types of loads whose efficiency directly benefits from a DC input. DC-connected loads can be designed to connect directly to DC distribution, thus providing the most benefit in efficiency and cost. Examples include variable speed motor loads (HVAC, refrigeration, water heating) and wireless loads. DC-converted loads require a DC-DC converter front end, which is usually an improvement in efficiency and cost over equivalent AC-DC converters. Examples include LED lighting and computers. Finally, DC-indifferent loads such as resistive heating elements or outdated fixed speed motors benefit equally from DC or AC distribution.

Several types of loads were studied, and several were modified or prototyped as direct-DC. These loads include a wall adapter, bath fan, refrigerator, task lamp, and zone lighting rig. The main focus of each design is to leverage DC input to eliminate or improve the efficiency of the conversion stages.

This project obtained new insights during the design, development, and measurement phases. These insights were specific to the categories examined, namely, electronics, motor loads, and lighting. In electronics, DC input can allow for the downsizing or elimination of wall adapters. The efficiency benefits generally favor DC, though the comparisons must be made with careful attention to the distribution voltage and conversion process. In motor loads, the most efficient type of BLDC motor is designed such that its internal DC capacitor bus naturally operates at the DC input voltage. Although there is very little loss across a diode bridge rectifier, a PFC

boost rectifier is notably less efficient. In lighting, task lamps that connect to a DC charging station with programmable power supply capability can use the charging station as the LED driver. Zone lighting can benefit greatly from series remote drivers, but further research must validate their feasibility. In all loads, DC input can allow for a great reduction in the size of the DC capacitors and will also improve power quality. Further study is required to determine the full value of these secondary effects.

#### **4. Safety, Security, and Health Devices**

This investigation identified a unique category of energy-using devices that provide life-safety, health, and security to buildings. Their installation or use is dictated by building codes, health providers, insurance companies, and other entities. None of these entities would ordinarily consider energy efficiency as a priority feature.

While not particularly large today, SSHD energy use will steadily climb as existing buildings begin to comply with new codes and new types of SSHDs appear. Also, these estimates understate their total contribution because devices from other categories are now appearing or shifting from elective products into SSHDs (such as modems, WiFi routers, FiOs boxes, and batteries for garage door openers). This growth helps explain why MELs are projected to grow faster than any other end use.

There are diverse strategies to reduce future SSHD energy consumption (or at lessen growth rates). For some devices, such as GFCIs and mechanical ventilation systems, the best-on-market models consume less than half as much power as typical models. It appears that efficiencies of medical equipment could be greatly improved through better compressors and controls. Battery-charging systems for a host of devices can also be made more efficient. Completely new solutions, possibly relying on customized ICs, could also offer energy savings.

At the same time, reducing the energy consumption of SSHDs is challenging. Most SSHDs consume little energy and therefore offer correspondingly small energy savings, even when reductions of 50 percent are technically feasible. The efficiency improvements may still pay for themselves in reduced operating costs, but even though they will pay for themselves, consumers, contractors and others will not spend time or money implementing the changes because the payoff is so small. Few people will devote an hour searching for an SSHD that uses 5 kWh/year—about \$1—less electricity.

However, the case for improved efficiency of GFCIs is much stronger. Efficiency does not appear to cost more. The average power use of a sample of U.S. GFCIs was 1.67 W. One model, however, drew just over 0.25 W. Two models produced by the same Chinese manufacturer had similar costs, but one draws over eight times more power than the other. And the Japanese models drew even less power: an average of less than 0.20 W, with one model drawing only 0.09 W (5 percent of the U.S. average).

A second obstacle is that higher priorities determine the performance and characteristics of many SSHDs. These range from safety—electrical and fire—to health. Energy impacts rarely enter into the policymaking decisions for these devices (or, if they do, it is to exempt the devices). A coordinating council might help by raising the profile of energy use in these devices.

An important element of this investigation involved careful measurement, inspection, and teardown of SSHCs. With this information, it was hoped to first identify how these devices actually used energy and then propose lower-energy solutions. Unfortunately, these devices were more resistant to teardowns and detailed measurements than expected. As a result, fewer savings opportunities were identified than anticipated.

## **5. Test Methods**

Test methods, codes, and standards do not yet capture the unique features of plug loads with zero or very-low-standby power. Those unique features span energy consumption behavior, materials, and health and safety. Establishing test methods and standards is especially challenging because each product has a small environmental footprint—drawing less than a few watts of power and consisting of only a few grams of materials—but the cumulative impact of billions of these products is enormous.

For nearly all energy test methods, the boundaries of measurement need to be reconsidered to reflect new behaviors of the technologies. The boundaries include upstream-energy use, the environment, and duration of measurement. All test methods and standards need to consider that more and more products will operate for long periods unconnected to the grid. This phenomenon extends beyond today's portable electronics to electric vehicles and vacuum cleaners. The testing dilemma is how to define (and measure) standby modes when "disconnected" may be a common configuration.

Higher-power DC products are appearing in the market, but energy-test procedures have not been updated to reflect this market shift. The ultimate goal should be comparable treatment of AC and DC products.

Future zero-standby solutions may require manufacturers to comply with new health and safety requirements. For example, lasers might be used to enable energy harvesting. Similarly, life cycle assessments of materials associated with low-standby technologies need further investigation. Most studies of energy storage, for example, focus on much larger products.

Fortunately, none of these requirements appear insurmountable.

Health and life-safety devices are presently exempt from most energy standards and codes. Our research suggests that these products' energy consumption is growing.

## **6. Recommended Future Work**

This project covered several, distinct research areas so the recommended future work is necessarily diverse. The goal here is to point to both broad areas and specific projects. The future work described here is not meant to be comprehensive or exhaustive but is rather based on the findings from this project. The future work is roughly divided by the tasks in the project. However, not everything falls neatly into these groups and some material spans more than one task. The reader should refer to specific chapters to better understand the context of project recommendations.

## **Zero-Standby Solutions**

No single technology will eliminate standby-power use. However, several technologies appear promising for specific applications or use cases. To advance them toward commercial development and incorporation, the following future work is recommended:

- Optimize wake-up radio, possibly including integration with the router. In addition, industry should consider burst mode for powering wake-up radios.
- Develop a scheduling algorithm in the router for devices to perform intermittent updates or data transfers.
- Explore more DC alternatives such as a power server that can be controlled to limit current or turn off devices in standby.
- Investigate energy harvesting and storage combinations optimized for specific use cases.
- Explore lifetime batteries for certain devices.
- Recommend industry to develop and popularize burst mode. This includes enabling pins on converter packages and designing burst mode controllers that can grant burst mode capability to normal converters.
- Design networks with occupancy sensors that can enable devices to shift themselves into lower-power modes.

In the long run, coordinated improvements in efficiency, energy harvesting, and energy storage will be the best strategy to achieving zero-standby-power use.

## **Direct Current Devices**

This project demonstrated the potential for DC networks in providing energy savings, safety, and resiliency. Further research should recognize the multiple benefits of DC power (rather than simply focusing on energy savings). For this reason, many of the recommendations here focus on the robust integration of products rather than the products themselves. Future work might include the following activities:

- Perform detailed loss analysis of AC boost converters to determine losses in PFC boost AC/DC converters.
- Develop integrated DC networks of high-priority communications and safety devices, supported by storage and stand-alone PV.
- Improve DC network power distribution management and data (including energy price) exchange and define a standard mechanism for 380-V DC.
- Integrate important safety and security devices into a DC network, such as sump pumps and garage door openers.
- Standardize communication protocols for managing power distribution and key application layer protocols for safety and critical load devices.
- Develop energy and performance test procedures for DC devices.
- Work with manufacturers to develop dual-powered AC-DC devices.



- Work with appliance-industry partners to develop high-power 380 V DC "behind the wall" loads such as HVAC, refrigeration, EV charging, hot water, and washers and dryers.
- Work with solar industry partners to allow a 380-V DC bus to connect power optimizers, storage, and loads.
- Assess the relative efficiency of "direct PV" devices for sale today that power an end-use device directly from a PV panel, possibly with a battery included (such as, air conditioners).
- Improve a prototype of a series remote driver and get it evaluated by industry.

## **Safety, Security, and Health Devices**

A sustained research effort should be undertaken to improve the energy efficiency of devices where health or safety considerations hobble innovation. This research needs to be carefully linked to the health and safety communities to understand the service needs, identify technical solutions, and field-test prototypes. The first three targets should be oxygen concentrators, mechanical ventilation systems, and CPAPs.

The most efficient GFCI measured drew only 5 percent of the power of the average GFCI used today. There appears to be no relationship between the cost of a GFCI and its efficiency. Guidelines or standards should be explored.

For smoke and CO alarms, research should be undertaken to prevent the need for a power supply. This could be accomplished through a "10-year" battery, possibly combined with energy harvesting. This solution will require changing building codes but might reduce overall costs if wiring costs can be eliminated.

Some safety devices, notably garage door openers, may benefit from connection to a new DC network. These networks offer other important benefits such as resiliency to power outages and reduced environmental burdens caused by battery replacements.

Most SSHDs consume little energy and therefore offer correspondingly small energy savings, even when reductions of 50 percent are technically feasible. The efficiency improvements may still pay for themselves in reduced operating costs, but even though they will pay for themselves, consumers, contractors and others will not spend time or money implementing the changes because the payoff is so small. Government, utilities, and other entities need to design programs that require little or no additional effort on the part of consumers, contractors, and other decision makers to shift from current products to the most efficient available. California (and other entities) faces an administrative problem related to SSHDs.

The problem is different for mechanical ventilation systems because occupants switch off the systems and expose themselves to poor indoor air quality to avoid thermal discomfort and noise. Here the goal is to increase ventilation, which leads to higher electricity consumption. More precisely, the goal is to convince occupants to take other measures to reduce their exposure to indoor air pollutants. Some of this research crosses into social science and public policy.

## **Codes and Standards**

The evolution of plug loads will no doubt continue, possibly at faster rates than ever. Test methods, codes, and standards need to be continuously updated to provide a transparent framework for evaluation by manufacturers, policy makers, and consumers.

Over the long run, it will be necessary to develop consistent energy-bookkeeping procedures that reflect network-related energy consumption from a product. Devices may not be using grid power for operation, but they may be increasing upstream-energy use from their high communications/data/cloud processing loads. In other words, when a product either transmits or receives a byte of data in the course of controlling its operation, how much additional energy consumption is induced in the local network and in the cloud?

In the near term, the method for testing low-power modes, IEC 62301, may require entirely new sections describing procedures to measure behavior of devices with energy harvesting and storage. Greatly extending the measurement interval to capture harvesting and storage/discharge behavior will probably not be sufficient. IEC 62301 should also be extended to define measurement methods that characterize unplugged behavior. These modifications will require research in addition to administrative updates.

## LIST OF ACRONYMS AND GLOSSARY

Term	Definition
AC	Alternating Current
AFCI	Arc Fault Circuit Interrupters
API	Application Programming Interface
ASCII	American Standard Code for Information Interchange
BLDC	Brushless DC
BLE	Bluetooth Low Energy
Burst Mode	Control that bursts operation of a power converter to handle low load
Cascode	A set of stacked transistors, whose purpose varies with application
CEC	California Energy Commission
CO	Carbon Monoxide
CPAP	Continuous Positive Airway Pressure
DC	Direct Current
DC-connected	Direct-DC load whose internal DC stage can directly connect to the distribution
DC-converted	Direct-DC load that requires a DC/DC converter to interface with the distribution
DC-indifferent	Direct-DC load that does not benefit from DC distribution
Direct-DC	Internally DC load with a DC input
DOE	U.S. Department of Energy
EMAN	Energy Management
EMI	Electromagnetic Interference
EPIC	The Electric Program Investment Charge, created by the California Public Utilities Commission in December 2011, supports investments in clean energy technologies that benefit electricity ratepayers of Pacific Gas and Electric Company, Southern California Edison Company, and San Diego Gas & Electric Company.
EPRI	Electric Power Research Institute
EVSE	Electric Vehicle Supply Equipment
GFCI	Ground Fault Circuit Interrupts
GWh	Gigawatt-hour

<b>Term</b>	<b>Definition</b>
Hz	Hertz
IC	Integrated Circuit
IoT	Internet of Things
IOU	Investor-Owned Utility
IP	Internet Protocol
IR	Infrared
kHz	Kilohertz
LBNL	Lawrence Berkeley National Laboratory
LED	Light-Emitting Diode
MELs	Miscellaneous Electrical Loads
MHz	Megahertz
MOSFET	Metal-oxide semiconductor field-effect transistor. A transistor that switches on (closed) if a voltage is applied at the gate.
mW	Milliwatt
Native-DC	Internally DC load with an AC input
NMOS (N-type)	MOSFET with N-type doping. Turns on with a positive gate voltage
OSHA	Occupational Safety and Health Administration
PFC	Power Factor Correction
PMOS (P-type)	MOSFET with P-type doping. Turns on with a negative gate voltage
PoE	Power over Ethernet
PPS	Programmable Power Supply
PV	Photovoltaic
QC	Quick charge
RF	Radio frequency
Smart Grid	An electricity supply network that uses digital communications technology to detect and react to local changes in usage
SSHD	Safety, Security, and Health Device
USB	Universal Serial Bus

<b>Term</b>	<b>Definition</b>
USB-PD	USB Power Delivery
V	Volt
VFD	Variable Frequency Drive
WuR	Wake-up Radio
ZNE	Zero Net Energy

## REFERENCES

- 1000bulbs.com. 2014. *Understanding LED Drivers*. <https://www.1000bulbs.com/pdf/understanding-led-drivers.pdf>
- ALee, G., and W. Tschudi. 2012. "Edison Redux: 380 Vdc Brings Reliability and Efficiency to Sustainable Data Centers." *IEEE Power and Energy Magazine* 10 (6): 50–59. <https://doi.org/10.1109/MPE.2012.2212607>
- Aslan, Joshua, Kieren Mayers, Jonathan G. Koomey, and Chris France. 2017. "Electricity Intensity of Internet Data Transmission: Untangling the Estimates: Electricity Intensity of Data Transmission." *Journal of Industrial Ecology* 27 (August): 2391.
- Backhaus, Scott, Gregory W. Swift, Spyridon Chatzivasileiadis, William Tschudi, Steven Glover, Michael Starke, Jianhui Wang, Meng Yue, and Donald Hammerstrom. 2015. "DC Microgrids Scoping Study Estimate of Technical and Economic Benefits." LA-UR-15-22097. Los Alamos National Laboratory. [http://www.energy.gov/sites/prod/files/2015/03/f20/DC\\_Microgrid\\_Scoping\\_Study\\_LosAlamos-Mar2015.pdf](http://www.energy.gov/sites/prod/files/2015/03/f20/DC_Microgrid_Scoping_Study_LosAlamos-Mar2015.pdf)
- Baez, C., B. Fischel, B. Chrisman, and J. Babula. 2016 *Appliance Efficiency Regulations*. California Energy Commission. <http://www.energy.ca.gov/2017publications/CEC-400-2017-002/CEC-400-2017-002.pdf>
- Becker, Dustin J., and B. J. Sonnenberg. 2011. "DC Microgrids in Buildings and Data Centers." In *2011 IEEE 33rd International Telecommunications Energy Conference (IN<sup>TELE</sup>EC)*, 1–7. IEEE.
- Berman, R. 2009. *Understanding Ground Fault and Leakage Current Protection*. Underwriters Laboratories. <https://www.ul.com/global/documents/corporate/aboutul/publications/newsletters/electricalconnections/january09.pdf>
- Boeke, U., and M. Wendt. 2015. "DC Power Grids for Buildings." In *2015 IEEE First International Conference on DC Microgrids (ICDCM)*, 210–214. <https://doi.org/10.1109/ICDCM.2015.7152040>
- Bollmann, Klaus, and Tom C Penick. 2013. LED Lighting System with Bypass Circuit for Failed LED.
- Borgeson, Samuel. 2013. Targeted Efficiency: Using Customer Meter Data to Improve Efficiency Program Outcomes. Ph.D. Dissertation, Berkeley, California: University of California.
- BS 7671:2008. 2015. "Requirements for Electrical Installations. IET Wiring Regulations." Standard. Stevenage, England: Institution of Engineering and Technology.
- California Air Resources Board. 2014. "First Update to the Climate Change Scoping Plan." Sacramento: California Environmental Protection Agency.

- California Energy Commission. January 2017. "2016 Appliance Efficiency Regulations." CEC-400-2017-002. <http://www.energy.ca.gov/2017publications/CEC-400-2017-002/CEC-400-2017-002.pdf>
- California Energy Commission. No date. Electricity Consumption by County. Online <http://www.ecdms.energy.ca.gov/elecbycounty.aspx>
- California Energy Commission. 2015. "Grant Funding Opportunity - Developing a Portfolio of Advanced Efficiency Solutions: Plug Load Technologies and Approaches for Buildings - Phase II; Attachment 12."
- California Energy Commission. 2008. Low-Power Mode Energy Consumption in California Homes. CEC-500-2008-035. September. <http://www.energy.ca.gov/2008publications/CEC-500-2008-035/CEC-500-2008-035.PDF>
- Chao, Bob, and Linden Harrison. 2008. "Re-Designing Normally-on Load Switches with Zero-Power MOSFETs Reduces Power Consumption." Advanced Linear Devices.
- Chauhan, Rajeev Kumar, C. Phurailatpam, B. S. Rajpurohit, F. M. Gonzalez-Longatt, and S. N. Singh. 2017. "Demand-Side Management System for Autonomous DC Microgrid for Building." *Technology and Economics of Smart Grids and Sustainable Energy 2* (1): 4.
- Chen, Wu, and S. Y. Ron Hui. 2012. "Elimination of an Electrolytic Capacitor in AC/DC Light-Emitting Diode (LED) Driver with High Input Power Factor and Constant Output Current." *IEEE Transactions on Power Electronics* 27 (3): 1598–1607.
- Clement, Kristien, Ief Pardon, and Johan Driesen. 2007. "Standby Power Consumption in Belgium." In *9th International Conference on Electrical Power Quality and Utilisation, 2007. EPQU 2007*, 1–4. IEEE.
- Comstock, O., and K. Jarzomski. 2012. "Consumption and Saturation Trends of Residential Miscellaneous End-Use Loads." In *Proc. 2012 ACEEE Summer Study Energy Efficiency Buildings*.
- CUI Inc. No date. Efficiency Standards for External Power Supplies.
- Das, Dwijasish, N. Kumaresan, V. Nayanar, K. Navin Sam, and N. Ammasai Gounden. 2016. "Development of BLDC Motor-Based Elevator System Suitable for Dc Microgrid." *IEEE/ASME Transactions on Mechatronics* 21 (3): 1552–1560.
- De Almeida, Anibal T., Carlos Patrao, Philippe Riviere, David Da Silva, Barbara Schlomann, Michaela Gigli, and Bob Harrison. 2011. "Standby and Off-Mode Power Demand of New Appliances in the Market." In *6th International Conference on Energy Efficiency in Domestic Appliances and Lighting (EEDAL'11), Copenhagen: Denmark*, 12 p.
- Deconinck, Vincent. No date. Turning a Quick Charge 3.0 Charger into a Variable Voltage Power Supply.

- Delforge, Pierre, Lisa Schmidt, and Steve Schmidt. 2015. "Home Idle Load: Devices Wasting Huge Amounts of Electricity When Not in Active Use." NRDC Issue Paper IP:15-03-A. San Francisco: Natural Resources Defense Council. <https://www.nrdc.org/sites/default/files/home-idle-load-IP.pdf>
- Demirkol, Ilker, Cem Ersoy, and Ertan Onur. 2009. "Wake-up Receivers for Wireless Sensor Networks: Benefits and Challenges." *IEEE Wireless Communications* 16 (4).
- Denkenberger, Dave, Debbie Driscoll, Erica Lighthiser, Peter May-Ostendorp, Brendan Trimboli, and Philip Walters. 2012. "DC Distribution Market, Benefits, and Opportunities in Residential and Commercial Buildings." Pacific Gas & Electric Company. [http://www.xergyconsulting.com/wp-content/uploads/2013/09/Dc-Distrib\\_Final-Report\\_FINAL\\_30Oct2012.pdf](http://www.xergyconsulting.com/wp-content/uploads/2013/09/Dc-Distrib_Final-Report_FINAL_30Oct2012.pdf)
- Didden, Marcel, Jean-Marie De Hoe, Jean Callebaut, and Emmanuel De Jaeger. 2005. "Installing Variable Speed Drives: Energy Efficiency Profits versus Power Quality Losses." In *18th International Conference and Exhibition on Electricity Distribution, 2005. CIRED 2005*, 1–5. IET.
- Dodd. 2018. *Automatic Garage Door Openers: Backup Batteries. California SB-969*. [https://leginfo.legislature.ca.gov/faces/billTextClient.xhtml?bill\\_id=201720180SB969](https://leginfo.legislature.ca.gov/faces/billTextClient.xhtml?bill_id=201720180SB969)
- Eaton Corporation. 2010. White Paper AP08324002E: Evaluating Efficiency and Losses of Various Circuit Protective Devices. [http://www.eaton.com/ecm/groups/public/@pub/@eaton/@corp/documents/content/pct\\_1559746.pdf](http://www.eaton.com/ecm/groups/public/@pub/@eaton/@corp/documents/content/pct_1559746.pdf)
- Ellis, Mark, Hans-Paul Siderius, and Kevin Lane. 2015. "Closing the Gap Towards Net Zero Energy Appliances." In *ECEEE 2015 Summer Study Proceedings*. Vol. 1-038–15. Hyères, France: European Council for an Energy-Efficient Economy. <http://proceedings.ecee.org/visabstrakt.php?event=5&doc=1-038-15>
- Emerge Alliance. 2013. 380 Vdc Architectures for the Modern Data Center. San Ramon, California.
- Engelen, K., E. Leung Shun, P. Vermeyen, I. Pardon, R. D'hulst, J. Driesen, and R. Belmans. 2006. "The Feasibility of Small-Scale Residential DC Distribution Systems." In *IECON 2006 - 32nd Annual Conference on IEEE Industrial Electronics*, 2618–23. <https://doi.org/10.1109/IECON.2006.347246>
- EPIC. 2015. "EPIC Grant Funding Opportunity GFO-15-310: References for Calculating Energy End-Use, Electricity Demand and GHG Emissions-Attachment 12." California Energy Commission.
- European Commission. 2009. Ecodesign Requirements for No-Load Condition Electric Power Consumption and Average Active Efficiency of External Power Supplies. Commission Regulation. Vol. 278/2009. <http://data.europa.eu/eli/reg/2009/278/oj>



- Fallah, Farzan, and Massoud Pedram. 2005. "Standby and Active Leakage Current Control and Minimization in CMOS VLSI Circuits." *IEICE Transactions on Electronics* 88 (4): 509–519.
- Frank, Stephen M., and Steffen Rebennack. 2015. "Optimal Design of Mixed AC-DC Distribution Systems for Commercial Buildings: A Nonconvex Generalized Benders Decomposition Approach." *European Journal of Operational Research* 242 (3): 710–29. <https://doi.org/10.1016/j.ejor.2014.10.008>
- Federal Communications Commission. Radio Frequency Safety. 2015. <https://www.fcc.gov/general/radio-frequency-safety-0>
- Fregosi, D., S. Ravula, D. Brhlik, J. Saussele, S. Frank, E. Bonnema, J. Scheib, and E. Wilson. 2015. "A Comparative Study of DC and AC Microgrids in Commercial Buildings across Different Climates and Operating Profiles." In *2015 IEEE First International Conference on DC Microgrids (ICDCM)*, 159–164. <https://doi.org/10.1109/ICDCM.2015.7152031>
- Fukuoka, Kazuki, Noriaki Maeda, Koji Nii, Masaki Fujigaya, Noriaki Sakamoto, Takao Koike, Takahiro Irita, et al. 2013. "Power-Management Features of R-Mobile U2, an Integrated Application Processor and Baseband Processor." *IEEE Micro* 33 (6): 26–36.
- Fukuoka, Kazuki, Ryo Mori, A. Kato, Motoshige Igarashi, Koji Shibutani, T. Yamaki, Shinji Tanaka, et al. 2012. "A 123 $\mu$ W Standby Power Technique with EM-Tolerant 1.8 V/0 NMOS Power Switch in 28nm HKMG Technology." In *Proceedings of the IEEE 2012 Custom Integrated Circuits Conference*, 1–4. IEEE.
- Gamm, Gerd Ulrich, Matthias Sippel, Milos Kostic, and Leonhard M Reindl. 2010. "Low Power Wake-up Receiver for Wireless Sensor Nodes." In *Intelligent Sensors, Sensor Networks and Information Processing (ISSNIP), 2010 Sixth International Conference On*, 121–126. IEEE.
- Garbesi, Karina, Vagelis Vossos, and Hongxia Shen. 2011. "Catalog of DC Appliances and Power Systems." LBNL-5364E. Berkeley, California: Lawrence Berkeley National Laboratory.
- Geary, David E., David P. Mohr, David Owen, Maurizio Salato, and B. J. Sonnenberg. 2013. "380V DC Eco-System Development: Present Status and Future Challenges." In *Proceedings of 2013 35th International Telecommunications Energy Conference 'Smart Power and Efficiency' (IN<sup>TELE</sup>EC)*, 1–6. VDE.
- George, K. 2006. "DC Power Production, Delivery and Utilization: An EPRI White Paper." [http://directpowertech.com/docs/EPRI\\_DCpower\\_WhitePaper\\_June2006FINAL.pdf](http://directpowertech.com/docs/EPRI_DCpower_WhitePaper_June2006FINAL.pdf)
- Gerber, D. L., V. Vossos, W. Feng, A. Khandekar, C. Marnay, and B. Nordman. 2017. "A Simulation Based Comparison of AC and DC Power Distribution Networks in Buildings." In *2017 IEEE Second International Conference on DC Microgrids (ICDCM)*, 588–95. <https://doi.org/10.1109/ICDCM.2017.8001107>

- Gerber, Daniel L., Vagelis Vossos, Wei Feng, Chris Marnay, Bruce Nordman, and Richard Brown. 2018. "A Simulation-Based Efficiency Comparison of AC and DC Power Distribution Networks in Commercial Buildings." *Applied Energy* 210: 1167–87. <https://doi.org/10.1016/j.apenergy.2017.05.179>
- Glasgo, Brock. 2017. Device-Level Data Analytics to Guide Policy. Dissertation. Carnegie Mellon University. <http://repository.cmu.edu/cgi/viewcontent.cgi?article=1935&context=dissertations>
- GTM Research. 2016. "U.S. Energy Storage Monitor: Q4 2016 Executive Summary." GTM Research.
- Gu, Linlin, Xinbo Ruan, Ming Xu, and Kai Yao. 2009. "Means of Eliminating Electrolytic Capacitor in AC/DC Power Supplies for LED Lightings." *IEEE Transactions on Power Electronics* 24 (5): 1399–1408.
- Gundel, Lara, Michael Apte, and Albert Nematollahi. 1998. "Carbon Monoxide Detector Technology Comparison: Responses to Various Gases." LBNL-40556. Berkeley, California: Lawrence Berkeley National Laboratory.
- Hammerstrom, D. J. 2007. "AC Versus DC Distribution Systems. Did We Get It Right?" In *IEEE Power Engineering Society General Meeting, 2007*, 1–5. <https://doi.org/10.1109/PES.2007.386130>
- Harmonic Current Emissions. 2010. "Guidelines to the Standard EN 61000-3-2." *European Power Supply Manufacturers Association*.
- Huh, Dong-young, Young-seok Kim, et al. 2004. "The Improved Burst Mode in the Stand-by Operation of Power Supply." In *Nineteenth Annual IEEE Applied Power Electronics Conference and Exposition, 2004. APEC'04*, 1:426–432. IEEE.
- IEA. 2001. "Things That Go Blip in the Night: Standby Power and How to Limit It." Paris: International Energy Agency.
- IEA. 2014. "More Data, Less Energy : Making Network Standby More Efficient in Billions of Connected Devices."
- International Electrotechnical Commission (IEC). 2011. "IEC 62301 Household Electrical Appliances Measurement of Standby Power." Edition 2:94720–136.
- IEC. 2014. "61000-3-2: 2014 Electromagnetic Compatibility (EMC)-Part 3-2: Limits – Limits for Harmonic Current Emissions (Equipment Input Current  $\leq 16$  A per Phase)." *British Standards Institute*.
- Ito, Y., Y. Zhongqing, and H. Akagi. 2004. "DC Microgrid Based Distribution Power Generation System." In *The 4th International Power Electronics and Motion Control Conference, 2004. IPEMC* 3:1740–1745.

- Jahromi, Mohsen Ghaffarpour, Galina Mirzaeva, Steven D Mitchell, and David Gay. 2014. "DC Power vs AC Power for Mobile Mining Equipment." In *Industry Applications Society Annual Meeting, 2014 IEEE*, 1–8. IEEE.
- Jhunjhunwala, Ashok, Krishna Vasudevan, Prabhjot Kaur, Bhaskar Ramamurthi, Santosh Bitra, Kushant Uppal, et al. 2016. "Energy Efficiency in Lighting: AC vs DC LED Lights." In *Sustainable Green Buildings and Communities (SGBC), International Conference On*, 1–4. IEEE.
- Jiang, Hailin, Malgorzata Marek-Sadowska, and Sani R Nassif. 2005. "Benefits and Costs of Power-Gating Technique." In *2005 IEEE International Conference on Computer Design: VLSI in Computers and Processors, 2005*. ICCD 2005, 559–566. IEEE.
- Johnston, James, John Counsell, Gerry Banks, and Matt John Stewart. 2012. "Beyond Power over Ethernet: The Development of Digital Energy Networks for Buildings." In *CIBSE Technical Symposium 2012-Buildings Systems and Services for the 21st Century*, Session–5.
- Kakigano, H., Y. Miura, and T. Ise. 2010. "Low-Voltage Bipolar-Type DC Microgrid for Super High Quality Distribution." *IEEE Transactions on Power Electronics* 25 (12): 3066–75. <https://doi.org/10.1109/TPEL.2010.2077682>
- Kang, Sungmuk, Kyungjin Park, Seunghwan Shin, Keunsu Chang, and Hoseong Kim. 2011. "Zero Standby Power Remote Control System Using Light Power Transmission." *IEEE Transactions on Consumer Electronics* 57 (4).
- Keeping, Steven. 2012. *High Current, High Brightness LEDs Simplify Power Supply Solutions*. <https://www.digikey.com/en/articles/techzone/2012/feb/high-current-high-brightness-leds-simplify-power-supply-solutions>
- Kim, Bong-Chul, Ki-Bum Park, and Gun-Woo Moon. 2011. "Sawtooth Burst Mode Control with Minimum Peak Current in Stand-by Operation of Power Supply." In *2011 IEEE 8th International Conference on Power Electronics and ECCE Asia (ICPE & ECCE)*. 474–479. IEEE.
- Kim, Sangkil, Rushi Vyas, Jo Bitto, Kyriaki Niotaki, Ana Collado, Apostolos Georgiadis, and Manos M Tentzeris. 2014. "Ambient RF Energy-Harvesting Technologies for Self-Sustainable Standalone Wireless Sensor Platforms." *Proceedings of the IEEE* 102 (11): 1649–1666.
- Koyanagi, Hidemitsu, and Alan Meier. 2017. "Validity of Energy Simulations and Energy Measurements in a Net Zero Energy Office Building: A Case Study." *ASHRAE Conference Paper* LB-17-C032. June.
- Lanzisera, Steven, Stephen Dawson-Haggerty, H. Y. Iris Cheung, Jay Taneja, David Culler, and Richard Brown. 2013. "Methods for Detailed Energy Data Collection of Miscellaneous and Electronic Loads in a Commercial Office Building." *Building and Environment* 65 (July): 170–77. <https://doi.org/10.1016/j.buildenv.2013.03.025>

- Lee, Kyungmin, Changhyeon Sung, Hoyoung Yoon, and Bongkoo Kang. 2013. "Improvement of Power-Conversion Efficiency at Light-Load Using a Variable-Duty Burst Mode." In *Power and Energy Conference at Illinois (PECI), 2013 IEEE*, 142–146. IEEE.
- LG&E. Watt Finders Guide. 2018. [https://lge-ku.com/sites/default/files/documents/watt\\_finders\\_guide.pdf](https://lge-ku.com/sites/default/files/documents/watt_finders_guide.pdf)
- Lin, James C. 2016. "Human Exposure to RF, Microwave, and Millimeter-Wave Electromagnetic Radiation [Health Effects]." *IEEE Microwave Magazine* 17 (6): 32–36.
- Liu, Zifa, and Mengyu Li. 2014. "Research on Energy Efficiency of DC Distribution System." *AASRI Procedia*, 2nd AASRI Conference on Power and Energy Systems (PES2013), 7: 68–74. <https://doi.org/10.1016/j.aasri.2014.05.031>
- Lo, Yu-Kang, Shang-Chin Yen, and Chung-Yi Lin. 2008. "A High-Efficiency AC-to-DC Adaptor with a Low Standby Power Consumption." *IEEE Transactions on Industrial Electronics* 55 (2): 963–965.
- Long, Changbo, and Lei He. 2004. "Distributed Sleep Transistor Network for Power Reduction." *IEEE Transactions on Very Large Scale Integration (VLSI) Systems* 12 (9): 937–946.
- Lucia, Oscar, Igor Cvetkovic, Hector Sarnago, Dushan Boroyevich, Paolo Mattavelli, and Fred C. Lee. 2013. "Design of Home Appliances for a DC-Based Nanogrid System: An Induction Range Study Case." *IEEE Journal of Emerging and Selected Topics in Power Electronics* 1 (4): 315–326.
- Lu, Tai Ken, Chien Ta Yeh, and Wen Chi Chang. 2011. "Measuring the Use of Residential Standby Power in Taiwan." *Energy and Buildings* 43 (12): 3539–47. <https://doi.org/10.1016/j.enbuild.2011.09.019>
- Magno, Michele, Stevan Marinkovic, Bruno Srbinovski, and Emanuel M. Popovici. 2014. "Wake-up Radio Receiver Based Power Minimization Techniques for Wireless Sensor Networks: A Review." *Microelectronics Journal* 45 (12): 1627–1633.
- Makarabbi, Girish, Vinay Gavade, RakeshBabu Panguloori, and PriyaRanjan Mishra. 2014. "Compatibility and Performance Study of Home Appliances in a DC Home Distribution System." In *2014 IEEE International Conference on Power Electronics, Drives and Energy Systems (PEDES)*. 1–6. IEEE.
- Meier, Alan. 2015. "Efficient and ZNE-Ready Plug Loads - A Research Proposal to the California Energy Commission – EPIC – Funded July 2016." Lawrence Berkeley National Laboratory.
- Meier, Alan K. 2018. "New Standby Power Targets." *Energy Efficiency* June. <https://doi.org/10.1007/s12053-018-9677-x>
- Meier, A. and Q. Aillot. 2016. Permanent Electrical Loads in New Homes. Proceedings of the 2016 ACEEE Summer Study on Energy Efficiency in Buildings.

- Meier, Alan, and Hans-Paul Siderius. 2017. "Should the next Standby Power Target Be 0-Watt?" In *Eceee 2017 Summer Study – Consumption, Efficiency & Limits*. Presqu'île de Giens, Hyeres, France: European Council for an Energy-Efficient Economy.
- Mishra, Anukram, K. K. Rajeev, and Vaibhav Garg. 2018. "Assessment of 48 Volts DC for Homes." In *2018 IEEMA Engineer Infinite Conference (ETechNxT)*, 1–6. IEEE.
- Nextek Power Systems. No date. "Fort Belvoir Direct Coupling® DC Microgrid." Nextek Power Systems. <http://www.nextekpower.com/fort-belvoir-direct-coupling-dc-microgrid/> Accessed January 22, 2016.
- Nishi, S. P., W. Zhang, Y. F. Kuo, and G. Sharma. 2015. "Oxygen therapy use in older adults with chronic obstructive pulmonary disease." *PLoS One* 2015;10(3):e0120684. March 18. doi:10.1371/journal.pone.0120684.
- Noritake, M., K. Yuasa, T. Takeda, H. Hoshi, and K. Hirose. 2014. "Demonstrative Research on DC Microgrids for Office Buildings." In *2014 IEEE 36th International Telecommunications Energy Conference (INTEC)*, 1–5. <https://doi.org/10.1109/INTLEC.2014.6972180>
- Noritake, M., K. Yuasa, T. Takeda, K. Shimomachi, R. Hara, H. Kita, and T. Matsumura. 2015. "Experimental Study of a 400 V Class DC Microgrid for Commercial Buildings." In *2015 9th International Conference on Power Electronics and ECCE Asia (ICPE-ECCE Asia)*, 1730–1735. IEEE.
- Oller, Joaquim, Ilker Demirkol, Jordi Casademont, Josep Paradells, Gerd Ulrich Gamm, and Leonhard Reindl. 2013. "Performance Evaluation and Comparative Analysis of Subcarrier Modulation Wake-up Radio Systems for Energy-Efficient Wireless Sensor Networks." *Sensors* 14 (1): 22–51.
- OSHA. 2015. "Guarding Requirements for 50 Volts or More DC." 1910.303(g)(2)(i). Standard. Washington, D.C.: Occupational Safety and Health Administration.
- Osorio, Felipe Gabriel, Ma Xinran, Yuan Liu, Paul Lusina, and Edmond Cretu. 2015. "Sensor Network Using Power-over-Ethernet." In *2015 International Conference and Workshop on Computing and Communication (IEMCON)*, 1–7. IEEE.
- Paajanen, P., T. Kaipia, and J. Partanen. 2009. "DC Supply of Low-Voltage Electricity Appliances in Residential Buildings." In *CIREN 2009 - 20th International Conference and Exhibition on Electricity Distribution - Part 1*, 1–4. <https://doi.org/10.1049/cp.2009.0925>
- Perea, Austin, Cory Honeyman, Shayle Kann, Allison Mond, M. J. Shiao, Shawn Rumery, and Aaron Holm. 2017. "U.S. Solar Market Insight: 2016 Year in Review - Executive Summary." GTM Research & Solar Energy Industries Association. <http://www.seia.org/sites/default/files/Dn4u8Zl5snSMI2016YIR.pdf>

- Petroski, James. 2016. "Power over Ethernet Thermal Analysis with an Engineering Mechanics Approach." In *2016 32nd Thermal Measurement, Modeling & Management Symposium (SEMI-THERM)*, 50–56. IEEE.
- Public/Private Fire Safety Council. 2006. White Paper: Home Smoke Alarms and Other Fire Detection and Alarm Equipment (Technical report).
- Qualcomm. No date. "Quick Charge 3.0 Specs." Standard. <https://www.qualcomm.com/products/quick-charge-3>
- Rani, Pooja, D. Vignesh, Shivshankar Gunaki, and Ashok Jhunjhunwala. 2016. "Design of Converters for Leveraging 48V DC Power Line at Homes/Offices." In *International Conference on Sustainable Green Buildings and Communities (SGBC)*, 1–5. IEEE.
- Rooks, James A., and Alan K. Wallace. 2004. "Energy Efficiency of VSDs." *IEEE Industry Applications Magazine* 10 (3): 57–61.
- Ryu, Myung-Hyo, Ho-Sung Kim, Ju-Won Baek, Heung-Geun Kim, and Jee-Hoon Jung. 2015. "Effective Test Bed of 380-V DC Distribution System Using Isolated Power Converters." *IEEE Transactions on Industrial Electronics* 62 (7): 4525–4536.
- Saaed, T. E., G. Nikolakopoulos, J. E. Jonasson, H. Hedlund. 2013. "A State-of-the-Art Review of Structural Control Systems." *Journal of Vibration and Control* 21 (5): 919–37. <https://doi.org/10.1177/1077546313478294>.
- Saidur, Rahman, Saad Mekhilef, Mian Basharif Ali, A. Safari, and H. A. Mohammed. 2012. "Applications of Variable Speed Drive (VSD) in Electrical Motors Energy Savings." *Renewable and Sustainable Energy Reviews* 16 (1): 543–550.
- Salcone, Michael, and Joe Bond. 2009. "Selecting Film Bus Link Capacitors for High Performance Inverter Applications." In *Electric Machines and Drives Conference, 2009. IEMDC'09. IEEE International*, 1692–1699. IEEE.
- Sannino, A., G. Postiglione, and M. H. J. Bollen. 2003. "Feasibility of a DC Network for Commercial Facilities." *IEEE Transactions on Industry Applications* 39 (5): 1499–1507. <https://doi.org/10.1109/TIA.2003.816517>
- Savage, Paul, Robert R. Nordhaus, and Sean P. Jamieson. 2010. "From Silos to Systems: Issues in Clean Energy and Climate Change: DC Microgrids: Benefits and Barriers." Yale School of Forestry & Environmental Sciences. <http://environment.yale.edu/publication-series/documents/downloads/0-9/05-DC-Microgrids.pdf>
- Security System News. 2009. "Resi Market Saturation?" August 1. <http://www.securitysystemsnews.com/article/resi-market-saturation>
- Shi, Kaijian, and David Howard. 2006. "Challenges in Sleep Transistor Design and Implementation in Low-Power Designs." In *Proceedings of the 43rd Annual Design Automation Conference*, 113–116. ACM.



- SL Power Electronics. No date. Energy Efficiency Requirements by Levels.
- Smith, Lucy, Taofeeq Ibn-Mohammed, S. C. Lenny Koh, and Ian M. Reaney. 2018. "Life Cycle Assessment and Environmental Profile Evaluations of High Volumetric Efficiency Capacitors." *Applied Energy* 220: 496–513.
- Solly, D. 2007. *Driving High Intensity LED Strings in DC to DC Applications*. [https://www.onsemi.com/site/pdf/Driving\\_High\\_Intensity\\_LEDs.pdf](https://www.onsemi.com/site/pdf/Driving_High_Intensity_LEDs.pdf)
- Starke, M. R., L. M. Tolbert, and B. Ozpineci. 2008. "AC vs. DC Distribution: A Loss Comparison." In *Transmission and Distribution Conference and Exposition, 2008. T #x00026;D. IEEE/PES*, 1–7. <https://doi.org/10.1109/TDC.2008.4517256>
- State of California. 2010. [http://www.leginfo.ca.gov/pub/09-10/bill/sen/sb\\_0151-0200/sb\\_183\\_bill\\_20100507\\_chaptered.pdf](http://www.leginfo.ca.gov/pub/09-10/bill/sen/sb_0151-0200/sb_183_bill_20100507_chaptered.pdf)
- Stippich, Alexander, Alexander Sewergin, Georges Engelmann, Jan Gottschlich, Markus Neubert, Christoph van der Broeck, Philipp Schuelting, Rafael Goldbeck, and Rik De Doncker. 2017. "From AC to DC: Benefits in Household Appliances." In *Proceedings of International ETG Congress 2017*, 1–6. VDE.
- Thomas, Brinda A., Inês L. Azevedo, and Granger Morgan. 2012. "Edison Revisited: Should We Use DC Circuits for Lighting in Commercial Buildings?" *Energy Policy* 45 (June): 399–411. <https://doi.org/10.1016/j.enpol.2012.02.048>
- Tuite, D. 2007. "Arc-detecting circuit breakers will see wider use." *Electronic Design* June. [http://www.afcisafety.org/files/Arc-detecting%20circuit%20breakers%20will%20see%20wider%20use\\_Electronic%20Design\\_06.07.07.pdf](http://www.afcisafety.org/files/Arc-detecting%20circuit%20breakers%20will%20see%20wider%20use_Electronic%20Design_06.07.07.pdf)
- Umeda, Toshiyuki, and Shoji Otaka. 2007. "ECO Chip: Energy Consumption Zeroize Chip with a 953MHz High-Sensitivity Radio Wave Detector for Standby Mode Applications." In *2007 Custom Integrated Circuits Conference. CICC'07. IEEE*, 663–666. IEEE.
- Urban, Bryan, Verena Tiefenbeck, and Kurt Roth. 2011. "Energy Consumption of Consumer Electronics in US Homes in 2010." *Fraunhofer Center for Sustainable Energy Systems*.
- USB-IF. Universal Serial Bus Power Delivery Specification, Version 1.2, Revision 3.0. 2018. Standard. <https://www.usb.org/sites/default/files/USB%20Power%20Delivery%2020181203.zip>
- U. S. Centers for Disease Control and Prevention. No date. COPD Among Adults in California. [https://www.cdc.gov/copd/maps/docs/pdf/CA\\_COPDFactSheet.pdf](https://www.cdc.gov/copd/maps/docs/pdf/CA_COPDFactSheet.pdf)
- U. S. Congress. 2017. H.R.511 - Power And Security Systems (PASS) Act. <https://www.congress.gov/bill/115th-congress/house-bill/511?r=257>

- U. S. Congress. 2007. Section 310(3) of EISA 2007; Pub. L. 110-140 (codified at 42 U.S.C. 6295(gg)) amended the Energy Policy and Conservation Act (EPCA). <https://www.congress.gov/bill/110th-congress/house-bill/6/text>
- U.S. Department of Energy. 2015. *Quadrennial-Technology-Review: An Assessment of Energy Technologies and Research Opportunities*. [https://www.energy.gov/sites/prod/files/2015/09/f26/Quadrennial-Technology-Review-2015\\_0.pdf](https://www.energy.gov/sites/prod/files/2015/09/f26/Quadrennial-Technology-Review-2015_0.pdf).
- U.S. Environmental Protection Agency. 2014. ENERGY STAR® Program Requirements for Imaging Equipment. Section 4.1(C) of the Version 2.0 test method: [https://www.energystar.gov/sites/default/files/FINAL%20Version%202.0%20Imaging%20Equipment%20Program%20Requirements%20%28Rev%20Oct-2014%29\\_0.pdf](https://www.energystar.gov/sites/default/files/FINAL%20Version%202.0%20Imaging%20Equipment%20Program%20Requirements%20%28Rev%20Oct-2014%29_0.pdf)
- U.S. Environmental Protection Agency. 2015. "ENERGY STAR® Program Requirements Product Specification for Large Network Equipment." <https://www.energystar.gov/sites/default/files/Final%20LNE%20V1.0%20Test%20Method.pdf>
- U.S. Food and Drug Administration. 2018. Radiation-Emitting Products and Procedures. <https://www.fda.gov/Radiation-EmittingProducts/RadiationEmittingProductsandProcedures/default.htm>
- U.S. Food and Drug Administration. 2019. Laser Products and Instruments. <https://www.fda.gov/radiation-emittingproducts/radiationemittingproductsandprocedures/homebusinessandentertainment/laserproductsandinstruments/default.htm>
- U. S. Nuclear Regulatory Commission. 2017. NRC Backgrounder on Smoke Detectors. <https://www.nrc.gov/reading-rm/doc-collections/fact-sheets/smoke-detectors.html>
- Vossos, Vagelis, Stephen Pantano, Ruby Heard, and Rich Brown. 2017. "DC Appliances and DC Power Distribution." <https://eta.lbl.gov/sites/default/files/publications/lbnl-2001084.pdf>
- Walker, Iain, Rengie Chan, and Brett Singer. 2019. "Ventilation and IAQ in New California Homes." *Home Energy Magazine* (Spring) 12–16.
- Weiss, R., L. Ott, and U. Boeke. 2015. "Energy Efficient Low-Voltage DC-Grids for Commercial Buildings." In *2015 IEEE First International Conference on DC Microgrids (ICDCM)*, 154–158. <https://doi.org/10.1109/ICDCM.2015.7152030>
- Willems, Simon, and Wouter Aerts. 2014. "Study and Simulation of A DC Micro Grid With Focus on Efficiency, Use of Materials and Economic Constraints." Leuven, Belgium: University of Leuven.
- Wilson, Dale. 2012. *Fire and Life Safety: Emergency Lighting*, Consulting-Specifying Engineer, June 2012. <https://www.csemaq.com/single-article/fire-and-life-safety-emergency-lighting/924837a1eb33386283ffd5d151cf3701.html>



- Wright, Maury. 2016. "Eaton Demonstrates Distributed DC Power for LED Lighting at LFI." *LEDs Magazine* May 4. <http://www.ledsmagazine.com/articles/2016/05/eaton-demonstrates-distributed-dc-power-for-led-lighting-at-lfi.html>
- Yamawaki, Akira, and Seiichi Serikawa. 2015a. "An Extending Method of Operable Distance for Infrared Remote Controlled Power Switch with Zero Stand-by Power." In *2015 International Conference On Informatics, Electronics & Vision (ICIEV)*, 1–5. IEEE.
- Yamawaki, Akira, and Seiichi Serikawa. 2015b. "Power Supply Circuit with Zero Standby Power Consumption on Infrared Remote Controlled Product by Using Energy Harvesting." In *Proceeding of the International MultiConference of Engineers and Computer Scientists 2015*. Vol. 2. Hong Kong. [http://www.iaeng.org/publication/IMECS2015/IMECS2015\\_pp655-660.pdf](http://www.iaeng.org/publication/IMECS2015/IMECS2015_pp655-660.pdf)
- Yukita, Kazuto, Tadashi Hosoe, Shunsuke Horie, Toshiro Matsumura, Masayoshi Hamanaka, Keiichi Hirose, and Masatoshi Noritake. 2017. "Air Conditioning Equipment Using DC Power Supply System." In *2017 IEEE International Telecommunications Energy Conference (IN<sup>TELE</sup>EC)*, 229–232. IEEE.

# APPENDIX A:

## Direct Current Capacitor Voltage in Brushless Direct Current Motors

---

Brushless DC (BLDC) motors are designed with an intended AC input voltage to the stator windings. See Figure A-1. The AC winding voltage is important because it dictates the inverter's DC input voltage from the DC capacitor bus. Direct-DC loads can be DC-connected if the nominal DC capacitor bus voltage is the same as the DC distribution voltage. This section shows how a motor's input voltage can be designed independently of its power rating, and can ultimately be designed such that the DC capacitor bus can seamlessly connect to the DC distribution.

**Figure A-1: Winding Area Diagram for Two Motors with Equal Input Power and Magnetic Flux**

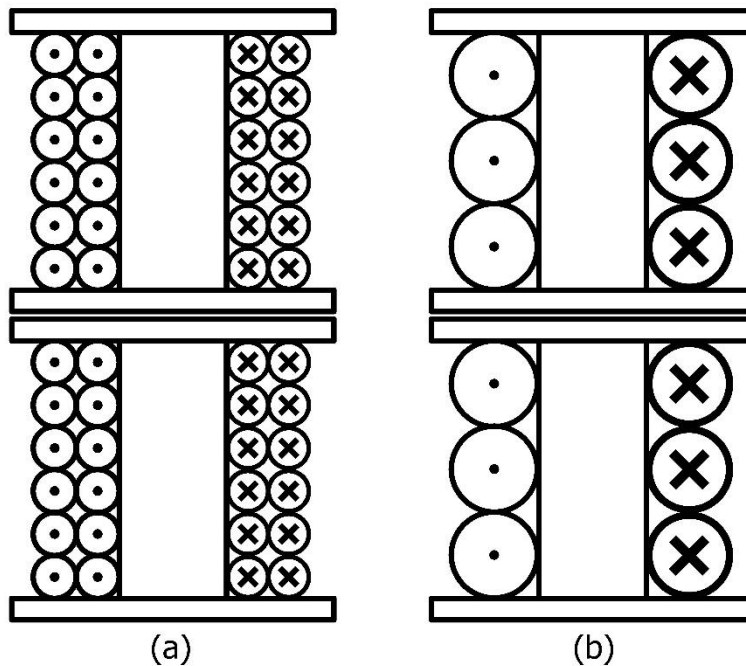

The winding area in both motors is roughly equal. (a) A high-voltage motor that requires 12 windings, but they can be relatively thin. (b) An equivalent low-voltage motor only requires 3 windings, but they must be thick enough for the relatively high winding current.

Source: LBNL

For a given application, assume that the motor's electrical input power  $P_{const}$  is specified and constant. Also assume that the motor's magnetic flux  $\Phi_{const}$  is constant and is directly related to the mechanical output power. The relations between the electrical stator windings and the magnetic core are:

$$P_{const} = VI \quad (1)$$

$$\phi_{const} = \frac{NI}{R_{tot}} \quad (2)$$

$$E = N \frac{d\phi_{const}}{dt}, \quad (3)$$

where  $V$  and  $I$  respectively are the winding's input voltage and current,  $N$  is the number of windings,  $R_{tot}$  is the total reluctance of the magnetic core, and  $E$  is the back EMF generated in the windings.

Consider a comparison between motors 1 and 2, which both have the same input power  $P_1 = P_2$ , and magnetic flux  $\phi_1 = \phi_2$ . However, the main difference is that the winding voltage of motor 1 is designed to be  $K$  times greater than that of motor 2. Since  $V_1 = KV_2$ , Eq. 1 assures that  $I_1 = \frac{1}{K}I_2$ . If the two motors are specified with the same magnetic flux and core parameters, then Eq. 2 requires that  $N_1 = KN_2$ . In other words, the motor 1 requires  $K$  times as many windings, but the windings only pass  $\frac{1}{K}$  times as much current. Finally, Eq. 3 follows that  $E_1 = KE_2$ , but since  $V_1 = KV_2$ , then each motor has proportionally as much voltage headroom, and each motor can attain the same maximum speed.

The overall result is that high-voltage motors use less current and have more stator windings than low-voltage motors of the same input power and flux. Since the low-voltage motor requires thicker windings capable of passing a higher current than the high-voltage motor. Nonetheless, the low-voltage motor requires fewer windings and so the overall winding packing window is comparable between the two motors, as shown in Figure 21.

Finally, the losses in the high and low-voltage motors are also equivalent. The core loss is equivalent because the flux  $\Phi$  is the same between the motors. For winding loss, the factor  $K$  falls out of the equations:

$$P_w = I^2 R_w \quad (4)$$

$$R_w = \rho \frac{L}{A}. \quad (5)$$

The wire loss power  $P_w$  and resistance  $R_w$  are dependent on the wire length  $L$ , cross sectional area  $A$ , and resistivity  $\rho$ . As shown in Fig. 21, the number of turns  $N_1 = KN_2$  requires motor 1 to have a smaller area  $A_1 = \frac{1}{K}A_2$ , and greater length  $L_1 = KL_2$ . As such, motor 1 has a greater wire resistance  $R_1 = K^2R_2$ . Nonetheless, the winding current  $I_1 = \frac{1}{K}I_2$ , and so the overall winding loss power  $P_1 = I_1^2 R_1 = (\frac{1}{K}I_2)^2 (K^2R_2) = P_2$ .

# APPENDIX B:

## Supplementary Material for Chapter 4

---

**Table B-1: Life-Safety Devices Purchased for Detailed Analysis**

Device ID	Manufacturer	Cost	Options
Smoke alarms			
SMA05	A1	\$14.97	Ionization, R/G LED, Wired Interconnect
SMA07	A1	\$49.97	Photoelectric, LED status ring, RF Interconnect
SMA36	A1	\$19.97	Photoelectric, R/G LED, Wired Interconnect
SMA02	A2	\$29.96	Photoelectric, R/G LED, Wired Interconnect
SMA03	A3	\$22.40	Photoelectric, R/G LED, Wired Interconnect
SMA44	A3	\$30.09	Dual, R/G LED, Wired Interconnect
SMA42	A6	*	Ionization, R LED, No Interconnect, No battery backup
CO alarms			
COA08	A1	\$32.97	Electrochemical, R/G/Y LEDs, Wired Interconnect
COA11	A1	\$52.47	Electrochemical, R/G LEDs, Wired Interconnect, digital display
COA09	A2	\$34.96	Electrochemical, R/G LEDs, Wired Interconnect
COA37	A3	\$47.60	Electrochemical, R/G LED, No Interconnect
Smoke/CO alarms			
SCA12	A1	\$49.97	Photoelectric/electrochemical, R/G LED, Wired Interconnect
SCA43	A1	\$47.97	Ionization/electrochemical, R/G LED, Wired Interconnect, Voice
SCA15	A1	\$79.97	Photoelectric/electrochemical, LED status ring, RF Interconnect
SCA13	A3	\$44.25	Photoelectric/electrochemical, R/G LEDs, Wired Interconnect
SCA14	A4	\$42.41	Proprietary sensor, R/G LEDs, Wired Interconnect
SCA16	A5	\$119.00	Split-spectrum/electrochemical, LED status ring, WiFi Interconnect
GFCI outlets			
GFO17	O1	\$13.97	R/G LED, Self-test
GFO18	O2	\$48.95	R/G LED, Self-test
GFO38	O3	\$13.97	R LED, Self-test
GFO39	O4	\$16.18	Replacement indicator, Self-test
GFO40	O5	\$55.60	R/G LED, Self-test

Device ID	Manufacturer	Cost	Options
GFCI breakers			
GFB22	B1	\$39.48	None
GFB23	B2	\$49.97	None
GFB24	B3	\$45.00	None
AFCI outlets			
AFO25	O1	\$19.98	R/G LED
AFO26	O3	\$21.98	R/G LED
AFCI breakers			
AFB27	B1	\$30.53	None
AFB28	B2	\$15.00	R LED
AFB41	B3	\$26.11	None
AFCI/GFCI outlets			
AGO30	O1	\$24.97	R/G LED, Self-test
AGO31	O3	\$29.97	R/G LED, Self-test
AFCI/GFCI breakers			
AGB34	B2	\$44.97	R LEDs
AGB35	B3	\$48.85	R LED

\* Device SMA42 was an old alarm from an existing home and so did not have a purchase cost.

Source: LBNL

## SSHD Test Method

- Turn on Chroma and start *Chroma 66200 Soft Panel* program
- Click on Scan Device
- Click on **Open** and choose *Base.Mea*
- Click on **Recording** and then **Open** and choose *rpd.Rpt*
- Open [SSHD Testing](#) google sheet, *Tests* tab.
- Un-LOTO the test fixture
- Measure Devices
- Remove device from packaging and mark with ID
- Record model number on *Test* tab
- Take a picture of the back and front of the device
- Install device in test fixture and plug test fixture into the Chroma
- Click on **Recording** to open the *Recording* window
- Click **Browse** in *Soft Panel Recording* window and name file using the device ID
- Click Record Start

- When recording is finished click on **Back** to close the *Recording* window
- Press **Alt + PrtScn** with *Soft Panel* window active
- Click on **Select**, select the waveform graph with the mouse, and click on **Crop**
- Open *Paint* program and click on **Paste**
- Click on **Save** and save PNG file using the device ID
- Check the data file and image file and add any notes to the *Test* tab
- Disconnect the test fixture from the Choma and remove the device
- Repeat as necessary
- LOTO the test fixture when finished with testing

**Table B-2: Selected SSHD Test Results**

Device ID	Voltage (VAC)	Current (amps)	Mean Power (watts)	Min Power (watts)	Max Power (watts)	Power Stdev (watts)	Power Factor	Distortion Power Factor	Displacement Power Factor	Regression Slope (watts/sec)
sma02	125.5	0.058	0.901	0.887	0.907	0.0047	0.124	0.939	0.132	5.99E-05
sma03	125.3	0.0397	0.58	0.573	0.582	0.0015	0.116	0.962	0.121	-1.14E-05
sma05	125.0	0.0731	1.185	1.168	1.192	0.0051	0.13	0.958	0.135	4.71E-05
sma07	125.4	0.0055	0.31	0.241	0.322	0.0241	0.447	0.484	0.924	-2.52E-04
coa08	125.2	0.0149	0.74	0.735	0.744	0.002	0.397	0.942	0.422	1.53E-05
coa09	125.6	0.0285	0.404	0.399	0.406	0.0013	0.113	0.934	0.121	-2.00E-05
coa11	125.1	0.0154	0.789	0.77	0.795	0.0055	0.408	0.947	0.431	-2.49E-05
sca12	125.3	0.0721	0.797	0.783	0.806	0.0054	0.088	0.932	0.095	-4.23E-05
sca13	124.6	0.0486	0.648	0.64	0.65	0.0018	0.107	0.962	0.111	2.06E-06
sca14	125.4	0.1101	1.227	1.216	1.238	0.0076	0.089	0.918	0.097	-9.43E-06
sca15	125.5	0.0054	0.307	0.239	0.318	0.0235	0.45	0.488	0.922	-6.60E-04
sca16	125.8	0.0065	0.42	0.412	0.43	0.003	0.513	0.513	1.001	3.12E-05
gfo17	125.3	0.0083	1.013	0.998	1.017	0.0029	0.977	0.992	0.984	-9.98E-06
gfo18	125.2	0.0076	0.895	0.88	0.9	0.0042	0.94	0.982	0.957	1.49E-06
gfb22	125.2	0.0048	0.599	0.59	0.6	0.0023	0.994	0.996	0.998	3.15E-05
gfb23	125.4	0.0084	0.558	0.556	0.559	0.0005	0.528	0.882	0.598	4.04E-06
gfb24	125.4	0.0052	0.648	0.635	0.651	0.0035	0.993	0.989	1.003	1.42E-05
afo25	125.6	0.0082	0.809	0.8	0.812	0.0032	0.784	0.868	0.903	-4.92E-05
afo26	125.6	0.0519	0.793	0.787	0.799	0.0031	0.122	0.322	0.377	1.97E-05
afb27	125.2	0.0065	0.702	0.697	0.703	0.001	0.856	0.876	0.977	1.37E-05
afb28	125.6	0.0577	0.843	0.832	0.849	0.0034	0.116	0.489	0.238	-2.69E-05
ago30	125.8	0.01	1.012	0.996	1.015	0.003	0.806	0.903	0.892	-1.83E-05
ago31	125.7	0.0047	0.362	0.36	0.363	0.0006	0.614	0.677	0.906	5.69E-06
agb34	125.3	0.0058	0.249	0.248	0.249	0.0002	0.345	0.850	0.405	-1.13E-06
agb35	125.4	0.0531	1.339	1.322	1.347	0.0055	0.201	0.380	0.529	-3.71E-05

Device ID	Voltage (VAC)	Current (amps)	Mean Power (watts)	Min Power (watts)	Max Power (watts)	Power Stdev (watts)	Power Factor	Distortion Power Factor	Displacement Power Factor	Regression Slope (watts/sec)
sma36	124.9	0.0702	0.99	0.977	0.992	0.0019	0.113	0.964	0.117	1.69E-05
coa37	125.1	0.0392	0.405	0.4	0.406	0.0012	0.082	0.930	0.089	-1.71E-05
gfo38	125.9	0.0076	0.958	0.942	0.963	0.0038	0.996	0.995	1.002	5.47E-05
gfo39	125.2	0.0076	0.682	0.672	0.686	0.0029	0.718	0.889	0.808	-1.02E-06
gfo40	124.8	0.0042	0.525	0.519	0.529	0.0023	0.993	0.993	1	1.63E-05
afb41	125.1	0.0053	0.653	0.644	0.656	0.002	0.985	0.993	0.992	4.58E-06
sma42	124.8	0.0132	1.167	1.149	1.172	0.004	0.709	0.894	0.793	5.37E-05
sca43	125.4	0.0051	0.314	0.314	0.315	0.0002	0.495	0.542	0.912	5.70E-07
sma44	125.7	0.0726	1.09	1.077	1.094	0.0033	0.119	0.932	0.128	1.51E-05

Source: LBNL