

Energy Research and Development Division
FINAL PROJECT REPORT

Decision Support Tool to Reduce Energy and Water Consumption in Agriculture

California Energy Commission
Gavin Newsom, Governor

March 2019 | CEC-500-2019-022



PREPARED BY:

Primary Author(s):

Olivier Jerphagnon, PowWow Energy (PI)
Stanley Knutson, PowWow Energy (PM)
Dr. Roland Geyer, UC Santa Barbara (co-PI)
Dr. Kate Scow, UC Davis (co-PI)

PowWow Energy, Inc
55 East Third Avenue
San Mateo, CA 94401
Phone: 415-658-7125 | Email: info@powwowenergy.com
<https://www.powwowenergy.com>

Contract Number: EPC-14-081

PREPARED FOR:

California Energy Commission

Anish Gautam
Contract Manager

Virginia Lew
Office Manager
ENERGY EFFICIENCY RESEARCH OFFICE

Laurie ten Hope
Deputy Director
ENERGY RESEARCH AND DEVELOPMENT DIVISION

Drew Bohan
Executive Director

DISCLAIMER

This report was prepared as the result of work sponsored by the California Energy Commission. It does not necessarily represent the views of the Energy Commission, its employees or the State of California. The Energy Commission, the State of California, its employees, contractors and subcontractors make no warranty, express or implied, and assume no legal liability for the information in this report; nor does any party represent that the uses of this information will not infringe upon privately owned rights. This report has not been approved or disapproved by the California Energy Commission nor has the California Energy Commission passed upon the accuracy or adequacy of the information in this report.

ACKNOWLEDGEMENTS

The work summarized in this report builds on innovative work patented by the primary investigator in 2013 and 2014. The primary investigator thanks the farms that participated in the early pilots as well as the advice from former Secretary Mike Chrisman and former Commissioner Jeff Byron.

Since the beginning of the project in 2015, PowWow Energy, Inc. (PWE) has collaborated with the Institute for Energy Efficiency at the University of California, Santa Barbara (UCSB), and the Agricultural Sustainability Institute at the University of California, Davis (UCD). To our knowledge, it was the first project in agriculture to integrate three cultures - technology innovation in Silicon Valley (PWE), environmental assessment (UCSB), and farming practices (UCD) - to address increasing challenges at the nexus of energy and water in agriculture.

The primary investigator thanks Jim Klingshirn from PWE, Dr. Roland Geyer from UCSB, and Dr. Kate Scow from UCD for their dedication to scientific collaboration and their commitment to educate a new generation of leaders who can tackle real-life problems. The team also worked closely with Dr. Chandra Krintz from UCSB and Dr. Daniele Zaccaria from UCD.

The highlight of the project was the participation of interns from agricultural schools and data science programs: California State University (CSU) Fresno, CSU San Luis Obispo, West Hills College Coalinga, AgroParisTech, and Stanford University. The ease by which students from different disciplines worked together is encouraging for the future.

The project would not have been possible without the participation of the six farms that made their fields available for the large-scale use. The project team learned that growers are innovators too. They are stewards of the land who think about they will leave to future generations. The primary investigator particularly thanks Don Cameron, Israel Herrera, and James Nichols for their collaboration over three growing seasons from 2015 to 2017. California went through the peak of the drought in 2015, an average year in terms of rainfall in 2016, and the wettest year on record in 2017. This gave the project team a unique perspective on the energy intensity of farming, and the many factors that growers deal with every year.

The sense of public service was a common trait among the four experts in alfalfa, almond, pistachio, and tomato who provided advice during the project: Allan Fulton, Dr. Khaled Bali, Dr. Kenneth Schackel, and Dr. Tim Hartz. They are part of the University of California Cooperative Extension system and an integral part of the farming community.

The team also thanks the constructive and the in-kind support of the hydraulics team of Southern California Edison and the Advanced Pump Efficiency Program at CSU Fresno sponsored by Pacific Gas and Electric.

Finally, the team thanks the contract managers at the California Energy Commission, Leah Mohny and Anish Gautam, for their continuous support and feedback.

PREFACE

The California Energy Commission's Energy Research and Development Division supports energy research and development programs to spur innovation in energy efficiency, renewable energy and advanced clean generation, energy-related environmental protection, energy transmission and distribution and transportation.

In 2012, the Electric Program Investment Charge (EPIC) was established by the California Public Utilities Commission to fund public investments in research to create and advance new energy solutions, foster regional innovation and bring ideas from the lab to the marketplace. The California Energy Commission and the state's three largest investor-owned utilities—Pacific Gas and Electric Company, San Diego Gas & Electric Company and Southern California Edison Company—were selected to administer the EPIC funds and advance novel technologies, tools, and strategies that provide benefits to their electric ratepayers.

The Energy Commission is committed to ensuring public participation in its research and development programs that promote greater reliability, lower costs, and increase safety for the California electric ratepayer and include:

- Providing societal benefits.
- Reducing greenhouse gas emission in the electricity sector at the lowest possible cost.
- Supporting California's loading order to meet energy needs first with energy efficiency and demand response, next with renewable energy (distributed generation and utility scale), and finally with clean, conventional electricity supply.
- Supporting low-emission vehicles and transportation.
- Providing economic development.
- Using ratepayer funds efficiently.

Decision Support Tool to Reduce Energy and Water Consumption in Agriculture is the final report for the "Irrigation optimization and Well Pump Monitoring to Reduce Water and Energy Consumption" project (contract number EPC-14-081) conducted by PowWow Energy, Inc. The information from this project contributes to Energy Research and Development Division's Industrial Agriculture and Water End-Use Energy Efficiency Program.

For more information about the Energy Research and Development Division, please visit the Energy Commission's website at www.energy.ca.gov/research/ or contact the Energy Commission at 916-327-1551.

ABSTRACT

In collaboration with the University of California, PowWow Energy developed software that uses energy data from investor-owned utility smart electric meters to calculate water flow volumes for irrigation well pumps and booster pumps. No installation of new pump hardware is required to make these measurements. Growers are offered a software-as-a-service product that automates water records and optimizes irrigation schedules to reduce energy and water use for irrigation without harming the crops or negatively affecting yields.

The team conducted commercial-scale tests of the technology at six commercial farming sites in the Sacramento and San Joaquin valleys located in Pacific Gas and Electric and Southern California Edison service territories. The sites encompassed more than 4,000 acres containing a mix of tree crops (almond and pistachio), row crops (tomato), and field crops (alfalfa). The accuracy of the method for measuring water flow from smart meter data was assessed against calibrated water meters at more than 20 pumps in six different basins. A mean error of 4 percent and a maximum error of less than 10 percent were observed, which meets the new California requirements for monitoring groundwater and surface water use.

Energy and water use and crop yields at the sites were monitored over multiple years to capture the seasonality of agricultural operations and environmental conditions. The team observed 8 percent to 33 percent in energy savings from pump monitoring and irrigation optimization, with an average improvement in energy efficiency (energy savings for the same production level) of 13 percent across a variety of crops and geographies. Water use efficiency was improved by 9 percent. If this technology was installed for 20 percent of the 2.4 million acres cultivated in California for almond, pistachio, tomatoes, and alfalfa annual savings could be more than 66 gigawatt-hours of electricity and 120,000 acre-feet of water.

Keywords: Agriculture, investor-owned utilities, water, energy, water use efficiency energy efficiency, irrigation efficiency, deficit irrigation, groundwater, surface water drought, Groundwater Sustainable Agency, remote sensing, smart meter, and machine learning.

Please use the following citation for this report:

Jerphagnon, Olivier; Stanley Knutson; Roland Geyer; Kate Scow. (PowWow Energy). 2019. *Decision Support Tool to Reduce Water and Energy Consumption in Agriculture*. California Energy Commission. Publication number: CEC-500-2019-022.

TABLE OF CONTENTS

Acknowledgements.....	i
PREFACE.....	ii
ABSTRACT.....	iii
TABLE OF CONTENTS	iv
LIST OF FIGURES.....	vii
LIST OF TABLES.....	xii
EXECUTIVE SUMMARY	1
Background	1
Project Purpose	2
Project Approach.....	3
Project Results	4
Technology Transfer and Market Adoption	6
Benefits to California.....	7
CHAPTER 1: Introduction to Water-Energy Nexus in Agriculture	8
1.1 Energy Intensity of Irrigation in California	9
1.1.1 Water Intensity of Farming	9
1.1.2 Energy Intensity of Pumping.....	10
1.1.3 Measurement and Verification Based on Life Cycle Assessment	11
1.2 Tragedy of the Commons.....	12
1.3 Sustainable Groundwater Management Act (SGMA).....	13
1.4 Gap Between Groundwater Monitoring and Irrigation Scheduling	14
CHAPTER 2: Groundwater Measurement Leveraging Smart Meters	17
2.1 Water Records From Electrical Data	18
2.1.1 Green Button Standard	19
2.1.2 Pump Efficiency Test Programs	21
2.1.3 Single-speed Pump.....	21
2.1.4 Variable-speed Pump.....	22
2.2 Accuracy Analysis for CCR Title 23 Certification.....	23
2.2.1 New Surface and Ground Water Monitoring Requirements.....	23
2.2.2 Data Collection at 20 Pumps Measured Across Six Groundwater Basins	24
2.2.3 Statement of Verification of PWE Method by Bren School of Environmental Science and Management at UCSB.....	26
2.3 Comparison with Other Water Measurement Techniques	28

2.3.1	Mechanical Meter with Manual Readings	28
2.3.2	Magnetic Meter with Telemetry System	29
2.3.3	PWE Method Leveraging Smart Meters	30
2.3.4	Comparison of Water Measurement Accuracy	30
2.4	Environmental and Economic Impact	32
CHAPTER 3: Irrigation Strategies for Annual and Perennial Crops		33
3.1	Rational Irrigation Based on Evapotranspiration (ET).....	34
3.1.1	Irrigation Scheduling Based on ET	34
3.1.2	Crop ET Based Measurements	37
3.1.3	Soil Moisture Based Measurement.....	38
3.1.4	Plant Water Based Measurements.....	40
3.2	Deficit irrigation (DI) based on advanced phenology models	42
3.2.1	Nut Crops.....	42
3.2.1.1	Almond	43
3.2.1.2	Pistachio	47
3.2.2	Tomato	49
3.2.3	Alfalfa	51
3.3	Common Methodology to Use Optimized Irrigation Schedule	52
3.3.1	Check Irrigation System and Pumping Plant Infrastructure.....	53
3.3.2	Start with Irrigation Schedule Based on Crop ET and Soil Type.....	55
3.3.3	Validate Schedule with On-Farm Sensors and Aerial Images	56
3.3.4	Option: Deficit Irrigation During Drought.....	56
CHAPTER 4: Data Integration to Support Vendor Neutral Platform		58
4.1	Weather Data.....	59
4.1.1	California Irrigation and Management Information Service (CIMIS)	59
4.1.2	National Weather Service (NWS).....	60
4.1.3	DTN - The Progressive Farmer.....	60
4.2	Aerial Images	62
4.2.1	Multi-Spectral Images.....	63
4.2.2	Geo-Registration and Calibration	65
4.2.3	Standard Output Formats	69
4.3	Examples of On-Farm Sensors	72
4.3.1	ET-Based Sensor: Surface Renewal Station From Tule Technologies.....	73
4.3.2	Soil-Based Sensors: Tensiometer From Irrrometer.....	75

4.3.3	Plant-Based Sensor: Pressure Chamber	75
CHAPTER 5:	Optimized Irrigation Software-as-a-Service	77
5.1	Field Configuration for Irrigation Schedule	77
5.1.1	Configuration of Irrigation System	77
5.1.2	Crop Model	79
5.1.3	Weekly Irrigation Schedule	82
5.2	Email Notification of New Imagery	83
5.2.1	Large-scale Image Processing	83
5.2.2	Email Notification	84
5.3	Irrigation Optimization: “Closing the Loop”	85
5.3.1	Comparing Water Application Against ET Schedule	85
5.3.2	Tracking Deficit Irrigation Schedule Against a Target Value	87
5.3.3	Managing Spatial Variability With Monthly Aerial Imagery	90
CHAPTER 6:	Deployment at Six Sites Representing Over 4,000 Acres of Farmland.....	93
6.1	Description of Experiments	94
6.1.1	Site #1 - Nichols Farms Near Hanford (pistachio)	94
6.1.2	Site #2 - Sierra View Farms Near Tulare (Almond and Pistachio)	95
6.1.3	Site #3 - Russell Ranch (Tomato)	102
6.1.4	Site #4 - Meek & Sons (Tomato).....	104
6.1.5	Site #5 - Button & Turkovich (Alfalfa).....	107
6.1.6	Site #6 Terranova Ranch (Multiple Crops).....	108
6.2	Collection of Data and Baselineing	110
6.2.1	Collection of Water, Wnergy, and Yield Data.....	110
6.2.2	Developing a Baseline Using Life Cycle Assessment	112
6.2.3	Lessons Learned from the Deployment Experiments	114
CHAPTER 7:	Results From Measurement and Verification.....	117
7.1	Life Cycle Assessment (LCA) Approach	117
7.1.1	Water Use Intensity.....	118
7.1.2	Energy Use Intensity.....	119
7.1.3	Normalization of External Factors	121
7.2	Results From the Deployments.....	122
7.2.1	Water Intensity Results.....	122
7.2.2	Energy Intensity Results	125
7.2.3	Normalization Considerations	126

7.3	Review of Benefits and Impact on California.....	131
7.3.1	Water Savings.....	134
7.3.2	Energy Savings	134
7.3.3	Reductions in GHG Emissions and Energy Costs.....	134
CHAPTER 8: Workshops with Farms, Utilities and Agencies		135
8.1	Technology Adoption by Farms.....	136
8.1.1	Diffusion Process: Difference in Technology Adoption	136
8.1.2	Field Days: Role of the Cooperative Extension.....	137
8.1.3	Closing the Cultural Gap Between Silicon Valley and Central Valley.....	143
8.2	Developing Energy Efficiency Program with Utilities.....	145
8.2.1	Pacific Gas & Electric (PG&E).....	145
8.2.2	Southern California Edison (SCE).....	148
8.3	Pilots with State and Local Agencies	150
8.3.1	Statewide Water Efficiency and Enhancement Program (SWEEP).....	150
8.3.2	Irrigation Evaluations by Resource Conservation Districts (RCD)	151
8.3.3	Groundwater Sustainability Agencies (GSA)	153
CHAPTER 9: Conclusions and Recommendations.....		154
9.1	Deploy simple decision-support tool as farming dashboard	154
9.2	Coordinate Advanced Decision Support Tool (Deficit Irrigation) with Groundwater Recharge to Manage Crops During Dry and Wet Years	156
LIST OF ACRONYMS AND ABBREVIATIONS.....		158
REFERENCES.....		162
APPENDICES.....		207

LIST OF FIGURES

Figure 1: Location of the Project Sites.....	3
Figure 2: Approach to Address the Gap Between Farming Practices and Pump Maintenance	3
Figure 3: Measurement Errors for PWE Water Measurement Method Leveraging Smart Power Meter Data and for Mechanical Flow Meters (Field) and Magnetic Meters (Laboratory).....	5
Figure 4: Market Adoption Before the Project Started (Left) and After It Ended (Right).....	7
Figure 5: Transpiration Through the Stomata of a Leaf.....	10
Figure 6: Life Cycle Assessment (LCA) of Food	11
Figure 7: Average Annual Runoff and Precipitation for Historic Droughts.....	12
Figure 8: Groundwater Basin Prioritization	14

Figure 9: Approach to Solve the Gap Between Groundwater Monitoring and Irrigation Scheduling	15
Figure 10: Example of Smart Meter at a Pumping Station for Irrigation at an Almond Orchard.	18
Figure 11: Relationship Between Water Flow and Horsepower of a Pump.....	18
Figure 12: Implementation of Green Button Connect-My-Data by PG&E	20
Figure 13: Implementation of Green Button Connect-My-Data by SCE.....	20
Figure 14: Single Speed Pump Curve	21
Figure 15: PowWow Web Application With Pop-up “Pump Tests” Tab	22
Figure 16: Variable Speed Pump Curves	22
Figure 17: Location of the Verification Tests to Measure the Accuracy of PWE System.....	24
Figure 18: Magnetic Meters Installed at Two Pumping Stations at Site #6 in Helm, California....	25
Figure 19: Acoustic Meters Temporarily Installed at One Pumping Station During the Project ..	26
Figure 20: Boxplot Comparison of the Three PWE Algorithm Versions Tested During the Project	27
Figure 21: Providing 100% Monitoring Coverage for SGMA With Various Metering Methods	28
Figure 22: Bolt-on-Saddle Mechanical Meter	29
Figure 23: Magnetic Meter.....	30
Figure 24: Comparison of Three Systems for Measuring Groundwater Extraction.....	31
Figure 25: Constructed Crop Coefficient Curve for Different Stages of Plant Development.....	35
Figure 26: Comparison Between Shaded Area, ET, and Mature Trees.....	36
Figure 27: Soil Water Retention Curves for Different Soil Textures	39
Figure 28: Almond Fruit Development Stages.....	44
Figure 29: Relation Between Average Crop Coefficient and Canopy Coverage.....	51
Figure 30: Comparing Application Rate (Field) and Flow Capacity (Pump) in Gallons per Minute	53
Figure 31: Example of Good (Left) and Poor (Right) Distribution Uniformity (DU).....	54
Figure 32: Drop in Power Level During the Season as the Water Table is Falling	55
Figure 33: ET Schedule for a Mature Almond Orchard Near Tulare	55
Figure 34: Validation of Irrigation Schedule with Soil Probes (Left) and Aerial Images (Right) ...	56
Figure 35: ET Schedule for a Mature Almond Orchard Near Tulare	57
Figure 36: PowWow Energy’s Vendor-Compatible Data Platform	58
Figure 37: Integration of Historical ET ₀ Data (Spatial CIMIS) and Forecast Data (NWS)	60
Figure 38: Integration of Rainfall Forecast (Left) and Measurement (Right) for One Site.....	61
Figure 39: Example of NDVI Image for an Almond Orchard in San Joaquin Valley	62
Figure 40: Processing Steps to Integrate Aerial Images Used Reliably in the Field.....	63
Figure 41: Example Twin Turboprop Aircraft for Capturing Imagery of Farms	64

Figure 42: Camera System Mounted in the Belly of the Aircraft	64
Figure 43: Four Images Captured NIR-band, Red-band, Green-band, Color-bands (RGB)	65
Figure 44: NIR, Red, Green Channels Combined Into Single Color Image	65
Figure 45: Overview of Geo-Registration Process	66
Figure 46: Feature-Based Technique for Geo-Registration of Aerial Images	67
Figure 47: Overview of Calibration Process	67
Figure 48: Calibration of Aerial Image	68
Figure 49: Typical Reflectance Sensitivities for Different Spectral Wavelengths to Leaf Pigments, Cell Structure, and Water Content	69
Figure 50: Example NDVI With False Color	70
Figure 51: Closeup of NDVI Image of Field With Three Color Maps.....	70
Figure 52: Examples of Extracted Fields	71
Figure 53: Geo-Registered Field-Level NDVI Imagery of a Vineyard Overlaid in GIS Software	72
Figure 54: Web Application Display of Field-Level NDVI	72
Figure 55: Generic Sensor Adapter Architecture	73
Figure 56: ET Station From Tule Technologies at One Site.....	74
Figure 57: ET _a Data and Irrigation Events from Tule Technologies Telemetry Station	74
Figure 58: Tensiometer Data From Tule Technologies Telemetry Station.....	75
Figure 59: Manual Data Shared by the Farm via a DropBox Folder Connected to PWE Server	76
Figure 60: Display of Stem Water Potential (SWP) Data via PWE Application.....	76
Figure 61: PowWow Irrigation Advisor Overview.....	77
Figure 62: Entering Field Shape	78
Figure 63: Crop Coefficient Table for Almonds with Partial Irrigation Enabled.....	80
Figure 64: Almond Orchard Blooming	81
Figure 65: Bloom Date has Major Impact on Water Required	81
Figure 66: Suggested Irrigation Hours Display in User Interface	82
Figure 67: Example of Email Message with Weekly Suggested Irrigation Schedules.....	82
Figure 68: Aerial Imagery for a Ranch with Multiple Fields	83
Figure 69: Access for Field Images by Date	84
Figure 70: Email Notification That New Images are Available at a Ranch.....	84
Figure 71: Comparison of Pumping Hours and ET Schedule for One Week at a Pistachio Orchard	85
Figure 72: Comparison of Water Applied (Inches) with ET schedule at an Almond Orchard.....	86
Figure 73: Evolution of Stem Water Potential (Bars) During the Growing Season of an Almond Orchard Near Tulare	87

Figure 74: Evolution of Soil Moisture in Volumetric Content (Inches) During the Growing Season of an Olive Orchard near Fresno	87
Figure 75: ET_a and ET_c Amounts (Inches) for a Tomato Field at Russell Ranch (UCD)	88
Figure 76: BRIX Levels in Tomatoes Before (Blue) and After (Orange) Deficit Irrigation	89
Figure 77: Comparison of Two Pistachio Fields Under Full-ET and Partial-ET Irrigation Schedules	89
Figure 78: Evolution of a Figure of Merit Called FieldStat by the ET_a Sensor Vendor	90
Figure 79: Correlation Between Stomatal Conductance From Thermal Imagery and SWP	91
Figure 80: Growth Curves of an Almond Orchard Generated From Near Infra-red Images	92
Figure 81: Locations of Project Deployment Sites	93
Figure 82: Description of the Experiment at the Pistachio Fields Near Hanford	94
Figure 83: Smart Meter Data in 2014 to 2017 for Well Pump Drummond A North	95
Figure 84: Description of the Experiment at the Almond Fields Near Tulare	96
Figure 85: Description of the Experiment at the Almond Fields Near Tulare	97
Figure 86: Comparison of Applied Water with ET and DI Schedules for 2014 at field AKE-D	98
Figure 87: NDVI Image of AKE-D in July 2014	98
Figure 88: Infiltration of Water During a Flood Irrigation Event	99
Figure 89: Deficit Irrigation Implemented Correctly at the Almond Orchard AKE-D in 2016	100
Figure 90: Evolution of Vegetation Uniformity Across 2014, 2015, and 2016 Seasons	100
Figure 91: Evolution of SWP During 2016 Season for Tree in Lighter Soil Area of AKE-D Field	101
Figure 92: Evolution of SWP During 2016 for Tree in Heavier Soil Area of AKE-D Field	101
Figure 93: Description of the Russell Ranch Site	102
Figure 94: Description of the Deficit Irrigation Experiment at Russell Ranch	103
Figure 95: Comparison of Water Applied for the Four Treatments in 2017	104
Figure 96: Description of the Experiment at the Tomato Field Near Davis	105
Figure 97: Smart Meter Data from the Well Pump at Site #4	106
Figure 98: Comparison of Irrigation Records with ET Schedule for Tomato	106
Figure 99: Description of Alfalfa Field at Site #5 (Left); Flood Water Applied with a Layflat (Right)	107
Figure 100: Description of the Main Ranch at Terranova Ranch Inc. (TRI)	108
Figure 101: Difference in Solar Energy Generation Between 2016 and 2017	109
Figure 102: Measurement of Groundwater Table in 2016 and 2017 at Pump 19 at Site #6	109
Figure 103: Tomato Harvest at Site #4 (Left) and Almond Drying After Shake at Site #2 (Right)	111
Figure 104: Examples of Water Management Units: Site #4 (Left) and Site #2 (Right)	113
Figure 105: Energy Data at One of the Pumps at Site #2	113

Figure 106: Variation on Vegetation Index (NDVI) at Site #4	114
Figure 107: Relationship Between the Two Components of Farm Energy Intensity	119
Figure 108: Calculation of Field Energy Intensity	120
Figure 109: Average Water Table Elevation at CASGEM Registered Wells Near Sites #1, #2, and #5.....	131
Figure 110: Water Use in California in Dry Years and Wet Years.....	135
Figure 111: Technology Adoption Cycle	136
Figure 112: Grower Panel Led by CDFA Science Advisor Dr. Gunasekara During the Last Session	137
Figure 113: Field Day on June 8, 2016 at Russell Ranch.....	138
Figure 114: Field Day at Russell Ranch and PWE Featured in AgAlert.....	139
Figure 115: Flyer for the Field Day at Hansen Ag Research & Extension Center Near Ventura..	139
Figure 116: Field Demonstration: Talk on Automated Water Records	140
Figure 117: Grower and Entrepreneur Panel Led by Jim Dunning From Cal Poly Technology Park	141
Figure 118: Third Field Day Near Fresno on October 26, 2016, With More Than 60 Growers ...	142
Figure 119: Field Day at Terranova Ranch	143
Figure 120: Panel on Processing Tomato led by Virginia Lew from California Energy Commission	143
Figure 121: PWE Staff Participating in an Event in Woodland with the Local Technology Incubator Focused on Agriculture	144
Figure 122: History of Energy Use of the Irrigation Pump at a Ranch from 2013 to 2018	145
Figure 123: Data Logs to Document Intentional Changes to Save Energy.....	146
Figure 124: Demonstration of SmartMeter Data Analytics at World Ag Expo.....	147
Figure 125: Pump Monitor Pilot Sponsored by SCE in Three Counties: Tulare, Ventura, and Riverside	148
Figure 126: Farm Near Ventura Participating in the SCE Pilot in 2017	149
Figure 127: List of Enhancements That Can be Supported by SWEEP Funds Managed by CDFA	150
Figure 128: Example of Dashboard Developed for SWEEP Managed by CDFA.....	151
Figure 129: Correlation Between Aerial Imagery and On-the-Ground DU Tests.....	152
Figure 130: Groundwater Recharge Experiment at a Vineyard at Site #6 Near Fresno	153
Figure 131: Energy and Water Management Dashboard for Farms	155
Figure 132: Panel on Recharging Groundwater During Wet Years in the San Joaquin Valley	156
Figure 133: Possible Impact of Implementing Deficit Irrigation and Groundwater Recharge	157

LIST OF TABLES

Table 1: Energy and Water Savings Observed at the Project Sites	5
Table 2: Required Measurement Accuracy and Monitoring Frequency for SB 88.....	23
Table 3: Statistical Results of the PWE Algorithms From the 69-Measurement Dataset.....	26
Table 4: Summary of Accuracy Associated with the Three Water Measurement Methods	31
Table 5: Comparison of the Environmental and Economic Impact of the Three Measurement Systems	32
Table 6: Crop Coefficients (K_c) for Processing Tomatoes, Alfalfa, Almonds and Pistachios.....	35
Table 7: Recommended Values of Soil Moisture Content at Which Irrigation Should Occur for the Different Soil Textures	40
Table 8: Recommended Values of Soil Moisture Tension at Which Irrigation Should Occur for the Different Soil Textures	40
Table 9: Example of Deficit Irrigation Levels (DIL) for Almonds.....	46
Table 10: Deficit Irrigation Level (DIL) for Pistachio Trees.....	48
Table 11: Proposed Deficit Irrigation Levels (DIL) for Processing Tomatoes	50
Table 12: Comparing Precipitation Data from the DTN Service With Weather Station Measurements.....	61
Table 13: Relative Importance of Each Feature to Predict Stem Water Potential (SWP)	92
Table 14: Summary of the Yield and Solid Content for all Treatments in 2017.....	104
Table 15: Comparison of Different Methods of Measuring Water at Site #4 During 2016 Season	110
Table 16: Review of Yield Measurement by Crop	112
Table 17: Energy Intensity of Pumping at the Study Sites in 2015 and 2017	115
Table 18: List of Different Functional Units Specific to Each Test Site.....	117
Table 19: Data Sources Available at Each Site to Estimate Total Volume of Water Applied to Each of the Fields Within the Study.....	118
Table 20: List of Factors That May Cause Yield Energy or Water Use to Vary	121
Table 21: List of Crop-specific Factors that Could Cause Significant Variation in Yield.....	121
Table 22: Overall Results in Energy and Water Use Intensity from Treatments.....	122
Table 23: Results for Water Use Intensity at All Sites in 2016	123
Table 24: Results from 2017 Experiments at Site #3 (Russell Ranch).....	124
Table 25: Changes in Pumping energy Intensity (MWh/ac-ft) for Each Project Site.....	125
Table 26: Percentage Change of Field Energy Intensity Relative to the Control Field at Each Site	126
Table 27: Matrix of External Factors That May Have Affected Yield or Energy/Water Use at Site #1 and Site #2 During the Experiment	127

Table 28: Matrix of External Factors That May Have Affected Yield or Energy/Water Use at Site #3, Site #4, and Site #5 During the Experiment	128
Table 29: Matrix of Factors That May Have Had an Effect on Pumping Energy Intensity at the Project Sites.....	130
Table 30: Cultivated Acreage (2016 Crop Year) and Average Water Application in California for the Four Crops Investigated During the Project	132
Table 31: Projected Market Penetration and Associated Water Savings, Energy Savings, and GHG Emission Reductions	133

EXECUTIVE SUMMARY

Background

The connections between water and energy resources in California are well established and understood. Treating, storing, and moving water accounts for nearly 20 percent of California's total electricity consumption and 30 percent of non-power plant natural gas consumption. California's extensive agriculture industry is the largest developed water user in the state, using more than 40 percent of the state's total fresh water supply.

Agricultural water use consumes 10 terawatt-hours (TWh) of electricity per year, which represents approximately one-fifth of all water-related electricity consumption and 4 percent of total electricity consumption in California. Because the electricity to power water pumping is supplied by power plants that burn fossil fuels, water use in agricultural operations contributes significantly to the state's overall carbon footprint and greenhouse gas (GHG) emissions. Reducing the electrical demand for water pumping reduces GHG emissions.

Agricultural energy-water links are amplified during periods of drought, when reduced availability of water resources has a triple effect on the grid with 1) low stream and lake levels result in lower production from hydroelectric power stations; 2) farmers consume more power as they pump more groundwater from wells to compensate for the reduction in runoff water supplied by the state; and 3) groundwater is pumped from deeper wells due to lowering of the water table, requiring more power to pump a given amount of water. In 2014, at the peak of the 2012-2016 drought, California farms pumped an additional 5 million acre-feet of groundwater to compensate for the lack of rain and surface water, resulting in an additional \$454 million of energy costs along with a commensurate increase in GHG emissions. In addition to creating further economic burdens for growers, excessive groundwater extraction depletes the state's groundwater resources.

In 2015, Governor Edmund G. Brown, Jr. signed the Sustainable Groundwater Management Act (SGMA), establishing Groundwater Sustainability Agencies (GSAs) for 127 medium- and high-priority groundwater basins that account for approximately 96 percent of groundwater extraction statewide. GSAs will be responsible for developing plans to address undesirable results of overpumping, such as depletion of groundwater reservoirs and land subsidence, within 20 years of their implementation. These new agencies will have the authority to require farms to monitor their groundwater extraction and assess fees for non-compliance. They will also organize remediation plans, such as groundwater recharge projects, deficit irrigation, and volunteered fallowing.

To comply with SGMA, farmers require a reliable method for measuring and keeping records of their groundwater use. Conventional methods involve the installation of mechanical water flow meters inline with groundwater pumps, which is costly and requires ongoing maintenance and calibration to ensure accuracy. Additional complexity is created by the gap that exists between monitoring water extraction and water application. Growers think about the amounts of water applied onto fields in units of inches of water as the metric whereas pump records for water

extracted from different sources are typically given in units of acre-feet. The energy costs associated with water pumping depend on specific time-of-use electricity rates. These differences make reporting water use time-consuming and disconnected from farming practices which require knowledge of how much water is applied for irrigation of specific crops. This project addressed the root cause of these issues by providing a simple and scalable software-based method that integrates water pump models and electricity use data from investor-owned utility (IOU) smart meters, presents water measurements to farmers in units of inches of water as well as acre-feet, and automatically keeps records of water and energy data.

This project developed a software-based tool that allow farmers to monitor their groundwater extraction and irrigation system efficiency using data from smart electric utility power meters, remote sensing, aerial imaging, and on-farm sensors. This will provide farmers with better information to manage and optimize their irrigation practices.

Widespread adoption of new irrigation schedule management based on evapotranspiration or deficit irrigation has been slow because they represent a major paradigm shift for many growers. Farmers are understandably hesitant to try new irrigation methods that deliver less water to their fields, which has the perceived risk of imperiling the health of their crops. For farmers, whose livelihoods depend on their crop yields, the fear of crop revenue losses outweighs any potential benefits of reducing water and energy consumption. These concerns are addressed by the software tool developed in this project, which offers farmers a way to monitor and verify the health of their crops while implementing efficient irrigation strategies using methods familiar to them.

Project Purpose

Farms require solutions to optimize delivery of water from the pump to the plant without incurring high costs or placing excessive burdens on their operations. The software-based approach taken in this project will not require the installation of any new infrastructure or hardware and can be integrated with current farming practices without disrupting other on-farm activities. The software tool developed in this project will integrate data from a wide array of sources and present it to farmers in a straightforward, intuitive way to provide them with practical information about their use of water and energy for irrigation and the health of their crops with the goal of making farmers comfortable with data-driven irrigation.

The first goal of the project was to demonstrate that the software platform could provide a simple, accurate, and cost-effective tool to meet SGMA regulatory compliance by leveraging existing smart grid infrastructure funded by IOU ratepayers. This new technology involves statistical analysis and pattern recognition techniques, commonly known as “artificial intelligence” or “machine learning”. This is a game-changer as it provides a neutral water measurement method to an underserved market facing once-in-a-generation regulatory change.

The second goal of the project was to provide a commercial-scale demonstration of a decision-support tool that will help farmers implement more efficient irrigation strategies to demonstrate a 20 percent reduction in energy and water use.

More precise water management has multiple benefits to both farmers and ratepayers, including lower energy costs, higher penetration of renewable energy sources, and uninterrupted availability of water. Another societal benefit is better coordination and stewardship of groundwater resources. Results from this project will be used by farms to improve resource use efficiencies, by power utilities to use new performance-based programs, and by local water agencies to balance water demand and supply.

Project Approach

The software tools and methodology were used at six sites spanning the territories of two IOUs (PG&E and SCE) and four groundwater basins encompassing widely differing conditions (Figure 1).

This project addressed the differences between water extraction and water application by providing a feedback loop between the pump infrastructure and field activities (Figure 2). Every effort was made to meet utility appliance and equipment standards for pumps and to follow the advice of agronomists to compare “control” and “treatment” plans (irrigation) within the same season. There are more than 300 crops grown in California, and many vendors in the past have made the mistake of taking a shortcut by integrating a sensor device into a proprietary method that is optimized to irrigate one specific crop but not for others. This approach addresses the problem.

Figure 1: Location of the Project Sites

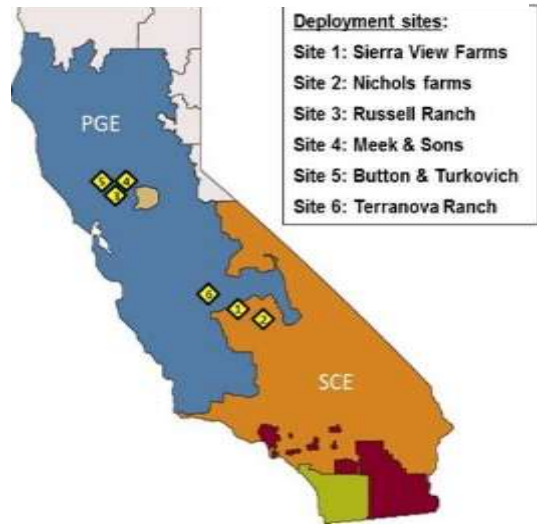
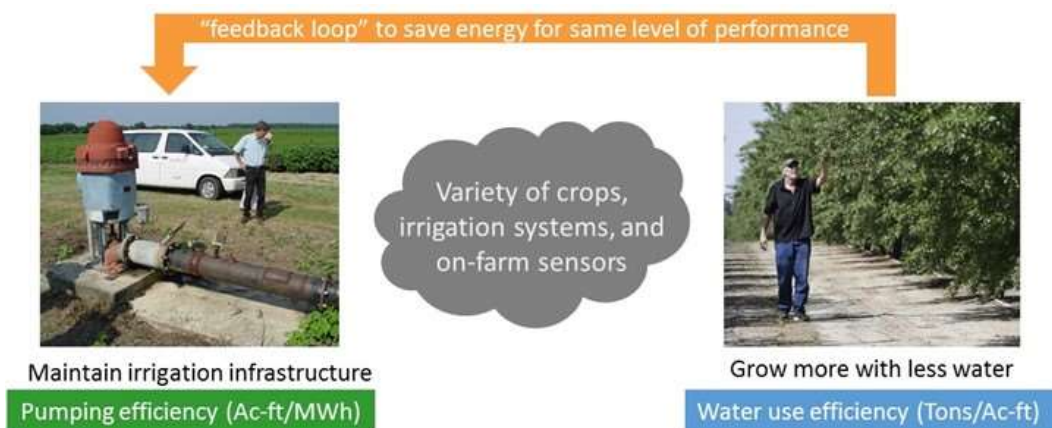

Figure 2: Approach to Address the Gap Between Farming Practices and Pump Maintenance



Source: PowWow Energy, University of California Davis, and University of California Santa Barbara

Two separate critical project approaches were used. First, the project team leveraged existing smart meters used by electric utilities to provide automated water records that meet California standards for water reporting under Title 23 of the California Code of Regulations. The team

improved the performance of the software algorithms by carrying out three rounds of tests and collecting ground-truth data at 20 pumps in five different locations.

Second, the project team developed a new “software-as-a-service” platform that can automate irrigation scheduling and assist growers weekly with farming decisions to water less during drought years without significant impacts to crop yields. The platform integrated crop models, aerial images, and on-farm sensors with energy and water records to provide a full management solution (“decision-support tool”) for the farms. Optimized irrigation strategies were selected at each site after setting an historical baseline. The six sites encompassed four widely-grown crops (almond, pistachio, tomato and alfalfa, which represent more than 2 million acres of cultivated farmlands in California) and different irrigation systems (drip irrigation, sub-drip irrigation, and flood irrigation).

A major challenge was encountered near the end of the project. Where the 2015 season marked the height of California’s drought, the winter of 2016/2017 was the wettest on record. This changed farmers’ perceptions about irrigation practices. One site did not want to reduce water application in 2017 and instead increased the amount of irrigation in early 2017 to leach salt accumulated in the soil by years of previous groundwater pumping.

The project’s technical advisory committee was essential in adapting project plans in 2017 to make the decision-support tool useful to farms in wet years while respecting the main objective of saving water and energy. The technical advisory committee was formed to address the main areas of expertise in the project: pump efficiency, agronomy, and farming.

Project Results

The project demonstrated that smart meter data can be used to provide daily water records that help with on-farm water management. The accuracy of this new method was assessed against calibrated water meters at more than 20 pumps in six different basins (Figure 3). The University of California Santa Barbara (UCSB) reported an average error of 4 percent and a maximum error of less than 10 percent, which meet the new SGMA state requirements for groundwater and surface water measurements. The graph shows the types of flow meters typically used (Acoustic 1, 2, 3, etc)

Figure 3: Measurement Errors for PWE Water Measurement Method Leveraging Smart Power Meter Data and for Mechanical Flow Meters (Field) and Magnetic Meters (Laboratory)

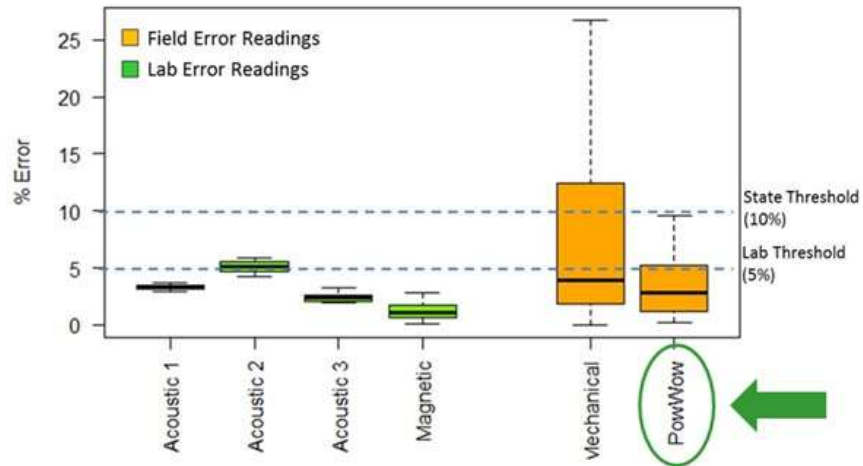

Title 23 thresholds are marked by the dotted line as “State Threshold”.

Source: University of California Santa Barbara, California State University Fresno, and PowWow Energy

UCSB led a complete life cycle assessment and compared the results with two other techniques. Across the six project sites, energy savings of 9 to 31 percent were observed as a result of pump monitoring and irrigation optimization, with a weighted average improvement in energy efficiency (energy savings for the same production level) of 13 percent across a variety of crops and basins. Water use efficiency improvement (water savings for the same yield level) was surprisingly consistent around 9 percent across crops and irrigation systems (Table 1).

Although energy savings of 20 percent or better were achieved in some cases, the goal of 20 percent in water savings was not achieved in all instances because there are practical constraints for a farm to reach the optimum water savings that may not make economic sense. Further data integration to automate by management zones would be necessary in the future.

Table 1: Energy and Water Savings Observed at the Project Sites

Sites	Pumping energy intensity (MWh/Ac-ft)	Irrigation water intensity (Ac-ft/Ton)	Energy savings (MWh/Ton)
Site #1 (Pistachio)	-4%	Alternate bearing*	-4%
Site #2 (Pistachio)	-1%	Alternate bearing*	-1%
Site #2 (Almond)	-1%	-8%	-9%
Site #3 (Tomato)	N/A	-9%	-9%
Site #4 (Tomato)	Pump changed	High soil variability	N/A
Site #5 (Alfalfa)	-24%	-9%	-31%

*Alternate bearing is a phenomenon in several fruit tree species that refers to either a heavy crop one year or low crop the next.

Source: University of California Santa Barbara, University of California Davis, and PowWow Energy

Technology Transfer and Market Adoption

The project team worked closely with the Institute for Energy Efficiency at UCSB and the Agricultural Sustainability Institute (ASI) at the University of California Davis (UCD). Faculty affiliated with UC's Cooperative Extension explained the importance of field days to show members of the local agricultural community how the technology works and addresses their concerns at demonstration in 2017 at UCD's Russell Ranch that is operated by ASI. The project team showcased crops grown under different deficit irrigation levels and achieved a reduction in farming water intensity of 16 percent. These results support the project team's thoughts that the consistent level of 9 percent water intensity reduction observed at the sites during the project is a reflection of limitations associated with human factors. Higher levels of water savings will require automation to alleviate labor constraints and irrigate fields by plant varieties or soil zones.

This successful demonstration of a new water measurement technique that does not involve any new hardware was well received as farms prepared for the implementation of SGMA. Four field days were organized overall: two near Davis and Fresno in the territory managed by PG&E and two near Ventura and Tulare in the territory managed by SCE. This directly led to a project with SCE for a pilot energy efficiency program in agriculture using the first part of the platform commercialized under the name PumpMonitor™. The California Department of Food and Agriculture also selected the PumpMonitor™ to quantify the water savings and the greenhouse gas emission reductions achieved by its Statewide Water Efficiency and Enhancement Program. Both of these events made the project team's work on cost models invaluable in gaining wider market adoption of PumpMonitor™. The project team also worked closely with growers to develop a cost model for irrigation scheduling so that it would also be valid for farms ranging in size from 20 to 20,000 acres a part of the platform that is now commercialized under the name CropMonitor™.

The project's impact on market adoption of the software-based water and energy management solution for agriculture is summarized with a before-and-after picture (Figure 4). The two maps show the number of monitored pumps (circles with different alert status: green = ok and red = alert) before the project (2014) and after the project (2018). OK and alert are pump statuses relative to the pump monitoring. The area managed by the decision support tool grew from 2,000 acres to 60,000 acres and continues to double every year.

Figure 4: Market Adoption Before the Project Started (Left) and After It Ended (Right)

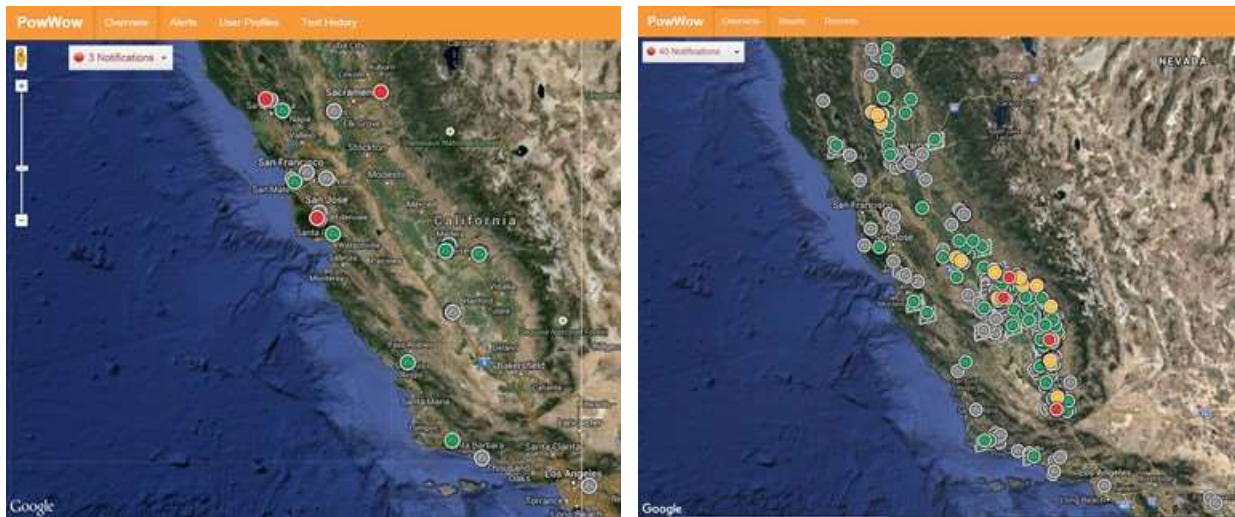

Source: PowWow Energy

Benefits to California

The technology developed in this project will benefit California's farming communities by giving them a cost-effective tool to for achieving compliance with new state SGMA regulations related to agricultural water and energy use. Increase in agricultural water use efficiency will contribute significantly to statewide initiatives for developing drought resiliency and climate change mitigation strategies. Associated reductions in energy intensity will benefit ratepayers by helping to meet state targets for increased energy efficiency, petroleum displacement, and reduction of GHG emissions.

Using this technology across 20 percent (580,000 acres) of the 2.9 million acres cultivated in California for almond, pistachio, tomatoes, and alfalfa would achieve annual savings of more than 66 gigawatt-hours and 120,000 acre-feet of water, and GHG emission reductions of nearly 19,000 metric tons of CO₂ equivalent. These values were calculated using averages from the project results of 9 percent in water savings and 13 percent energy savings. More energy savings could be achieved by coordinating groundwater recharge in wet years and deficit irrigation in dry years.

This project has already had multiple impacts for irrigation policy development across several state agencies besides the California Energy Commission, including: California Department of Food and Agriculture (measurement dashboard for Statewide Water Efficiency and Enhancement Program), UC Agricultural and Natural Resources (development of VINE network for entrepreneurship), and the Department of Water Resources (new water measurement method meeting Title 23 criteria).

CHAPTER 1:

Introduction to Water-Energy Nexus in Agriculture

The intrinsic connections between water and energy resources in California are well established. Storing, moving, and treating water account for nearly 20 percent of California's total electricity consumption and 30 percent of non-power plant natural gas consumption,¹ making consumers of electricity for water-related uses the largest electricity user group in the state. California's extensive agriculture industry is the largest water user in the state, utilizing more than 40 percent of California's total fresh water supply. Agricultural water use consumes 10 terawatt-hours (TWh) of electricity per year, which represents approximately one-fifth of all water-related electricity consumption and 4 percent of total electricity consumption in California.² Because the majority of electricity generation comes from power plants burning fossil fuels, water use in agricultural operations contributes significantly to the state's overall carbon footprint and greenhouse gas (GHG) emissions. In addition, the large amount of power consumed for agricultural water use places a strain on California's electric power grid during peak demand periods. Reducing power consumption associated with water use by the agriculture sector in California will therefore be critical to energy security and attaining the reductions in GHG emissions required by Assembly Bill 32 (Nunez, Chapter 488, Statutes of 2006).

Agricultural energy-water links are amplified during periods of drought, when reduced availability of water resources has a triple effect on the grid: 1) low stream and lake levels result in lower production from hydroelectric power stations; 2) farmers consume more power as they pump more groundwater from wells to compensate for the reduction in runoff water supplied by the state; and 3) groundwater is pumped from deeper wells due to lowering of the water table, requiring more power to pump a given amount of water. In 2014, at the peak of the 2012-2016 drought, California growers were expected to pump an additional 5 million acre-feet of groundwater from aquifers to compensate for the lack of surface water and rain, resulting in an additional \$454 million of energy costs.³ In addition to creating further economic burdens for growers, excessive groundwater extraction depletes the state's groundwater resources. It is evident that California growers must reduce their dependence on groundwater pumping for irrigation and protect their groundwater reserves, especially in light of future projections for more frequent and severe droughts resulting from climate change.

1 California Air Resources Board, 2014. First Update to the Climate Change Scoping Plan: Building on the Framework, Pursuant to AB32, The California Global Warming Solutions Act of 2006. Sacramento, CA: Air Resources Board, p. 62.

2 California Energy Commission. *Agriculture and Food Processing Research*. www.energy.ca.gov/research/iaw/agriculture.html. Accessed 12 Feb. 2018.

3 Howitt, R.E., Medellin-Azuara, J., MacEwan, D., Lund, J.R. and Sumner, D.A., 2014. *Economic Analysis of the 2014 Drought for California Agriculture*. Center for Watershed Sciences, University of California, Davis, California, p. 3. watershed.ucdavis.edu

1.1 Energy Intensity of Irrigation in California

Increasing energy efficiency is the most immediate and effective means of reducing power consumption for water-related uses. As stated in the *2011 Governor's Clean Energy Jobs Plan*, "Energy efficiency is the cheapest, fastest, and most reliable way to create jobs, save consumers money and cut pollution from the power sector."⁴ In the *2013 Integrated Energy Policy Report* and the *Electric Program Investment Charge (EPIC) 2012-14 Triennial Investment Plan*, the Energy Commission identified energy efficiency as a top priority for meeting California's energy needs and ranked it highest in the "loading order" to be used for allocating funding.^{5,6} For the agricultural sector, the California Public Utilities Commission (CPUC) has set a goal of increasing energy efficiency such that production energy intensity (for non-renewable energy sources) will be reduced by 15 percent from 2008 levels by 2020.⁷ Increasing the efficiency of energy use for irrigation has been identified as an area of specific interest in the CPUC's *Energy Efficiency Strategic Plan*, as pumping water for irrigation accounts for 80 percent of electricity use in the agricultural sector. In order to understand the energy intensity of farming in California, it is important to separate the two underlying factors: 1) the water required to grow a crop on a field in a specific climate; and 2) the irrigation system used to deliver water to the fields, which requires energy to run the hydraulic pumps.

1.1.1 Water Intensity of Farming

The water requirements of crops are relatively well understood and are explained in detail in Chapter 3. Water consumption can be reduced by applying the right amount of water to the plants at different stages of a growing season. This avoids losses from deep soil percolation and runoff. The process of a plant to capture carbon from the air for multiple biological functions is called transpiration. A plant absorbs carbon dioxide and releases water. The plant regulates the amount of transpiration by opening or closing its stomata (Figure 5). Evaporation accounts for the water lost to the air from other sources such as the soil. Evapotranspiration (ET) is a complex phenomenon that depends on the atmospheric pressure, the phenological stage of a plant, and the amount of water available in the soil. It is referred to as Soil Plant Atmospheric Continuum.

4 Brown, E.G. *Governor's Clean Energy Jobs Plan*. gov.ca.gov/docs/Clean_Energy_Plan.pdf.

5 California Energy Commission, 2013. *2013 Integrated Energy Policy Report*. Publication Number: CEC-100-2013-001-CMF, p. 1.

6 California Energy Commission, 2012. *The Electric Program Investment Charge: Proposed 2012- 2014 Triennial Investment Plan, Staff Report*. Publication Number: CEC- 500- 2012- 082- SF, p. 1.

7 California Public Utilities Commission, 2011. *Energy Efficiency Strategic Plan: January 2011 Update*. p. 47. www.cpuc.ca.gov/PUC/energy/Energy+Efficiency/eesp.

Figure 5: Transpiration Through the Stomata of a Leaf

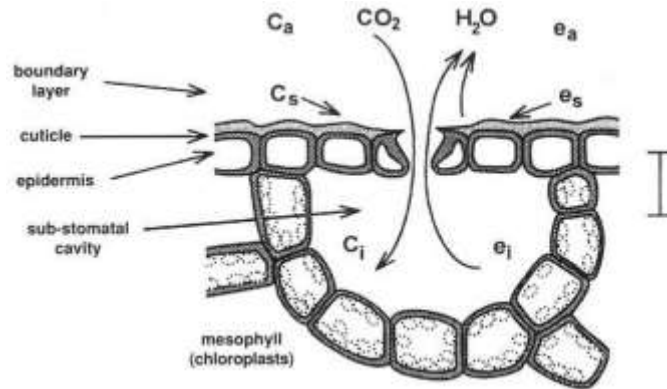

Schematic cross-section of a stoma of a leaf showing the pathway of carbon dioxide (CO₂), and water (H₂O) in the light. C_i, C_s, and C_a refer to internal, surface and ambient CO₂ concentrations; e_i, e_s, and e_a refer to internal, surface and ambient air humidity. Scale bar indicates 100 micrometers.

Source: Food and Agriculture Organization of the United Nations

At the leaf level, water use efficiency is defined as the amount of carbon assimilated divided by the amount of transpiration. At the field level, water use efficiency can be defined as the crop yield by divided the amount of water applied. The water intensity of farming is the inverse of water use efficiency, the amount of water applied divided by the crop yield:

$$Farming\ Water\ Intensity = \frac{Applied\ Water}{Crop\ Yield} = \frac{1}{Water\ Use\ Efficiency}$$

1.1.2 Energy Intensity of Pumping

The energy intensity of irrigation has been thoroughly documented,^{8,9} with the amount of energy consumed to move a certain amount of water determined by three variables:

- the flow of water (Q) in gallons per minute.
- the total dynamic head (TDH) in feet, which combines the lift of water from the well, and the discharge pressure into the irrigation system.
- the overall pumping plant efficiency (OPE) in percentage.

The relationship is the same for all pumps but the units differ depending on whether the motor is run with electricity, natural gas, or diesel. The majority of pumps in California are run with electric motors. For this Electric Program Investment Charge (EPIC)-funded project, the project team focused on agricultural pumps connected to the electrical grid. The equation for the energy intensity of an electric pump, with energy expressed in kilowatt-hours (kWh) and water expressed in acre-feet (ac-ft), is:

$$Pumping\ Energy\ Intensity = \frac{Energy}{Pumped\ Water} = \frac{1.0241 \times TDH}{OPE}$$

⁸ Irrigation Training and Research Center, 2011. *Agricultural Water Energy Efficiency*. California Energy Commission. Publication number: CEC-500-06-040.

⁹ Center for Irrigation Technology at CSU Fresno, 2013. *Irrigation Systems Water/Energy Evaluations Market and Technology Assessment*. Publication number: ET12PGE1401.

Note that OPE is for the entire pumping plant, not just the hydraulic pump. Achieving better OPE is currently subsidized by the CPUC under various pump efficiency test programs. TDH depends on the groundwater table. It is currently considered as an external factor.

1.1.3 Measurement and Verification Based on Life Cycle Assessment

It is evident that the energy intensity of farming depends on numerous factors, making it challenging to measure the amount of energy savings that can result from intentional changes to pump operation or the irrigation of a field. The staff at the Energy Efficiency Institute at University of California, Santa Barbara (UCSB) selected Life Cycle Assessment (LCA) as the framework for analyzing the impact of the decision support tools demonstrated in this project. The LCA model is available in Appendix A. LCA is a systematic set of procedures for compiling and examining the inputs and outputs of materials and energy and the associated environmental impacts directly attributable to the functioning of a system throughout its life cycle. One critical step is to define a system, whether it is farming or another part of the life cycle of food (Figure 6).

Figure 6: Life Cycle Assessment (LCA) of Food

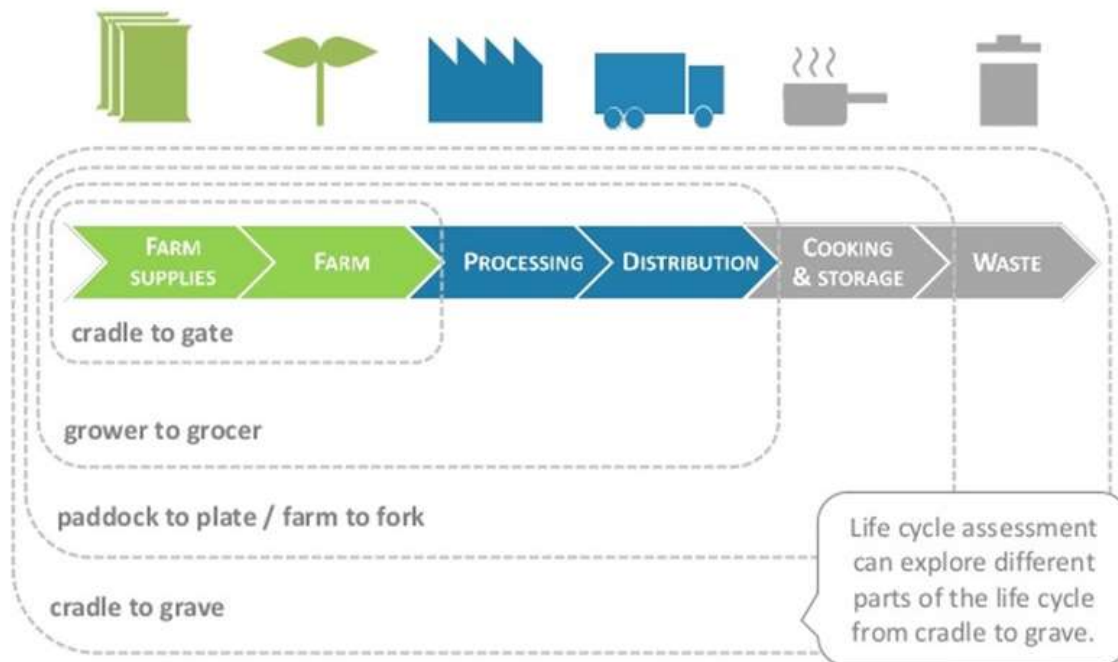

A life cycle perspective on food.

Source: Life Cycle Logic, Australia

In the context of irrigation, the project team explored the production of food from “cradle to grave”, with energy consumption as the primary input and crop yield as the output of production. The LCA functional unit is therefore the amount of energy divided by the commercial amount of crop harvested. The LCA framework is particularly effective in this study because it allows the team to analyze independently the two components of the project responsible for reducing energy usage at the farm (well pump monitoring and optimized

irrigation scheduling) and estimate their combined effect. Water is the common element. The energy intensity of irrigation per output of production is the product of the energy intensity of pumping and the water intensity of farming when the pumped water and the applied water are the same:

$$Functional\ Unit = \frac{Energy}{Crop\ Yield} = \frac{Energy}{Pumped\ Water} \times \frac{Applied\ Water}{Crop\ Yield}$$

1.2 Tragedy of the Commons

California faced the worst drought in recorded state history between 2012 and 2016. On January 17, 2014, Governor Edmund G. Brown, Jr. declared a drought state of emergency. On April 2, 2017, Governor Brown lifted the drought emergency but declared that California must continue water conservation efforts. Periods of drought are more frequent as recorded by the United States Geological Survey, California Water Science Center (Figure 7).¹⁰

Figure 7: Average Annual Runoff and Precipitation for Historic Droughts

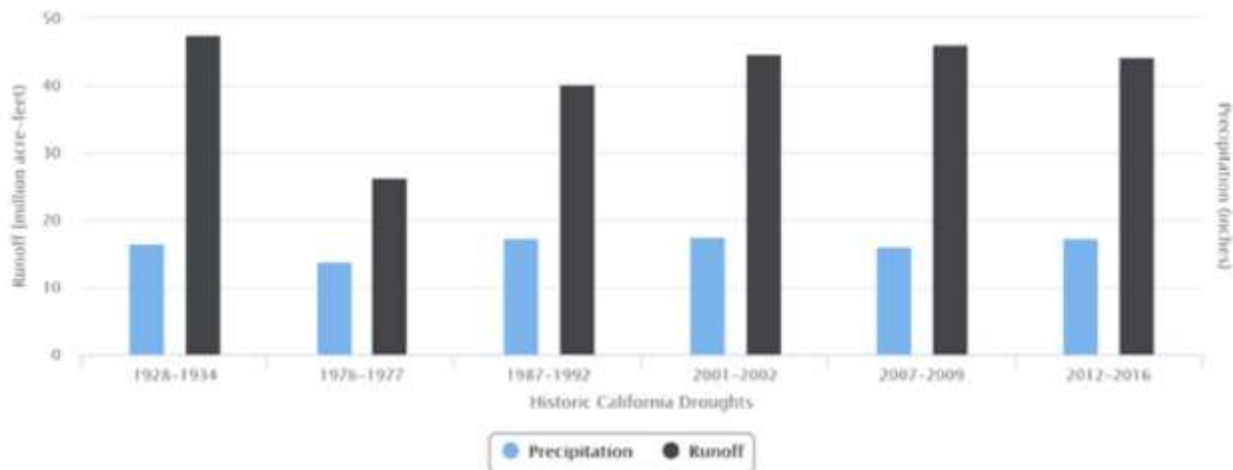

Source: U.S. Geological Survey, California Water Science Center

California’s 39 million residents experienced the deleterious effects of that drought to one extent or another, and the agricultural sector is no exception. The amount of rainfall (precipitation) and the availability of surface water (runoff) significantly affect farming operations, and growers dependent primarily on surface water to grow crops are forced to use groundwater to make up the deficit in surface water during dry years. Pumping water extensively from aquifers leads to increased energy costs and threatens long-term water reserves. Groundwater use is a good illustration of Garrett Hardin’s essay “Tragedy of the Commons”,¹¹ which focuses on herders sharing a common parcel of land on which each can graze their sheep. According to Hardin, the land could provide adequately if the number of

¹⁰ U.S. Geological Survey. *2012-2016 California Drought: Historical Perspective*. ca.water.usgs.gov/california-drought/california-drought-comparisons.html. Accessed 12 February 2018.

¹¹ Hardin, G., 1968. *The Tragedy of the Commons*. Science Magazine. 162 (3859): 1243-1248. doi:10.1126/science.162.3859.1243. PMID 5699198.

herders grazing cattle on it was kept in check through natural population control mechanisms, such as war and disease. If the numbers increased as a result of those natural population control mechanisms being overcome, the land would no longer be sufficient to support the population. Each person sharing the land, acting in self-interest, would continue to tax the resources of the commons, despite the fact that if enough people do so, the land will be damaged and unable to support them.

1.3 Sustainable Groundwater Management Act

To avoid inappropriate use of the common water use areas, the State of California had to adopt new policies. In 2014, Governor Brown signed three laws: Assembly Bill 1739 (Dickinson, Chapter 347, Statutes of 2014), and Senate Bill 1168 (Pavley, Chapter 346, Statutes of 2014) and Senate Bill 1319 (Pavley, Chapter 348, Statutes of 2014). Collectively, they are referred to as the Sustainable Groundwater Management Act of 2014 (SGMA). SGMA applies to 515 groundwater basins but contains special requirements for basins or sub-basins that the Department of Water Resources (DWR) designates as medium- and high-priority basins (127 basins, representing about 96% of groundwater extraction; Figure 8).¹²

For these basins, SGMA required Groundwater Sustainability Agencies (GSAs)¹³ to be formed by July 1, 2017. Each GSA will be responsible for developing and implementing a Groundwater Sustainability Plan (GSP) for the sustainable management and use of groundwater in its basin. GSPs will include restrictions on groundwater use, such as setting a maximum quantity of water that can be withdrawn annually from a groundwater supply without causing an undesirable result. GSAs have 3 to 5 years to develop and begin implementing their GSPs and must achieve sustainability (*i.e.*, balanced levels of pumping and recharge of groundwater supplies) within 20 years from the time of implementation. Even though GSPs will not be implemented for several years, SGMA requires groundwater elevation to be monitored to set a baseline. The common understanding is that farms must monitor groundwater extraction. The regulations to implement GSPs were approved by the California Water Commission in 2016. The GSAs are responsible for developing plans for the sustainable management and use of groundwater that must bring their groundwater basins into within 20 years of their implementation.

More information about compliance requirements is provided in Chapter 2, which reviews the accuracy of a new water measurement method developed by PowWow Energy, in collaboration with the University of California, that leverages data from smart meters used by investor-owned utilities (IOUs).

12 California Department of Water Resources, 2014. *California Groundwater Elevation Monitoring: Basin Prioritization Process: June, 2014*. Sacramento, CA: Department of Water Resources, p. 6.

13 California Department of Water Resources. *Groundwater Sustainability Agencies*. www.water.ca.gov/Programs/Groundwater-Management/SGMA-Groundwater-Management/Groundwater-Sustainable-Agencies. Accessed 12 February 2018.

Figure 8: Groundwater Basin Prioritization

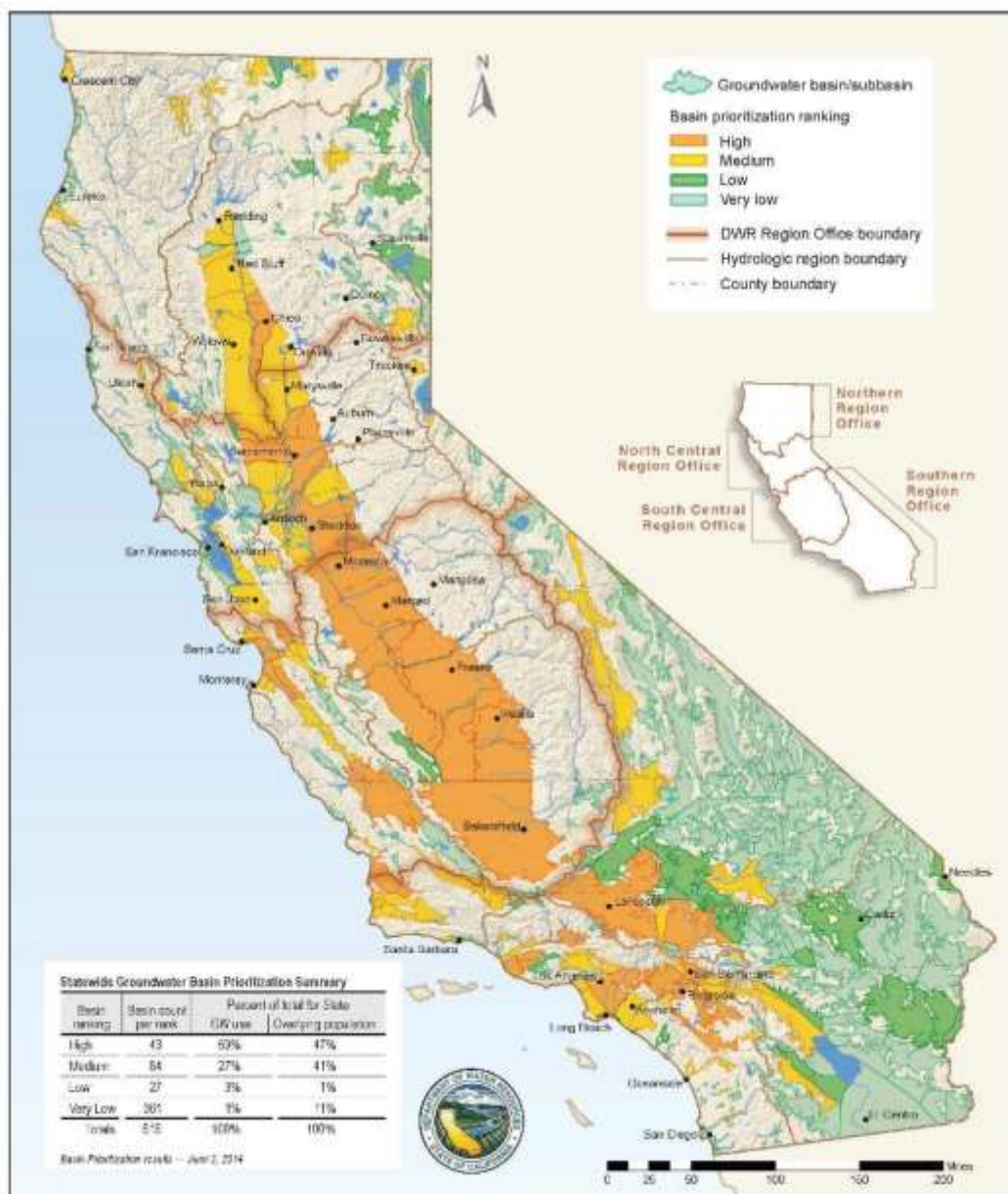

Source: California Department of Water Resources

1.4 Gap Between Groundwater Monitoring and Irrigation Scheduling

In agricultural water use, there is a notable difference between “extracted water” and “applied water”. Farms focus on the amount of water applied onto a specific field in inches, whereas the supply of water can be extracted from different sources and must be tracked in acre-feet for compliance. This may seem like a minor detail, but it is a source of complexity that makes water reporting time-consuming and disconnected from farming practices.

It is also representative of a common gap that slows down adoption of new technologies in agriculture. Growers generally spend more of their working day in the field and not necessarily in front of a computer. At the time the project started, the information from the California Irrigation Management Information System (CIMIS) was used by less than 10% of the farms.

The gap between pumping and irrigation can also put the success of new energy efficiency programs at risk. Recently, Pacific Gas and Electric (PG&E) decided to stop their low-pressure nozzle rebate program because it did not translate into energy savings. The person running the irrigation system (owner or farming staff) is often not the person maintaining the pumps (electrician or local dealer). If the operating condition is not adjusted, the energy savings do not materialize.

This project addressed the root cause of this issue by providing a simple and scalable way to measure groundwater extraction and save energy in a way that is not disconnected from irrigation practices:

- Farming staff receives a text alert in the field when a pump has an issue.
- Weekly irrigation schedules are presented in inches and pump hours.
- Water records can be downloaded in acre-feet at the end of the season by the office staff to meet new compliance requirements, such as SGMA.

As depicted in Figure 9, the software tool integrates several sources of data. The software architecture is summarized in Chapter 4. The project also provided a safety net for adopting new irrigation schedules that reduce water and energy but could put the crop at risk if not implemented carefully. Chapter 5 details how a farm can easily have access to a benchmark and set a target for the coming season using the software-as-a-service. The idea is to achieve a “win-win,” reducing water and energy consumption while maintaining or improving yield.

Figure 9: Approach to Solve the Gap Between Groundwater Monitoring and Irrigation Scheduling

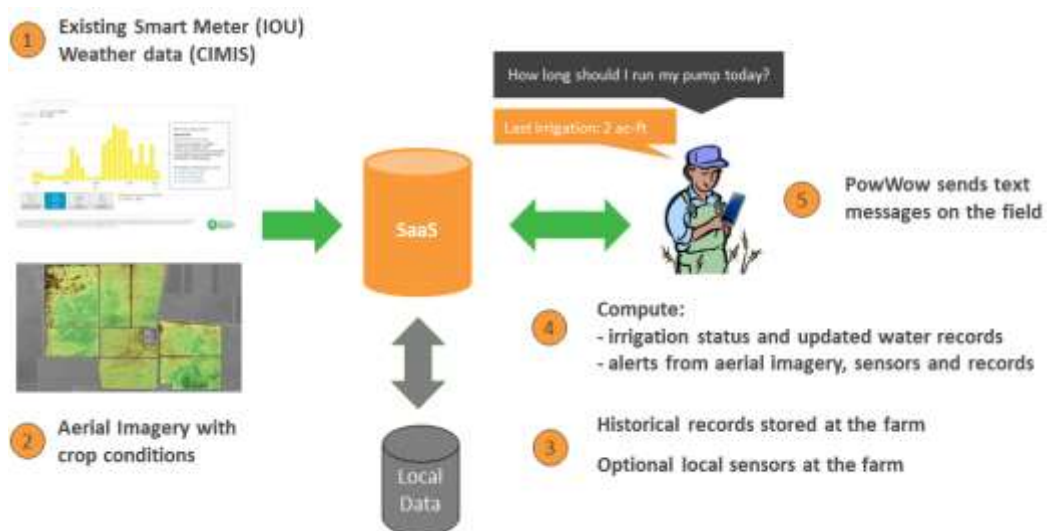

Source: PowWow Energy

In Chapter 6, the project team describes the sites selected to represent different crops grown in different geographies serviced by PG&E and Southern SCE. Each farm had a different approach to risk taking, ranging from “conservative” to “progressive”. For each site, the project team collected energy, water, and yield data for multiple seasons between 2015 and 2017.

In Chapter 7, the project team summarizes the results and discuss the potential impact on California. The project team expanded the analysis during the technology transfer activities, summarized in Chapter 8, to make sure that the new tool could be used widely by small and large farms. Power utilities, local water agencies, and farms all benefit to better manage California’s groundwater resources.

A common theme came up regularly during the outreach activities, in which the project team surveyed more than 100 farms during the project: one thing farmers do not have more of is time. In order for growers to adopt a new tool, it has to save them time and not make their daily lives more difficult. In essence, farming is a physically demanding activity that deals with many uncertainties: weather, disease, market volatility in the price of crops, and changes in the cost of farming inputs. Growers do not have the time to look at multiple Internet applications to make a decision every week. This project focused on demonstrating, at commercial scale, a decision support tool that reduces water and energy consumption on farms while also making the life of growers easier by saving precious time.

CHAPTER 2:

Groundwater Measurement Leveraging Smart Meters

It is difficult to measure pumped water volumes from energy records because the relationship between energy and water changes significantly over time. It depends on multiple factors that can vary over a growing season or within the same day. As the Irrigation Training and Research Center (ITRC) noted in a report,¹⁴ one pump test is not enough to measure water. There are several technical challenges:

- OPE varies greatly across pumps and over time.
- Water flow does not always necessarily change with a change in energy depending on the type of pump curve and the actual operating condition.
- The relationship between water and energy depends on several factors that change over time (TDH in particular). Changes in water table level and discharge pressure are common, and often systematic due to change in irrigation sets connected to same pump. Wear and tear can also cause the pump curve to change.

However, the approach of leveraging smart meters is very attractive. “The simplest and least costly answer for grower monitoring could be using smart meters and pump tests to come up with a relatively accurate measure of extraction,” noted a grower at a recent workshop to review the different methods to measure groundwater for SGMA compliance.¹⁵ Advanced Metering Infrastructure (AMI) known as “smart meters” is already in place. It consists of the physical device (Figure 10) and the telemetry infrastructure to collect and process the data every day for billing purposes. During the project, farms expressed a concern for privacy. Smart meters were collectively paid for by California ratepayers, and is under strong privacy protections to the benefit of end-users, including farms.

PowWow Energy (PWE) addressed the challenges to measure water with their patented method based on machine learning to detect pump anomalies and measure volumes of water.¹⁶ In this chapter, the project team summarizes the approach implemented by PWE and the evaluation of the water measurement accuracy with independently calibrated devices by the Center for Irrigation Technology (CIT) at CSU Fresno. The data collected were reviewed and analyzed against the accuracy requirements from the California Code of Regulations (CCR) Title 23 by the Bren School of Environmental Sciences and Management at UCSB. The full report is available in Appendix B. There are also environmental and economical advantages for farms to use PWE’s

14 Burt, C., 2017. *Using Electricity Consumption to Estimate Water Volumes Pumped from Wells*. Irrigation Training and Research Center (ITRC) at CSU San Luis Obispo. ITRC Publication No. P 17-001, 8 pp.

15 Pollock, D., 2017. *Growers express interest in groundwater monitoring*. AgAlert, the weekly newspaper by the California Farm Bureau Federation. Issue of October 4, 2017, p. 9.

16 Jerphagnon, O. *Methods to detect anomalies and to measure water usage in pumping plants using energy data*. U.S. Patent No. 9,823,156. November 21, 2017.

new method, which UCSB compared with two other types of water measurements (a mechanical meter with manual readings and a magnetic meter with a telemetry system).

Figure 10: Example of Smart Meter at a Pumping Station for Irrigation at an Almond Orchard



Source: PowWow Energy

2.1 Water Records From Electrical Data

There is an inherent relationship between the kinetic energy of the volume of water traveling through a pipe and the mechanical energy of the engine used to rotate the bowls. From the principle of energy conservation, they are equal after accounting for friction losses in the form of heat dissipation in the engine, mechanical vibrations in the mechanical shaft, and occasional turbulence in the water flow. According to the law of conservation of energy, the integral of water pumped (total water volume moved in a day) is related to the integral of power (total of energy in the same day), as illustrated in Figure 11.

Figure 11: Relationship Between Water Flow and Horsepower of a Pump



Multiple cycles of a pump representing the concept of energy conservation. The flow rate (blue line; primary y-axis) and the power use (orange line; secondary y-axis) show similar shapes over time.

Source: PowWow Energy

2.1.1 Green Button Standard

The Green Button program was launched by the White House CTO Office¹⁷ and leverages past work done by utilities in California and the National Institute for Standards and Technology (NIST). More than 50 utilities support the standard in North America.

The utilities implemented the North American Energy Standards Board's (NAESB) “REQ 21 -- Energy Service Provider Interface (ESPI) energy use information exchange standard”, which contains two parts:

- The format of the data stored by the utility and that can be downloaded by the user.
- The protocol to securely share the data with a third party if the end-user allows it.

2.1.1.1 Download My Data

Many energy providers provide access to energy use data for their customers through Internet websites. These websites provide a way for consumers to view historical use data and, in some cases, to download energy use data for further analysis. The downloaded file often uses comma-separated value (CSV) formatting and is different for each website. Green Button Download My Data (DMD) provides downloadable energy data that complies with the Green Button standard ensuring a consistent data format from all energy provider websites.

2.1.1.2 Connect My Data

Green Button Connect My Data (CMD) provides application developers an automated technique to access consumer energy information while providing consumers security. CMD requires applications to gain authorization from consumers using the Internet Engineering Task Force (IETF) OAuth 2.0 Authorization Framework standards [RFC6749] and [RFC6750]. While such authorization can be obtained in several ways, a typical method requires the consumer to provide authorization using a webpage. This results in the application gaining access to the consumer's energy data without the consumer having to provide the userid and password they use to access their energy provider's website. Once this authorization is granted, the application is able to automatically retrieve the consumer's energy data without any further involvement of the consumer. CMD greatly simplifies and improves the ability for applications to retrieve and analyze energy data beyond the capabilities of the DMD process.

2.1.1.3 Implementation by California Investor-Owned Utilities (IOU)

PWE has integrated its server with PG&E and SCE. Historically, San Diego Gas & Electric (SG&G) was the first California IOU to support CMD in 2013, and PWE was one of the first companies in the country to integrate the capability.¹⁸ PG&E supports Green Button CMD under the name

17 Chopra, A. *Modeling a Green Energy Challenge after a Blue Button*. The White House, 15 September 2015. www.whitehouse.gov/blog/2011/09/15/modeling-green-energy-challenge-after-blue-button. Accessed 12 Feb. 2018.

18 Saint John, J. *Turning smart meters into water leak detectors*. Greentech Media, 17 December 2013. www.greentechmedia.com/articles/read/turning-smart-meters-into-water-leak-detectors#gs.4qzBFmg. Accessed 12 Feb. 2018.

“Share My Data”. PWE is listed as one the companies that end-users can authorize PG&E to share their data with (Figure 12).

Figure 12: Implementation of Green Button Connect-My-Data by PG&E

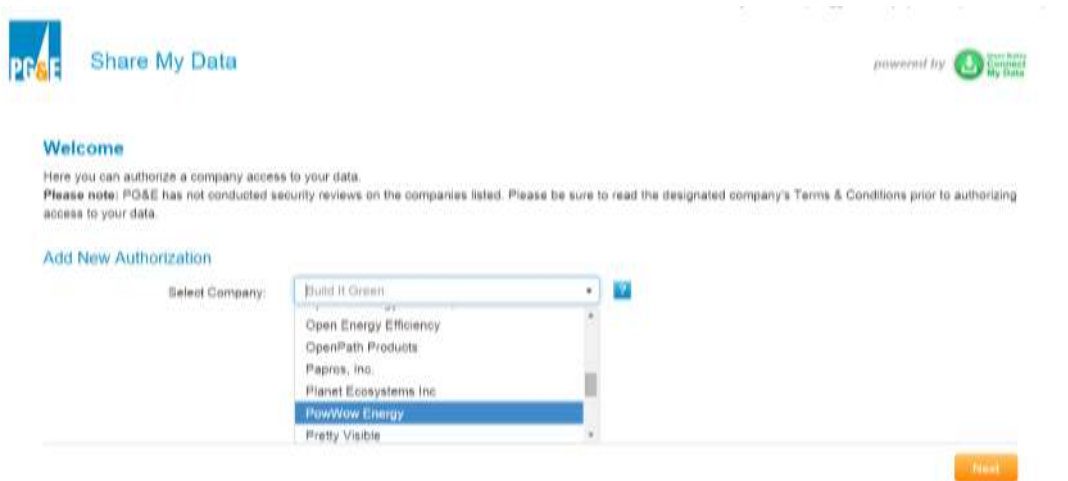

PowWow Energy is listed as an approved third-party to receive Green Button data.

Source: Pacific Gas & Electric

SCE had announced its support of CMD feature under the “Share My Data” program in 2015, but it was still in the testing phase during most of 2016. PWE first leveraged the existing DMD feature to collect energy data every day after farms signed a waiver to store their data. When CMD was finally available in 2017, PWE was one of the first applications listed on the SCE website as depicted in Figure 13.

Figure 13: Implementation of Green Button Connect-My-Data by SCE

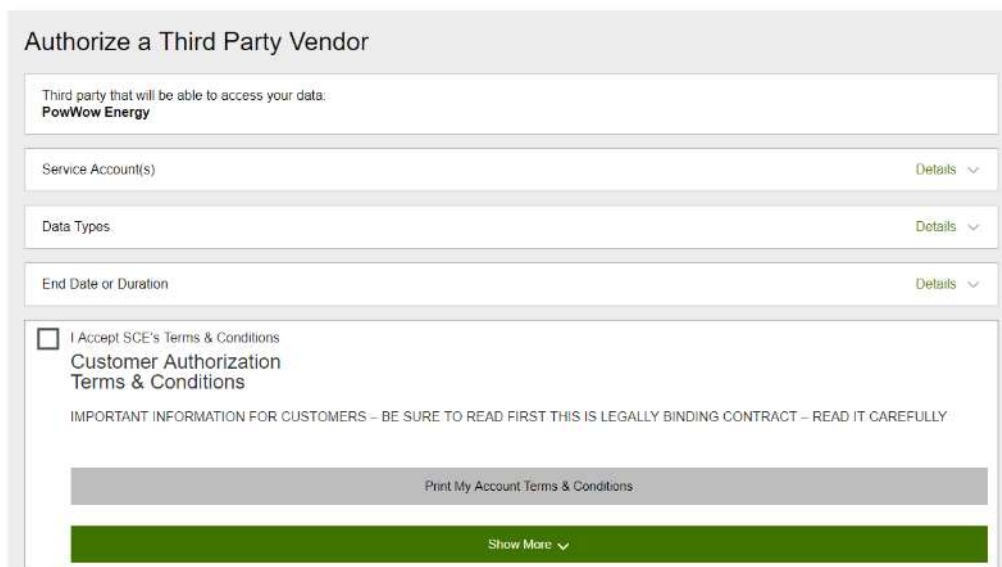

End-user selected PowWow Energy as third-party to receive data.

Source: Southern California Edison

2.1.2 Pump Efficiency Test Programs

Historically, IOUs in California have provided pump efficiency test services with staff members who developed a trust relationship with growers. The hydraulic team at SCE continues to do so, whereas other utilities leverage the Advanced Pump Efficiency Program (APEP) established by PG&E in collaboration with CSU Fresno. Certified pump testers are available to test pumps across California.¹⁹ They follow detailed procedures and each metric is entered following best practices using devices that are regularly calibrated.

Both programs are sponsored by the CPUC and use the same concept. Farms are offered pump tests to assess the energy efficiency of the pumping station and may be eligible if repairs can save energy beyond normal wear-and-tear that would require a repair anyway. There is no “free rider”. The OPE of a single speed pump (SSP) follows the equation below, where Q is the water flow in gallons per minute, TDH is the total dynamic head in feet, and HP is the input horsepower:

$$OPE = \frac{Q \times TDH}{3960 \times HP}$$

Recently, PG&E and SCE decided to provide a rebate for installing Variable Frequency Drives (VFDs) to maintain high efficiency across a large range of operation. As the price goes down, more farms are operating Variable Speed Pumps (VSPs) thanks to the installation of a VFD.

2.1.3 Single-speed Pump

For a SSP, the relationship between energy and water use is set by OPE, which is a function of the pump performance curve and the TDH. Each pump curve is different. Pumps are usually installed to work at their maximum OPE. However, the operating condition can change over time. As depicted in Figure 14, the operating condition characterized by head (H) and flow (Q) can vary from design point (black) to other conditions with less-than-optimum OPE (red and green).

Figure 14: Single Speed Pump Curve

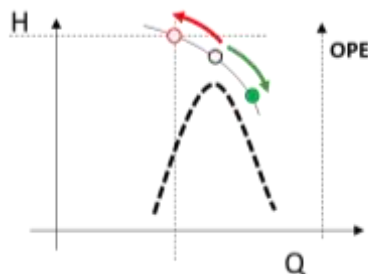

The motor adapts to the pump performance curve. Head (H) and OPE vary with water flow (Q).

Source: PowWow Energy

¹⁹ Advanced Pump Efficiency Program. *Advanced Pumping Efficiency Program (APEP) - Pump Testers*. www.pumpefficiency.org/pump-testing/pump-testers. Accessed 12 Feb. 2018.

The current version of the PWE algorithm recommends a 3-point pump test for to cover large range of water flow. Pump test results are entered on the web portal (Figure 15).

Figure 15: PowWow Web Application With Pop-up “Pump Tests” Tab

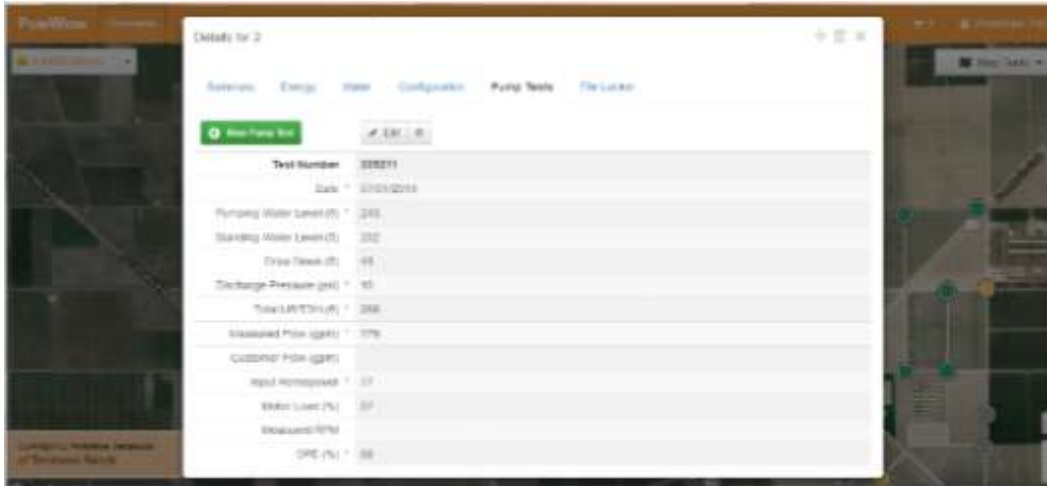

Source: PowWow Energy

Farming staff can enter the results of the certified pump test including: pumping and standing water levels, discharge pressure, water flow, input horsepower, and OPE.

2.1.4 Variable-speed Pump

For a VSP, the relationship between water and energy use is not set by the pump performance curve. The rotation per minute (RPM) is adjusted by the VFD to change the pump curve so OPE stays high even if the pump is used at a different flow rate. The operating condition is set along the system curve and not the pump curve in this case (Figure 16).

Figure 16: Variable Speed Pump Curves

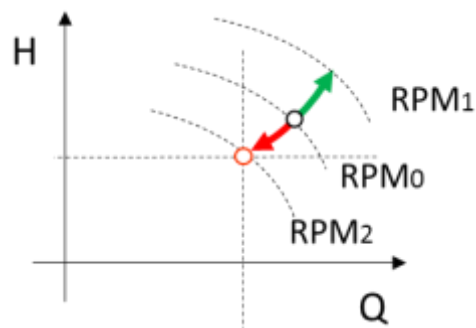

Source: PowWow Energy

The VFD changes the RPM of the drive motor and the water flow (Q) to adjust the new head (H) due to a change in discharge pressure or pumping water level.

PWE requires a minimum of two test points at high and low RPM to calibrate water measurement from energy data on VSP. It is important to set the right type of pump (SSP or VSP) in the PWE web portal. The algorithm for VSP case is different from SSP case.

2.2 Accuracy Analysis for CCR Title 23 Certification

The certification letter of the new water measurement method is available upon request. This section details the accuracy requirements, and the result of the Measurement & Verification carried out under Task 2 and Task 7 of the project.

2.2.1 New Surface and Ground Water Monitoring Requirements

On January 19, 2016, the State Water Board adopted an emergency regulation for measuring and reporting water diversions under Senate Bill 88 (SB-88). SB-88 set expectations for both the accuracy of measurement devices as well as the monitoring frequency of the device or method used to measure water.²⁰ Requirements for surface water diversion are listed in Table 2.

Table 2: Required Measurement Accuracy and Monitoring Frequency for SB 88

Type of Diversion (af = acre-feet)	Installation Deadline	Required Accuracy	Required Monitoring Frequency	Qualifications For Installation And Certification
Direct Diversion ≥ 1,000 af/year	January 1, 2017	10%	Hourly	Engineer/Contractor/Professional
Direct Diversion ≥ 100 af/year	July 1, 2017	10%	Daily	Engineer/Contractor/Professional
Direct Diversion > 10 af/year	January 1, 2018	15%	Weekly	Individual experienced with measurement and monitoring

Source: California Water Boards. State Water Resources Control Board

Similarly, the California Water Commission approved in May 2016 a framework for monitoring groundwater extraction²¹ for each high-medium priority basin to have a GSP in place by 2020 or 2022. The GSP must (1) define the existing basin setting (hydrologic models and water budget), and (2) set forth a plan to maintain a sustainable groundwater supply with no ‘undesirable results’ by 2040. The California Department of Water Resources (DWR) also defined a list of undesirable results as sustainability indicators that include: chronic lowering of groundwater levels, significant reduction of groundwater storage, significant seawater intrusion, significantly degraded water quality, significant land subsidence, and significant depletion of interconnected surface water to cause adverse impacts.

²⁰ State Water Board. *Information on Senate Bill 88 and Emergency Regulation for Measuring and Reporting the Diversion of Water*. California Water Boards, State Water Resources Control Board. 21 Mar. 2016. www.waterboards.ca.gov/waterrights/water_issues/programs/measurement_regulation. Accessed 12 Feb. 2018

²¹ State Water Board. *Title 23 of California Code of Regulations. Waters, Division 2. Department of Water Resources, Chapter 1.5. Groundwater Management, Subchapter 2. Groundwater Sustainability Plans*. www.water.ca.gov/groundwater/sgm/pdfs/GSP_Emergency_Regulations.pdf. Accessed 12 Feb. 2018.

If a groundwater basin’s sustainability indicator exceeds a minimum threshold, GSAs are equipped with the authority by DWR to enforce regulations. While no GSPs have been implemented yet, it is reasonable to expect GSAs to require farms to report on their groundwater use. They may also set maximum allocations. GSAs are actively exploring large-scale solutions to measure water.

2.2.2 Data Collection at 20 Pumps Measured Across Six Groundwater Basins

The project team collected water measurements from 20 pumps across six water basins in California (Figure 17). In addition to geographical diversity, the project team chose a relevant sample of pumps in California according to the following factors:

- Type: single speed (SSP) and variable speed pumps (VSP).
- Utility: PG&E and SCE.
- Application: deep well for extraction or booster for application.
- Impact of variation of water table and discharge pressure: horsepower, water flow, and total head are related via pump performance curves.

Figure 17: Location of the Verification Tests to Measure the Accuracy of PWE System

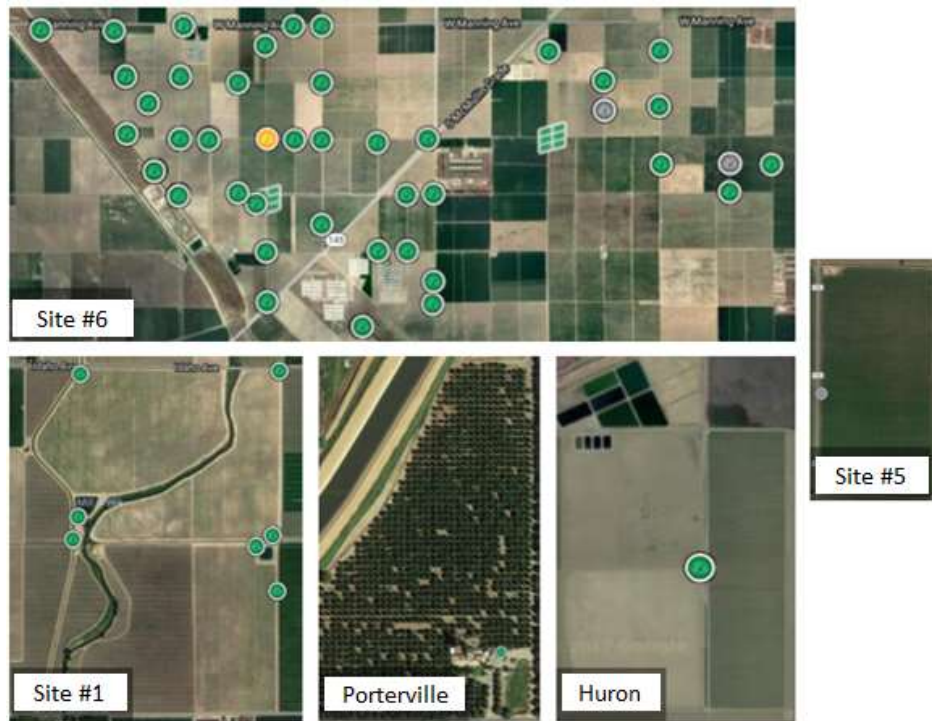

Water measurements were taken in Fresno, Kings, Santa Barbara, Tulare, and Yolo counties.

Source: PowWow Energy

The project team compared the measurements calculated by the PWE algorithms from smart meter data with “ground-truth” measurements performed with independently calibrated devices. Magnetic meters were selected for continuous data collection to assess accuracy over longer periods of time (Figure 18). Acoustic meters were selected for their portability to

measure any pumping station over a shorter period of time. Some pumping stations had multiple outputs and multiple meters were used. This is another advantage of the new measurement method to measure older pumping stations that do not have enough space to install one water meter at the source and would need to be retrofitted to comply with the new regulations.

Figure 18: Magnetic Meters Installed at Two Pumping Stations at Site #6 in Helm, California



Magnetic meters from Seametrics were installed with a telemetry station for continuous measurement of flow (gpm), discharge pressure and water table (feet) along with energy data from the smart meter (kWh). The installation on the left is for a VSP; the installation on the right is for a SSP.

Source: PowWow Energy

For this study, the project team randomly choose one day to measure a full day (midnight to midnight) for a sample of $n = 20$ pumps (15 SSP and 5 VSP). The total number of days tabulated was 69, and the results were shared with the Measurement & Verification lead (UCSB). Data were logged on the server of the telemetry vendor (WiseConn) for the long-term stations. The data were logged by the device (Figure 19) and downloaded from a smart phone via email.

Figure 19: Acoustic Meters Temporarily Installed at One Pumping Station During the Project



Magnetic meters from Seametrics were installed with telemetry for continuous measurement.

Source: PowWow Energy

2.2.3 Statement of Verification of PWE Method by Bren School of Environmental Science and Management at UCSB

The hypothesis is that the accuracy of tests will be below the goal of $\pm 10\%$ error according to California Code of Regulations Title 23, Division 3, Chapter 2. The set of data gathered during the project illustrates that the PWE algorithm is capable of measuring water from a wide range of pump nameplates, pump test types, pump configurations and pump operating conditions.

Table 3: Statistical Results of the PWE Algorithms From the 69-Measurement Dataset

Variable	Quantity
Mean Error	4.02%
Median Error	3.61%
Standard Deviation	2.78%
Mean + 2 Std. Dev. (95%)	9.57%

Source: University of California, Santa Barbara

The data suggests that error is likely to be under 10% if pump tests are properly administered and recorded. The median error is 3.6% and the standard deviation of 2.8%, as listed in Table 3. This study has also shown that estimation errors do not differ significantly between VSP and SSP configurations, and that the error spread has decreased in each of the three algorithm releases used during the project (Figure 20).

Figure 20: Boxplot Comparison of the Three PWE Algorithm Versions Tested During the Project

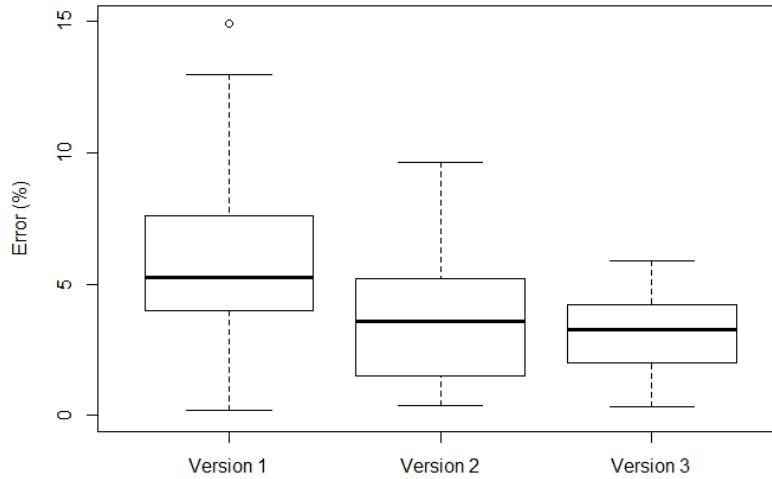

Only 12 pumps were relevant because they need to have the same ground-truth data for each version.

Source: University of California, Santa Barbara (Appendix A)

In cases where the pump test does not cover an operating HP for a pump, for example when a pump is used at low efficiency or when a pump starts to cavitate and should be repaired, PWE sends a text alert to the growers in the field to let them know that the pump needs attention and that the PWE measurement method may be inaccurate. This is a unique trait of the PWE measurement method, which allows for better maintenance of measurement methods compared with traditional solutions (magnetic or mechanical devices).

The PWE method also has its limitations. This method relies on accurate pump tests. During this experiment, consultation with one of the APEP certified pump testers revealed that three of the pump tests PWE purchased likely had incorrect data entered in them. PWE should aim to utilize their expertise in machine learning to develop an algorithm to check the accuracy of pump tests. If a pump test is entered incorrectly, it can cause the PWE algorithm to estimate results with a high error. Another limitation is that PWE (like mechanical and magnetic meters) cannot provide water estimation for all pump configurations (Figure 21). The current algorithm cannot estimate total water volume pumped on meters shared with solar arrays, meters that have multiple pumps, or most surface water lift pumps.

Figure 21: Providing 100% Monitoring Coverage for SGMA With Various Metering Methods

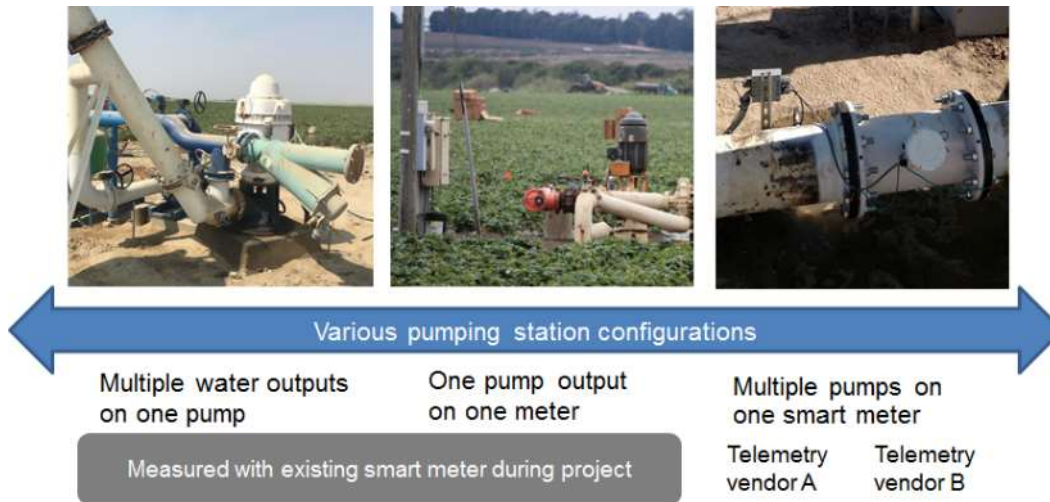

Method with smart meter is only method to measure water at old pumping stations with multiple outputs and no place to install a meter. Multiple pumps connected to the same smart meter benefit from separate water meters on each pump with a telemetry station. All the data sources can be integrated in software.

Source: PowWow Energy

As a result, PWE is working on improving their algorithms to accommodate new configurations with future testing: pump and one appliance, one well pump and one booster pump, one well pump and one lift pump, or two booster pumps connected to the same meter. PWE has also integrated on its software platform data from existing water meters to provide 100% coverage for regulatory compliance (Figure 21). Two telemetry vendors were integrated at site #6.

2.3 Comparison with Other Water Measurement Techniques

It is very difficult to accurately and economically measure water on a commercial scale like a farm. Unlike irrigation districts, many farms do not currently have measurement infrastructure in place that meets the new regulatory standards, which means they will be required to invest in new equipment. Hence, there is a need for new forms of measurement that will not demand high investments and provide the required level of performance. This document compares three different forms of metering that can meet the legislation standards for measurement: a mechanical flow meter with manual readings, a magnetic meter with a telemetry system, and a smart meter using PWE's method to convert energy records into water records. It is important to understand the costs and benefits associated with each different technique.

This section summarizes the results of the study by UCSB that analyzed each of the three systems under the lens of environmental impacts, cost, ease of use, and statistical accuracy.

2.3.1 Mechanical Meter with Manual Readings

Installation of the mechanical bolt-on-saddle flow meter (Figure 22: Bolt-on-Saddle Mechanical Meter) typically requires the aid of a trained professional. A quote from McCrometer²² stated

²² McCrometer, 2016. *Quotation for 6" M0300 bolt-on-saddle mechanical flow meter.* Quote received on 11/8/2016. Quote number: 148086.

that they would need to visit the site to measure the pipes, perform cable run evaluations, install the meter, and check that everything is running properly. A 6-inch meter must be installed at least 30 inches downstream from any obstruction, in a pipe that has a full flow and no swirling of water. Water swirling can be caused by centrifugal sand separators or two elbows in different planes. The flow of the water in the pipe and the maximum pressure must be known to select the proper meter to install. An interesting clause in the installation contract states that the buyer will, “provide McCrometer employees with all Personal Protective Equipment (PPE) and information and training required under applicable safety compliance regulations and Buyer’s policies.” Additionally, the buyer will pay the McCrometer employees a standard hourly rate to attend necessary safety classes for work on a given property. McCrometer offers a daylong service that includes installation and training. The installation can also be done by local contractors. Establishing water measurement using a mechanical meter is classified as “difficult” because installation likely requires multiple visits from a trained professional.

Figure 22: Bolt-on-Saddle Mechanical Meter



Source: McCrometer

Accuracy estimation was taken from the spec sheet for the 6” McPropeller bolt-on-saddle flowmeter M0300 online.²³ The sheet specifies that accuracy is $\pm 2\%$ throughout the full range and $\pm 1\%$ on reduced range, with $\pm 0.25\%$ or better repeatability. Accuracy of these mechanical meters is only guaranteed when the flow in the pipe is totally full and there is no swirling of water. The proper flow must be known for accuracy to be maintained. Typically, the meter is accurate to a range of 15:1 for the maximum flow and the minimum flow. During the project, the project team gathered data on field accuracy and revealed an error range of 0% - 27%, with an average of 10%. There was one outlier recorded at 80%; the meter was likely broken and requires repair.

2.3.2 Magnetic Meter with Telemetry System

Once a location is selected where the pipe will be full when water is running, a flat compressible gasket must be installed on both sides of the meter (Figure 23). Special instructions are required for installation on metal vs. plastic pipes. Once the meter is installed, a telemetry system can be added to the setup. The magnetic meter is equipped with an option to have a power input and pulse output for a telemetry system. A communication gateway can

²³ McCrometer. *Specification sheet for 6” McPropeller Bolt-on Saddle Flow Meter*. www.mccrometer.com/asset-get.download.jsa?id=52003821449. Accessed 12 Feb. 2018.

be easily installed on the magnetic meter for storage and transmission of data. The difficulty of using a magnetic meter for water measurement is classified as “moderate” because it requires a visit by a trained professional for installation and, potentially, a visit by a separate professional for training and installation associated with the telemetry system.

Figure 23: Magnetic Meter



Source: Seametrics

The primary accuracy estimation was taken from the Seametrics AG2000 spec sheet.²⁴ Accuracy is claimed to be $\pm 1\%$ of the reading for flow between 10% and 100% of max flow, and $\pm 2\%$ of the reading for flow from cutoff to 10% of max flow. When a pipe is not completely full of water, it can be difficult for magnetic meters to measure the water flow. A 10” Seametrics AG2000 magnetic flow meter was put through calibration at Fresno State Center for Irrigation Technology (CIT). Twenty flow readings were taken and compared against CIT system, which is calibrated to be 99.5% accurate. When compared with the CIT system, error ranged from -1.89% to -0.05%, with a mean error of -1.19%. This confirms that the meter is within the error bounds stated on the spec sheet. Interestingly, the magnetic meters measured less water at every single flow rate tested relative to the mechanical meters and the PWE method.

2.3.3 PWE Method Leveraging Smart Meters

There is no hardware installation necessary because the PWE solution functions using existing infrastructure. Using the PWE method to make water measurements is classified as “easy” because the only necessary on-boarding requirements are performing a pump test on the well or booster and inputting utility account information on the web application.²⁵ The accuracy of the PWE algorithm was relatively unknown at the beginning of the project and was thoroughly tested as described in Section 2.2.

2.3.4 Comparison of Water Measurement Accuracy

The reading error associated with the three meters in this analysis is presented in Table 4. Values for the mechanical and magnetic meter come from lab rated error in spec sheets, which may vary in the field. PWE error estimation was completed by PWE employees through numerous field tests, and verified independently by UCSB.

²⁴ Seametrics, 2016. Specification sheet for *AG 2000 8” Magnetic Flow Meter*. Available online at: <http://www.seametrics.com/product/ag2000-magnetic-flow-meter>.

²⁵ PowWow Energy. *Pump Monitor™* web service. www.powwowenergy.com. Accessed 12 Feb. 2018.

Table 4: Summary of Accuracy Associated with the Three Water Measurement Methods

Meter	Vendor specifications	Lab and field errors during project
Mechanical meter	$\pm 1-2\%$ ¹	$\pm 1-25\%$
Magnetic meter	$\pm 1-2\%$ ¹	$\pm 1-4\%$
PWE solution	$\pm 1-10\%$ ²	$\pm 1-10\%$

¹ These are lab rated errors. Field error is often greater without proper management.

² 95% of sampled error (n = 69) fell within this range of error (sample mean = 4.1, std. dev. = 2.78%).

Source: PowWow Energy and University of California, Santa Barbara

While many systems are calibrated to maintain minimal water measurement error in a laboratory environment, these error ranges often increase in the field. PWE gathered data comparing the flow rates of installed mechanical meters and the flow rates measured by APEP certified professional pump testers. The average error comparing the customer-installed meters to the pump tester readings was around 10% (Figure 24). This is an observed example where the field-measured error (0%-25%) is much higher than the lab rated error (1-2%).

Figure 24: Comparison of Three Systems for Measuring Groundwater Extraction

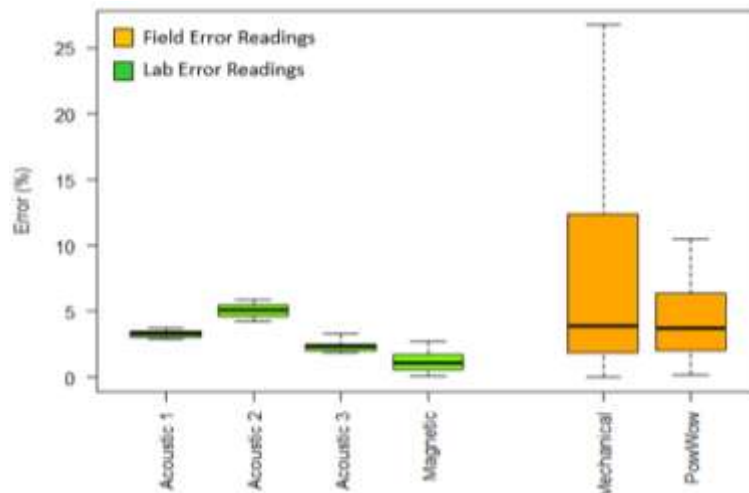

Boxplot distribution of water measurement error of acoustic and magnetic meters used in the CIT lab (green), and of mechanical meters and electrical meters with PWE algorithms in the field (orange). The plot shows the median, the middle 50% of data, and 100%-tile range. This graph does not show calculated outliers. There was one outlier for the mechanical meter at 80% error.

Source: University of California, Santa Barbara (Appendix A)

One of the principal factors that causes increased error is the fact that each pump is uniquely configured, and configurations do not always offer ideal conditions for meters. Water turbulence, cavitation, unclean pipes, and changes in pressure all occur often in pumping systems and have the potential to increase error of a meter system. Additionally, lack of proper maintenance can compound the error. The PWE system should maintain rated error throughout the season, unless there are changes to the operating conditions that are not covered by the most recent pump tests. This could include damage or wear and tear on the pump, change in

the water table, or change in pressure. As a result, a pump test is recommended every two years or after a major repair, such as replacing the bowls of the hydraulic pump.

2.4 Environmental and Economic Impact

When comparing the environmental and economic impact of the three water measurement systems, it is essential to account for the impacts over the entire life of the product and to ensure that all systems being compared are equal. To accomplish this task, UCSB selected the LCA methodology to thoroughly compare the three systems throughout the entire product lifecycle. The functional unit is defined as the reporting of annual volume of water pumped at a farm using a meter with at least 90% accuracy, and its transmission to the regulating agency.

The results from the comparison are summarized in Table 5. The PWE solution has the lowest environmental impact because the smart meter is already in place and it has the easiest logistics associated with use. There was not enough available data on the telemetry unit and data storage to estimate the environmental impacts of the magnetic meter. The mechanical meter and the PWE solution have comparable costs over five years, while the magnetic meter has a higher cost by a factor of three.

Table 5: Comparison of the Environmental and Economic Impact of the Three Measurement Systems

Variable	Mechanical Meter	Magnetic Meter	Smart Meter + PWE
Environmental Impact (kg CO2 eq)	36.65	N/A	0.48
Economical Impact (USD)	\$638	\$2,497	\$790
Ease of Use (Qualitative)	Difficult/ Moderate	Moderate/ Easy	Easy

Cost was estimated from quotation for small volume of 2-5 units provided by the vendors for a period of operation of 5 years. It includes installation, use, and reporting of weekly water data to the state.

Source: University of California, Santa Barbara (Appendix A)

CHAPTER 3:

Irrigation Strategies for Annual and Perennial Crops

Long standing irrigation practices based on traditions can sometimes come in the way of adopting new irrigation tools or strategies. This reflects growers' dedication to the land and intimate knowledge of the crops. However, the question remains: is it possible to do better? Data-based irrigation strategies can help justify the adoption of new irrigation schedules that could save water or improve yield. The main goal of irrigation scheduling is to define the adequate amounts of water to apply to cropped fields with the proper irrigation timing to avoid the occurrence of water stress (deficit and excess) during the crop cycle.

In this chapter, the project team reviews a number of rational and partial irrigation techniques based on information that can be collected and analyzed with modern technology tools. Evaporation and transpiration (ET) are the fundamental mechanisms by which a plant grows, matures and also adapts daily to its environment due to climate variability. ET helps quantifies "how much water is needed". Rational irrigation scheduling also requires irrigation managers and irrigators to know when to start irrigation, not just the amount of water used by the crop since the last irrigation or rainfall event. A number of sensors at the farm can help in refining irrigation scheduling by identifying when irrigation should start.

The project team also reviewed partial irrigation strategies that should considered and pursued during periods of limited water supply or to achieve specific quality targets of crop production. Different crops have different sensitivities and tolerances to water deficit during their various growth and production stages. A good understanding of the crop's yield responses to water is needed to successfully implement a partial irrigation strategy. Plants respond to water stress via both molecular and physiological mechanisms, which impact the plant's photosynthetic capacity. Water stress induces reduction of leaf water potential and partial closure of stomata. This reduces carbon dioxide assimilation by leaves that, in turn, affects plant growth and overall productivity. In addition, other adaptation mechanisms may also be involved, such as osmotic adjustment to increase stress tolerance. This justifies trials during multiple seasons.

Several research studies have been conducted on partial irrigation strategies and their implementation in commercial field conditions. According to Fereres and Soriano (2007),²⁶ managing water deficit during certain periods of the crop season could help not only in lowering the production costs but also in saving water, maintaining crop quality, and keeping nutrients and pesticides within the root zone for plant uptake. However, prior to implementing partial irrigation across all crops, an in-depth understanding of benefits and adverse impacts of water limitations is required. This chapter describes the principles and applications of rational and partial irrigation scheduling for four major California crops considered in this project:

²⁶ Fereres, E. and Soriano, M. A., 2007. Deficit irrigation for reducing agricultural water use. *Journal of Experimental Botany*, 58(2), 147-159.

almond, pistachio, processing tomato and alfalfa. The project team members from the University of California, Davis (UCD) led the efforts to gather and present this information.

3.1 Rational Irrigation Based on Evapotranspiration (ET)

Rational irrigation scheduling is not meant to replace the experience that growers have accumulated over the years. Growers use their own “sensors” -- their eyes, ears and fingers -- and direct knowledge of their lands and crops is invaluable because each field is different. However, data-based irrigation scheduling provides a systematic and objective approach to improve the efficient use of water in irrigated agriculture while limiting the risk of undesired effects on a crop by consistently monitoring the field. Further details and examples of calculations are provided Appendix C authored by UCD and The University of California Division of Agricultural and Natural Resources (UC-ANR).

3.1.1 Irrigation Scheduling Based on ET

Accurate estimation of crop water use is necessary to determine the amount of irrigation water to apply to crop fields throughout the crop season. Quantifying the crop ET since the last irrigation or rainfall event represents the basic information needed by growers to implement a rational irrigation schedule. Scheduling entails the following steps:

1. Observe water use frequently.
2. Start irrigation to compensate for water used for ET, and other losses in the system.
3. The duration is based on the target amount of water and the application rate.
4. Predict the next irrigation based on ET forecasts or actual ET measurements.

3.1.1.1 Reference ET

For well-watered crops under optimal agronomic conditions, the crop evapotranspiration (ET_c) occurs at its “potential” rate and can be estimated as follows:

$$ET_c = K_c \times ET_0$$

Where K_c is the crop coefficient (dimensionless) and ET_0 is the evapotranspirative demand by the atmosphere, or reference evapotranspiration (inches or mm per day).

Reference evapotranspiration represents the amount of water lost from a reference surface, either grass (ET_0) or alfalfa (ET_r), when water is not limited. It depends upon different factors:

Weather parameters: net radiation, air temperature, wind speed and relative humidity

Plant factors: root depth, canopy density, canopy height, and growth stage

Different methods and equations have been developed to estimate ET_0 on the basis of different variables. The FAO-56 Penman-Monteith equation is the most widely used method.

3.1.1.2 Crop Coefficient

Crop coefficients (K_c) are adjustment factors relating the ET of a specific crop with that of the reference crop (ET_0) under the same micro-climatic conditions. For annual crops, Allen *et al.*

(1998)²⁷ defined K_c values for four crop stages, *i.e.*, initial, crop development, mid-season, and late season stages as illustrated in Figure 25. Snyder *et al.* (2016)²⁸ and Ferguson *et al.* (2005)²⁹ reported K_c values commonly used in California for scheduling irrigation for processing tomatoes, alfalfa, pistachios and almonds (Table 6).

Figure 25: Constructed Crop Coefficient Curve for Different Stages of Plant Development

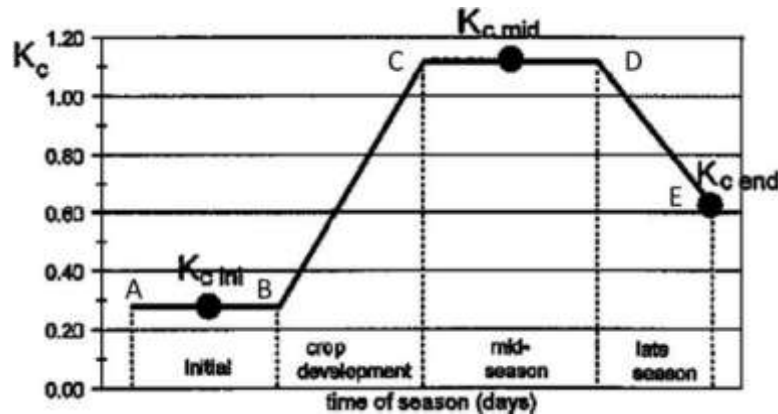

Source: Allen *et al.* (1998)

Table 6: Crop Coefficients (K_c) for Processing Tomatoes, Alfalfa, Almonds and Pistachios

Crop coefficients	Tomatoes ^a	Alfalfa ^a	Almonds ^a	Pistachios ^b
K_c (B)	0.33	1	0.55	0.54
K_c (C)	1.1	1	1.15	1.14
K_c (D)	1.1	1	1.15	1.40
K_c (E)	0.65	1	0.65	0.60

Source: Snyder *et al.* (2016), Ferguson *et al.* (2005)

Some of the crop coefficients in Table 6 are significantly greater than 1. This means that the rate of evapotranspiration is higher than a well-irrigated field completely covered by grass. During the project, the project team experienced lower K_c values during the project. K_c values must be periodically updated as farming practices and climate conditions change. This is currently done by UC ANR for pistachio. The results of the study show that canopy cover and light interception at the main drivers of crop ET. Therefore, farms can adjust crop coefficients based on the canopy size.³⁰ An example of curve is given in Figure 26 for fruit and nut trees.

27 Allen, R.G., L.S. Pereira, D. Raes and M. Smith, 1998. *Crop evapotranspiration: guidelines for computing crop water requirements*. Irrigation and Drainage Paper n. 56. FAO, Rome, Italy, 300 pp.

28 Snyder, R.L. Orang, M., Bali, K. Eching, S. and Zaccaria, D., 2016. *The Basic Irrigation Scheduling Manual*. http://biomet.ucdavis.edu/irrigation_scheduling/bis/BIS.pdf

29 Ferguson, L., Beede, R.H., Freeman, M.W., Haviland, D.R., Holtz, B.A. and Kallsen, C.E., 2005. *Pistachio Production Manual*. Fruit and Nut Research and Information Center, 4th ed. University of California, Davis, CA.

30 Schwankl, L.J., Prichard, T.L., Hanson, B.R., and Elkins, R.B., 2007. *Understanding your Orchard's Water Requirements*. Publication number 8212, University of California Division of Agriculture and Natural Services. Oakland, CA, 10 pp.

Figure 26: Comparison Between Shaded Area, ET, and Mature Trees

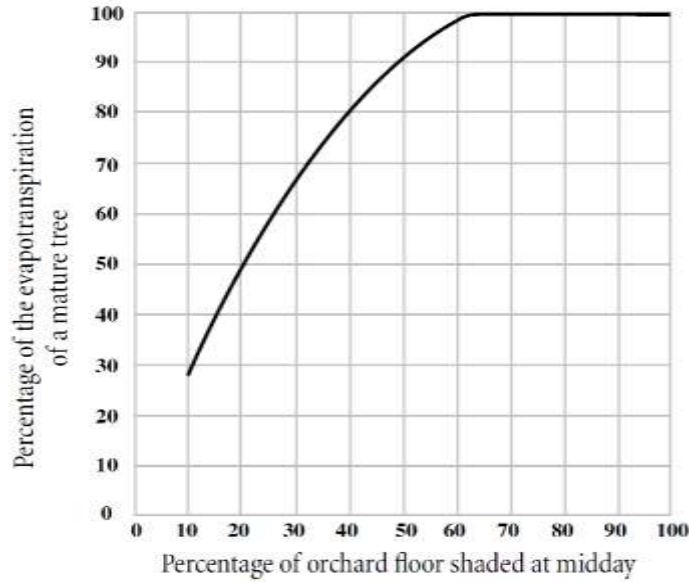

Relationship between the percentage of shaded area at midday (canopy cover) and the percentage of evapotranspiration (crop coefficient) compared to mature trees.

Source: Schwankl *et al.* (2007)

3.1.1.3 Irrigation Water Requirements

Crop ET represents the water used from a cropped surface in a given period of time. The crop water needs can be calculated from the soil-water balance in the root zone using this equation:

$$I_n = ET_c - P - G_w - \Delta SW + RO + D_p$$

where I_n is the net irrigation (inches or mm), ET_c is the crop evapotranspiration (inches or mm), P is the total precipitation (inches or mm), G_w is the capillary rise of water (inches or mm), ΔSW is the change in soil water storage in the crop root zone (inches or mm), RO is the surface runoff (inches or mm) and D_p is the deep percolation from the root zone.

Effective precipitation (P_e) is the fraction of rainfall that infiltrates in the soil and can be available to the crop. The definition of P_e by the USDA does not include surface runoff or percolation below the crop root zone. The effective precipitation can be estimated by:

$$P_e = P - RO - D_p$$

Where P_e is the effective precipitation stored in the soil root zone and available to plants.

The maximum effective precipitation cannot exceed the amount of water depleted from the root zone (soil water depletion) relative to the soil water content at field capacity. If the calculated effective precipitation is larger than depleted water, the soil water depletion should be used rather than the effective precipitation value. For a short time after a rain, the upward flow from the groundwater is very small and can be neglected while estimating effective precipitation.

In some regions of California where groundwater aquifers are deep and there is no shallow watertable, the capillary rise of water can be neglected. In such cases, the equation to calculate crop water needs can be simplified to define the net irrigation requirement as the difference between the crop evapotranspiration and effective rainfall:³¹

$$I_n = ET_c - P_e$$

Calculations of net irrigation water requirement require the real-time reference evapotranspiration provided by CIMIS or other ET sensors, and the estimation of effective precipitation to define the total amount of water depleted from the soil root zone since the last irrigation or rainfall event has occurred.

3.1.2 Crop ET Based Measurements

Measuring actual crop evapotranspiration is not easy and can be quite expensive, as it requires specific devices to accurately measure various physical microclimatic and crop parameters. The selection of a particular device or a service should be based on evaluating its advantages and disadvantages in term of cost, installation, ease of use, data access, and maintenance needs.

3.1.2.1 Estimate from the California Irrigation Management Information System (CIMIS)

Alternatively, crop evapotranspiration can be estimated considering weather-derived values of ET_0 and crop coefficients at user-selected time steps throughout the duration of the crop season. ET_0 can be obtained from CIMIS, whereas the crop coefficients are available from several published sources.

CIMIS was developed in 1982 and currently manages a network of over 145 weather stations throughout California. The network is operated by the California Department of Water Resources (DWR). It uses the Penman-Monteith equation modified by Pruitt and Doorenbos.³²

3.1.2.2 Actual Measurement With a Sensor Leveraging the Energy Balance Method

Actual crop evapotranspiration (ET_a) under field conditions can be obtained from the residual of energy balance method by measuring specific micro-climatic and crop-related parameters. The simplified surface energy balance can be written as shown:

$$R_n = G + H + LE$$

where R_n is the net radiation (Wm^{-2}), G is the soil heat flux (Wm^{-2}), H is the sensible heat flux (Wm^{-2}) and LE (Wm^{-2}) is the latent heat flux.

LE can be calculated from the residual between R_n , G and H as shown:

31 Brouwer, C. and Heibloem, M., 1986. *Irrigation water management: Irrigation water needs*. Food and Agriculture Organization of the United Nations, Training Manual No. 3, Rome.

32 Pruitt, W.O. and Doorenbos, J., 1977. *Empirical calibration, a requisite for evapotranspiration formulae based on daily or longer mean climatic data?* In: Proceedings of the International Round Table Conference on "Evapotranspiration", International Commission on Irrigation and Drainage, Budapest, Hungary, 20 pp.

$$LE = R_n - G - H$$

Latent heat flux density is then divided by the latent heat of evaporation (λ) to obtain the mass flux density of water vapor, which can be finally converted to hourly and daily ET:

$$ET_a = \frac{LE}{\lambda}$$

This approach requires accurate measurement of the main energy balance components. Analytical procedures have been developed to estimate the actual crop ET by means of lysimeters, the Eddy Covariance method, and the Surface Renewal method.^{33,34}

In addition, other methods are available to estimate some parameters of the surface energy balance using remote sensing techniques, such as SEBAL³⁵ and METRIC.³⁶

3.1.3 Soil Moisture Based Measurement

A soil moisture monitoring system can be used alone or in combination with other irrigation scheduling methods to improve irrigation management practices. Soil moisture monitoring makes it possible to keep track of what is happening in the soil root zone with regard to a) how much water infiltrates during an irrigation or rainfall; b) how much water is depleted (due to uptake by plants) between irrigations; and c) maintaining adequate soil water conditions. Overall, monitoring soil moisture status enables growers to match irrigation water applications with the actual crop water use (ET), with the aim of targeting optimal soil water conditions for plants growth and production. Irrigation scheduling based on soil moisture involves four steps:

1. Observe soil moisture frequently;
2. Start irrigation at specific levels of soil moisture (allowable depletion, allowable matric potential or tension);
3. Stop irrigation when soil moisture reaches target levels;
4. Predict the next irrigation based on the measured soil moisture depletion rate.

3.1.3.1 Irrigation Based on ET and Soil Moisture Monitoring

When used in combination with crop ET, monitoring soil water status allows irrigation to be triggered before water deficit conditions occur in the root zone (whereas crop ET alone can only provide information on the amount of irrigation water to apply). In addition, soil moisture monitoring can provide feedback information on soil water status to make sure irrigation events are managed adequately in terms of irrigation timing, frequency, and duration to prevent the occurrence of water deficit and excess. A soil moisture monitoring system consist

33 Shapland, T.M., McElrone, A.J., Snyder, R.L., and Paw U, K.T., 2012. *Structure function analysis of two-scale scalar ramps. Part I: theory and modeling*. Boundary-layer Meteorology, 145(1), 5-25.

34 Shapland, T.M., McElrone, A.J., Snyder, R.L., and Paw U, K.T., 2012. *Structure function analysis of two-scale scalar ramps. Part II: ramp characteristics and surface renewal flux estimation*. Boundary-layer Meteorology, 145 (1), 27-44.

35 Bastiaanssen, W., Noordman, E., Pelgrum, H., Davids, G., Thoreson, B., and Allen, R., 2005. *SEBAL Model with Remotely Sensed Data to Improve Water-Resources Management under Actual Field Conditions*. J. Irrig. Drain Eng., 131(1), 85-93.

36 Allen, R., Tasumi, M., and Trezza, R., 2007. *Satellite-Based Energy Balance for Mapping Evapotranspiration with Internalized Calibration (METRIC)—Model*. J. Irrig. Drain Eng., 133(4), 380-394.

of sensors that reveal the current soil water status in the root zone during and between irrigation events. It can provide answers to several questions:

- When should irrigation take place?
- What is the water uptake pattern of the roots?
- Did enough water infiltrate the soil?
- Is too much water being applied?
- What was the depth reached by the irrigation water?

Soil moisture can be measured in terms of soil water content and tension. Soil moisture content tells how much water is available per unit of soil and is expressed in percent (% of weight or % of volume) or inches of water per foot of soil. The soil moisture tension indicates how strongly water is held by soil particles, meaning that the higher the tension, the drier the soil and the more difficult it is for plants to extract water. The two types of measurement can be related through the development of soil-specific water retention curves (Figure 27).

Figure 27: Soil Water Retention Curves for Different Soil Textures

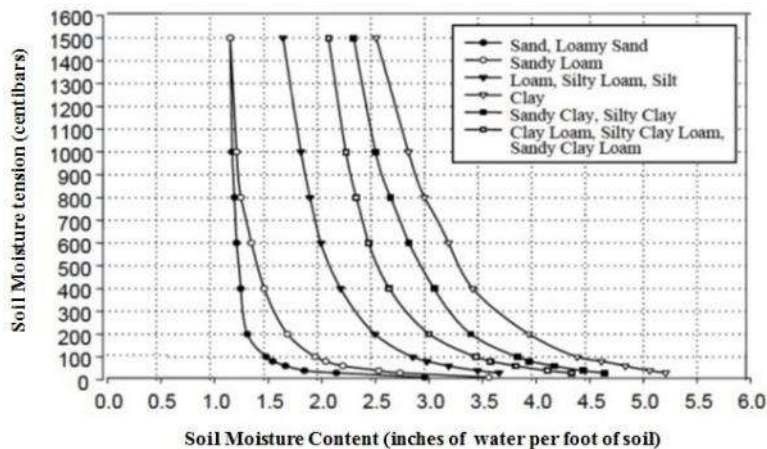

Source: Ley *et al.* (1996)

3.1.3.2 Types of Soil Moisture Sensors

Some sensors measure soil water content while others measure soil water tension. In reality all sensors measure soil properties or parameters that are related to soil moisture content or tension through a specific calibration. As such, soil moisture sensors are categorized into two major groups differing for the measured parameters:

- Sensors measuring soil water content: Neutron probes, Time Domain Transmissivity (TDT), Capacitance, Time and Frequency Domain Reflectometry sensor (TDR, FDR) and Amplitude Domain Reflectometry (ADR);
- Sensors measuring soil moisture tension: Tensiometers and Granular Matrix sensors.

The selection of a device should be based on evaluating its advantages and disadvantages in terms of cost, installation, ease of use, data access, and maintenance needs. Examples of sensors measuring tension: Irrrometer and Hortau. Examples of sensors measuring water

content: WiseConn with Sentek probes and CPS with Aquacheck probes. Some vendors provide the sensors as leased assets, so growers do not have to maintain them (*e.g.*, Hortau). In common irrigation practice, the recommended values of soil moisture tension and content at which irrigation should occur are based on 50% of available water capacity (AWC) and are shown for different soil textures (Table 7) and tension (Table 8) .

Table 7: Recommended Values of Soil Moisture Content at Which Irrigation Should Occur for the Different Soil Textures

Soil Type	Available Water (in/ft)	Allowable Depletion (in/ft)	Available Water in 4-ft Root Zone (in)	Allowable Depletion in 4-ft Root Zone (in)
Coarse Sand	0.5	0.25	2.0	1.0
Loamy Sand	1.0	0.50	4.0	2.0
Sand Loam	1.5	0.75	6.0	3.0
Fine Sandy Loam	2.0	1.00	8.0	4.0
Clay Loam	2.2	1.10	8.8	4.4
Clay	2.3	1.15	9.2	4.6
Organic Clay Loams	4.0	2.00	16.0	8.0

Source: Hanson *et al.*, 2007a.

Table 8: Recommended Values of Soil Moisture Tension at Which Irrigation Should Occur for the Different Soil Textures

Soil Type	Soil Moisture Tension (centibars)
Sand or Loamy Sand	40-50
Sandy Loam	50-70
Loam	60-90
Clay Loam or Clay	90-120

Source: Hanson *et al.*, 2007a.

Additional information on soil moisture measurements can be obtained from the UC-ANR publication “Monitoring soil moisture for irrigation water management”, available at <http://anrcatalog.ucanr.edu/Details.aspx?itemNo=21635>.

3.1.4 Plant Water Based Measurements

Plant based measurements can be used to verify proper irrigation scheduling. It is the closest to traditional irrigation practices because it requires onsite inspection rather than remote sensing. Water status in plant tissues directly affects metabolic and physiologic processes. Plant water status provides information about how water moves through the soil-plant system and about atmospheric evaporative demand.

Numerous methods have been developed to measure or monitor parameters directly or indirectly related to plant water status. Some of these are listed:

- Plant water potential
- Relative water content
- Hydraulic press
- Organ dimensions
- Stomatal opening
- Canopy temperature
- Xylem cavitation
- Expansive growth of leaves or stems

The choice of a specific measurement method depends on the plant's relative sensitivity to water deficit and the particular purpose of the measurement (Hsiao, 1973).³⁷ The most common parameters measured in the field are plant water potential and canopy temperature.

The plant water potential (ψ) is critical for water transport between soil, plant and atmosphere. Thermocouple psychrometry, hydrometry, Shardokow dye method, or a pressure chamber³⁸ are used to measure plant water potential. However, pressure chamber is the most common and robust method used on the field. Midday stem water potential (SWP) was proposed as accurate and reliable approach to determinate water stress in prunes (McCutchan *et al.*, 1992).³⁹

Shackel *et al.* (1997 and 2000)^{40,41} developed plant water potential models for different crops, such as almond, walnut and grapes. Reference values of plant water potential, which depends on soil and weather conditions, can be defined for these crops in different areas of California. Additional information on irrigation scheduling using stem water potential can be found at: http://informatics.plantsciences.ucdavis.edu/Brooke_Jacobs/index.php.

Canopy temperature is another method used to assess the plant water status indirectly. Water deficit is shown when canopy temperature significantly increases above air temperature as a result of stomata closure. Stress degree day (SDD) is an indicator that represents the summation of canopy-air temperature difference over time.⁴² SDD is also used to schedule irrigation.

37 Hsiao, T. C. 1973. *Plant responses to water stress*. Annual Review of Plant Physiology 24, 519-570.

38 Scholander, P.F., Hammel, H.T., Hemmingsen E.A. and Bradstreet, E.D., 1964. *Hydrostatic pressure and osmotic potential in leaves of mangroves and some other plants*. Proc. Natl. Acad. Sci. U.S.A. 52:119-125.

39 McCutchan, H. and Shackel, K.A., 1992. *Stem water potential as a sensitive indicator of water stress in prune trees (Prunus domestica L. cv. French)*. Journal of the American Society for Horticultural Research, 117, 606-611.

40 Shackel, K.A., H. Ahmadi, W. Biasi, R. Buchner, D. Goldhamer, S. Gurusinghe, J. Hasey, D. Kester, B. Krueger, B. Lampinen, G. McGourty, W. Micke, E. Mitcham, B. Olson, K. Pelletrau, H. Philips, D. Ramos, L. Schwankl, S. Sibbett, R. Snyder, S. Southwick, M. Stevenson, M. Thorpe, S. Weinbaum, and J. Yeager, 1997. *Plant water status as an index of irrigation need in deciduous fruit trees*. HortTechnology 7:23-29.

41 Shackel, K., B. Lampinen, S. Sibbett and W. Olson., 2000. *The relation of midday stem water potential to the growth and physiology of fruit trees under water limited conditions*. Acta Hort. 537:425-430.

42 Jackson, R.D., Reginato, R.J. and Idso, S.B., 1977. Wheat canopy temperature: A practical tool for evaluating water requirements. Water Resour. Res. 13: 651-656.

Measurements of plant water status can be used to provide a “safety net” when ET-based or soil-moisture-based irrigation scheduling is implemented. Plant water-based monitoring helps to determine when irrigation is needed (“too much stress”). However, it does not say how much is required and its accuracy can vary depending on who makes the measurement (such as pressure chambers). In addition, plant measurement techniques are different for each crop.

3.2 Deficit Irrigation (DI) Based on Advanced Phenology Models

Regulated deficit irrigation or RDI has been successfully used in different crops such as maize,^{43,44} fruit trees,^{45,46} and grapevines.⁴⁷ In these studies, crop yield was maintained and production quality was improved in some cases, while the amount of applied water was substantially reduced. Detailed information about partial ET irrigation is available Appendix D authored by UCD and UC-ANR. The project team covers the essentials in this section.

3.2.1 Nut Crops

In nut crops, deficit irrigation strategy must be considered in its effects on the crop yield in the current and following seasons. A poorly implemented partial irrigation strategy may generate a great risk of reducing crop production for a few years following that when water deficit occurs.

The effects of water restrictions on crop yield depend on the severity of water stress and the specific sensitivity of the growth stage to deficit. Nut crops have three main growth stages:

- Early season: this stage is sensitive to water stress. During this period the following phenologic processes occur: vegetative growth, bud break, bloom, flowering and fruit set, establishment of fruit positions and development of carbohydrate reserves for future yields. Water deficit lead to reduced canopy growth, reduction of fruiting spurs and future yield, which could be cumulative in the following years if water deficit persists. In consideration of these processes and crop physiological responses, partial irrigation should be avoided during this period.
- Fruit Growth and Development: again, this a sensitive period to water stress in most nut crops, and could be broken down in a three-stage process. The first stage corresponds to fruit growing in size, the second to embryo enlarging, and the third stage is

43 Kang, S., Shi, W. and Zhang, J., 2000. An improved water-use efficiency for maize grown under regulated deficit irrigation. *Field Crops Research*, 67(3), 207-214.

44 Farré, I. and Faci, J.M., 2006. *Comparative response of maize (Zea mays L.) and sorghum (Sorghum bicolor L. Moench) to deficit irrigation in a Mediterranean environment*. *Agricultural Water Management*, 83(1), 135-143.

45 Girona, J., Mata, M., Goldhamer, D.A., Johnson, R.S. and DeJong, T.M., 1993. *Patterns of soil and tree water status and leaf functioning during regulated deficit irrigation scheduling in peach*. *Journal of the American Society for Horticultural Science*, 118(5), 580-586.

46 Goodwin, I. and Boland, A.M., 2002. *Scheduling deficit irrigation of fruit trees for optimizing water use efficiency*. In: *Deficit Irrigation Practices*. Water Reports No. 22. FAO. Rome, Italy, pp. 67-79.

47 McCarthy, M.G., Loveys, B.R., Dry, P.R. and Stoll, M., 2002. *Regulated deficit irrigation and partial rootzone drying as irrigation management techniques for grapevines*. In: *Deficit Irrigation Practices*. Water Reports No. 22. FAO. Rome, Italy, pp. 79-87.

characterized by increase in seeds' weight. Water deficit should be avoided during the first and third stages, whereas mild water stress could occur during the second stage with significant impacts on some nut crops.

- Postharvest: this is in general the more tolerant stage to water stress in most nuts crops, with the exception of almond. However, irrigation cannot be significantly reduced, as fruiting buds usually develop during this period.

The deficit irrigation strategy should be implemented considering the specific characteristics of each nut crop. Some considerations for implementing partial irrigation strategies in almond and pistachio are presented in the following sections.

3.2.1.1 Almond

Almond is a crop moderately tolerant to water stress.^{48,49} The impact on crop yield will be based on the magnitude of water stress and the specific growth stage when stress occurs. Significant water deficits in almond trees normally show their effects during the crop season when stress occurs, and also during a few following seasons even if when full irrigation is then applied.

Different stress management strategies can be implemented depending on the severity of water supply limitations, as suggested by the University of California drought management website (http://ucmanagedrought.ucdavis.edu/Agriculture/Crop_Irrigation_Strategies/Almonds/):

- Strategy 1: Moderate water stress
- Strategy 2: More severe water stress
- Strategy 3: “Staying Alive” Drought

Strategies 2 and 3 are options rarely used and should be avoided when possible. Severe water stress can adversely affect yield as a result of reduction of vegetative growth, and decrease of kernel size and fruit load. Following a deficit irrigation period, the normal yield is reached again after several years of full irrigation.⁵⁰ However, the best yield results are obtained when moderate water stress (Strategy 1) is applied.

The fruit and kernel development can be divided into three different stages (Figure 28):

- Stage 1. Seed and hull reach full size. Hull shell and integuments grow rapidly.
- Stage 2. Embryo (edible kernel) reaches full size. The fruit is subject to rapid expansion.
- Stage 3. Embryo loses moisture. When hull, shell and kernel differentiation are complete, kernel begins to accumulate solids at a continuous rate until harvest.

48 Fereres E. and Goldhamer D.A., 1990. Deciduous fruit and nut trees. In: Stewart BA, Nielsen DR (eds). Irrigation of agricultural crops Mon.#30. American Society of Agronomy, Madison WI, pp. 987-1017.

49 Torrecillas A., Alarcon J.J., Domingo R., Planes J., and Sanchez-Blanco M.J., 1996. Strategies for drought resistance in leaves of two almond cultivars. *Plant Science* 118:135-143.

50 Prichard, T., Asai, W., Verdegaal, P., Micke, W. and Teviotdale, B., 1994. *Effects of water supply and irrigation strategies on almonds. Modesto: Almond Board of California*. Comprehensive Project Report 1993-94.

Figure 28: Almond Fruit Development Stages

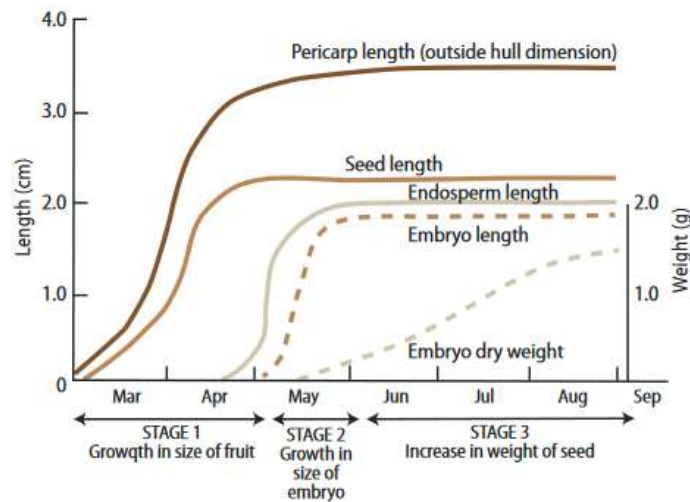

Source: Micke (1996)⁵¹

Water stress should be avoided during periods of active vegetative growth and during fruit development. Moderate water stress during the vegetative growth can reduce canopy growth and the future crop yield. This effect may not be as extensive in the year following water deficit but a prolonged water stress can have a cumulative effect in the consecutive years.⁵²

During the fruit growth periods (Stage 1 and Stage 2), water deficit should be avoided, as it could increase nut drop and also result in smaller kernels. However, the right water stress during Stage 3 is challenging to define. Mild-to-moderate stress during the hull split period (Stage 3) can have positive effects such as control of excessive vegetative growth, reduction of hull rot and improvement of the hull split. In contrast, excessive water application in this period can extend the duration of hull split period and thus delay harvest. In addition, severe stress post-hull split/pre-harvest could affect kernel quality as reported by Goldhamer and Viveros (2000)⁵³ and thus should be avoided. Some studies demonstrated that moderate water stress after the onset of hull split had little or no impact on individual kernel dry weight.^{54,55,56} The post-harvest period is more sensitive to water stress than pre-harvest period. During this

51 Micke, W. C., 1996. Almond production manual. Division of Agriculture and Natural Resources, University of California, Oakland, CA. 289 p.

52 Lampinen, B., Dejong, T., Weinbaum, S., Metcalf, S., Negron, C., Viveros, M., Mc Ilvane, J., Ravid, N. and Baker, B., 2007. *Spur dynamics and almond productivity*. Modesto: 2007-2008 Annual Management Website: ucmanagedrought.ucdavis.edu.

53 Goldhamer, D.A. and M. Viveros, 2000. *Effects of preharvest irrigation cutoff durations and postharvest water deprivation on almond tree performance*. Irrig. Sci. 19:125-131.

54 Teviotdale, B.L., D.A. Goldhamer and M. Viveros, 2001. *Effects of deficit irrigation on hull rot disease of almond trees caused by *Monilinia fructicola* and *Rhizopus stolonifer**. Plant Dis. 85(4):399-403.

55 Shackel, K., R. Buchner, J. Connell, J. Edstrom, A. Fulton, B. Holtz, B. Lampinen, W. Reil and M. Viveros, 2004. *Final Report: Deficit Irrigation Management During Hull Split*. Modesto: Final Report to The Almond Board of California.

56 Goldhamer, D.A., Viveros, M. and Salinas, M., 2006. *Regulated deficit irrigation in almonds: Effects of variations in applied water and stress timing on yield and yield components*. Irrigation Science 24(2):101-114.

stage, fruit buds are developed and vulnerable to water stress with negative impacts on crop yield.⁵⁷

Doll and Shackel (2015)⁵⁸ suggest two methods for managing deficit irrigation in almonds:

- Method 1: DI at hull split. In this case, deficit irrigation is applied only after kernel fill and until 90% hull split is achieved, and full irrigation is applied during all other stages. The most accurate method for scheduling irrigations is by assessing the tree water status by measuring mid-day stem water potential (SWP) with a pressure chamber along the crop season. Irrigation water is then applied when SWP reaches specific threshold values. Shackel et al. (2004)⁵⁹ recommended applying water when trees reach SWP values of -14 to -18 bars. This strategy has the important benefit of reducing hull rot and improving the harvesting conditions, in terms of force and time required for shaking.
- Method 2: Proportional DI. Water is applied as a fixed fraction of ET_c using the ET-based irrigation scheduling method (see Section 3.1). As such, a water depth corresponding to a fraction of ET_c is applied at each irrigation event during the season

Goldhamer et al., (2006)⁶⁰ studied different irrigation schedules during pre-harvest and post-harvest periods, and uniform deficit rates across the season over four years with moderate water stress (between 55 and 85 percent of ET_c). Results showed that the best strategy in terms of yield and yield components is obtained when a uniform deficit rate is applied throughout the season, relative to potential crop evapotranspiration. Yield is slightly reduced but this strategy minimizes the risk of larger yield reductions that may occur as a consequence of irrigation deficits during the most sensitive stages. In general, a moderate water stress strategy is recommended during the season, with water applications conducted at 85% of the ET_c (Table 9).

Another approach entails scheduling irrigations based on plant water status, specifically irrigating when the midday stem water potential measured by pressure chamber reaches pre-determined thresholds values indicating the occurrence of plant water stress. In both strategies, schedules must also account for the average application efficiency of the irrigation system (such as drip).

57 Goldhamer, D.A. and Holtz, B., 2009. *Rational Early Season Drought Planning for Almond Growers. The Pomology Post*. Madera County. Vol 59, March, 2009.

58 Doll, D. and Shackel, K., 2015. Drought Management for California Almonds. *Impacts of Stress on Almond Growth and Yield*. Pub. 8515. UCANR Publications.

59 Shackel et al., 2004. *op. cit.*

60 Goldhamer et al., 2006. *op. cit.*

Table 9: Example of Deficit Irrigation Levels (DIL) for Almonds

Periods	DIL (%) for Proportional DI	DIL (%) for Hull Split DI
Mar 1-15	85	100
Mar 16-31	85	100
Apr 1-15	85	100
Apr 16-30	85	100
May 1-15	85	100
May 16-31	85	100
Jun 1-15	85	50
Jun 16-30	85	50
Jul 1-15	85	50
Jul 16-31	85	50
Aug 1-15	85	100
Aug 16-31	85	100
Sep 1-15	85	100
Sep 16-30	85	50
Oct 1-15	85	0
Oct 16-31	85	0
Nov 1-15	85	0

Using Proportional Deficit Irrigation (DI), and Hull Split Deficit Irrigation, expressed as percentage of potential crop ET (ET_c).

Source: Goldhamer *et al.* (2006)

In practice, almond growers must deal with other factors that should be considered in reducing water.⁶¹ In the context of the present project, the grower at site #2 selected Hull Split DI to control disease outbreak and simplify field activities before harvest. He did not apply the full amount if deficit because the orchard consists of several varieties maturing at different time. Three or four varieties of almond trees within one field are not uncommon, and the trees are set in a particular pattern to optimize pollination. While reducing irrigation at a particular time might not stress a tree of one variety, it could have adverse effects on another variety. This limitation can be minimized by applying water deficit evenly across the season with the Proportional DI strategy, but it does not provide the added benefits in disease control.

⁶¹ Doll and Shackel, 2015. *op. cit.*

3.2.1.2 Pistachio

Pistachio is an extremely drought-tolerant species.^{62,63} DI strategies can be followed during drought periods to save water, and in normal years to optimize water usage and reduce production costs. However, drought tolerance does not necessarily mean that pistachio trees can produce well with little water. The impacts of deficit irrigation depend on the crop growth stage when water limitations occur.

Goldhamer et al.^{64,65} conducted research studies on deficit irrigation of pistachio in California. Results showed that deficit irrigation cannot be applied for the entire crop season and reduced water applications should be conducted only during stress-tolerant periods. Three pistachio growth stages were identified and classified based on tolerance to water stress:

- Stage 1: boom, leaf out and shell expansion
- Stage 2: shell hardening
- Stage 3: nut filling, shell split and hull split

Water shortages should not occur during Stages 1 and 3. However, partial irrigation can be implemented during Stage 2 and during post-harvest periods, which will minimize negative impacts on fruit yield or quality. Partial irrigation scheduling in these stages can be implemented by applying a fixed fraction of ET_c using the ET-based irrigation scheduling method (Section 3.1).

Various levels of water stress on stress-tolerant periods were evaluated. Results showed that during Stage 1, water stress slightly increases shell splitting but reduces the nut size at harvest. However, Phene et al. (1987)⁶⁶ found that water applications at 50% of ET_c during Stage 2 had no effect on yield. Also, deficit irrigation during Stage 2 reduces fungal disease. The percentage of reduction depends on the soil type. Shallow soils retain less water and have a smaller moisture zone, so irrigation at 50% of ET_c could be considered. In soils with deeper root zones and greater water-holding capacity irrigation could be reduced at 25% of ET_c during Stage 2, without causing significant yield impacts on yield. In orchards characterized by heterogeneous soils deficit irrigation strategies should be very carefully evaluated prior to implementation.

62 Spiegel-Roy, P., Mazigh, D. and Evenari, M., 1977. *Response of pistachio to low soil moisture conditions*. Journal American Society of Horticultural Science, 102, pp. 470-473.

63 Goldhamer, D.A., Beede, R., Moore, J.M., Weinberger, G. and Menezes, J., Jr., 1983. *Water use requirements and physiological response to water stress in pistachio*. Annual report of the California Pistachio Commission, Crop Year 1982 - 1983, pgs. 53-57.

64 Goldhamer, D.A., Kjelgren, R., Beede, R., Williams, L., Moore, M.J., Lane, J., Weinberger, G. and J. Menezes, 1985. *Water use requirements of pistachio trees and response to water stress*. Annual report of the California Pistachio Commission, Crop Year 1984 - 1985, pgs. 85-92.

65 Goldhamer, D.A. and B. H. Beede, 2004. *Regulated deficit irrigation effects on yield, nut quality and water-use efficiency of mature pistachio trees*. Journal of Horticultural Science & Biotechnology 79 (4) 538-545.

66 Phene, B.C., Goldhamer, D.A., Menezes, J., Beede, R., Weinberger, G. and Cervantes, Z., 1987. *Response of Pistachio Trees to Three Consecutive Years of Irrigation Cut-off*. In Annual Report, Crop Year 1986-1987.

A sound deficit irrigation strategy can reduce water usage with only mild impacts on crop yield during the current and following crop seasons. Goldhamer (2005)⁶⁷ recommended a deficit irrigation strategy in which the pistachio trees should be fully irrigated at ET_c during Stage 1 and Stage 3, whereas water should be applied at 50% of ET_c during Stage 2 (from mid-May to early July). During the post-harvest period, irrigation can be applied at 25% of ET_c (Table 10).

Table 10: Deficit Irrigation Level (DIL) for Pistachio Trees

Period	Growth Stage	DIL (%)
Apr 1-15	Stage 1	100
Apr 16-30		100
May 1-15		100
May 16-31	Stage 2	50
Jun 1-15		50
Jun 16-30		50
Jul 1-15	Stage 3	100
Jul 16-31		100
Aug 1-15		100
Aug 16-31		100
Sep 1-15		100
Sep 16-30	Stage 4	25
Oct 1-15		25
Oct 16-31		25
Nov 1-15		25

Expressed as percentages of potential crop ET (ET_c).

Source: Goldhamer (2005)

The crop coefficients for pistachio are not as well known as for almond. Pistachio trees are also more tolerant to higher levels of salinity in the soil. Recently, Zaccaria and Sanden published preliminary results⁶⁸ based on multi-year trials funded the by CDFA and the California Pistachio Research Board. The actual amount of ET (ET_a) is measured by the residual of energy balance method through a combination of surface renewal and eddy covariance equipment in three mature well-watered pistachio orchards in the San Joaquin Valley with different levels of salinity. The ET_a values were compared to reference ET values (ET_o) values from CIMIS network. The comparison showed that ET_a is affected by the level of salinity and that the crop coefficient

67 Goldhamer, D.A., 2005. "Irrigation Management" in University of California Pistachio Production Manual. Edited by L. Ferguson. pgs. 103-116.

68 Zaccaria, D. et al. *Determination of soil-plant-water dynamics of mature pistachio orchards grown under saline conditions*. Preliminary results file to the California Pistachio Research Board, 2017.

can be estimated by the smaller canopy cover due to smaller trees. Curves were not available yet during this project, and the project team decided to deploy stations at site #1 to track ET_a.

3.2.2 Tomato

In California, processing tomato fields are mainly irrigated using subsurface drip irrigation (SDI) (63%), although furrow irrigation (33%) remains in some areas.⁶⁹ ET-based irrigation scheduling is one of the methods commonly used to estimate the amount of water to apply with SDI systems. Under normal conditions, full irrigation is conducted throughout the entire crop season to maximize crop production. Research shows that tomatoes under SDI should be irrigated with small and frequent water applications.

DI strategy can be implemented without incurring in significant yield losses when tomato fields are irrigated with SDI systems. Tomatoes are sensitive to water stress during fruit set, when moderate and severe levels of water deficit can significantly reduce the yield. After fruit set, however, a reduction in irrigation can be implemented with minimal impact on crop yield. Two alternative deficit irrigation strategies are usually recommended:

- Strategy 1: full irrigation during the first part of the crop season followed by little or no irrigation for the remaining part of the season.
- Strategy 2: implementing deficit irrigation during the entire crop season by applying a specific fraction of the water required to achieve the maximum yield.

There is some uncertainty in predicting which deficit irrigation strategy may result in the greatest yield reduction. Strategy 2 probably reduces the yield more than Strategy 1 under similar field conditions. Also, reductions in irrigation rates during certain specific stages of the crop season (Strategy 1) can have a significant effect on fruit quality in terms of total solids and soluble solids.^{70,71,72,73} However, both strategies may result in some water savings per unit of cropped area and increases in water use efficiency. The project team selected Strategy 1 at the demonstration field at UCD (site #3) and provided the option to the growers (site #4).

The water stress levels to be adopted depend on different aspects but mainly on soil water holding capacity. Different research trials were conducted in controlled research plots with interesting results that are summarized in the drought management website of UCD:

69 Tindula, G.N., Orang, M.N. and Snyder R.L., 2013. *Survey of Irrigation Methods in California in 2010*. J. Irrig. Drain Eng. 139 : 233-238.

70 Johnstone, P.R., Hartz, T.K., LeStrange, M., Nunez, J.J. and Miyao, E.M., 2005. *Managing fruit soluble solids with late-season deficit irrigation in drip-irrigated processing tomato production*. HortScience, 40(6), 1857-1861.

71 Patanè, C. and Cosentino, S.L., 2010. *Effects of soil water deficit on yield and quality of processing tomato under a Mediterranean climate*. Agricultural Water Management, 97, pp. 131-138.

72 Patanè, C., Tringali, S. and Sortino, O., 2011. *Effects of deficit irrigation on biomass, yield, water productivity and fruit quality of processing tomato under semi-arid Mediterranean climate conditions*. Scientia Horticulturae, 129(4), 590-596.

73 Favati, F., Lovelli, S., Galgano, F., Miccolis, V., Di Tommaso, T., and Candido, V., 2009. *Processing tomato quality as affected by irrigation scheduling*. Sci. Hortic., 122 , pp. 562-57.

http://ucmanagedrought.ucdavis.edu/Agriculture/Crop_Irrigation_Strategies/Processing_Tomatoes/.

Different fractions of tomato ET_c were applied during the 60 days before harvest in processing tomatoes grown on two different soil types. The results showed that at 50% of ET_c , the yields were slightly higher than 90% of the yield from fully irrigated tomatoes grown on clay-loam soil. However, yield reductions may be greater in a sandy loam soil when less than 75% of ET_c is applied. The recommended conservative deficit irrigation strategy is illustrated in Table 11. Specifically, during early season irrigation events aim at fully matching the crop water requirements so that no water stress will occur during the vegetative growth stage. Irrigation cutback may start about six weeks before harvest, with water applications at 75% of ET_c .

Table 11: Proposed Deficit Irrigation Levels (DIL) for Processing Tomatoes

Period	DIL (%)
May 1-15	100
May 16-31	100
Jun 1-15	100
Jun 16-30	100
Jul 1-15	100
Jul 16-31	75
Aug 1-15	75
Aug 16-31	75

Expressed as percentages of potential crop ET (ET_c) that correspond to fully watered tomato plants.

Source: UC Agricultural and Natural Resources

ET_c is commonly estimated by multiplying the reference evapotranspiration (ET_0) by the appropriate crop coefficient (K_c). ET_0 is estimated using meteorological data and the K_c varies with the crop growth stage. Results from recent research studies⁷⁴ showed that K_c can be estimated based on the canopy size (fractional canopy cover; Figure 29).

⁷⁴ Hanson, B., and May, D.M., 2006. *New crop coefficients developed for high-yield processing tomatoes*. California Agriculture, 60(2):95-99.

Figure 29: Relation Between Average Crop Coefficient and Canopy Coverage

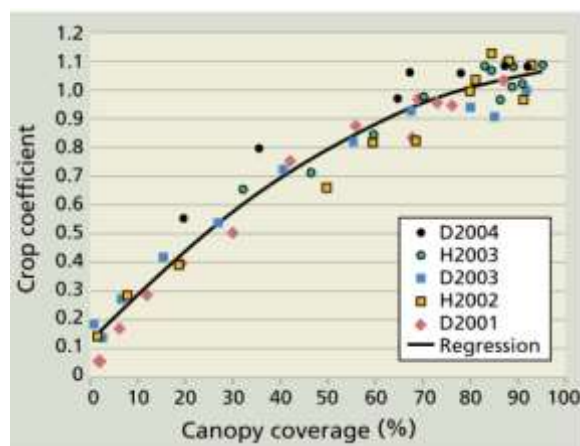

Source: Hanson and May (2006)

3.2.3 Alfalfa

Alfalfa is relatively drought tolerant and offers some degree of adaptability to water stress. DI strategies can be adopted, but the impact should be carefully evaluated. Impacts of water stress on alfalfa depend on several aspects like soil characteristic (texture, depth, salinity), weather conditions, timing and duration of water deficits, and on the crop variety. However, any DI strategy will adversely impact the alfalfa yield relative to that resulting from full irrigation. There are two main DI strategies that can followed at the selected alfalfa fields:

- Strategy 1: Starvation Diet. DI is applied during each growth period. Two different options can be implemented: reduce the number of irrigations between cuttings (flood and sprinkler irrigation) or reduce the amount of water applied per irrigation (sprinkler or drip irrigation).
- Strategy 2: Partial-Season irrigation. During the early-season cuttings, fully irrigate the crop and then apply deficit irrigation towards the summer when the ET demand is high.

Strategy 1 reduces the yield at each crop cycle throughout the season. However, when Strategy 2 is applied, important benefits are achieved in term of alfalfa yield and quality. The highest yields are usually obtained from the first cuttings in the spring and early summer.⁷⁵ Production is reduced during the last crop cycles that can produce about 25% of the total annual production. The deep root system of alfalfa allows access to deep soil moisture and water uptake from deep soil layers, especially during the necessary dry-down periods (irrigation cutoffs) before and after the cuttings. There are regional differences in what irrigation strategy works best for alfalfa. In the intermountain areas, a large portion of the total annual production of alfalfa (around 75%) is obtained by mid-July.⁷⁶ Thus in these areas, the best partial irrigation

⁷⁵ Orloff, S., Bali, K. and Putnam, D., 2014. *Deficit irrigation of alfalfa and grasses: What are the impacts/options?* Proceedings, 2014 California Alfalfa, Forage, and Grain Symposium, Long Beach, CA, 10-12 December, 2014. UC Cooperative Extension, University of California, Davis, CA.

⁷⁶ *Ibid.*

strategy could be to irrigate until the second cutting and then stop irrigations during the rest of the crop season. In contrast, studies in the Sacramento Valley showed that early summer cut-off (July) of irrigation followed by fall irrigation could save water and minimize alfalfa yield losses.⁷⁷ In addition, alfalfa quality is higher in spring, which contributes to a higher market price for hay during this period. It is therefore not advisable to reduce water applications in spring since it may significantly impact yield, quality, and net profit during this specific time. In summary, Strategy 2 is recommended for minimizing reductions of farmers' profit.

The project team had an in-depth discussion with the grower at site #5 to compare the benefit of SDI against flood irrigation for alfalfa. Some water can be saved using more precise irrigation (sub-drip) but the water must be pressurized with a booster pump. If the water comes from the canal (surface water) most of the years, the most energy efficient approach is to flood the field with siphons rather than using a pump. As a result, the project team focused on optimizing flood irrigation.

3.3 Common Method to Use Optimized Irrigation Schedule

The staff of PWE interviewed dozens of growers during this project. They also consulted with four farm advisors and extension specialists from UC-ANR to understand the best farming practices in alfalfa (Dr. Khaled Bali), almond (Alan Fulton), pistachio (Blake Sanden), and tomato (Tim Hartz). UC-ANR developed a website with useful resources for drought management.⁷⁸

While irrigation strategies will vary for different crops and different individual fields, the project team identified four common steps that should be implemented in an irrigation optimization program. The steps require data computation and can be automated by the decision-support tools created by PWE during the project: pump monitor and irrigation advisor.

The simpler and more fundamental steps should be emphasized initially:

1. Know the water application rate by checking the irrigation system and the pumping plant infrastructure;
2. Start with a simple irrigation schedule based on ET and the soil type.

After this baseline has been established, it is possible to make adjustments and incorporate more information to be more efficient, but it requires more advanced tools and data analysis:

3. Validate the irrigation schedule with on-farm sensors and aerial images;
4. Optional: apply deficit irrigation during drought years.

The unknown factor is the depth of the root-zone. It varies greatly across plants. In general, the team found that annual crops tend to be over-irrigated because they have a shallower root.

Discussions with the Almond Board of California (ABC), and other crop associations confirmed the challenge to strike a balance between helping farms integrating new tools and making sure

⁷⁷ Hanson, B., Putnam, D., and Snyder, R., 2007. *Deficit irrigation of alfalfa as a strategy for providing water for water-short areas*. Agricultural Water Management 93, 73-80.

⁷⁸ University of California Division of Agricultural and Natural Resources. *Drought management tip sheets*. ciwr.ucanr.edu/california_drought_expertise/droughttips. Accessed 12 Feb. 2018.

that the community of progressive and conservative growers focuses on the fundamentals. For instance, the ABC conference in 2016 hosted two classes, “Irrigation 1.0” and “Irrigation 2.0”, along a similar separation. The key is to provide an end-to-end solution to growers (from pump to nozzle) with two degrees of difficulty, rather than promoting the divide between people working with pump infrastructure (*e.g.*, electricians) and people irrigating the field (*e.g.*, agronomists).

3.3.1 Check Irrigation System and Pumping Plant Infrastructure

The existing irrigation system should first be checked for leaks. The pump should be checked to validate the pump capacity against its design value. The application rate converted in gallons per minute (GPM) should match the available water flow at the flow. This can be done with manual pump tests and distribution uniformity (DU) tests, and also with PWE’s PumpMonitor™ product. If there is mismatch between demand (field) and supply (pump), it should be investigated and resolved before a precise irrigation schedule can be implemented.

An example of comparison is shown for an almond field near the experimental farm at CSU Fresno in Figure 30. The pump capacity matches the design application rate in gallons per minute (GPM). However, there is a mismatch for one of the irrigation sets. A visual check of the pressure gauge after the filter confirmed that there was not enough pressure for the water to be applied evenly on that block. There were a few leaks and clogged lines. Addressing them is not only good for the trees but it can also result in energy savings because the pump is likely not working at its optimum design point (low OPE).

Figure 30: Comparing Application Rate (Field) and Flow Capacity (Pump) in Gallons per Minute

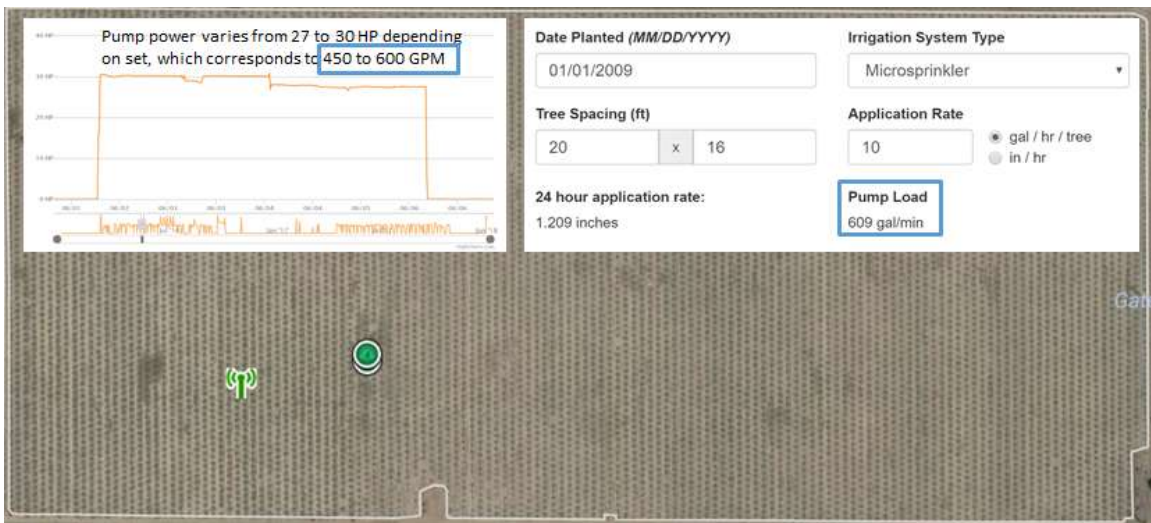

The load from the field and the supply by the pump can be compared in gallons per minute (GPM). On the right, the application rate of the nozzle and the tree spacing requires 609 GPM. On the left, a typical pump cycle shows a power level of 30 HP that corresponds to 600 GPM per pump test. However, the power level and the water flow come down for one the irrigation sets. There is a problem on that block, and most trees will not receive the intended water application in inches to compensate for ET.

Source: PowWow Energy

Soil mapping and DU testing take time and are a significant cost because it scales per acre. DU tests are done typically in increments of 40 acres. This is why farms have also relied on aerial imagery to identify “weak” spots to focus on Figure 31 shows an example of two fields near the Hansen Agricultural Research and Education Center in Ventura. The field on the left has uniform trees, in part to good maintenance of the irrigation system. The DU is likely very high. On the contrary, the field on the right has large variation in size and canopy cover. This is an extreme case, and the DU is likely very low. Existing research indicates that the majority of the vegetation uniformity is correlated to the DU.

Figure 31: Example of Good (Left) and Poor (Right) Distribution Uniformity (DU)



Source: UC-CE in Ventura

Pump testing also has limitations because a test is only a snapshot taken at one time during the season. As illustrated in Figure 32, pump records from smart meters can point to sub-optimal performance of the pumping system if properly calibrated and analyzed as PWE’s Pump Monitor product does. In this example, the problem comes from the well. The water table is falling during the season. In the best scenario, the pump capacity varies. In the worst scenario, the pump starts to cavitate and the farm can lose its source of water during the summer.

Figure 32: Drop in Power Level During the Season as the Water Table is Falling



Water flow is not constant and pump OPE goes down as well, resulting in additional energy consumption.

Source: PowWow Energy

In summary, checking the field from pump to nozzle is a critical step, not only at time of design but also before every growing season to assess the performance of the irrigation infrastructure.

3.3.2 Start with Irrigation Schedule Based on Crop ET and Soil Type

CIMIS data for reference evapotranspiration (ET_0) provide a good starting point. PWE integrated a basic irrigation scheduler from the crop estimations from ET_0 and published crop coefficient values (K_c). An irrigation schedule can be developed based on irrigation water requirements determined from ET_c and soil type (section 3.1) as shown in Figure 33.

Figure 33: ET Schedule for a Mature Almond Orchard Near Tulare

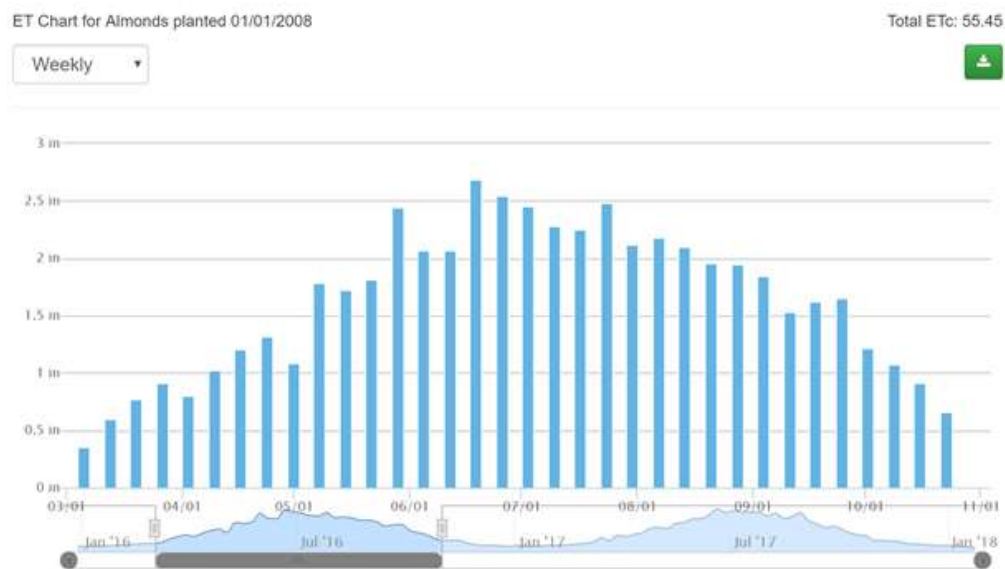

Source: PowWow Energy

3.3.3 Validate Schedule with On-Farm Sensors and Aerial Images

Once ET-based irrigation scheduling has been implemented, on-farm soil sensors and aerial imagery can provide a safety net by monitoring fields for signs of crop stress and verify that neither too much nor too little water is being applied. The frequency and duration of the irrigation was adjusted in July 2016 to keep the lighter soil area moist across the root zone (Figure 34). Optimizing water uptake and reducing deep water percolation can lead to improved yields and water savings, therefore improving the water use efficiency of the farm.

Figure 34: Validation of Irrigation Schedule with Soil Probes (Left) and Aerial Images (Right)

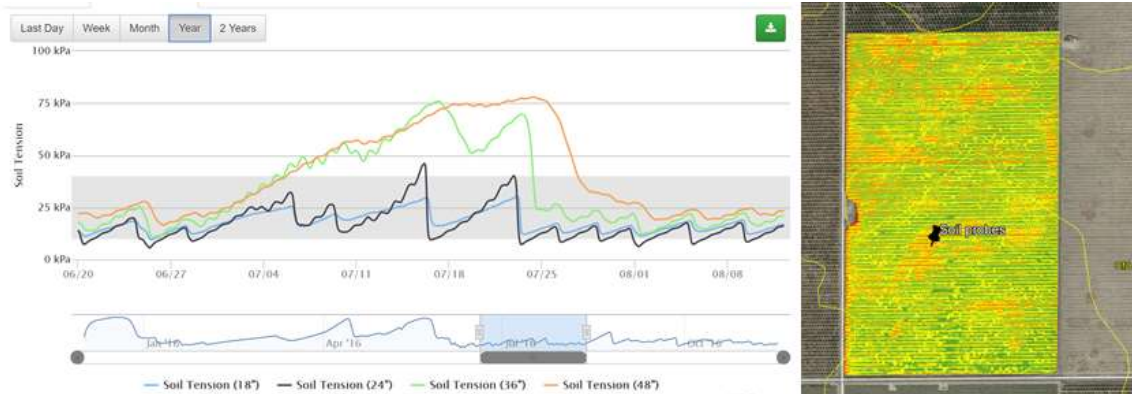

The plots in different colors correspond to soil tensions at different depths. The more frequent the irrigation cycles are, the moister the soil stays at three feet that corresponds to the root zone of a mature tree. This is typical of a lighter soil such as sandy loam. The location of the soil sensor is overlaid on top of an aerial image colored according to a vegetation index calculated from pictures taken at different wavelengths. The green areas are more vegetative; the yellow are less vegetative. The location of the sensor is in a lighter patch of soil according to the NRCS records represented with the yellow contours.

Source: PowWow Energy

3.3.4 Option: Deficit Irrigation During Drought

In times of drought, farmers face difficult decisions. The main goal of the project was to make the implementation less difficult. PWE provided the farms the ability to choose the target irrigation schedule based published DIL levels and proven trials. Figure 35 shows a partial ET irrigation schedule for a similar almond orchard as the one monitored in Figure 33. Note the drop in water application in the early part of the summer. This can save water without negatively impacting yield if it is implemented correctly, as described in Section 3.2.1.1.

The user interface provided by the PWE platform makes it as simple as clicking on a button, but it is critical for the farms to choose a stress metric to track the implementation of the deficit strategy in the field. ET is no longer the reference, and it is important to establish a safety net.

Figure 35: ET Schedule for a Mature Almond Orchard Near Tulare

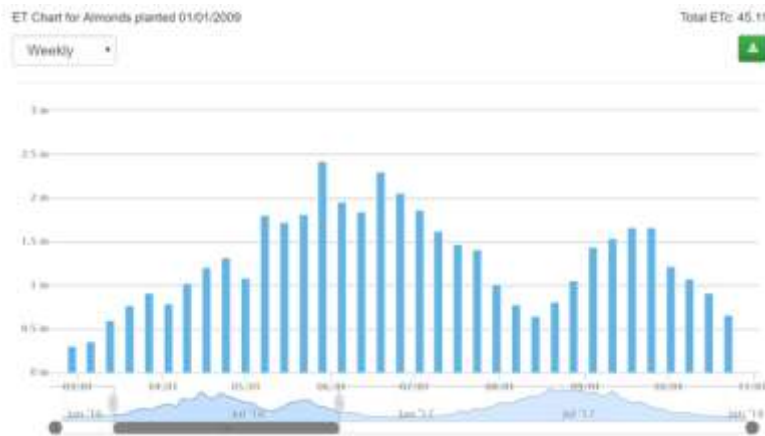

Source: PowWow Energy

The project team noted three approaches during the project:

- Plant based approach: there are target SWP values for certain crops such as almonds. In the early part of the season and after harvest, the SWP values should be between 4 and 8 bars below the baseline that depends on temperature and humidity.
- Soil based approach: the soil moisture should be higher during vegetative growth and lower during maturation. However, it is difficult to calibrate the sensor to compare the sensor readings to the theoretical Field Capacity (FC) and Maximum Allowable Depletion (MAD) levels.
- ET based approach: the amount of actual ET (ET_a) can be compared to the reference ET (ET_o) at different part of the season. This requires more data computation by the vendor to provide a simple indicator to the grower because the two values vary every day.

Aerial images can also be useful to verify the overall health of the field. Under irrigation or over irrigation can cause the trees to be more susceptible to pest attacks and diseases. This is why PWE integrated monthly images part of the Irrigation Advisor product to provide a quick view.

In summary, the illustrations provided by PWE in this sub-section provided an example of implementation of the fundamental four steps to optimize irrigation scheduling, from simpler to more complicated. Those steps can be implemented differently by various service providers or crop advisors.

CHAPTER 4: Data Integration to Support Vendor Neutral Platform

The project team identified in the previous chapter all the sources of data that must be collected in order to compute an optimized irrigation schedule. One of the challenges in the farming sector is the lack of standards. There is no equivalent to the Green Button standard to share data in a standard format. This has been, and continues to be, an obstacle to adoption of new technologies. For instance, there are more than a dozen methods to measure soil moisture and there are dozens of vendors. Each vendor has to work with the farming community to provide training and perform field trials before their sensor can be accepted. From the growers' perspective, each farm has to entertain different solutions based on fundamentally different concepts before deciding to use one of them.

As a result, a goal in this project was to provide a vendor-compatible platform that focused on providing the necessary information to run the pumps in the field (Figure 36). Farms shared with the project team that they did not have time to open multiple web-based applications at the office, and that they would rather receive simple information in the field via texts or emails.

Figure 36: PowWow Energy's Vendor-Compatible Data Platform

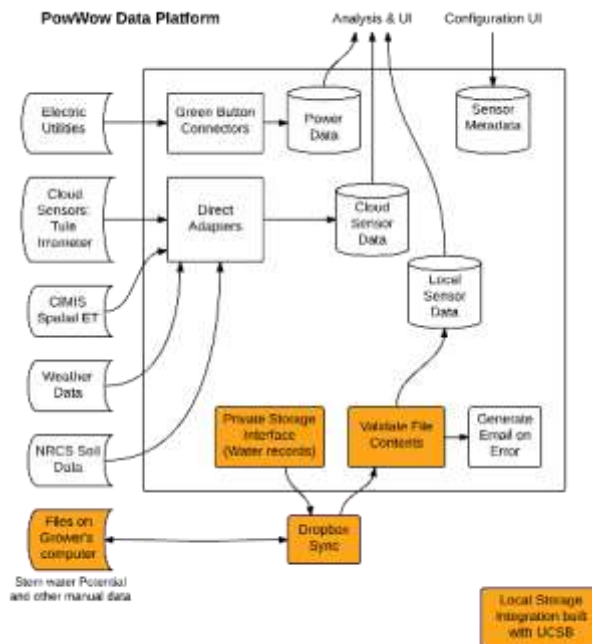

The data platform adapts to provide a vendor agnostic environment that will give growers access to all the data they need in one place. This includes the ability to integrate existing data collected manually in a spreadsheet via a shared "DropBox" folder to provide privacy protection.

Source: PowWow Energy

PWE in collaboration with UCSB integrated all the sources of data with a common interface and without changing the final format of the irrigation schedule at the end. PWE and UCSB continue to promote Application Program Interfaces (API), and some interfaces were developed by UCSB during the project. The project team reviews in this chapter, the main activities led by PWE and the Computer Science Department at UCSB.

The availability of APIs has improved since the beginning of the project, and UCSB was able to secure additional funding from the National Science Foundation to continue to work on more advanced data integration and privacy protection.⁷⁹ Interns during the EPIC funded project took part in the first hackathon for agriculture that was organized in 2015 in Coalinga with the support of California Public Utility Commissioner Catherine Sandoval and Robert Tse of the USDA. Also, PWE hosted a workshop called *Open Farm*⁸⁰ in October 2017 to promote open source architecture and better collaboration in the industry for scalable implementations in farming. It was organized in collaboration with the higher education system in California: University of California, California State University Fresno, and West Hills Community College. More information is provided in Chapter 8 about the workshops.

4.1 Weather Data

There are several sources of weather data that can help schedule irrigation. Historical ET values from CIMIS are particularly useful to plan for the coming season. National Weather Service (NWS) released a new service during the course of the project; it provides a weekly forecast of ET for a number of stations across the United States. Private weather stations can augment the density of locations. Vendors such as DTN Progressive Farmer provide relatively accurate precipitation and temperature forecasts for any location. Possible heat waves during the summer and rainfall before harvest are particularly important to track, as they can ruin a crop. Weather remains the primary source of data that a farm relies on and checks regularly.

4.1.1 California Irrigation and Management Information Service (CIMIS)

The project team not only integrated the hourly ET₀ data from CIMIS stations, the team also integrated the daily ET₀ data from the Spatial Data service from CIMIS. It provides reference ET₀ information for any latitude and longitude in California. It interpolates the information from the three closest CIMIS stations, and it leverages radar images from satellites. Further information is available on the website of CIMIS.

The daily data is made available to PWE via two different APIs:

- The Station API provides a complete weather report: precipitation, temperature, humidity and wind speed. With this data, CIMIS estimates the ET₀ at the station;

79 National Science Foundation. CyberSEES: Type2: *SmartFarm - Research and Education for Sustainable Agriculture Practices*. www.nsf.gov/awardsearch/showAward?AWD_ID=1539586. Accessed 12 Feb. 2018.

80 Pollock, D., 2017. *Data integration critical to maximize farm productivity, resource efficiency*. Western Farm Press issue of October 30, 2017. www.westernfarmpress.com/technology/data-integration-critical-maximize-farm-productivity-resource-efficiency.

- The Spatial CIMIS API interpolates between stations to provide an estimate of ET₀ for a specific location.

4.1.2 National Weather Service (NWS)

NWS has released recently an API separate from its forecast website to support a number of applications. PWE integrated the data, and the API is available at <https://api.weather.gov>.

The historical and forecast data from CIMIS and NWS are presented on a single chart to growers as illustrated in Figure 37. The data can also be downloaded with a “green button” for special projects at the farm.

Figure 37: Integration of Historical ET₀ Data (Spatial CIMIS) and Forecast Data (NWS)



Source: PowWow Energy

4.1.3 DTN – The Progressive Farmer

The project team also wanted to be able to measure rainfall for Measurement and Verification (M&V). Indeed, an increase in rainfall can lead to a reduction in irrigation that is not due to optimization of the farming practices. Once the soil profile is filled, there is no need to irrigate. The team also wanted to provide a basis weather service for any field in California. Growers check weather regularly, and it is easier to have all the information in one place.

During the project, the team explored the most accurate rainfall forecasts available. It was a task beyond the scope of the project, so the team relied on existing studies. The service from DTN-Progressive Farmer (DTN) is independently ranked the highest by Forecastwatch.com.

As a result, the project team integrated the data service of DTN as illustrated in Figure 38. PWE displays historical data and forecasted data. DTN leverages radars in addition to a network of weather stations. The team tested the accuracy of the data service by placing a weather station at one of the deployment sites. The team recorded temperature and rainfall. As an example, Table 12 summarizes the results for one week. One-week and one-day forecasts are compared with the measurements from the data service (radar) and the station (gauge). The results that show the one-week forecast can have a significant error while the measurement of the data service (radar) is close to the reading on the physical station (gauge).

Figure 38: Integration of Rainfall Forecast (Left) and Measurement (Right) for One Site

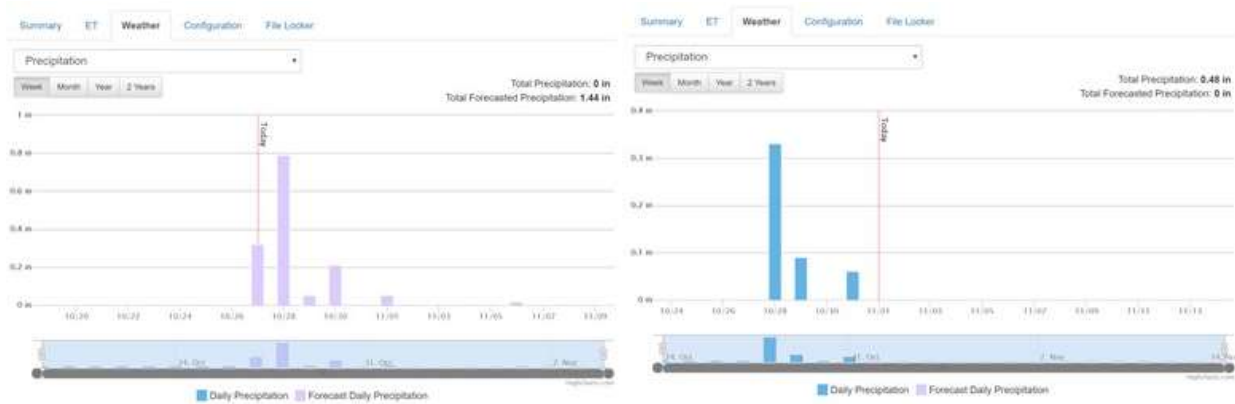

Source: PowWow Energy

The take-away is that it provides a reasonable reference to rainfall over a growing season for M&V purposes. Yet, the weather forecast is not accurate enough on a weekly basis to skip an irrigation event. If it does not rain later in the week, the field might fall behind schedule. Growers can take into account rainfall from the past week for the following week. Forecast remains essential because the risk of rain can have important consequences before harvest.

Table 12: Comparing Precipitation Data from the DTN Service With Weather Station Measurements

Date	Precipitation one-week forecast (inch)	Precipitation one-day forecast (inch)	Precipitation same-day estimate (inch)	Actual measurement (inch)
October 27, 2016	0.32	0.32	0	0.10
October 28, 2016	0.79	0.72	0.33	0.42
October 29, 2016	0.05	0	0.09	0.01
October 30, 2016	0.21	0.07	0	0
October 31, 2016	0	0.07	0.06	0.01
November 1, 2016	0	0	0	0
November 2, 2016	0.05	0	0	0
Total	1.42	1.18	0.48	0.54
Error	+0.85	+0.61	-0.06	

One-week forecast, one-day forecast, same day estimate (radar), and physical measurement (gauge).

Source: PowWow Energy

The project team also compared the accuracy of the temperature measurement of the data service because a heat wave can have severe consequences during the summer. This occurred at

one of the sites during the summer of 2017. The data correlated very well, with an R-squared value over 0.9. The project team actually found that the data service was less noisy than the weather station. Data is cleaned up at the network level. DTN also provides a map that can be useful to manage multiple ranches.

4.2 Aerial Images

There is currently a lack of standards for using aerial images as readily available data for farming. Normalized Difference Vegetation Images (NDVI) cannot be compared across season because the weather conditions affect the pictures. Also, the pictures are not registered with sufficient spatial accuracy to track a specific part of a field. However, the proliferation of sources of aerial images (satellites, fixed-wing planes and drones) has greatly reduced the cost of imagery per acre in recent years, making it scalable and attractive to farming. The project team provides a review in this sub-section how PWE implemented advanced analytical tools and machine learning algorithms to fill the gap between raw images and useful agronomic data.

The most commonly used image in agriculture combines visible and near-infrared photographs into an NDVI index. An example is shown in Figure 39.

Figure 39: Example of NDVI Image for an Almond Orchard in San Joaquin Valley



Source: PowWow Energy

With proper use of aerial imagery, farmers can pursue irrigation reduction strategies more precisely because growers can see the effect of the irrigation schedule across the entire field, not just at one location that the farming staff inspects manually.

In Figure 40, an overview of the steps involved to import aerial imagery into the PWE software application is shown. Each month, an aerial imagery vendor conducts flights and acquires imagery in multiple color bands of interest. The vendor provides an approximate geo-referenced footprint of that image. PWE acquires this imagery and applies processing to perform precise geo-registration, color correction, and calibrated NDVI calculation. These steps are essential to make month-to-month or year-to-year comparisons and track the evolution of the field. The resultant images are then displayed in the software-as-a-service (SaaS) application as a health indicator, on a field-by-field basis and indexed by time.

Figure 40: Processing Steps to Integrate Aerial Images Used Reliably in the Field

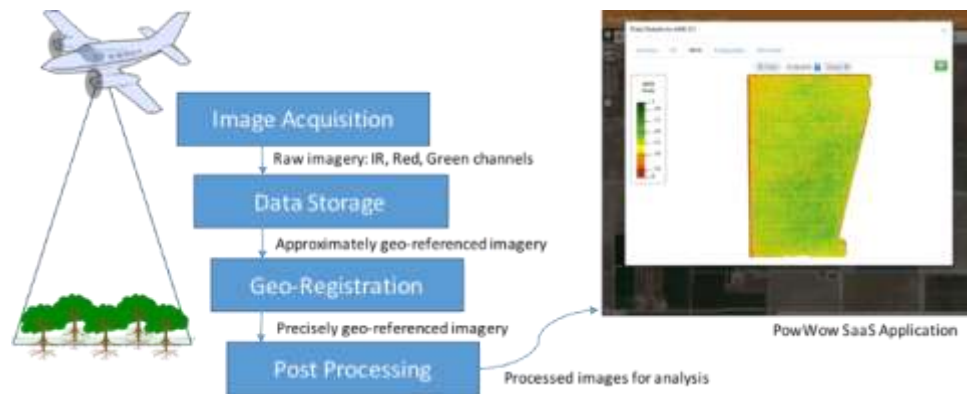

Source: PowWow Energy

4.2.1 Multi-Spectral Images

PWE examined multiple imagery vendors to assess their ability to provide high quality and timely imagery in California. The image processing pipeline is designed to be vendor-neutral, however some assumptions about the imagery provided are necessary to build a general framework for image integration. Following is a description of the nature of the imagery the project required, based on the interactions with multiple commercial imagery vendors, and describe some of the machinery the project team have built to integrate aerial images from a particular vendor.

Commercial vendors provide consistent, high-resolution imagery over most of California's farmland. Imagery collected over time is consistent if it is taken of the same field, at approximately the same time-of-day, and with the same imaging geometry specifically the center of the field of view and the camera position and angle should be similar for each photo. While PWE has developed algorithms to mitigate perspective effects that occur when processing imagery of varying consistency, the project achieved best results when images are consistent.

Another factor the project team considered when looking at an imagery vendor is the ground sample distance of the entire system. The ground sample distance is determined by the resolution of the focal-plane array, the field-of-view of the camera lens, and the viewing geometry (primarily altitude) of the camera system with respect to the imaged field. An example system might use a twin turboprop (Figure 41) that flies regular flight lines and takes pictures at predefined GPS coordinates. Indeed, there are vendors that have covered nearly all farms in the Central Valley in such a way for the past seven years. Flights are at a consistent altitude of 28,000 feet and at a speed of 285 knots.

Figure 41: Example Twin Turboprop Aircraft for Capturing Imagery of Farms



Source: GeoG2

An example camera system is shown in Figure 42. This camera system consists of four nearly identical focal-plane arrays and lenses, differing only in the filtered wavelengths (colors) of light. The cameras are stabilized by a gyro and contain controllers that synchronize the time at which they take a picture. The controllers are connected to a processor that triggers a photo to be captured at a number of preprogrammed GPS coordinates. A given flight line passes through a set of GPS coordinates and results in a set of pictures. The GPS coordinates are specified so that consecutive images will have approximately 50% overlap in their respective fields of view.

Figure 42: Camera System Mounted in the Belly of the Aircraft



Four cameras mounted in the belly of the aircraft hooked up to controllers that synchronize the image capture.

Source: GeoG2

These cameras have a 34-degree by 26-degree field-of-view and a focal-plane array resolution of 7216 by 5412 pixels. At typical altitudes, the imagery has a ground sample distance of 24 inches per pixel, which corresponds to approximately 28 square pixels on the canopy of a mature almond tree. This resolution is a good compromise between facilitating analysis and mitigating data throughput requirements.

It was expected of vendors to provide several color bands of imagery information. Vendors will typically provide channels realized by an image with a near-infrared (NIR) filter, a red filter, and a green filter, respectively, as well as a color image with a Bayer pattern filter containing red, green, and blue filters for capturing traditional color images (Figure 43).

Figure 43: Four Images Captured NIR-band, Red-band, Green-band, Color-bands (RGB)

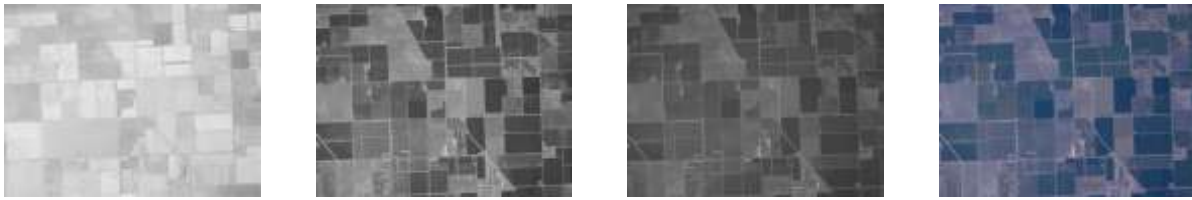

Source: GeoG2

The channels are first registered to one another in a process called “band-to-band registration” that corrects very-small misalignments between the respective images. After aligning the images to each other, they are collapsed into a single image for further processing (Figure 44). The project required at least NIR and Red channels and for the image bands to be registered.

Figure 44: NIR, Red, Green Channels Combined Into Single Color Image



Sensed NIR-band energy is shown in red, sensed red-band energy is displayed in green, sensed green-band energy is shown in blue. A false color image is shown as a combination of red, green, and blue.

Source: GeoG2

4.2.2 Geo-Registration and Calibration

4.2.2.1 Consistent Geo-Registration

In addition to the wavelength band requirements, the project also required that the delivered imagery is approximately georegistered, with registration errors on the order of tens of meters. These kinds of registration errors are typical. PWE then leverages machine learning algorithms to improve the georegistration accuracy to be on the order of a few meters.

In Figure 45, the geo-registration process of the project is outlined. The process can be divided into two parts. The first step is a one-time setup that occurs with the first image of a new site that the project team would like to monitor. Manual processing facilitates the availability of high-accuracy reference imagery. The second step occurs on a regular basis, perhaps weekly or monthly, and is done automatically. The coarsely geo-registered imagery is used to locate a precisely geo-registered reference image. The project team then align the new image with the reference image to obtain a high-accuracy geo-registered image.

Figure 45: Overview of Geo-Registration Process

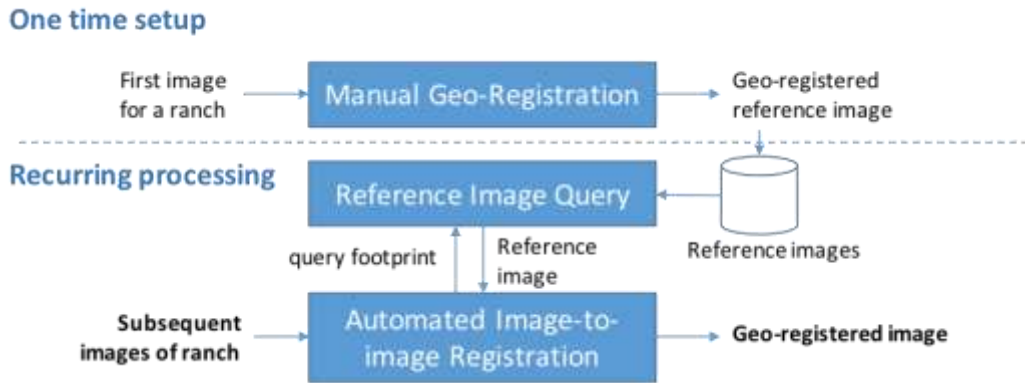

Source: PowWow Energy

To achieve accurate geo-registration for the reference image for all subsequent images, PWE does a one-time geo-registration by overlaying the image in a base map (PWE selected Google Earth) and adjusting the coordinates of the four corners until accurate (< 5 m) registration is achieved. PWE has an image processing pipeline that automatically processes batches of new images provided by imagery vendors. The images that are provided are already approximately geo-registered, i.e., have the coordinates of the four corners of the images in geodetic coordinates. The geo-registration accuracy of incoming images is good enough for the team to lookup a corresponding reference image that is in correspondence to the incoming image.

PWE implemented a module that takes a set of query images and examines a database of reference images to find the corresponding reference image with a Field of View (FOV) that best overlaps the FOV of the query image. However, images taken from a moving camera at two different times are never perfectly aligned. That is, the coordinates of the same landmark will be different in the two images. Therefore, PWE implemented a feature-based image registration technique and integrated into the processing flow. It has proven to be very accurate. The incoming image is warped so that it overlaps the reference image almost perfectly (< 2 m error). An example is provided in Figure 46.

Figure 46: Feature-Based Technique for Geo-Registration of Aerial Images

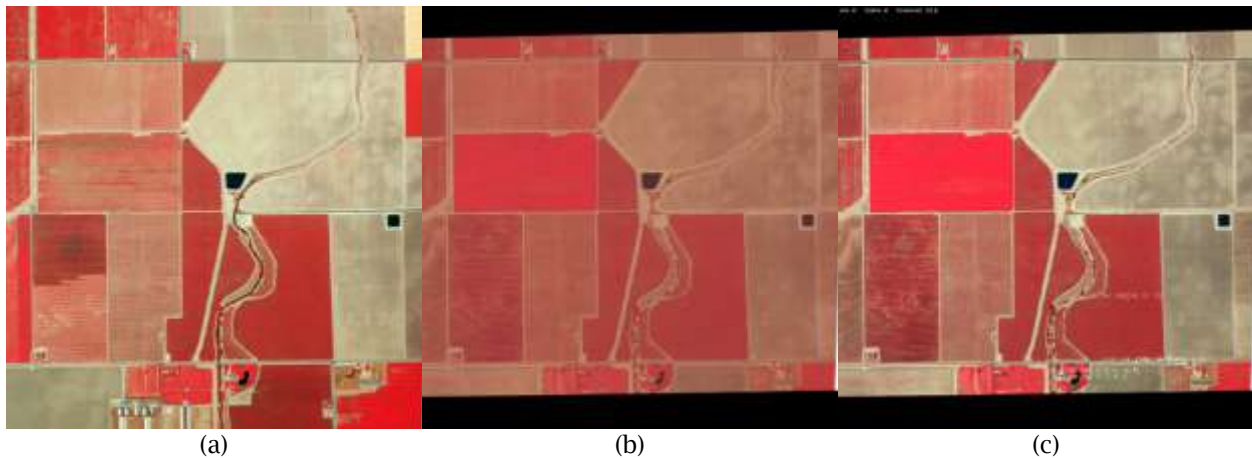

(a) Reference image is calibrated. (b) Incoming image *registered to the reference image*. Geospatial features (roads, reservoirs, structures, etc.) are all in the same location. (c) Current image registered and calibrated to the reference image. Colors of static landmarks are corrected.

Source: PowWow Energy

4.2.2.2 Optical Calibration

In Figure 47, an overview of the calibration procedure is shown. Like the georegistration procedure, it has a one-time setup for a new site. During the one-time setup, a high-contrast reference image is created. New images are subsequently processed automatically by a regularly recurring procedure. A high-contrast reference image is obtained and the colors in the new image are corrected so that static objects in the new image match the static objects in the reference image.

Figure 47: Overview of Calibration Process

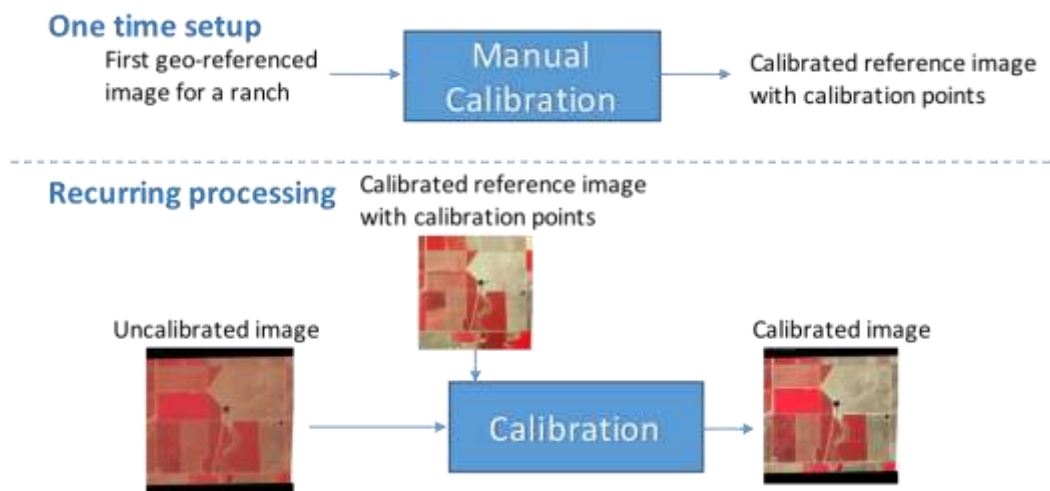

Source: PowWow Energy

The reference image will be the baseline against which all subsequent images are evaluated. Further adjustments are made to the exposure, brightness, etc., in such a way that it produces

an informative, high-contrast NDVI image. The images are processed so that the apparent lightness of all roads and structures is relatively consistent from site to site. Figure 48 (a) shows the raw NIR, Red, and Green channels obtained from the imagery vendor. The project team adjusted the colors to be consistent with other imagery and to show a visually higher level of contrast. In Figure 48 (b) the reference image that is manually calibrated is shown.

Figure 48: Calibration of Aerial Image

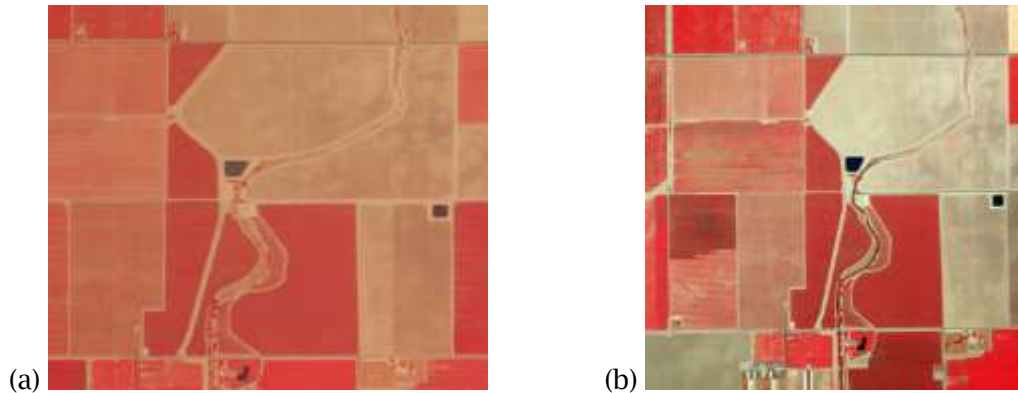

(a) Uncalibrated reference image. (b) Manually calibrated reference image.

Source: PowWow Energy

In addition to adjusting the colors of the reference image, a set of static landmarks that should not change color over time are also identified. Examples of such landmarks include tops of buildings and roads. These points will be used to calibrate new incoming imagery by keeping the colors of these landmarks constant.

As can be seen previously in (a) and (b), the apparent lightness difference between the calibrated reference image and a newly acquired incoming image can vary dramatically. For two unprocessed images taken at different times, lightness is affected by time of day, cloud-cover, perspective, and sensor gain. Without a meticulously controlled setup, two images taken at different times will almost never have the same exposure. To compare the images, they must not only be registered, but the image intensities must also be calibrated as well.

Accurate color calibration is important for several reasons. The most important is that it allows a grower to view images over time and to detect small changes that would otherwise be hidden. It essentially allows an “apples-to-apples” comparison between month-over-month images. Image calibration is a well-studied problem in photography. Indeed, many photo-editing software products have a “white balance” capability that allows a user to fix colors in a photo by clicking on a gray-point in the image. Professional photographers often use a “calibration card” to calibrate colors in an environment prior to a photo shoot. PWE has developed an automated calibration method based on similar principles. Figure 46 (c), shows a calibrated image, applying the automatically discovered calibration model to the image in Figure 46 (b). Notice how the colors of static landmarks, such as buildings, roads, are much closer to the reference image than they are in the uncalibrated image. The project team also rendered the chosen calibration points and their (R, G, B) values, along with the differences between the

predicted and actual reference values for each color plane. The error values are small, within 7% of the dynamic range.

4.2.3 Standard Output Formats

4.2.3.1 Normalized Difference Vegetation Index (NDVI)

Live green plants absorb solar radiation in the photosynthetically active spectral region, which they use as a source of energy in the process of photosynthesis. Leaf cells scatter solar radiation in the near-infrared spectral region because the energy level per photon in that domain is not sufficient to be useful to synthesize organic molecules. A strong absorption at these wavelengths would only result in overheating the plant and possibly damaging the tissues. Hence, live green plants appear relatively dark in the visible region and relatively bright in the near-infrared, as can be seen in Figure 49, which shows the typical reflectance sensitivities for plants. This phenomenon motivates the NDVI equation:

$$NDVI = \frac{(NIR - VIS)}{(NIR + VIS)}$$

Where *NIR* represents measured energy in the near-infrared region and *VIS* represents measured energy in the visible region, typically limited to the Red band. NDVI values range from -1.0 to 1.0 and are typically displayed using a false-color map that shows NDVI values associated with vegetation in green, while non-vegetation is shown in red.

Figure 49: Typical Reflectance Sensitivities for Different Spectral Wavelengths to Leaf Pigments, Cell Structure, and Water Content

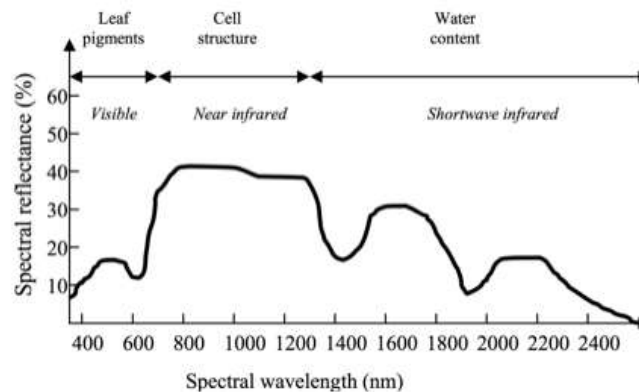

Source: Govender *et al.* (2009)⁸¹

Figure 50 shows a close-up on an example NDVI image of an almond orchard. Notice areas of high canopy show up in green and areas where there is only dirt or road show up in red.

81 Govender M., Dye P.J., Weiersbye I.M., Witkowski E.T.F., and Ahmed F., 2009. Review of commonly used remote sensing and ground-based technologies to measure plant water stress. *Water SA*, 35: 741-752 <http://dx.doi.org/10.4314/wsa.v35i5.49201>.

Figure 50: Example NDVI With False Color

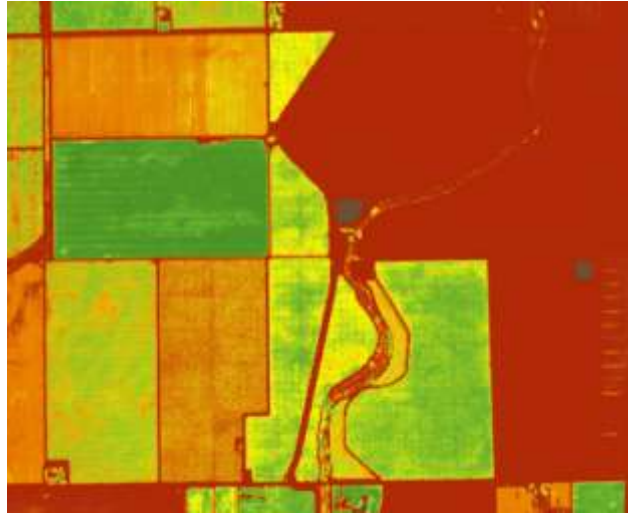

Vegetative regions are shown in green and non-vegetative regions in red.

Source: PowWow Energy

This image contains multiple fields and it is difficult to make field-by-field assessments given the wide diversity of crops. Different fields appear to be at different levels of health, but those differences are primarily due to crop type or orchard age. Each field would better be analyzed in isolation from the other fields as described in Section 4.2.3.2.

NDVI values range from -1 to +1 and are usually rendered with false-color. The color scale can be changed. In Figure 51, three different color maps are shown. The first is a simple greyscale map that shows larger NDVI values as white and lower NDVI values as dark. Trees show up brighter than the dirt. In the center another color map that renders dirt as red and vegetation as green is shown. In the third color scale is a heat map with higher NDVI values showing up in orange and red. PWE's software can accommodate any color scale.

Figure 51: Closeup of NDVI Image of Field With Three Color Maps

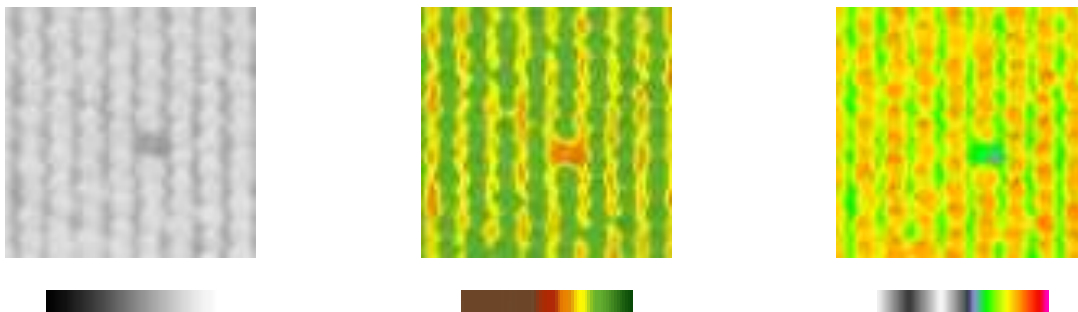

A mix of tree canopy and ground can be seen. The range of NDVI values is represented with three different color scales.

Source: PowWow Energy

4.2.3.2 Field Image Extraction

Using the field shape files drawn in Google Earth or provided by the grower, and using the geo-referenced, calibrated NDVI image, PWE’s software can automatically crop out each of the grower’s fields (Figure 52). This is done automatically on PWE software platform from the shape files entered by the grower to delineate the fields on the farm. For ease-of-use, only the NDVI pixels that are on the interior of the field are extracted and mark all other pixels as “transparent”. This occurs as part of the automated image processing chain.

Figure 52: Examples of Extracted Fields

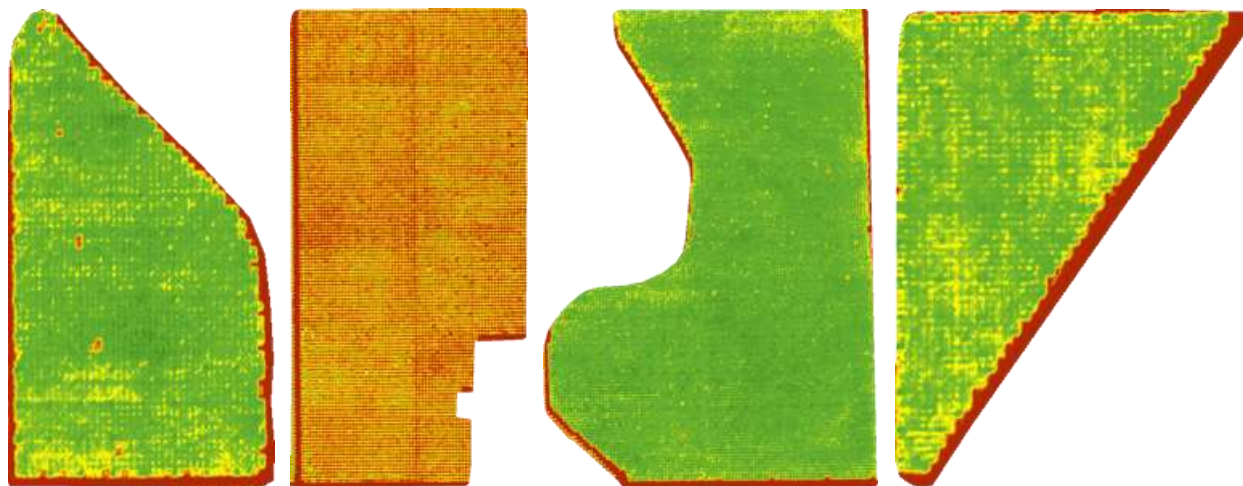

These images have a transparent layer as well as a geodetic footprint, allowing them to be embedded in GIS software such as Google Earth.

Source: PowWow Energy

The extracted image files can be further processed to create files suitable for embedding in GIS software such as Google Earth (kmz format) or embedded software for smart phone (GeoPDF format). The processing pipeline can optionally create these images as byproducts to be used in the field with smart phones, or to be analyzed in advanced Geospatial Information Systems (GIS) such as ArcGIS. In Figure 53, an example of NDVI images overlaid in Google Earth for a vineyard in California is shown.

Figure 53: Geo-Registered Field-Level NDVI Imagery of a Vineyard Overlaid in GIS Software

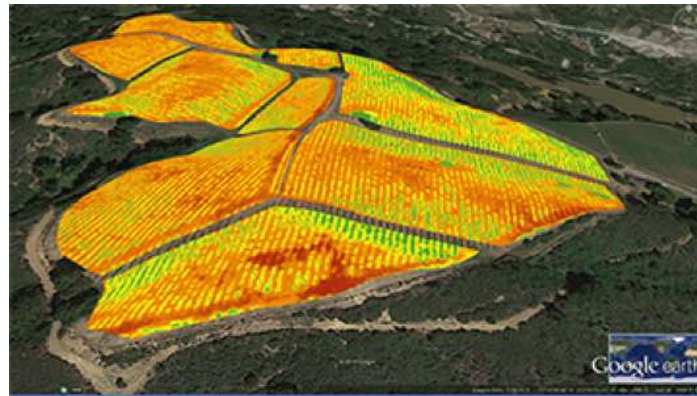

Source: PowWow Energy

Finally, the field-level NDVI images are uploaded to the PWE web application. An example of field-level NDVI water stress indication displayed in the web application is shown in Figure 54.

Figure 54: Web Application Display of Field-Level NDVI

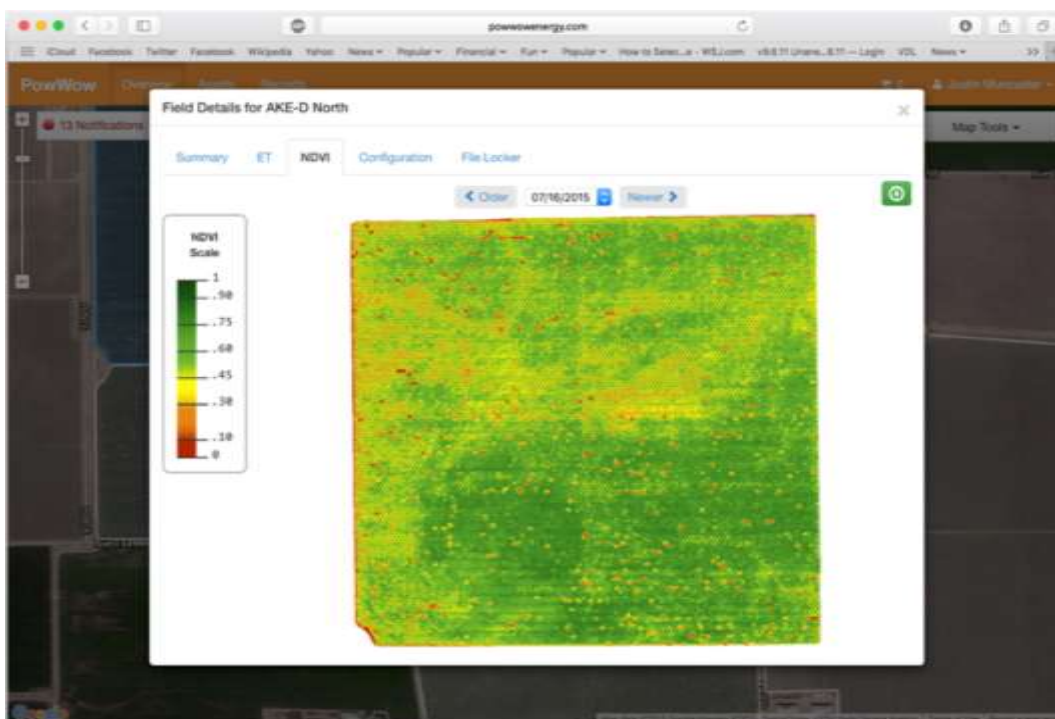

When the user clicks on a field, the web application shows field-level NDVI, which can be compared month-to-month or year-to-year.

Source: PowWow Energy

4.3 Examples of On-Farm Sensors

The vendor-agnostic data platform developed by PWE and UCSB standardizes the data from sensors into a small number of known types with specific semantics and meanings. For example, “temperature” can be stored in a standard way, regardless of how each data source

might provide the values. This standardization allows a common data storage methodology across a wide variety of sensor types. It also avoids some of the problems encountered by general “internet of things” data platforms where the sensor semantics are not known.

The basic approach is to build an adapter per source and store data in standardized ways. This allows the team to easily handle a variety of soil moisture sensor vendors and support different weather stations. The data architecture is summarized in Figure 55. The project team verified this approach by building adapters for several “on-farm” sensors” during the project. The vendors of the sensors typically provide telemetry and a way to retrieve the data on the Internet. It is not always the case as growers might use a handheld device such as a pressure chamber to record measurements manually and store them on a spreadsheet.

Figure 55: Generic Sensor Adapter Architecture

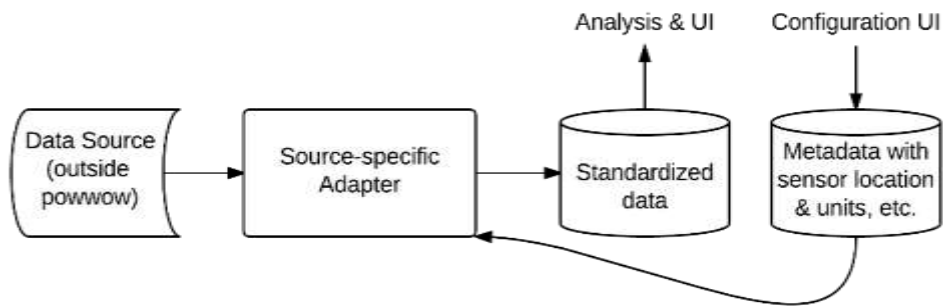

Source: PowWow Energy

4.3.1 ET-Based Sensor: Surface Renewal Station From Tule Technologies

Tule Technologies provides a telemetry station connected to a thermal sensor in a cage to measure the actual crop ET (ETa) based on the Surface Renewable method mentioned in Chapter 3. The device is particularly useful when the crop coefficient of a plant is not well known, as was the case for pistachio at site #1 (Figure 56).

Figure 56: ET Station From Tule Technologies at One Site



Source: Tule Technologies

The device can also be used to validate an irrigation schedule although it is not as easy to track a deviation from the amount of ET for a well-watered plant (ET_c). The project team found that comparing ET_a and ET_c value can give visual aid to see a trend that can lead to plant stress (*e.g.*, under irrigation) because the stomata of the plant will close and the ET_a value will go down compared to ET_c . However, the comparison is difficult to track, and it is difficult to set an alert. In contrast, the addition of a pressure switch sensor made it easier to compare application hours with planned hours from the schedule. ET_a data and irrigation events can be displayed in the web application developed by PWE as illustrated in Figure 57.

Figure 57: ET_a Data and Irrigation Events from Tule Technologies Telemetry Station

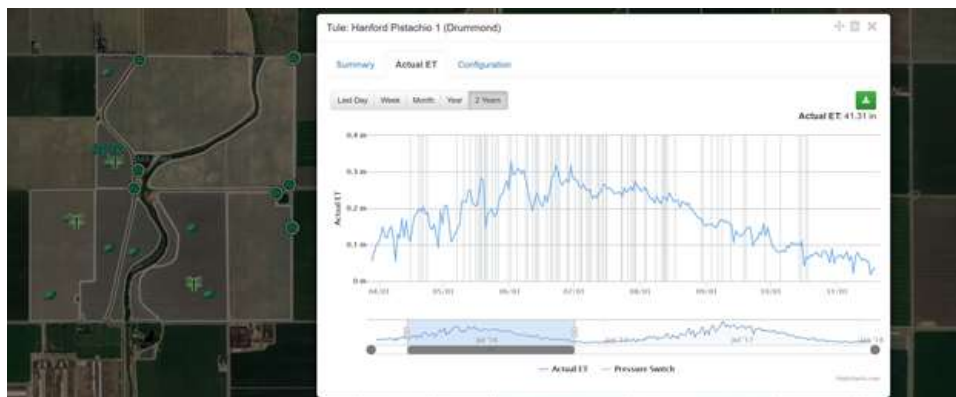

The daily amounts of ET_a are represented in blue (curve) while the irrigation events are in grey (bar).

Source: PowWow Energy

4.3.2 Soil-Based Sensors: Tensiometer From Irrrometer

The project team integrated several soil sensors, including tensiometers from Irrrometer and volumetric probes from Sentek. Farming staff can enter a new data provider on the PWE platform and insert the icon of the sensor to make it easy to look at the data with the rest of the information: pump data, weather data, and aerial images.

Soil moisture data are more difficult to interpret than ET data, but it provides a visual aid to track the movement of water in the soil at different depths. An Irrrometer station with tension probes was used at site #5. The variation of the soil-water balance measured in kilopascal (kPa) is tracked for three depths: 12, 24, and 48 inches (Figure 58). The field was flood irrigated, which limited the frequency of irrigation cycles to one between cuts. The level of tension assists the farm when irrigation is necessary to keep the root zone moist.

Figure 58: Tensiometer Data From Tule Technologies Telemetry Station

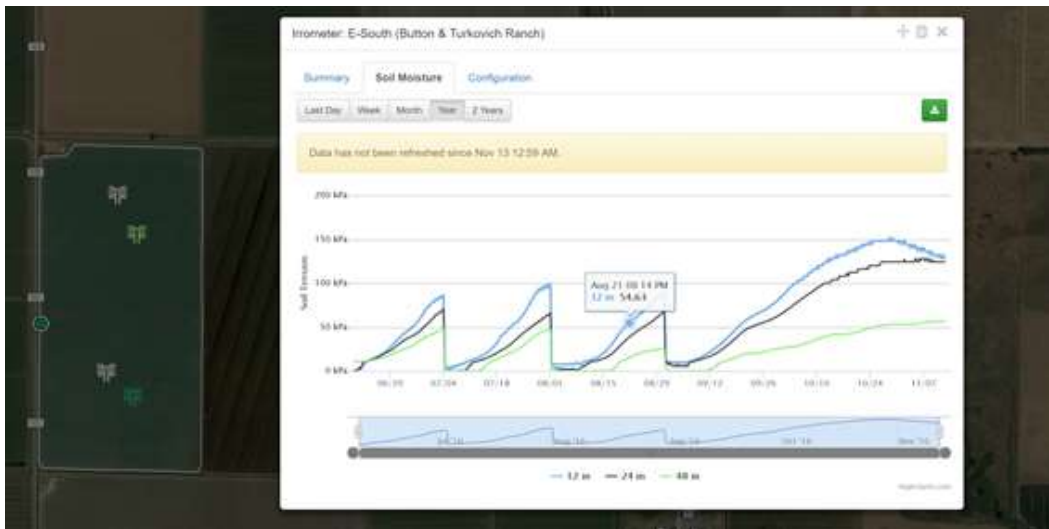

The tension levels for the three soil probes are represented in three different colors for depth levels of 12 inches (light green), 24 inches (black), and 48 inches (light blue).

Source: PowWow Energy

4.3.3 Plant-Based Sensor: Pressure Chamber

Using pressure chambers is common for a number of permanent crops such as almonds because target levels of tension in the plant (not to be confused with the tension in the soil) are known thanks to the research performed by Extension Specialists at UCD. For instance, tension should stay within 8 to 12 bars in the early part of the season (vegetative growth), while it should higher between 14 and 18 bars during maturation before harvest.

SWP measurements are labor intensive and typically written down on a sheet of paper. It is not a digital way of storing data for further analysis across a team, and decisions can be made in the field without fully understanding what the data means for the plant throughout the season. For instance, a pressure value of 12 bars in the spring does not mean the same thing in the summer. Therefore, PWE implemented a secure data sharing solution. PWE leveraged its architecture to provide a technology-agnostic method to store, process and plot manually

collected data. This was used at site #2 for almond trees. The data flow is shown in Figure 59. The same architecture can be used to integrate soil moisture data collected by neutron probes, which are still common.

Figure 59: Manual Data Shared by the Farm via a DropBox Folder Connected to PWE Server

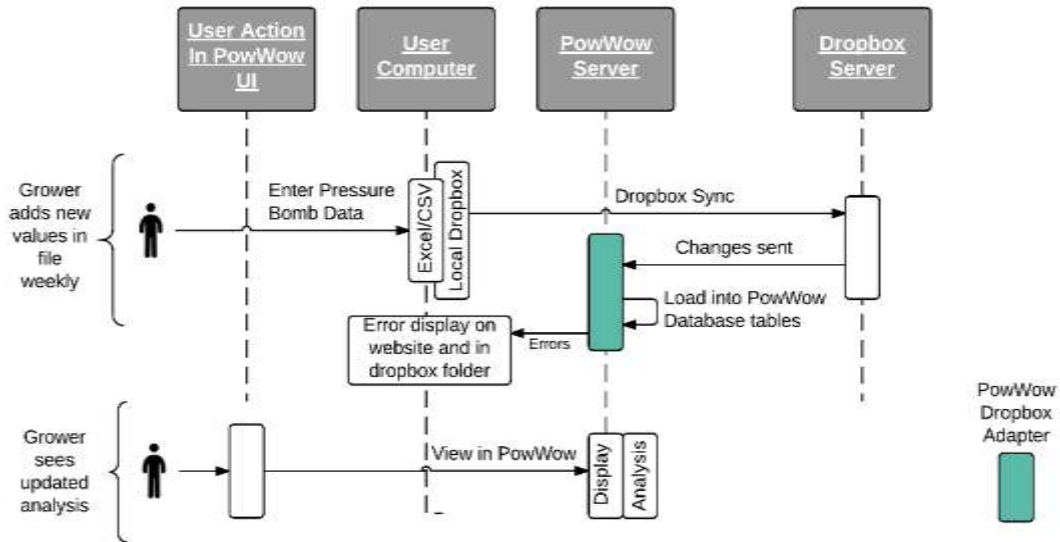

Source: PowWow Energy

In terms of user interface, the icon to click and plot the SWP data has a shape of a leaf as described in the left side of Figure 60. When clicked on, the history of the SWP measurements (black curve) is compared to the baseline (green curve) in a pop-up window as shown on the right side of Figure 60. This facilitates the interpretation of the data to make an irrigation decision against a target. Levels of stress in steps of 4 bars can be highlighted in different colors: no stress (green), moderate stress (yellow), and significant stress (red). Note that for this data representation, it does not make a difference if the data is collected manually or automatically by installing a telemetry station. The grower can see all the data at once and make comparisons.

Figure 60: Display of Stem Water Potential (SWP) Data via PWE Application

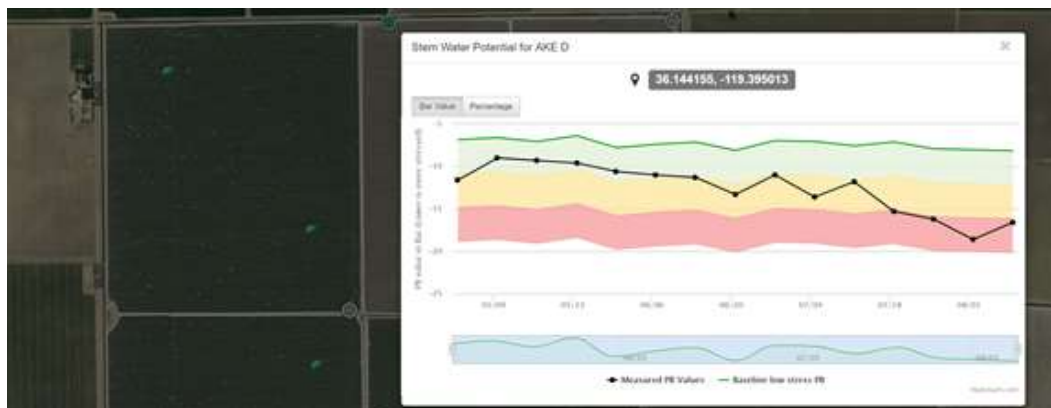

Source: PowWow Energy

CHAPTER 5:

Optimized Irrigation Software-as-a-Service

PWE's Irrigation Advisor was developed in conjunction with several large growers, crop advisors, and UCSB and UCD. The project team brought together the weather forecast, the irrigation system configuration, and current crop science to determine weekly recommendations for each field. Irrigation Advisor gives farms the ability to optimize irrigation schedules to achieve maximum profit. In a wet year, growers can decide to irrigate based on evapotranspiration (ET) to maximize yield. In a dry year, crop models allow them to save water by applying partial ET amounts at critical stages of plant growth without significantly affecting yield. This platform combines the Irrigation Advisor with PWE's Pump Monitor (which measures flow from groundwater pumps using data from IOU Smart Meters) and provides them as a "Software-as-a-Service" (SaaS). This allows growers and crop advisors to access their data and results via their web browser or a mobile phone. The project team delivered key messages and alerts via text message and email so growers can save time and stay focused on their crop and farm operations (Figure 61).

Figure 61: PowWow Irrigation Advisor Overview

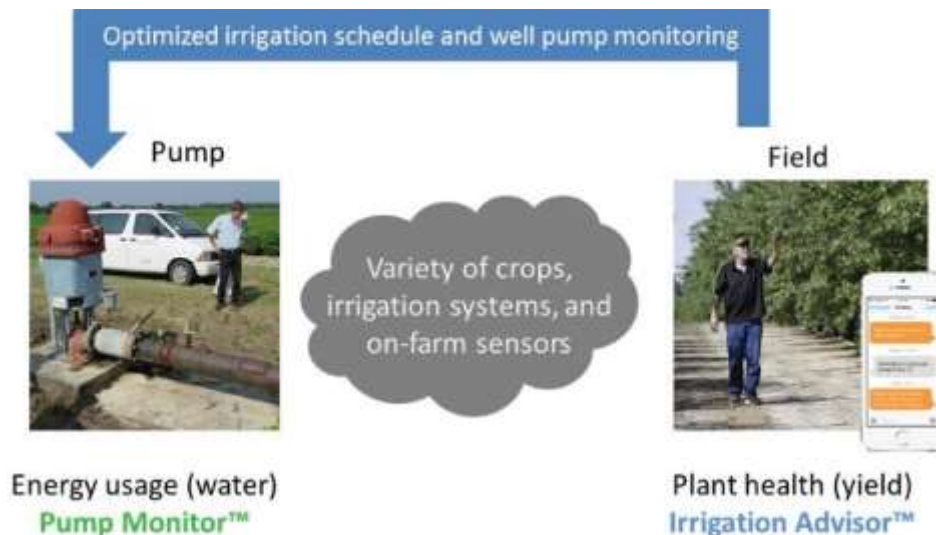

Source: PowWow Energy

5.1 Field Configuration for Irrigation Schedule

5.1.1 Configuration of Irrigation System

When setting up Irrigation Advisor to be used for a specific field, the first step is to define the field shape and crop. This begins by selecting the "add field" option in the "map tools" menu, then clicking to enter the outline of the field (Figure 62). Users can zoom in and out on the map to simplify entering the field shape and omit buildings or roads not being irrigated.

Figure 62: Entering Field Shape



Source: PowWow Energy

After the field shape has been entered and saved, the irrigation system parameters must be configured. This is done via a set of questions to be answered by the grower, which will be tailored specifically to different crops. For example, the following questions will be asked for pistachios and almonds, which are tree crops with similar irrigation characteristics:

1. What type of irrigation system is installed (drip, subsurface drip, microsprinkler, other)? This is used to set the default irrigation efficiency for the system.
2. What is the tree spacing? The project team used the tree spacing in the field to compute the number of trees per acre as part of computing the expected water use. This spacing varies widely, since best practices have shifted over the last 20 years. Many newer almond orchards have a tight spacing of 16x20, while older orchards may have trees as far apart as 20x24.
3. What is the water application rate of the irrigation system? Water application rate can be specified as gallons per hour per tree or as inches per hour. Both values are usually computed during irrigation system design. The project team recommends entry of inches per hour if known. If gallons per hour per tree is selected, the system will compute the inches per hour based on the tree spacing.
4. How many sets are in the field? Irrigation for larger fields often requires more water flow than is available from a single source. Such field may also have significant variations in soil type. In these cases, irrigation piping and valves are installed to create “irrigation sets,” allowing smaller portions of the field to be irrigated at a time. For example, a 160-acre field may have two irrigation sets of 80 acres. If six hours of

irrigation was required in a day, growers might first irrigate the west side from 6 am to noon, then the east side from noon to 6 pm.

Some larger fields need different schedules for each section. These fields should be created as smaller individual fields instead of one large field. For example, a single field on a slope may be irrigated in two sections and require longer irrigation on the upper section. This can be accomplished using a lower irrigation efficiency for the upper field.

A slightly different set of questions will be used to configure the irrigation system for tomatoes (and other vegetables) since tomatoes are usually planted on raised beds to allow the use of automatic harvesting machines:

1. What type of irrigation system is used (drip, subsurface drip, other)?
2. What is the bed width?
3. How many plant rows are in each bed? A single bed can be planted with one or two rows of tomatoes.
4. How many drip tapes are in each bed? Most often, if two rows of tomatoes are planted, there will also be two drip lines.
5. What is the water application rate? Water application rate can be specified as gallons per hour per 100 feet of bed or as inches per hour.
6. How many sets are in the field?

5.1.2 Crop Model

There are two basic irrigation approaches. The first is full ET, usually resulting in the best yield but using more water. In drought years, or to reduce disease risk, a grower can also use partial (or deficit) irrigation during certain phases of the plant's growth cycle. In either approach, the water required for a plant is calculated using crop coefficients (K_c). These calculations are described in detail in Chapter 3 of this report. The system is preloaded with recommended values of K_c for supported crops based on UCD research. For the 2016 season, the project supported scheduling for pistachios, almonds, and tomatoes. For pistachios and almonds, an age factor is also incorporated to reduce irrigation for young trees. Crop coefficients can be reviewed and adjusted per field if necessary. An example K_c table is shown for almonds, with partial irrigation enabled (Figure 63).

Different varieties mature at different rates and the weather in a particular season can affect maturation. For example, maturation may be slower than the historical average if the month of May is cooler than typical. The project team recommends a weekly review during the early season to fine tune the irrigation schedule. Adjustments to the "date this season" should be done BEFORE the date occurs so that it will be reflected in the irrigation schedule for the following week. For example, on April 25, it may look like the nut formation stage would start on May 4 instead of May 1. If this change is made, then the next week's irrigation schedule will be adjusted slightly based on the interpolated K_c value.

Figure 63: Crop Coefficient Table for Almonds with Partial Irrigation Enabled

▼ Crop Stages and KC - 2017 Season Bloom:

Use Partial Irrigation Scheduling *User-edited values are in blue with reference value in italics.*

Stage	Kc	Partial %	Date this season	
Bloom	0.40	100	02/16/2017	Forecast
Leaf out	0.41	100	03/02/2017	Forecast
Leaf out	0.63	100	03/16/2017	Forecast
Shoot growth	0.69	100	04/02/2017	Forecast
Shoot growth	0.75	100	04/17/2017	Forecast
Nut formation	0.82	100	05/02/2017	Forecast
Nut formation	0.88	100	05/17/2017	Forecast
Nut filling	0.95	100	06/02/2017	Forecast
Shell hardening	1.03	100	06/17/2017	Forecast
Hull abscission	1.07	75	07/02/2017	Forecast
Hull split	1.08	50	07/17/2017	Forecast
Hull split	1.07	50	08/02/2017	Forecast
Harvest	1.08	25	08/17/2017	Forecast
Harvest	1.07	50	09/02/2017	Forecast
Bud differentiation	1.05	75	09/17/2017	Forecast
Bud differentiation	1.00	100	10/02/2017	Forecast
Bud dormancy	0.91	100	10/17/2017	Forecast
Bud dormancy	0.86	100	11/02/2017	Forecast
Dormant	0.75	0	11/17/2017	Forecast
Dormant	0.64	0	12/02/2017	Forecast
Dormant	0.45	0	12/16/2017	Forecast
Dormant	0.40	0	01/01/2018	Forecast

Age: 10 years, KC Age Factor: % Restore Defaults

Reference data from: *Sanden 2007 for nonpareil*

Daily K_c values are interpolated between the values entered for the specified dates.

Source: PowWow Energy

Trees become dormant in the winter and use relatively little water. As a result, irrigation is rarely necessary before bloom unless it has been a dry winter. Once the field begins to bloom (Figure 64), the canopy grows quickly and the crop coefficient changes significantly in the first month (0.4 to 0.63). To avoid under- or over-irrigation, the grower must enter the bloom date as soon as it is observed in the field. This will shift the K_c table dates to ensure adequate irrigation (Figure 65). This adjustment for bloom data must be done every season. Note: Pre-season (before bloom) irrigation may be required to ensure the soil profile is fully loaded at the beginning of the irrigation season. This must be determined by field inspection or properly

working soil moisture sensors, since it will depend on many factors including the amount of winter rain, presence of a cover crop, and soil type.

Figure 64: Almond Orchard Blooming



Source: UC Davis

Figure 65: Bloom Date Has Major Impact on Water Required

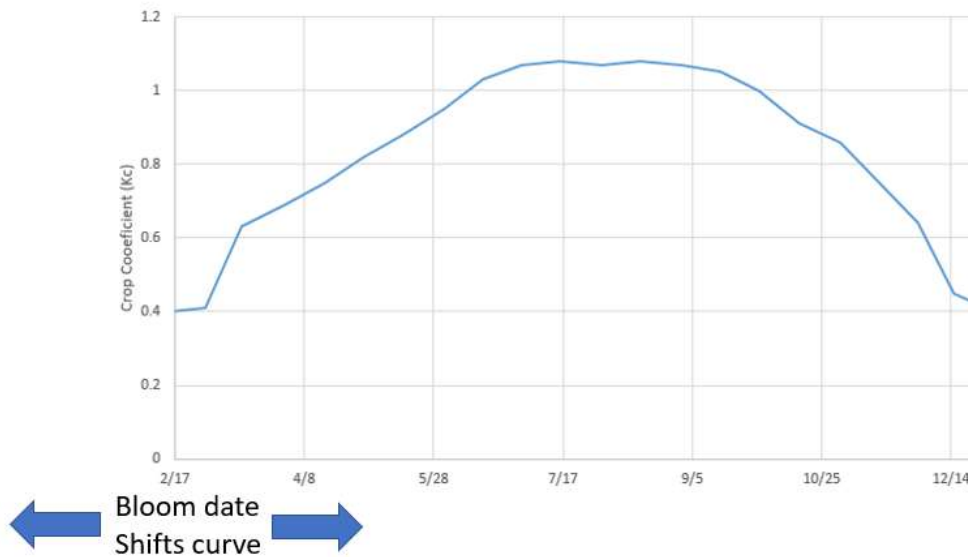

Source: PowWow Energy

Something similar is done for processing tomatoes, which are typically transplanted into the field sometime in February or March. Normally, a planned date is entered in the pre-season and then adjusted when the transplant occurred. Setting the transplant date shifts the K_c table dates as shown in the example given above for almonds.

5.1.3 Weekly Irrigation Schedule

The irrigation schedule for each field is computed each Monday morning using the available weather forecast data for ET and precipitation. The resulting irrigation recommendations for the week, expressed as suggested irrigation hours for the field, are shown in the user interface (Figure 66). System users can elect to receive a customized email message containing the weekly irrigation schedules for the fields within their ranches (Figure 67). The schedules are computed and sent early Monday morning so that they will be available to the field crews at the beginning of each week.

Figure 66: Suggested Irrigation Hours Display in User Interface



Source: PowWow Energy

Figure 67: Example of Email Message with Weekly Suggested Irrigation Schedules

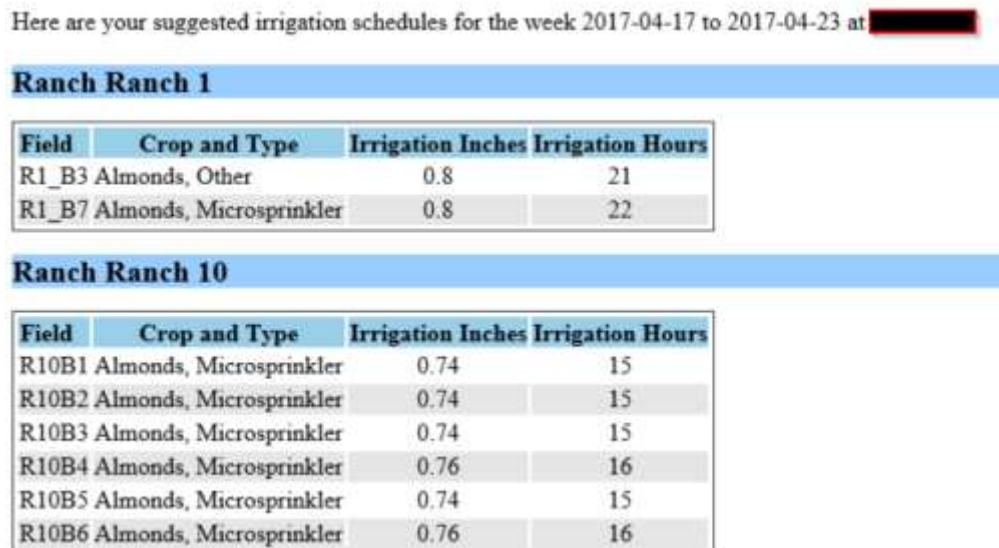

Source: PowWow Energy

5.2 Email Notification of New Imagery

5.2.1 Large-scale Image Processing

The Irrigation Advisor includes aerial imagery to help assess the development of the crop during a season (Figure 68). This is a critical part of monitoring the effectiveness of the changes in irrigation practices. After setting up Irrigation Advisor to be used with a new field, one year of historical images will be provided (growers must provide accurate entry of field shapes, as described in Section 5.1.1). During the growing season, one new image per month will be provided from April through September. The multi-spectral images are displayed with a color scale that is based on an index called the Normalized Difference Vegetation Index (NDVI). All images are retained to allow tracking of a field over its lifetime (Figure 68). Full high-resolution images are provided for use with iPhone navigation applications (via Geospatial PDF), display in Google Earth, or for display or printing (PNG). The high-resolution images allow zooming to observe individual trees in an orchard.

Figure 68: Aerial Imagery for a Ranch with Multiple Fields

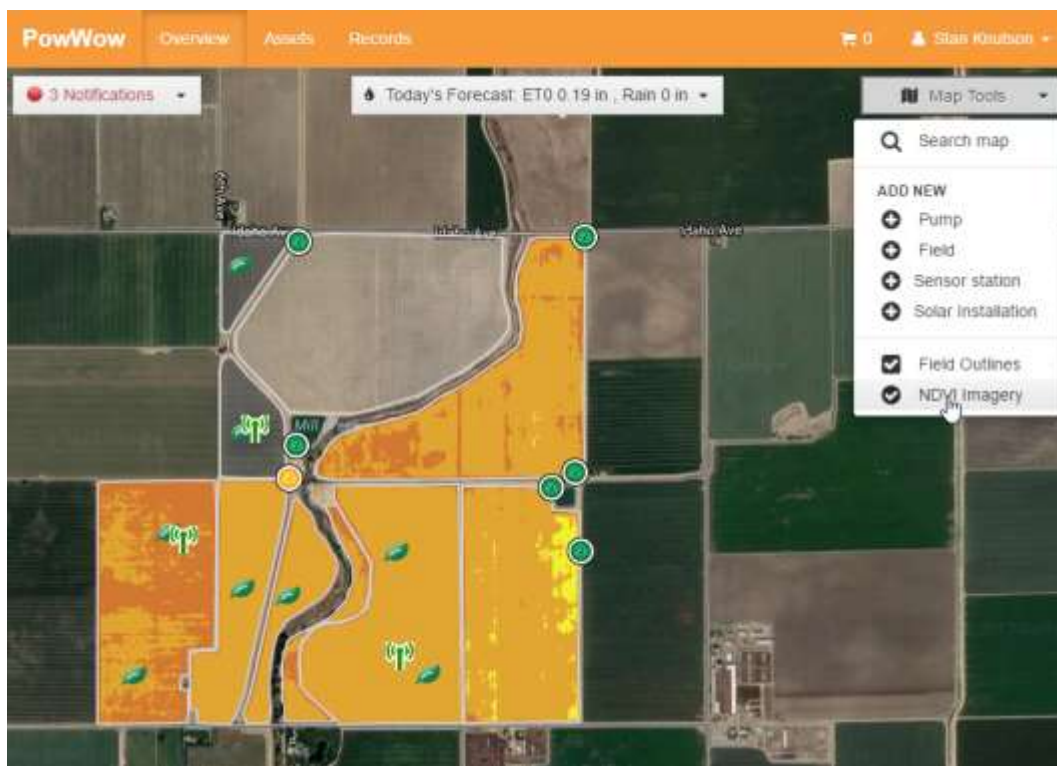

Source: PowWow Energy

Figure 69: Access for Field Images by Date

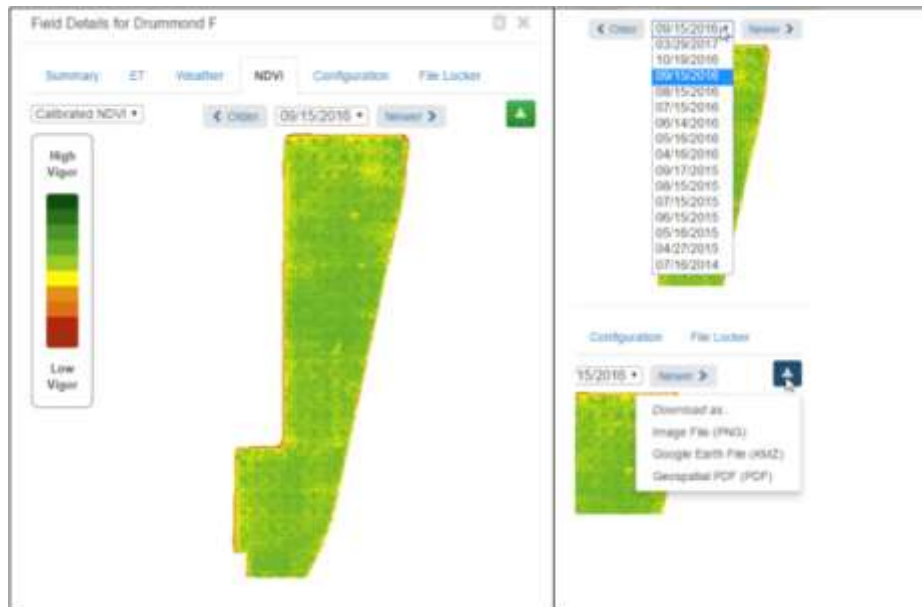

Source: PowWow Energy

5.2.2 Email Notification

Irrigation Advisor sends an email to the farming staff when new images are available (Figure 70). Each user can click on one of the field hyperlinks, which will redirect them automatically to the field on the web application. The one-click capability makes it very easy to check the latest status of the fields.

Figure 70: Email Notification That New Images are Available at a Ranch

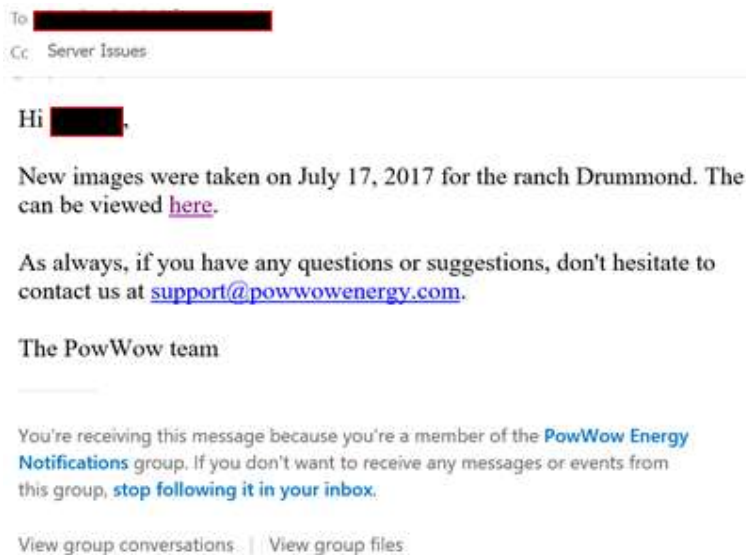

Source: PowWow Energy

5.3 Irrigation Optimization: “Closing the Loop”

After talking to farming staff at the various sites during the project, the project team realized that there would be a lot of value to “closing the loop” by comparing the actual amount of water applied on the fields against the amount specified by the ET schedule. It provides a simple way for ranch managers to check if the schedule is implemented despite the difficulty of adapting to a new work schedule. It also provides an opportunity to make adjustments the following week, in case it rained the prior week (more water) or if there was a conflict with a spraying event (less water), and ultimately achieve the best water use efficiency.

During drought years, there is also an additional challenge to implement finer schedules against targets that are more sophisticated and based on multiple data sets. The project team reviewed both scenarios in degree of complexity:

- Comparison of actual pump hours during one week and the ET schedule converted in hours. This was tested at the ranch level using Pump Monitor;
- Comparison of actual inches of water applied (irrigation and rainfall) with the ET or partial ET schedule. This was tested at the field level using Irrigation Advisor;
- Comparison of water stress target during the season against target ranges. This can be displayed under Irrigation Advisor for various sensors: ET_a , SWP, and soil sensors.

5.3.1 Comparing Water Application Against ET Schedule

Operations in the field boil down to practical decisions, such as when to turn the pump on and off. In the example below at site #1, the project team compare the number of application hours for two sets of fields that were irrigated with one booster, and the total of hours that the pump was on during the week of July 24 to 30 in 2017. The pump load varies with the field configurations but the hours can be added (Figure 71).

Figure 71: Comparison of Pumping Hours and ET Schedule for One Week at a Pistachio Orchard

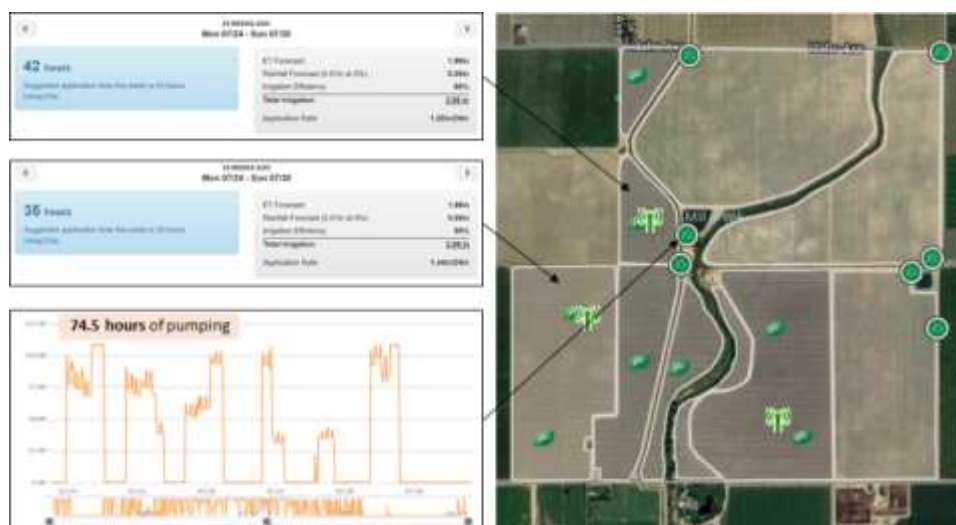

Source: PowWow Energy

The results show that the actual number (74.5 hours according to the smart meter data) is close to the desired schedule (42+35=77 hours according to ET schedule). This is a difference of less than 5%, which gives confidence that the schedule was implemented correctly. If the difference is too high (*e.g.*, >10%), the system can be configured to send an alert to the user.

Many of the sensors that PWE integrated during this project have a pressure switch to sense when water flows through the main irrigation line of one field. This provides a specific number of hours that can be converted into inches of water application. This can be compared to the planned schedule according to ET. In the example (Figure 72), the project team compared the actual water application and the ET schedule of one almond orchard in Northern California where rain plays a bigger role. Heavy rains early in the 2017 season (light blue) delayed regular irrigation until May (dark blue). The short cycles in March (dark blue) are for fertigation (application of nutrients via the irrigation system).

Figure 72: Comparison of Water Applied (Inches) with ET Schedule at an Almond Orchard

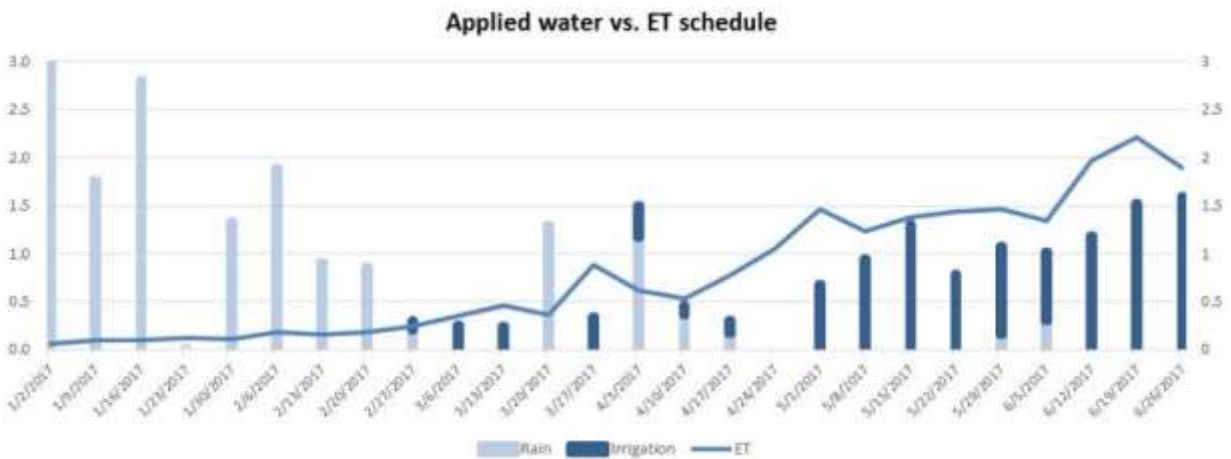

Source: PowWow Energy

The cumulative application of water can be compared and differences during a week (application vs. ET) can be taken into account for irrigation scheduling during the following week. The impact of rain is more difficult to assess because it depends on how much water is actually in the soil. This requires a soil-water balance model taking into account the soil type and other factors.

The two examples described above are simple management tools that can be implemented with Pump Monitor (pump hours) and Irrigation Advisor (inches), depending on the equipment and the precision that the farm desires to achieve. In a full-ET schedule, there is some forgiveness because the soil stores water and a farm can apply a bit less or a bit more water without hurting the crop. Adjustments can be made week-to-week in order to get back on schedule. In the example described in Figure 72, the amount of irrigation is increased in the last months of June to catch up with the increasing levels of ET that depend on the atmospheric pressure.

5.3.2 Tracking Deficit Irrigation Schedule Against a Target Value

Partial irrigation is a different story. In the period where moderate stress is targeted per design, there is a risk that too much water will be withheld and the crop will “crash”, especially during a heat wave in the summer. It is therefore important to track the level of plant stress in order to reduce water use without negatively impacting crop yield. A review of three approaches is described.

The first approach is based on a plant-based measurement. SWP can be measured with a pressure chamber, and compared to target levels at different stages of the season (Figure 73). This is most precise if reference values exist from peer-reviewed research from UC ANR.

Figure 73: Evolution of Stem Water Potential (Bars) During the Growing Season of an Almond Orchard Near Tulare



The SWP value should be in the green zone (no stress) most of the season. The goal is to gradually set SWP in yellow and red zone (moderate to significant stress) during hull split.

Source: PowWow Energy

The second approach is based on soil moisture to track the movement of water in the soil at different depths. The example is for olives (Figure 74):

Figure 74: Evolution of Soil Moisture in Volumetric Content (Inches) During the Growing Season of an Olive Orchard near Fresno

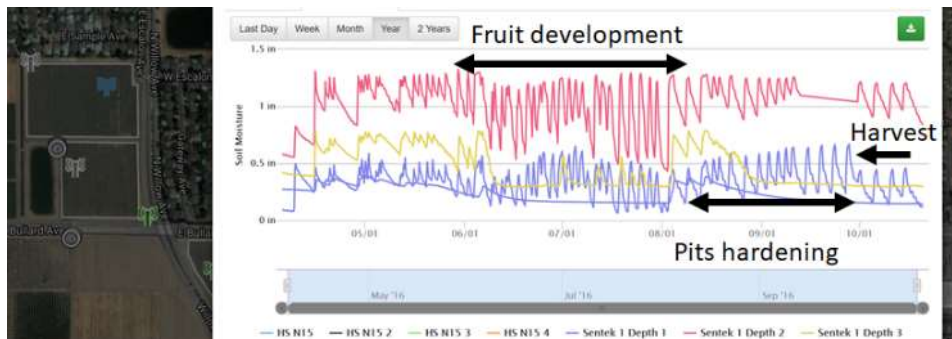

The SWP value should be in the green zone during nut filling (no stress). The goal is to gradually set SWP in yellow and red (moderate to significant stress) during hull split.

Source: PowWow Energy

The third approach is based on the actual amount of water transpired. It is related to the other two approaches but provides a different point of view. The stomata of a plant will close if there is a high atmospheric pressure but little water available in the soil. At that point the amount of actual ET (ET_a) will be smaller than the crop ET (ET_c) for a plant that was fully watered. In the example shown below for tomatoes (Figure 75), it shows that the values of ET_a are lower than the values of ET_c over most of the season. In the beginning of the season, however, there is an error in the crop coefficient -- the values of ET_c are lower than the values of ET_a , which is not valid because ET_c is supposed to represent the maximum value of evapotranspiration in an ideal scenario. This highlights the importance of manually adjusting the crop coefficient every week based on the canopy cover.

Figure 75: ET_a and ET_c Amounts (Inches) for a Tomato Field at Russell Ranch (UCD)

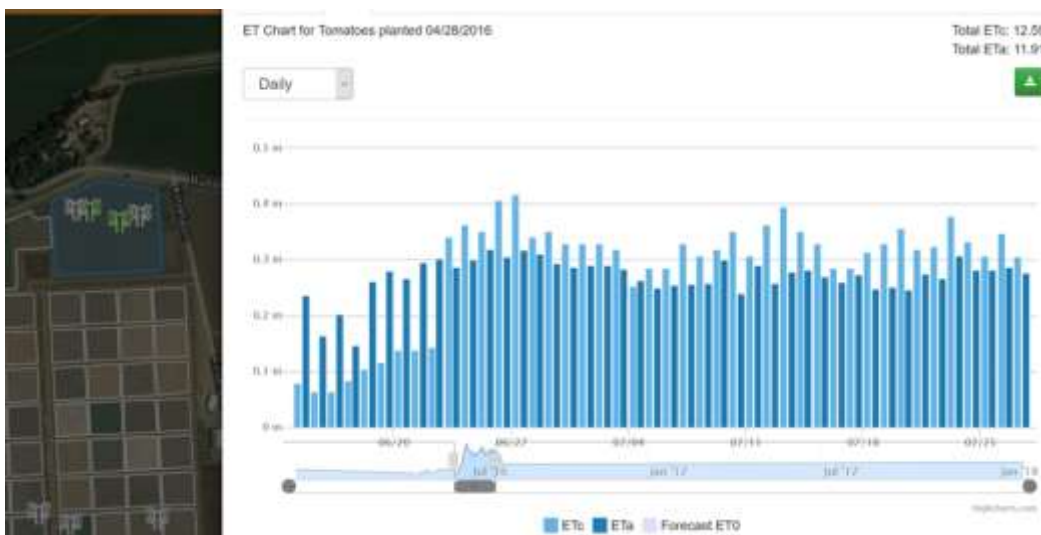

Source: PowWow Energy

It is difficult, however, to apply deficit irrigation without a reference. Most farms will apply deficit irrigation at a specific time during the season before harvest in order to increase the level of solid content or the quality of the fruit. This is a fourth approach, which is common for fruits such as grapes, tomatoes, and oranges. BRIX level is one of the common metrics measured to achieve the level of quality desired. In the case of tomato, this can save significant water because the processing tomatoes will be dehydrated anyway at the cannery to produce a paste for further processing (*e.g.*, ketchup). Figure 76 is an example from site #3, where several levels of deficits were tested.

Figure 76: BRIX Levels in Tomatoes Before (Blue) and After (Orange) Deficit Irrigation

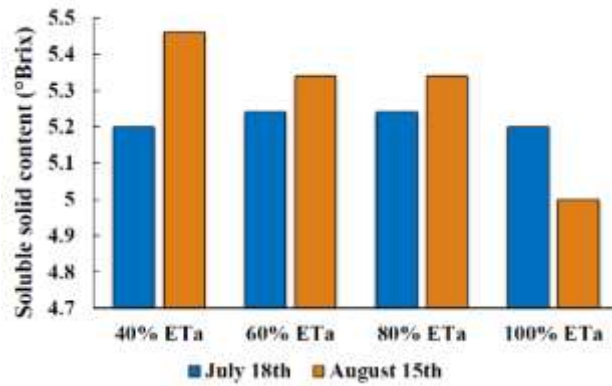

Source: University of California, Davis

Another example where the comparison between ET_a and ET_c values is more helpful is for a permanent crop, such as pistachio. It is difficult, however, to set a target for the ratio of ET_a to ET_c because ET_a levels vary greatly one day to the next depending on the timing of irrigation. The graphs below show the comparison of a pistachio under full ET (left) and under partial ET (right). The values of ET_a vs. ET_c vary in both cases. A linear comparison validates that the amount of ET_a is below ET_c for the partial-ET (right), and centered for full-ET (left) but not a straight line (Figure 77).

Figure 77: Comparison of Two Pistachio Fields Under Full-ET and Partial-ET Irrigation Schedules

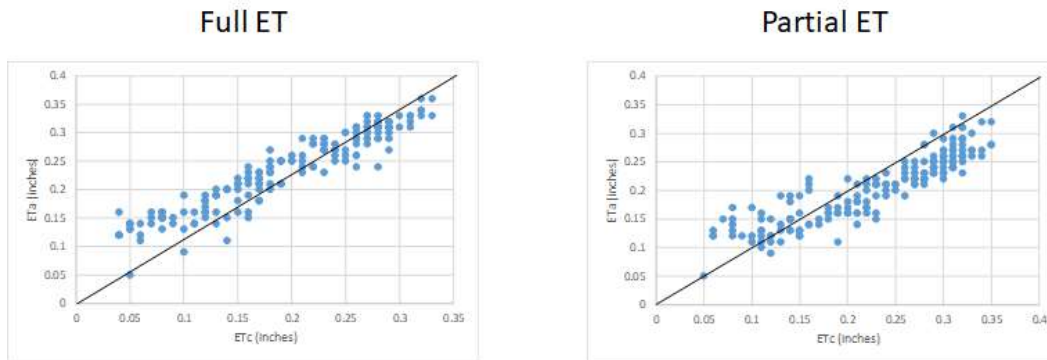

The values of ET_a vs ET_c vary in both cases. A linear comparison validates that the amount of ET_a is below ET_c for the partial-ET (right), and centered for full-ET (left) but not a straight line.

Source: PowWow Energy

As a result, the vendor who developed the ET sensor provides more analytics based on satellite images and the sensor data to compare the rate of transpiration against production targets. The color scheme provides a simple way to drive irrigation decisions (Figure 78).

Figure 78: Evolution of a Figure of Merit Called FieldStat by the ET_a Sensor Vendor

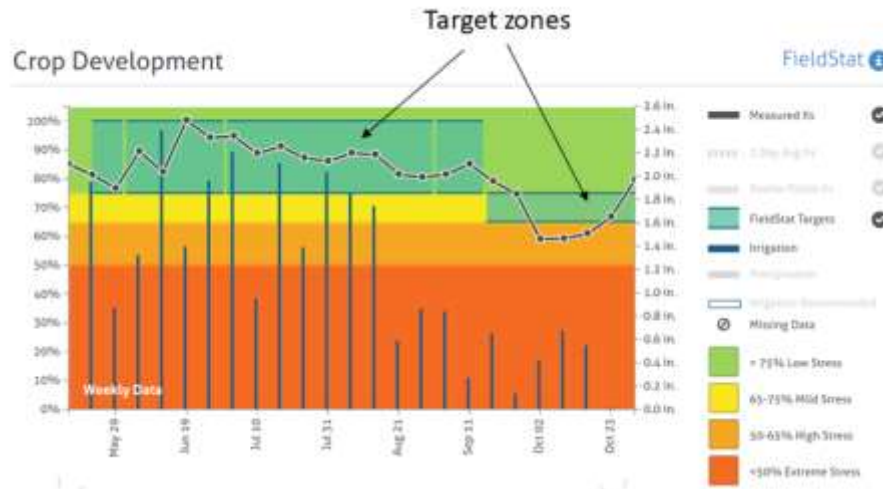

Target zones are clearly established to support irrigation decisions every week.

Source: Tule Technologies

Target zones can be set for the other approaches based on soil moisture or SWP if the references are known at different times of the season, as illustrated in Figure 73.

5.3.3 Managing Spatial Variability With Monthly Aerial Imagery

5.3.3.1 Integration of Thermal Image to Get a Snapshot of the Level of Water Stress

Thermal imaging is a technique that has shown promise in estimating plant water stress.⁸² Various studies have shown it to be more sensitive to water stress than techniques using Near Infrared (NIR) wavelengths commonly used for NDVI images. To account for variation in ambient temperature, a ratio of leaf surface temperature and air temperature is calculated.⁸³ Commercialization of water stress images is still underway because thermal cameras have lower resolution and more expensive. Ceres Imaging released a first commercial product in California. The correlation between stomatal conductance using thermal imagery and SWP measured for plants was studied at the UC Kearny Extension near Bakersfield (Figure 79). A correlation of 0.64 was reported.⁸⁴

⁸² Keinonen, I. and Jones, H., 2004. *Combining thermal and visible imagery for estimating canopy temperature and identifying plant stress*. Journal of Experimental Botany, Vol. 55, No. 401, pp. 1423-1431.

⁸³ Rodriguez, J., 2016. *We use aerial spectral imagery to optimize water and nitrogen*. Presentation provided as public comment at workshop organized by California Energy Commission on 11 Oct. 2016.

doCKETpublic.energy.ca.gov/PublicDocuments/16-OII-01/TN213953_20161011T084905_Ceres_Imaging_We_use_aerial_spectral_imagery_to_optimize_water.pdf

⁸⁴ *Ibid.*

Figure 79: Correlation Between Stomatal Conductance From Thermal Imagery and SWP

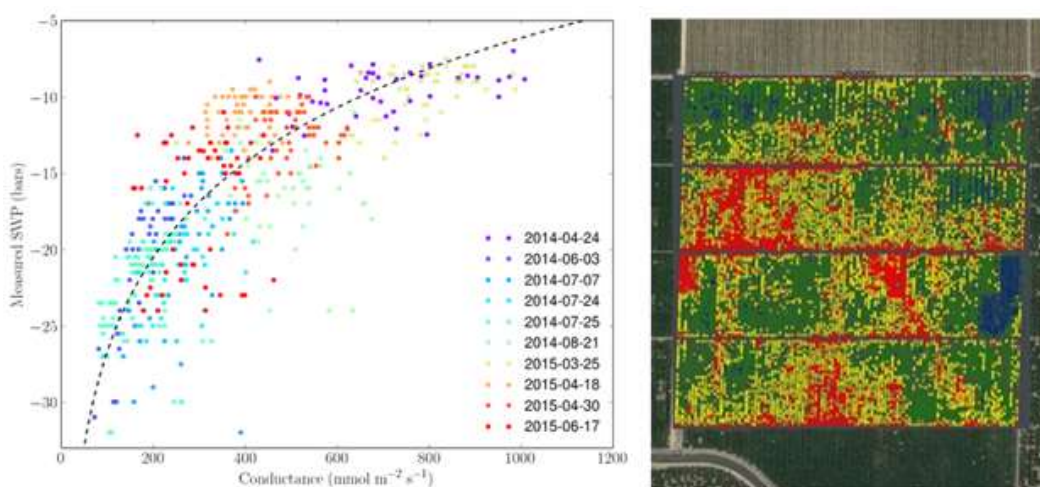

Estimation of stomatal conductance from thermal imagery is correlated to stem water potential (left). Values are converted to a color scale to create a map (right).

Source: Ceres Imaging

5.3.3.2 Development of a SWP Estimator Based on the Soil-Plant-Water Continuum

It is challenging to provide a stress indicator for every row, or even every single plant, in a way that relates to the fundamental principles of irrigation. There is no closed loop equation that takes into account the various factors that capture the subtleties of the evolution of a biological organism. However, it is possible to generate accurate estimators if provided with enough data by using machine learning algorithms. Machine algorithms are used today in medicine to identify malignant cells in images of patient to treat various types of cancer at early stages.

The project team tested the concept after the witnessing the change in growth curves for an almond orchard before and after the implementation of an optimized irrigation schedule. In Figure 80, the irrigation strategy was dramatically improved between the 2013-14 and 2015-2016 seasons. Thanks to the calibrated and geo-referenced images that PWE put in place, the team was able to generate growth curves for every single tree in the orchard over 4 years.

The health of the trees (vigor with increasing NDVI values) across the field was compared for the 2014 and 2015 seasons (Figure 80 - right). Also, the canopy of the trees grew where the trees were previously stressed (Figure 80 - left). This led to a significant increase in crop yield in 2015 (and again in 2016 - data not shown in this figure) for a small addition of water. In 2014, the field was under-irrigated in the first part of the season and over-irrigated in some areas during the second part of the season. The evolution of the vegetation index (NDVI) for each tree in 2015 follows the expected model of an almond tree (Figure 80 - bottom right). It grows (increase in the first part of the curve), then matures (reduction in the second part of the season), and finally grows again (bud differentiation for the next season after the harvest of the crop). This was not observed in 2014. The graph representation and the statistics confirmed, with a high level of confidence (thousands of growth curves vs. one data point), the need to adjust the irrigation schedule and to take into account the soil variability of the field.

Figure 80: Growth Curves of an Almond Orchard Generated From Near Infra-red Images

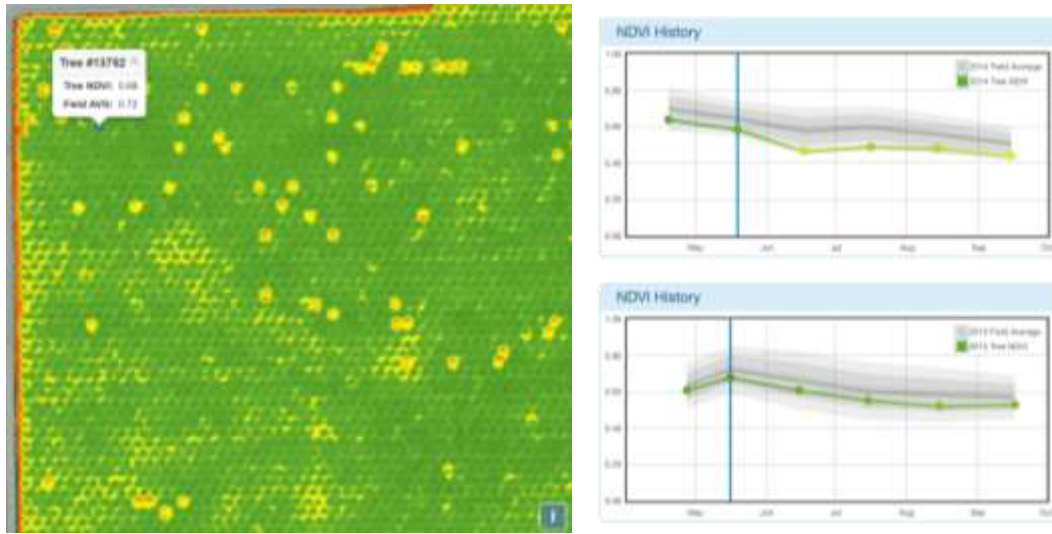

NDVI value is calculate for each tree (left). Growth curves are generated by plotting the evolution of the vegetation index across the season for 2015 and 2016 (right).

Source: PowWow Energy

PWE implemented the first machine learning implementation of the soil-plant-atmosphere continuum (SPAC). Each factor was captured: soil-water balance, tree physiology, and weather. PWE trained the model on historical data made available by commercial farms and experimental farms. The relative importance of each feature is summarized in Table 13.

Table 13: Relative Importance of Each Feature to Predict Stem Water Potential (SWP)

Feature	Relative importance
Baseline SWP (atmosphere)	0.3
NDVI (plant)	0.2
Water depletion (soil)	0.5

Source: PowWow Energy

CHAPTER 6:

Deployment at Six Sites Representing More Than 4,000 Acres of Farmland

The project team was fortunate to engage in early discussions with farms in Sacramento Valley and San Joaquin Valley. The crops that the project selected for use represent 2.4 million acres under cultivation and a mix of tree crops (almond and pistachio), row crops (tomato), and field crops (alfalfa). The farming sites were primarily in four locations: Davis, Fresno, Hanford, and Tulare. Two sites were in SCE territory, and four sites were in PG&E territory (Figure 81).

Figure 81: Locations of Project Deployment Sites



Site 1 is located in Hanford (King County), site 2 in Tulare (Tulare County), sites 3 and 4 in Davis (Yolo County), site 5 in Winters (Yolo County), and site 6 in Helm (Fresno County).

Source: PowWow Energy

This section describes the experiments performed to evaluate the water and energy savings that are made possible by using the decision-support tool described in Chapter 5. The project team talked to farm advisors and growers as well as UCSB and UCD, and found it was essential to integrate the level of performance (crop yield) to demonstrate convincingly that the technologies were ready to be scaled across California. The project team held discussions with Energy Commission staff at one of the quarterly Emerging Technology Coordinating Council (ETCC) meetings, and it was agreed that the level of performance should be considered. The analogy is that energy savings for light bulbs in a building is normalized to the level of luminescence (lumens per Watt). The Energy Commission updated the definition of Energy Efficiency as “the use of less energy to provide the same level of performance for products and services”. As a result, yield data was collected to compute improvements in percentage, but the data were kept confidential to respect the privacy of the farms. The following sub-sections summarize the experiments and the data collection.

6.1 Description of Experiments

The first two sites had only tree crops (almond and pistachio) while the three other sites had only row or field crops (tomato and alfalfa). The project team met with Terranova Ranch Inc. (site #6) during the project and decided to add them as a site because (1) they were performing a groundwater recharge project that was complimentary to the water measurement activity in Task 2; and (2) they had a mix of tree, row and field crops to further test the team’s decision-support platform.

6.1.1 Site #1 – Nichols Farms Near Hanford (pistachio)

The first site was near Hanford and encompassed two utility territories: PG&E (west of the stream) and SCE (east of the stream). This site had capacity issues during the drought because one of the wells was not working properly. The farm repaired one well in 2015, and there was not enough water to irrigate the fields at full ET that year. The description of the experiment in 2016, including the list of all fields, pumps and on-farm sensors, is shown in Figure 82.

Figure 82: Description of the Experiment at the Pistachio Fields Near Hanford

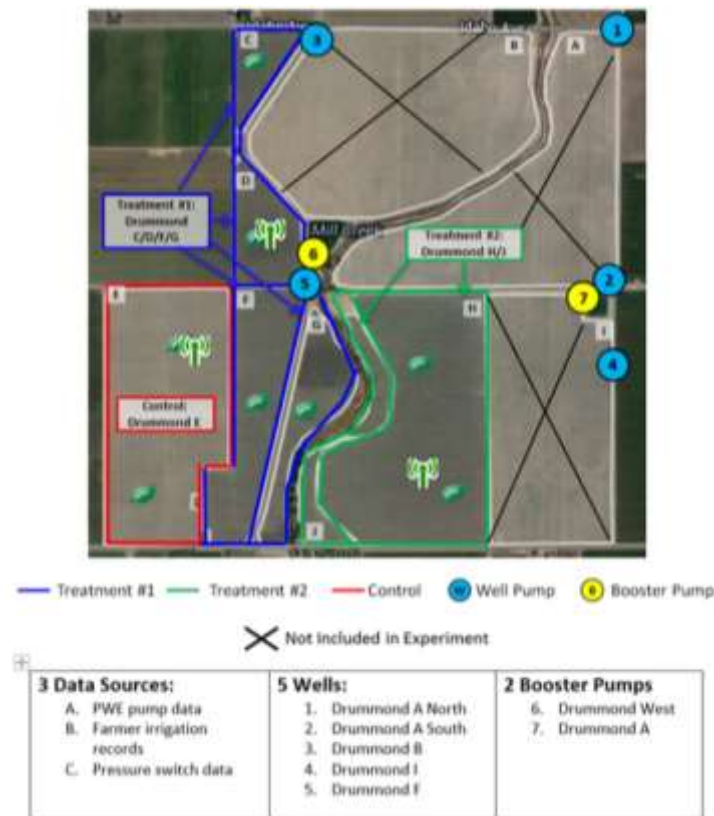

Source: University of California, Santa Barbara

6.1.1.1 Improvement of Pumping Plant Efficiency

The farm decided to fix the well Drummond-A-North during the 2015 season (hole in casing), during which time it was not used to feed the east reservoir. In 2016, Pump Monitor detected a

falling water table that reduced the efficiency of the pump and risked causing cavitation. The farm reacted by pulling out the bowls and inserting an extension of 40-feet (Figure 83).

Figure 83: Smart Meter Data in 2014 to 2017 for Well Pump Drummond A North



The farm received a text alert on August 8, 2016 and extended the bowls. Pump Monitor tracked the operating condition of the pump, and validated that the pump was back to normal on August 30, 2016.

Source: PowWow Energy

6.1.1.2 Improvement of Water Use Efficiency

Three ET stations were installed to measure ETa in each of the three areas. Three fields (A, B, and I) were recently planted and not part of the experiment (Figure 82). The goal was to implement a deficit of 20% at Drummond H/J and use Drummond C/D/F/G as a reference. The farming crew ended up swapping the fields because C/D/F/G fields are more difficult to irrigate. They were dealing already with limited capacity the prior year. The project team found that out by comparing the amount of water applied with the pressure switch connected to the ET station. The project team alerted the farm management, who then debriefed with the crew. The fields C/D/F/G showed signs of stress at the end of the season. In retrospect, the irrigation could have been better managed by providing a comparison of applied water against the plan every week during summer. This way, the farm management could have reacted before it was too late (*i.e.*, close to harvest).

6.1.2 Site #2 – Sierra View Farms Near Tulare (Almond and Pistachio)

The second site was located near Tulare and included both almond and pistachio orchards. The project team analyzed the 2014 data in detail before the 2015 season because the team wanted to conduct a three-year experiment on the impact of water stress. The ranch had multiple issues with disease in wet areas of the ranch and spider mite attacks in dry areas of the ranch. The ranch has a central reservoir fed by a number of well pumps (ground water) and lift pumps

(surface water). All the fields are irrigated from a set of three boosters that run various sets of fields (Figure 84).

Figure 84: Description of the Experiment at the Almond Fields Near Tulare

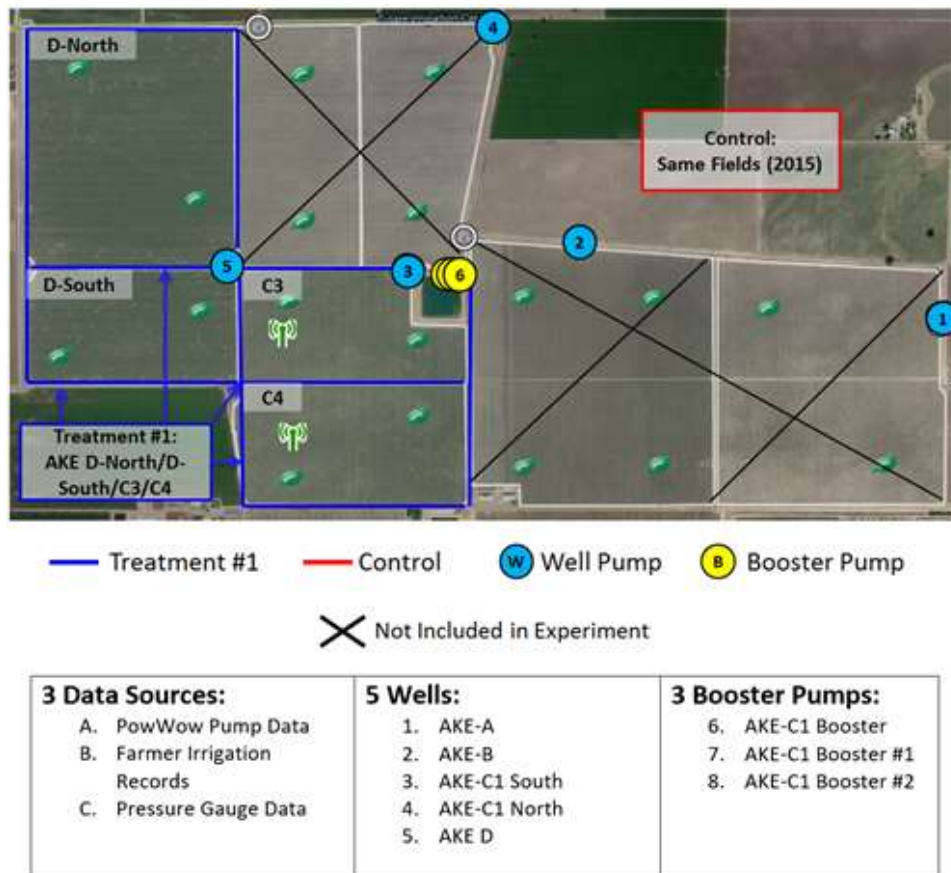

Source: University of California, Santa Barbara

6.1.2.1 Improvement of Pumping Plant Efficiency

The project team identified multiple issues in the way the pumps were used. First, the review of historical data showed that all three booster pumps were used on multiple occasions in 2014 even though only 1 or 2 boosters should be used at the same time to match the load of the different fields. The farm manager talked to the foreman and he stopped. Second, the team reviewed the energy use of the four wells (one well was later added in 2016) and found that one of them was used significantly less. The farm manager explained that there was a hole in the casing at AKE-A, and it affected the efficiency of the pumping plant. AKE-A had an OPE of 53% while the other wells had an OPE between 61% and 71%.

The farm decided to not use the AKE-A well in 2015. The farm manager also informed the team that the pump that was used the most (AKE-B) had to be pulled out in August 2014. “We want the pump alerts”, he stated after seeing that it can be tracked from the smart meter data. The project team recommended sharing the load on the three wells. As a precaution, the farm

drilled a new well in 2015, and it became operational in 2016. The pump test reported an OPE of 64%.

The project team also compared the amount of water pumped from the wells against the amount of water pumped by the boosters. The split is summarized in Figure 85. This was done to check the accuracy of the water measurement (it was the same within 5%) and also to gain insight on how the water and energy were being used. The project team performed calculations to understand the split of water among backflush (2%), irrigation (91%), evaporation at the reservoir (1%), and some deep percolation at the bottom of the reservoir (6%).

Figure 85: Description of the Experiment at the Almond Fields Near Tulare

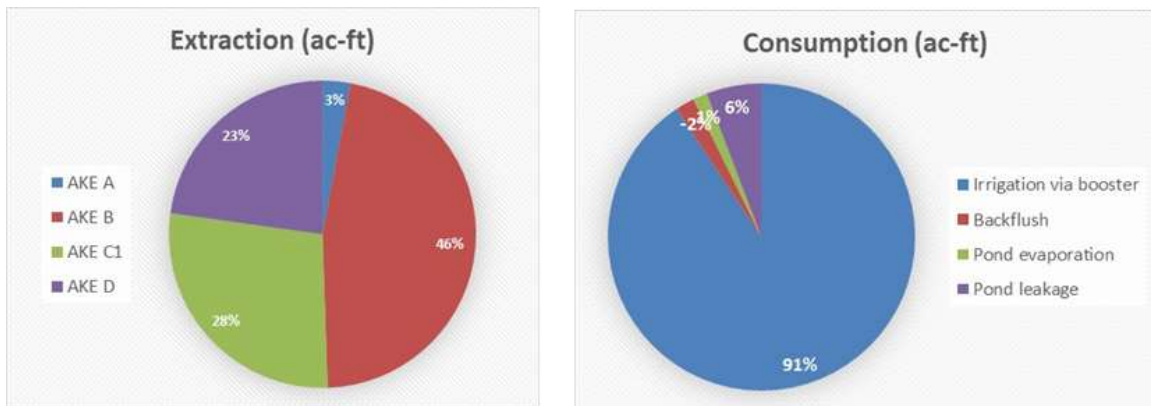

Source: PowWow Energy

6.1.2.2 Improvement of Water Use Efficiency

The diagnostic of the fields was difficult for the farm as there were multiple things going on at the same time. The project team used the methodology listed in Chapter 3 and started by comparing ET values with the application records. Most fields were not irrigated according to ET. However, the irrigator was not following a systematic deficit irrigation schedule either. The farm manager explained that they were primarily using a pressure chamber to measure water stress weekly.

Not starting irrigation scheduling with ET turned out to be the first issue. An example is plotted for AKE-D (Figure 86). The fields were under-irrigated early in the season and over-irrigated close to harvest. This led to a number of disease issues, which strongly complicated the operation of the ranch. *Altenaria* is one example. Another example at AKE-D is *Ceratocystis* canker infection after the trees are shaken for harvest. If a lesion occurs and there is higher ambient humidity, the wound can lead to the death of the trees.

Figure 86: Comparison of Applied Water with ET and DI Schedules for 2014 at field AKE-D

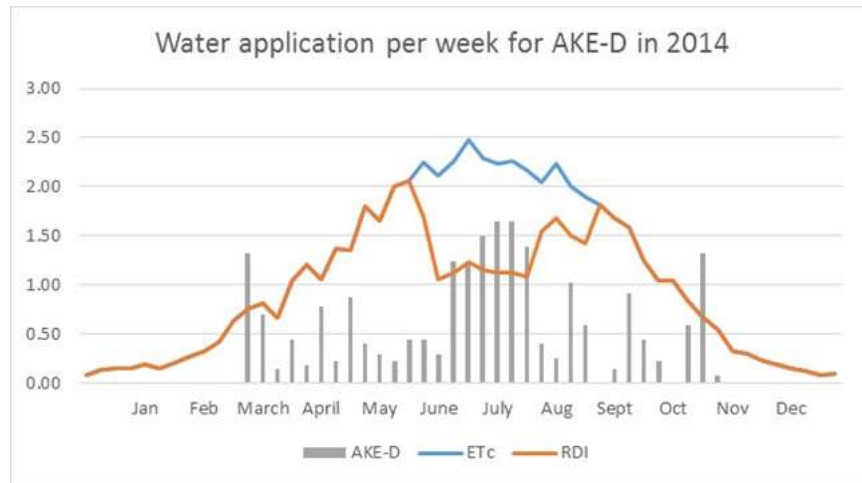

Source: PowWow Energy

In a second step, the project team checked the sources of variability and the farm verified the distribution uniformity of the irrigation system. This was done by leveraging aerial images (PWE) and field inspection (farm). The historical images showed a lack of uniformity and a degradation of the field in July; this was especially true for AKE-D (Figure 87).

Figure 87: NDVI Image of AKE-D in July 2014

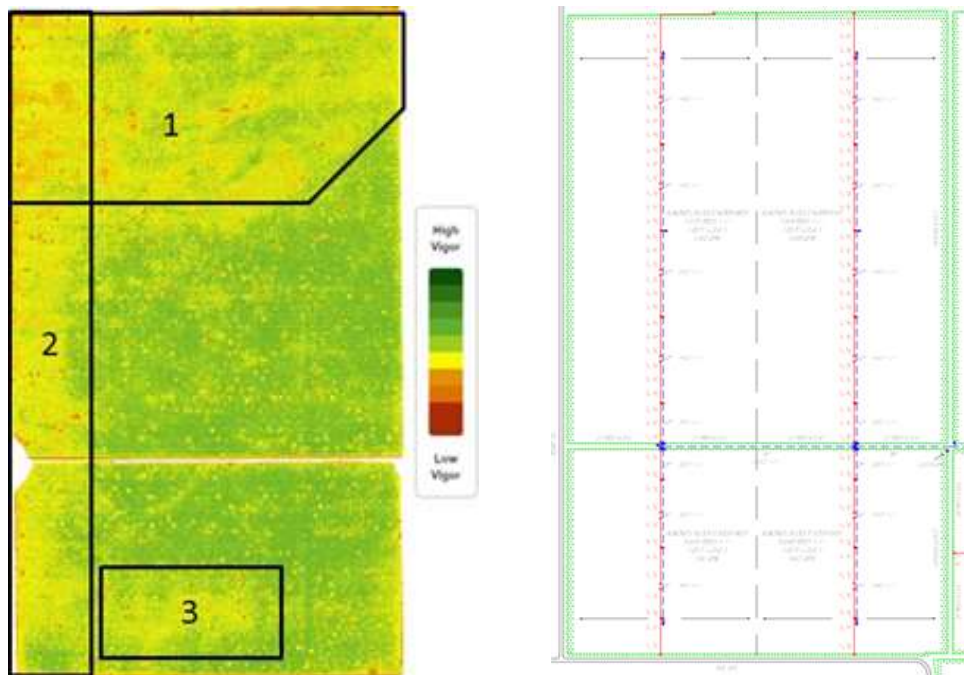

Three primary identifiable zones (left). The irrigation system has two irrigation sets with west and east blocks consisting of tens of sub-laterals controlled by manual valves (right).

Source: PowWow Energy

The project team checked the USGS-NRCS soil records and the farm manager checked the soil samples, and it was determined that the soil at the northwest corner was lighter (more sand in

area 1 shown in Figure 87). However, the band of stress continued down to the bottom of the fields (area 2). It may have been due to a malfunctioning valve or degradation in pressure. The irrigation system was fine according to the farm manager who inspected the field in spring 2015. However, he remembered that they applied flood irrigation during the winter to compensate for the lack of water. In that situation, the water floods from east to west. That led to a “double whammy”: less water reached the west side of the field (Figure 88), and less water was retained in the lighter soil area. As the field became stressed in the summer of 2014, the trees at the top west corner were attacked by spider mites in the summer.

Figure 88: Infiltration of Water During a Flood Irrigation Event

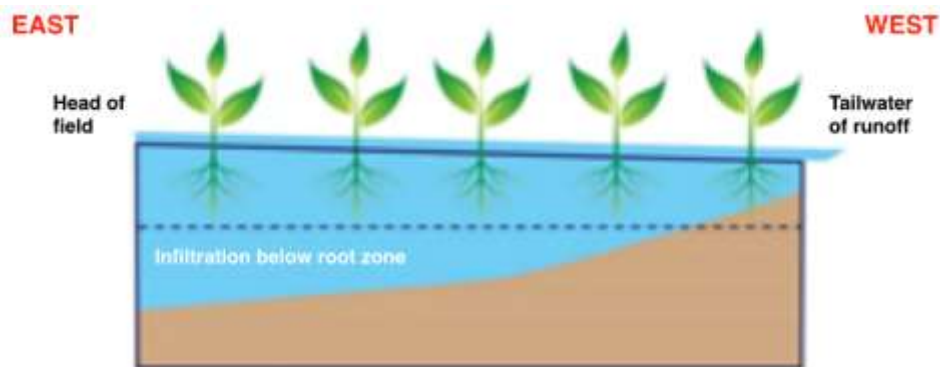

Flood irrigation starts at the head of the field (east for AKE-D) and the runoff water is minimized at the tail end (west for AKE-D). This leads to a difference in water infiltration from east to west in this case.

Source: PowWow Energy

The last issue (area 3) was diagnosed by the farm manager to be a salt build-up in the southern part of the field. He explained that they apply gypsum every year to improve water filtration but that it was done across the entire field. Having access to a shape file of the stressed area could lead to savings but the farm did not have a vehicle with a variable rate applicator. The vehicle is designed to apply the same amount and adjusts if the vehicle accelerates or slows down.

After the diagnostic was completed, the farm manager and the project team decided to implement an irrigation schedule based on ET to help the field recover strength, and to implement deficit irrigation again in 2016 using the decision support tool. During the 2015 season, the project team compared the applied water with the ET schedule. It was not perfect but the correlation was significantly higher and there was no stress during the nut filling period in May and June, which is a sensitive growth phase.

During the 2016 season the farm implemented a hull-split DI schedule, and the water application records are plotted against ET and DI levels in Figure 89. One can note that the deficit was implemented more gradually than recommended in the table in Chapter 3. This was due to the fact that the orchard consists of several cultivars that mature at different times. Rows of trees are harvested at different times during the summer and it is not possible to implement fully deficit irrigation on one cultivar (*e.g.*, nonpareil) without hurting another (*e.g.*, Fritz).

Figure 89: Deficit Irrigation Implemented Correctly at the Almond Orchard AKE-D in 2016

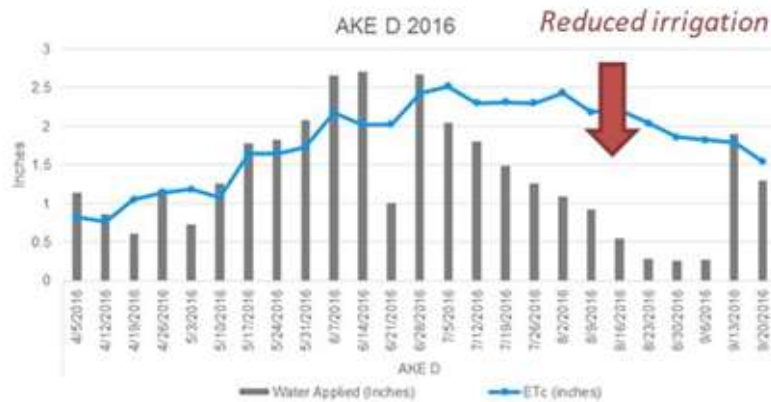

Source: PowWow Energy

The project team also decided to improve the uniformity of the field by compensating for the flood event early in 2015. The farming crew irrigated the west side of the field a little more each week during April and May. This led to a significant improvement in 2015, and the improvement continued in 2016 by avoiding flood irrigation all together in 2016 (Figure 90).

Figure 90: Evolution of Vegetation Uniformity Across 2014, 2015, and 2016 Seasons

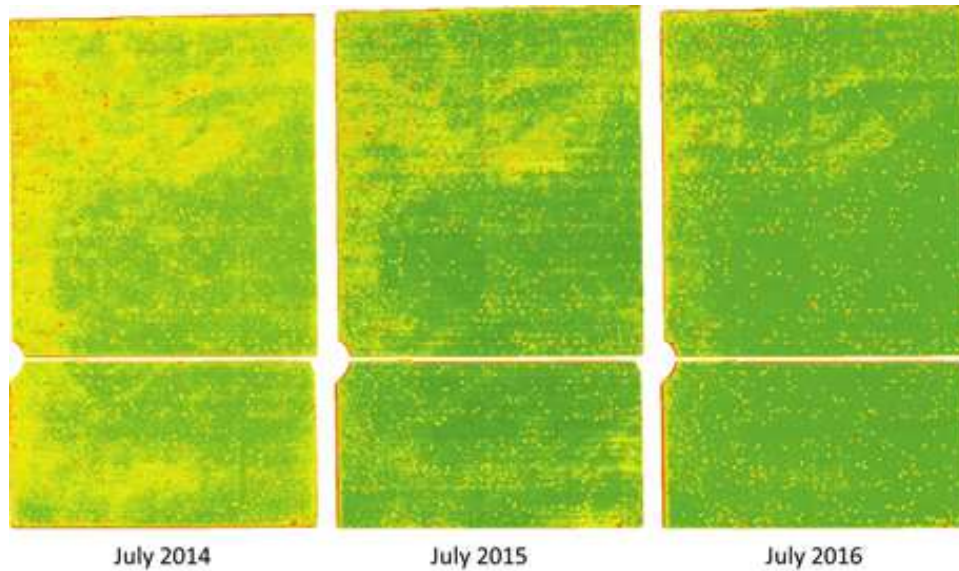

The difference between west and east bloks is mitigated with the change in irrigation practice during 2015. The trees continue regenerate in the north west corner with an increase in canopy.

Source: PowWow Energy

The in-depth analysis of AKE-D is provided as an example. Similar analysis was performed on AKE C3/C4. ET scheduling was followed in 2015 and 2016 for AKE C3/C4. The farm continued to perform measurements of SWP with a pressure chamber, but it was now a way to validate the implementation of the ET and partial ET scheduling as opposed to being used as a sole metric.

To make things easier for growers, the project team integrated the baseline calculation of SWP from UCD based on temperature and humidity. This allowed the team to create figures with simple bands of color that farms can use to drive irrigation. For almonds the team visualized:

- Partial ET schedule implemented at AKE-D with SWP values in the red band in June and July (8 to 12 bars below the baseline value, or roughly around -14 to -18 bars);
- Full ET schedule implemented at AKE-C3/C4 with SWP values in the yellow band during the months of June and July (4 to 8 bars below the baseline).

It is important to note that the selection of the trees is critical. Historical images can be used to pick areas that are representative of the field. The grower picked four locations for AKE-D. The response to stress will be different depending on several factors, including soil. In 2016, there was a noticeable difference in stress levels in the northwest and southwest corners (Figure 91, Figure 92). This is useful to verify that the stress is not too high for the weaker area of the field.

Figure 91: Evolution of SWP During 2016 Season for Tree in Lighter Soil Area of AKE-D Field

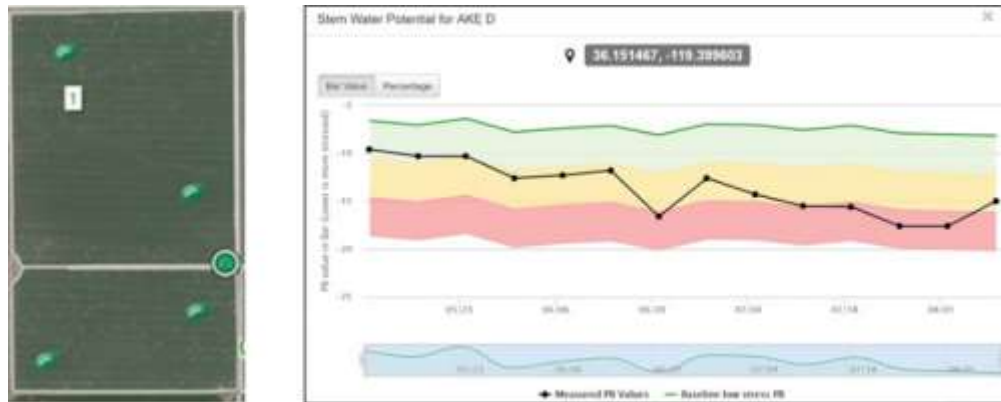

Source: PowWow Energy

Figure 92: Evolution of SWP During 2016 for Tree in Heavier Soil Area of AKE-D Field

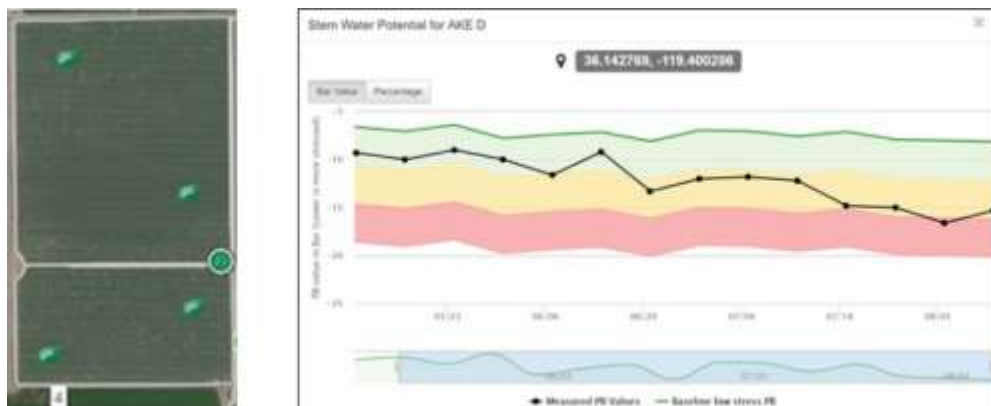

Source: PowWow Energy

6.1.3 Site #3 – Russell Ranch (Tomato)

The third site was a smaller demonstration site of 8 acres at Russell Ranch (Figure 93) operated by the Agricultural Sustainability Institute (ASI). The Russell Ranch sustainable agriculture facility is a unique 300-acre facility near the UCD campus dedicated to investigating irrigated and dry-land agriculture in a Mediterranean climate. Among Russell Ranch’s ongoing experiments is a 100-year study referred to as the Century Experiment, which is comprised of 72 one-acre plots. The staff at Russell Ranch and their collaborators measure the long-term impacts of crop rotation, farming systems (conventional, organic and mixed), and inputs of water, nitrogen, carbon and other elements on agricultural sustainability. Sustainability is indicated by long-term trends in yield, profitability, resource-use efficiency (*e.g.*, water or energy) and environmental impacts. For the project funded by EPIC, the project team focused on the opportunity to explore different levels of deficit and their impact on fruit quality and yield. The team also organized a field day in the summer of 2016. More information is provided in Chapter 8.

Figure 93: Description of the Russell Ranch Site

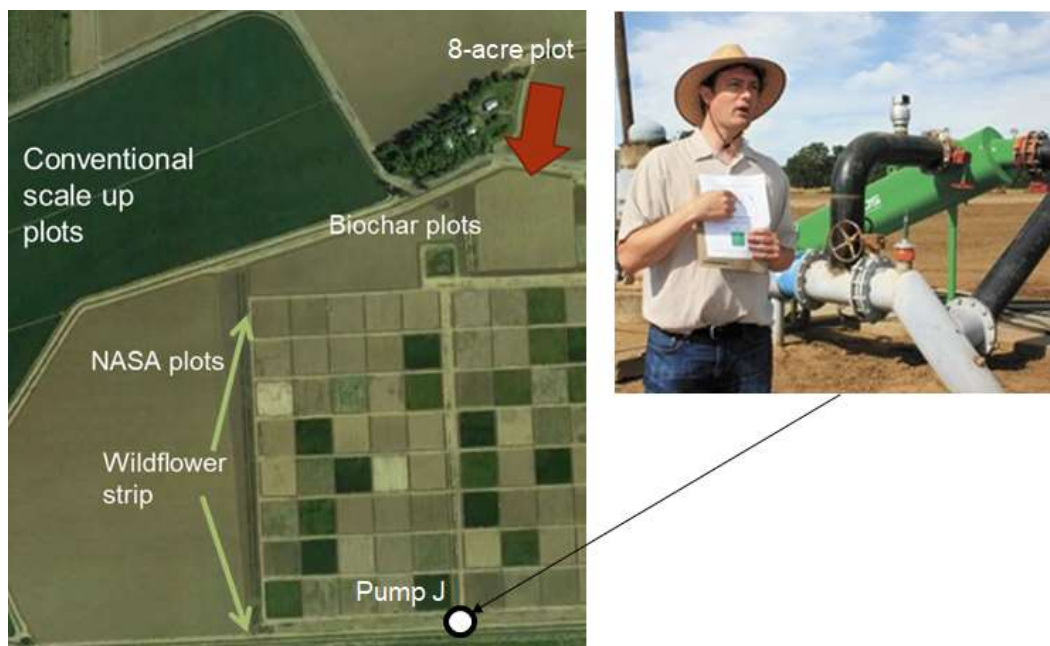

Sustainable agriculture facility (left) and the variable speed pump irrigating most of the experimental plots (right).

Source: University of California, Davis (left) and AgAlert™ (right)

6.1.3.1 Improvement of Pumping Plant Efficiency

Russell Ranch already invested in VFDs to improve the efficiency of the pumps across all the experimental fields. The project team leverage the VFD pump (Pump J in Figure 93) to improve the water measurement algorithm for variable speed pumps. For the energy intensity of the water at the 8-acre plot, the project team took the total use of energy divided by the total water use at the site. It was not part of the experiment to improve the energy efficiency of the 8-acre plot, as it did not have its own pumping system unlike a commercial field.

6.1.3.2 Improvement of Water Use Efficiency

The project team focused on measuring the impact of various levels of water deficit. The west side of the field was irrigated according to ET (treatment #1) and the east side was designed to have a deficit in irrigation according the strategy from UC ANR explained in Chapter 3. To make sure that variations in yield were not due to other factors, some random rows were selected to have an additional reduction in water using a pressure regulator (treatments #3 and #4). Both half-sections were configured with an ET station and a set of soil moisture sensors (Figure 94).

Figure 94: Description of the Deficit Irrigation Experiment at Russell Ranch

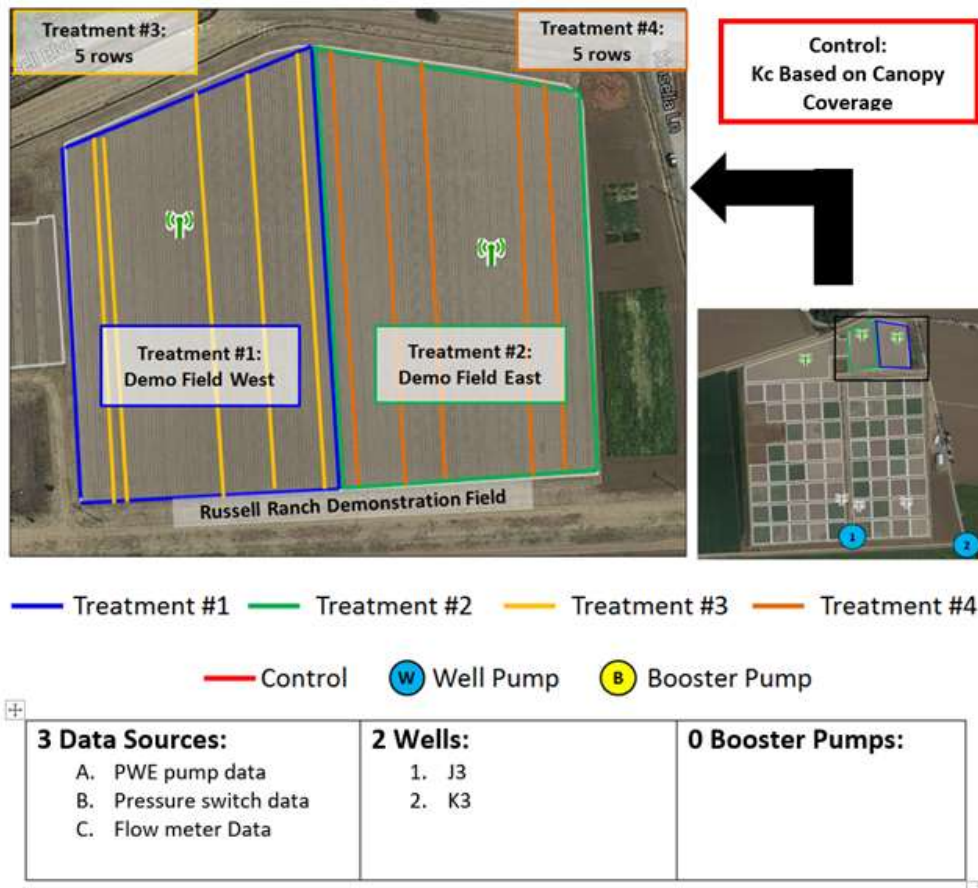

Source: University of California, Davis

The project team performed the experiment again in 2017 as the pressure regulators were found to be imprecise and Russell Ranch installed water flow meters for each of the treatments. The application of water over the season for each of the treatments is shown against the reference measured by the ET station (Figure 95). The team at UCD also measured the solid content in addition to the yield (including water; Table 14) to obtain a full picture of the crop from the point of view of the buyer (*e.g.*, cannery). Ideal late-season irrigation management is field-specific, but in most circumstances the crop can tolerate as little as 50% of ET_a as demonstrated by the work at site #3. In addition, the potential increase in in fruit soluble solids

concentration (SSC) has energy implications for the processor; it could provide additional savings since the fruit does not have to be dehydrated as much.

Figure 95: Comparison of Water Applied for the Four Treatments in 2017

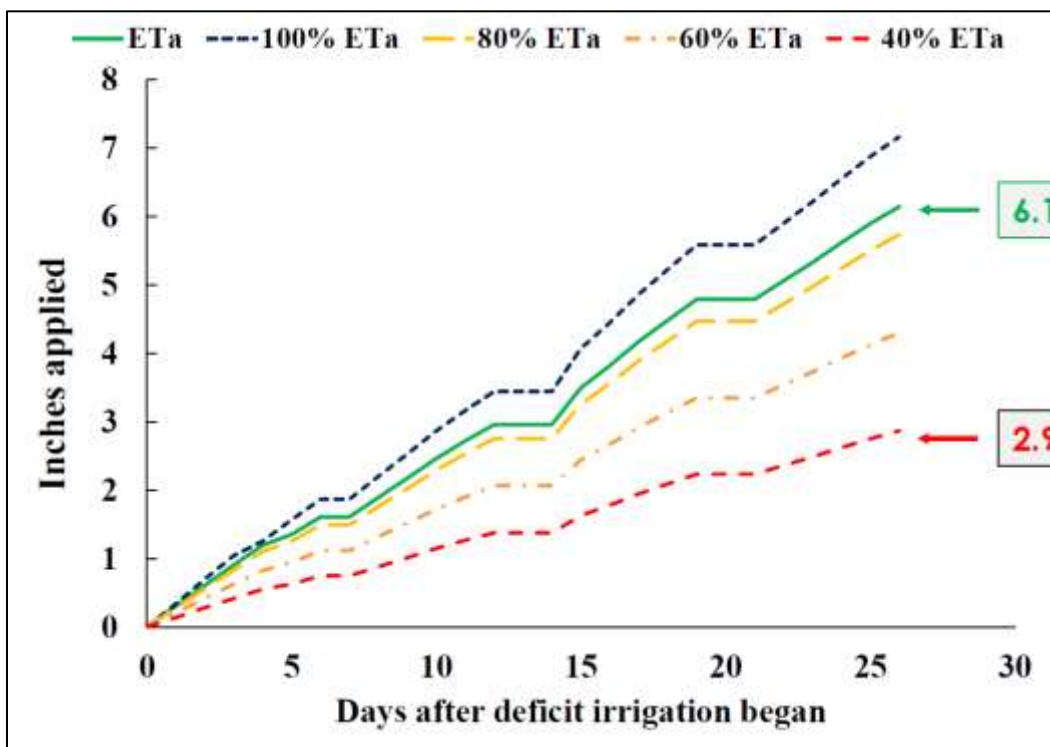

Source: University of California, Davis

Table 14: Summary of the Yield and Solid Content for all Treatments in 2017

Treatment	Applied water (inches)	Tomato fresh yield (tons/acre)	Brix	Brix yield (lbs/acre)
#1 (100% of ETa)	22.1	44.2	4.96	2864
#2 (80% of ETa)	20.7	39.6	5.08	2736
#3 (60% of ETa)	19.2	45.0	5.14	3123
#4 (40% of ETa)	17.8	42.6	5.06	2941

The amount of soluble solid content is measured by the metric Brix. One Brix represents 1 gram of sucrose in 100 grams of solution. Tomatoes for processing require a minimum Brix of 4.5.

Source: University of California, Davis

6.1.4 Site #4 – Meek & Sons (Tomato)

Meeks & Sons farm in the area near Davis and lease commercially a field that belongs to UCD. This field is operated independently by the grower, who is driven by the performance of the field (e.g., yield). The field called “UCD 56” has its own dedicated well (Figure 96).

Figure 96: Description of the Experiment at the Tomato Field Near Davis

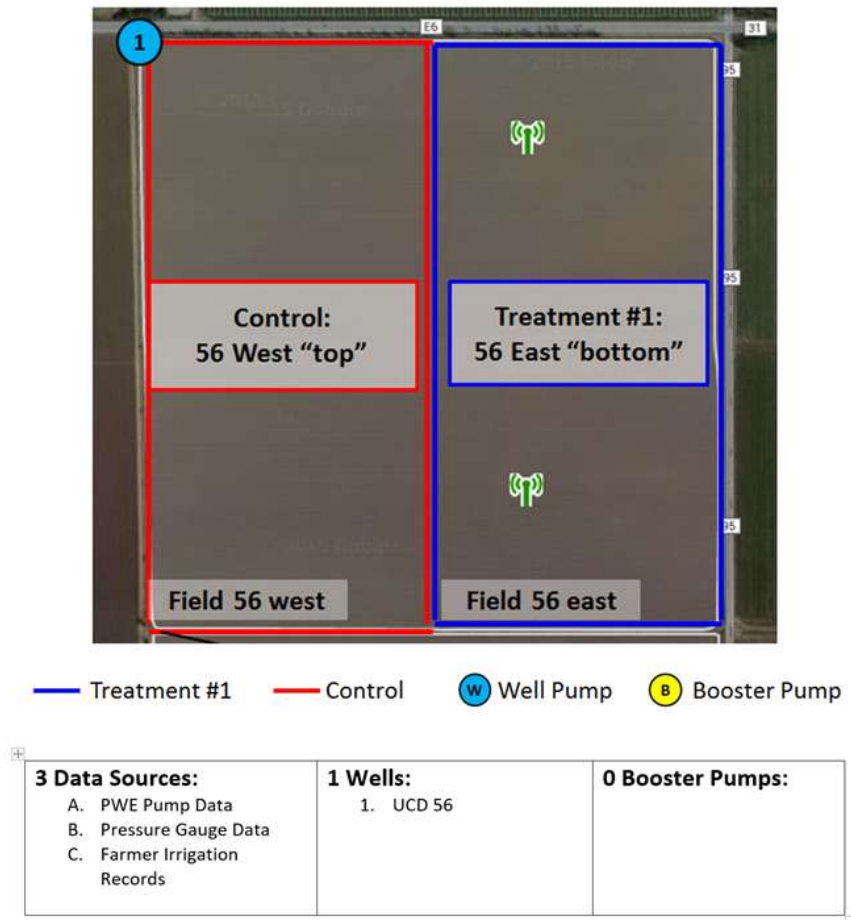

Source: University of California, Santa Barbara

6.1.4.1 Improvement of Pumping Plant Efficiency

The farm was interested in the pump alert capability because they had to pull out their pump in August 2014. They did not have water for two weeks and the neighbor had to pump water into a ditch to their field so they could irrigate and save their crop. When the team analyzed the smart meter data (Figure 97), the Pump Monitor captured the past anomalies due to a severe drop in water. This created a decrease in OPE, which could have been avoided most of the time. The alert would have come up two months before the pumps were damaged. Installing an extension would have been less costly than the full replacement of the bowls due to cavitation.

Figure 97: Smart Meter Data from the Well Pump at Site #4



The pump had to be pulled out and replaced in July 2014, whereas the pump was more stable in 2015.

Source: PowWow Energy

6.1.4.2 Improvement of Water Use Efficiency

When the project team interviewed the farm the first time, the team realized that the irrigation schedule was based on impressions (“soil is moist”) as if it was irrigated with furrows. However, the field was upgraded to a sub-drip-irrigation system that can more efficiently bring the water to the root zone of the tomato plants. The drip is buried 6 inches below the ground, so the soil is not as moist as it would be in the case of surface irrigation.

The project team compared the applied water against the ET schedule, and the farm was over 20% the amount of ETa most of the season (Figure 98). In this case, a change to simple ET scheduling would result in 20% water savings. The grower tried twice during the season to follow the ET schedule but he switched back quickly. He did cut off irrigation several weeks before harvest as growers traditionally do for tomatoes irrigated with furrows.

Figure 98: Comparison of Irrigation Records with ET Schedule for Tomato

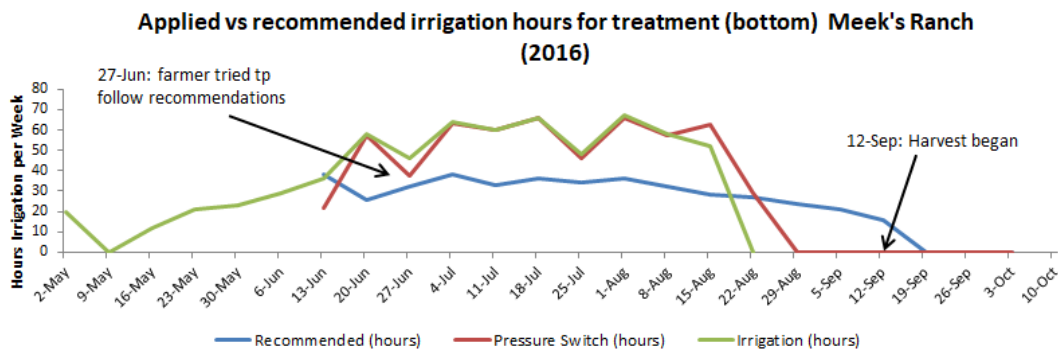

Source: University of California, Santa Barbara

6.1.5 Site #5 – Button & Turkovich (Alfalfa)

The project team looked at several fields at Button & Turkovich ranch. One field had SDI for a rotation of tomato and alfalfa. However, the efficiency of SDI was low for this type of soil because there were a lot of leaks due to gophers. The farm is forced to water heavily between cuts to avoid having wet areas when the machines come for harvest, similar to flood irrigation. It is easier for the farm to control rodents with flood. In Yolo County, there is also surface water allocation most of the years and irrigation uses less energy with flood techniques when canals are full.

6.1.5.1 Improvement of Pumping Plant Efficiency

During the drought, the water from the well is pumped into the ditch traditionally used for surface water, and then applied with siphons. This is a source of energy efficiency because a significant amount of water pumped percolates down into the soil. This is why the team decided to place a layflat directly connected to the output of the pump (Figure 99 right). It also has the advantage of precisely controlling the application (the amount of water coming out of siphons varies significantly with the level of water in the ditch).

Figure 99: Description of Alfalfa Field at Site #5 (Left); Flood Water Applied with a Layflat (Right)

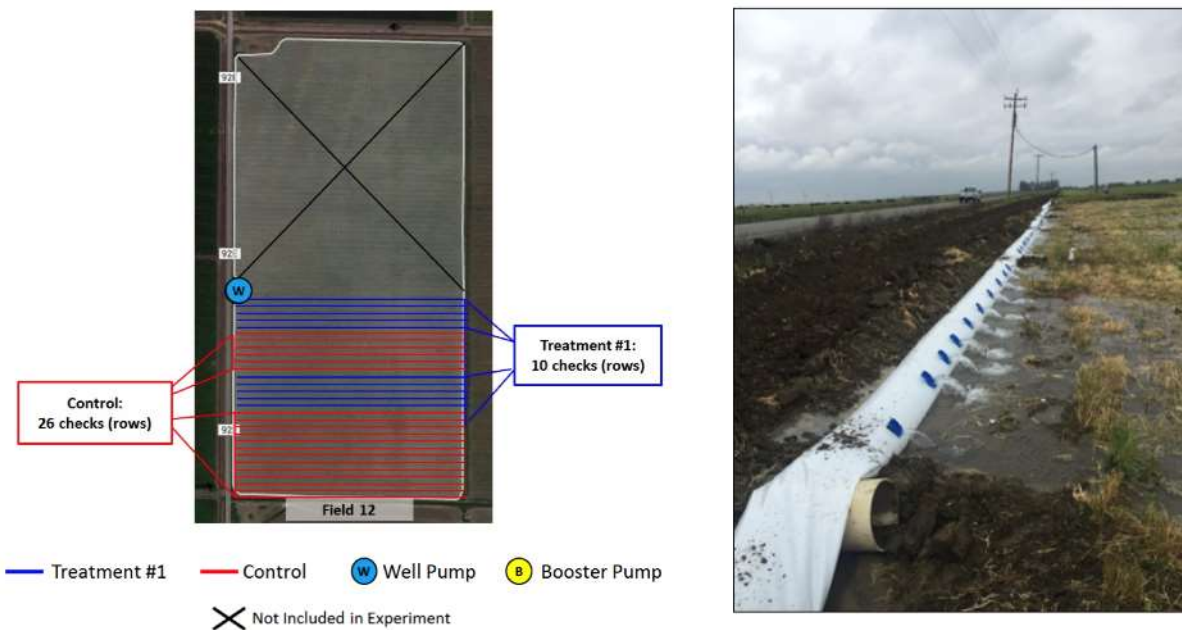

Source: University of California, Santa Barbara (left) and University of California, Davis (right)

6.1.5.2 Improvement of Water Use Efficiency

The project team decided to focus on optimizing flood irrigation control by timing the irrigation between cuts and turning the pump off using a thermal sensor installed in the middle of the field to avoid run-off. The project team had irrigation checks controlled by the project (blue) and some checks irrigated as usual by the foreman (red) to compare yield within the same year (Figure 99 left).

6.1.6 Site #6 Terranova Ranch (Multiple Crops)

The project team met the General Manager of Terranova Ranch Inc. (TRI) thanks to West Hills College in Coalinga. California Public Utility Commissioner Sandoval asked the founder of PWE to help with the organization of the first “hackathon” for agriculture. The project team participated in April 2015 and were introduced to Don Cameron, who was running a groundwater recharge experiment with the Natural Resource Conservation Service (NRCS). Storm water can be a liability along the Kings River, and TRI is allowed to open the gates to take the overflow and flood specific fields by leveraging its legacy flood irrigation system. The scale of the project was later increased from a field of wine grapes to the entire ranch of 2,600 acres thanks to a grant from the California Department of Water Resources (Figure 100). Construction started to cover an area of 16,000 acres in the basin.

Figure 100: Description of the Main Ranch at Terranova Ranch Inc. (TRI)



There are 22 well pumps, 3 lift pumps for groundwater recharge, and one solar array.

Source: PowWow Energy

In 2016, the project team used the site to test the accuracy of the water measurements based on smart meter data across many pumps and configurations. The team also developed a complete water record and compared it with the application records of the farm. It matched within 4%. Finally, the team experimented in tracking the smart meter data against the weather data. It was realized that the project could also identify issues in the performance of the solar array. The solar panels were not cleaned in the summer of 2016, which resulted in significant losses of energy (over 120 MWh). In addition to responding to the pump alerts, the general manager decided to have the panels clean mid-summer. This resulted in significant reduction in energy load and carbon emissions. The energy use was reduced by 23% while the amount of water applied was about the same (within 2%), thus resulting in 21% in energy savings. Most of the savings came from the cleaning of the panels (Figure 101).

Figure 101: Difference in Solar Energy Generation Between 2016 and 2017



Source: PowWow Energy

The solar output dropped during the summer of 2016 before coming back up with the first rain in the fall. In comparison a dust cleaning in mid-summer 2017 mitigated most of the energy lost the prior year.

Six fields were used in 2017 for the groundwater recharge project. Two of the long-term telemetry units used for Task 2 measured the groundwater level. The data showed that the groundwater level increased by 9 feet from November 2016 to November 2017 (Figure 102). It is important to take a reference measurement in the off-season (late fall or early winter) to get a stable reading. Maintaining the data collection was difficult. In one case, the cable was stolen. In another case, it was broken and had to repair it. This explains the gaps in the data shown in Figure 102.

Figure 102: Measurement of Groundwater Table in 2016 and 2017 at Pump 19 at Site #6

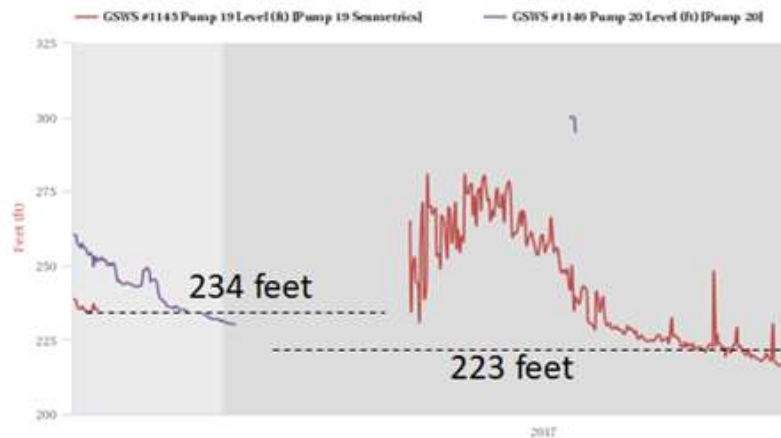

Source: PowWow Energy

6.2 Collection of Data and Baselineing

Data were collected for each deployment field in 2015, 2016, and 2017. The project team also obtained data for the orchards in 2014 using farm records for yield and smart meter data.

6.2.1 Collection of Water, Wnergy, and Yield Data

6.2.1.1 Water

Everything starts with water, but water is difficult to measure, as the team found out. One of the lessons learned is that it is important to have two sources of data to get a complete picture of what is going on and have some redundancy in case of communication or equipment failure.

First, the team secured weather data from two sources: National Weather Service (NWS) and DTN The Progressive Farmer (DTN). The team checked the accuracy of the data service by installing a station at site #6 as reported in Chapter 4.

Second, the team compared water records at the farm with the pump data from the smart meters. It is fairly easy to get an estimate of applied water (the number of hours that the pump is on to irrigate a field multiplied by the design rate of application), but there are a lot of variations across irrigation sets (different loads) and across the season (variation in water table). The team also found a lot of discrepancies in manual records. Daily data records contain a many entry errors because there are often last-minute changes, as field activities on any given day can get in the way of irrigation. But farmers try to stay on schedule on a weekly basis, so weekly schedules are relatively well maintained. The project team studied three sites in detail (site #2, #4 and #5) and found that it is critical to have at least two sources of water data:

- Supply: smart meters with PWE algorithm, or properly installed flow meters
- Demand: application records from the foreman, or a pressure switch at the field

The team compared the data for site #4, and the results were enlightening. The pressure switch data and the manual records show correlation overall, but there is a lot variation day-to-day. Also, the sensor was not available early in the season. Growers needs to have confidence in the reliability of the data to be comfortable with moving to a different and automated method of record keeping.

The team then compared the results to the pump data (Table 15). They were the same within +/- 2.3% as reported. The energy records are reliable because they meters are maintained by the utility and attached to a frequent financial transaction (monthly billing).

Table 15: Comparison of Different Methods of Measuring Water at Site #4 During 2016 Season

	Manual records (farm)	Pressure switch data (sensor)	Pump data (PWE)	Average
Water applied (ac-ft)	356 (<i>incomplete</i>)	392	374	383
Variation from average		+2.3%	-2.3%	

Source: University of California, Santa Barbara

UCSB used a similar method to measure water at each site. For site #4 (tomato), 30.5 inches was applied in 2016 with a level of confidence of +/- 2.3%. In addition, it rained 3.1 inches.

6.2.1.2 Energy

Collecting energy data was the easiest part of the data collection process. The team used the smart meter data to have access to measurements at 15-minute increments. However, the team had to coordinate with the IOUs to have a few meters upgraded from legacy meters to smart meters. It is free for growers to request an upgrade, and it typically takes 3 to 6 weeks to complete. PG&E and SCE were scheduled to complete the upgrade of all meters in California by the end of 2017.

6.2.1.3 Yield

Collecting yield data was the most difficult part because yield depends not only on volume but also on quality criteria (Figure 103).

Figure 103: Tomato Harvest at Site #4 (Left) and Almond Drying After Shake at Site #2 (Right)



Source: University of California, Davis

The project team discussed measuring biomass (commercial weight and non-commercial weight) but decided to choose the commercial measurements following USDA quality requirements because it is the production unit (output of farm). It also integrates various quality factors that can be influenced by irrigation, including solid content or pest damage. Table 16 summarizes the yield measurement requirements.

Table 16: Review of Yield Measurement by Crop

Variable	Tomato	Alfalfa	Pistachio	Almond
Number of harvests per year	1	6-7	2	1
Standard yield of marketable product (tons/acre)	Total amount of red tomatoes (wet weight)	Total dry biomass (dry weight)	Total amount of edible nuts and shells (with moisture <12%)	Total amount of edible nuts

Source: University of California, Davis

6.2.2 Developing a Baseline Using Life Cycle Assessment

The LCA model provided a framework to deal with the two parts of irrigation (the pump that moves water and the plant that consumes water to produce a crop). However, the challenge remained to define a baseline to estimate savings from the intentional changes enabled by the decision-support tool. Below are two different points of view, and the project teams attempt to reconcile them.

6.2.2.1 Farm: Every Season is Different

It was learned from agronomists that there are many factors that can affect a crop. It is best to measure changes within a season by having a control field (or part of a field) and a treatment field (or part of field). In the case of perennial crops, some changes in one season (*e.g.*, deficit irrigation) could have impacts in the following seasons, so it is important to look at three successive seasons.

6.2.2.2 Utility: Historical Baseline

It was learned from talking to utilities that it is preferable to have at least two years of historical data to set a baseline. Weather is a major factor in energy use. It is especially the case for irrigation. The pumping energy intensity varies greatly with weather and is difficult to do a deployment with a 2-year baseline, and a 3-year study (total of 5 years).

6.2.2.3 Concept of Water Management Unit

What is common between the two points view is the discipline to measure actual change, and exclude the impact of external factors. One approach to account for all factors is to define a “water management unit”. It means that the farm must enter all the input (*e.g.*, pumps) and outputs (*e.g.*, fields) at the site, even if they are not part of the experiment.

This is fairly simple in some cases, with one pump irrigating one field. For example, the tomato field at site #4 was irrigated two seasons in a row with the same pump (Figure 104 – left). But it is more complicated in most cases. The source of water can change, and the type of crops can change. For example, the orchards at site #2 (Figure 104 – right) are irrigated by multiple water sources. The water can come from the canal or a well, or a mix of both via a central reservoir.

Figure 104: Examples of Water Management Units: Site #4 (Left) and Site #2 (Right)



The water management unit for site #4 is one field irrigated by one pump (left). The water management unit for site #2 (right) is more complicated with multiple fields totaling 832 acres. The ranch is irrigated from 3 booster pumps located near the reservoir at the center. The reservoir is fed by 4 deep well pumps and/or three lift pumps depending on the surface allocation.

Source: PowWow Energy

The project team also leveraged historical data to “go back in time”. One advantage of the approach described in Task 2 is to measure energy and water for previous seasons. For instance, the team was able to get pump data for 2014 for the experiments on the permanent crops at sites #1 and #2, or the year prior to the experiments for the annual crops at sites #4 and #5. An example is provided in

Figure 105 for one of the pumps at site #2. In general, the tool provided by PWE provides at least one year of historical weather data, pump data, and aerial images to identify pre-existing conditions before starting a season.

Figure 105: Energy Data at One of the Pumps at Site #2

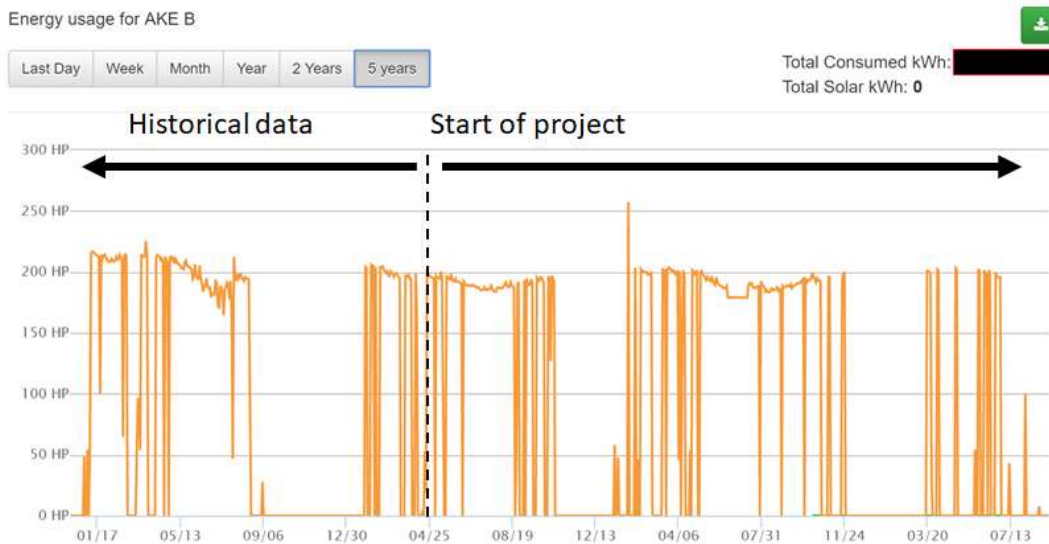

Data were collected from the smart meter after the start of the project, but historical data is available thanks to the Green Button API.

Source: PowWow Energy

6.2.3 Lessons Learned from the Deployment Experiments

The deployment sites illustrated several factors that influence the adoption of new irrigation practices. Human factors are mentioned in Chapter 8. The focus here will be on natural factors. The first one that came out is that row crops tend to be over-irrigated because of their shallow root zone, whereas tree crops tend to be under-irrigated. That was confirmed by Dr. Zoldoske, the Director of the Center for Irrigation Technology (CIT) at CSU Fresno. Irrigation is also an integral part of fertility and disease control.

6.2.3.1 Issues with Row Crops

Soil variability played a significant factor in the deployment of optimized irrigation scheduling at site #4 and site #5. While the field was uniform at site #5, the field at site #4 had three different types of soil in a scattered pattern (Figure 106).

Figure 106: Variation on Vegetation Index (NDVI) at Site #4

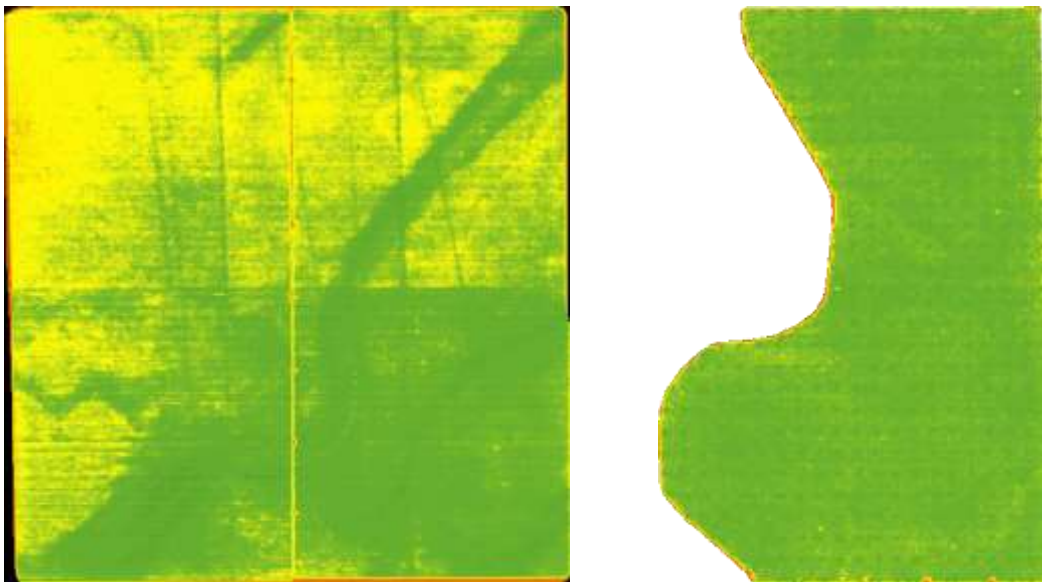

Variation across the tomato field (left) and across one of the pistachio fields at site #1 (right).

Source: PowWow Energy

6.2.3.2 Challenges with Permanent Crops

The time difference in maturation across the same field is a big challenge for tree crops. In the case of almond, where pollination occurs with interleaved rows of trees of different cultivars, it is very time-consuming to irrigate each row independently without automation of the valve control. The labor constraints mean that the farming crew can do only a few adjustments, such as turning off the set of valves one week before harvest of a cultivar (for instance, two rows out of six for nonpareil at AKE-D field) and turning them back on after harvest while the other cultivars are irrigated. It is not possible to do that for each week, and it is therefore impractical to have multiple irrigation schedules for each variety.

The case of pistachio is not as difficult because pollination is done with a male tree in the middle of 24 female trees. The pattern can be seen in the NDVI image of one of the field pistachio fields at site #1 (Figure 106 - right). The male trees tend to be bigger because they do not bear fruits. However, pistachio presents another challenge: the trees are characterized by alternate bearing when they become mature after the tenth season (called “leaf” in farming). The yield will fluctuate from 2,000-3,000 lbs per acre to 4,000-6,000 lbs per acre. While irrigation is similar from year to year, it is very difficult to make comparison in variations of yield in response to changes in irrigation schedules.

6.2.3.3 Tool to Help Achieve Sustainability of Groundwater Table

Probably the biggest lesson that was learned during the project is not to think about irrigation in a static way. Farms pointed out in 2017 that they had been using groundwater for several years and that they should use the surface water of a wet year to leach the soil. The farm at site #1 and site #2 did just that in 2017. In a way, the farm used more water.

However, the energy intensity that year for pumping was much less. The farm used the boosters primarily and the water from the district (gates or lift pumps). This cut the energy consumption by more than half. So it is not detrimental to the electricity grid to poor water in wet years. In Table 17, the team summarizes the energy intensity of pumping across all the sites. The intensity tends to increase from Sacramento Valley (north) to San Joaquin Valley (south). For site #1, the intensity was below 0.25 MWh/Ac-Ft during 2017 because only the booster pumps were used. In contrast, it was above 0.6 during drought years with the well pumps on.

Table 17: Energy Intensity of Pumping at the Study Sites in 2015 and 2017

Variable	Site #1	Site #2	Site #3	Site #4	Site #5
Booster Energy Use (MWh)	169,962	459,833	No Booster	No Booster	No Booster
Booster Water Pumped (Ac-Ft)	942	2657	No Booster	No Booster	No Booster
Booster Energy Intensity (MWh/Ac-Ft)	0.18	0.17	No Booster	No Booster	No Booster
Well Energy Use (MWh)	456,502	998,440	168,495	177,467	11,122
Well Water Pumped (Ac-Ft)	1007	2291	401	451	91
Well Energy Intensity (MWh/Ac-Ft)	0.45	0.43	0.42	0.39	0.12
Total Pumping Energy Intensity in drought year (MWh/Ac-Ft)	0.63	0.60	0.42	0.39	0.12
Total Pumping Energy Intensity in very wet year (MWh/Ac-Ft)	0.18	0.17	0.42	0.39	0.12

Source: University of California, Santa Barbara

The grower at site #6 took this concept further by developing the concept of groundwater recharge at the farm. Thanks to a grant from USDA-NRCS, Don Cameron demonstrated that he was able to flood his vineyard with 10 feet of water without affecting yield. This has the benefit to help reduce the depth of the standing water table, and reduce the energy required to lift ground water. This illustrated the concept of saving water with deficit irrigation in drought years and applying more water with flooding in wet years.

CHAPTER 7:

Results From Measurement and Verification

7.1 Life Cycle Assessment Approach

A framework was developed by UCSB to calculate the water and energy savings from implementing different efficiency techniques at the farm test sites reviewed in Chapter 6. Two different classes of treatments were applied: (1) smart irrigation schedules based on plant evapotranspiration (ET) to improve the water use efficiency, and (2) PWE’s Pump Monitor™ product to improve the pump energy use efficiency. The efficiency gain from the smart irrigation strategies was measured by comparing half of a field receiving the ET schedule (treatment) to the other half of the field receiving the farmer’s existing irrigation practices (control). The change in pumping energy efficiency was measured by comparing the energy efficiency of a given pump in a baseline year without Pump Monitor™ to the treatment year with Pump Monitor™. For this project, the efficiency gains (output/input) will be presented as resource intensity (input/output). A more detailed description of each site is given in Chapter 6.

To compare baseline and treatment impacts, a ‘functional unit’ was defined that encompasses the service provided by the product system (Langham and Geyer, 2017).⁸⁵ In LCA, the functional unit is a quantified description of the function or utility provided by the system. In farming, the utility of the system is yield; therefore, a functional unit of yield was selected. Commercially, yield is defined differently for each crop in this analysis. UCSB reached out to farmers and experts at UCD and determined the functional unit for each crop in this study to be based on weight (Table 18). In traditional comparative LCA, the product systems that fulfill the functional unit are compared through various impact categories. For this study, the functional unit at each site was compared in terms of water use per functional unit (ac-ft/ton yield) and energy use per functional unit (MWh/ton yield).

Table 18: List of Different Functional Units Specific to Each Test Site

Site Number	Site Name	Functional Unit
Site #1	Nichols: Drummond	1 ton pistachio edible nuts + shells with <12% moisture
Site #2*	Nichols: AKE	1 ton pistachio edible nuts + shells with <12% moisture - or - tons edible almond nuts/tons hulls (dry wt.)
Site #3	Russell Ranch	1 ton red tomato (wet wt.)
Site #4	Meeks	1 ton red tomato (wet wt.)
Site #5	Button & Turkovich	1 ton total dry alfalfa biomass (dry wt.)

*Site #2 contains parcels with almond and pistachios -- each crop will utilize individual functional units. Functional units selected based 2015 Yield Measurement Workshop involving UCD, UCSB and PWE.

Source: Langham and Geyer (Appendix B)

⁸⁵ Langham, K. and Geyer, R. (UCSB), 2017. *Life Cycle Protocol for Optimized Irrigation Scheduling*. California Energy Commission. Appendix B to CEC publication.

Water and energy footprints were compared between the baseline and the treatment irrigation strategies to test PowWow’s hypothesized 20% water and energy savings. Results should not be used to compare with other agriculture sites outside of this project, as many factors differ.

7.1.1 Water Use Intensity

The change in water use intensity was calculated by comparing the water use (ac-ft) per functional unit (ton yield) between treatment and control fields. Yield was gathered for each site in the format outlined in SubTask 7.5 Yield Measurement Requirements, and was reported separately for control and treatment fields. Total water use of the field was calculated by aggregating the water applied to the crop from three potential sources, groundwater irrigation, surface water irrigation and rain.

Given the drought pattern in the last five years, the majority of the farms in this project irrigated their crops primarily from groundwater, which was pumped from wells to the surface. Groundwater irrigation to crops was gathered from a selection of four data sources: PWE smart meters, Tule pressure switches, flow meters and farmer irrigation records. The presence of each data source for groundwater usage at each of the five sites was outlined in Table 19. Only Site #2 has the potential to use surface water, which was monitored through PWE smart meter and farmer irrigation records.

Table 19: Data Sources Available at Each Site to Estimate Total Volume of Water Applied to Each of the Fields Within the Study

Site	Water Data Sources
Site #1	<ol style="list-style-type: none"> 1. Smart Meter + PWE 2. Irrigation Records 3. Tule Pressure Switch
Site #2 Pistachio	<ol style="list-style-type: none"> 1. Smart Meter + PWE 2. Irrigation Records
Site #2 Almonds	<ol style="list-style-type: none"> 1. Smart Meter + PWE 2. Irrigation Records
Site #3	<ol style="list-style-type: none"> 1. Smart Meter + PWE 2. Small and Large Flow Meters
Site #4	<ol style="list-style-type: none"> 1. Smart Meter + PWE 2. Irrigation Records 3. Tule Pressure Switch
Site #5	<ol style="list-style-type: none"> 1. Smart Meter + PWE 2. Small Flow Meters

Source: Langham and Geyer (Appendix B)

Water was also applied to the crops naturally through precipitation. Typically, only a portion of the rain that falls makes it to the root zone of the plant for absorption; this is known as effective precipitation. The rest of the rain percolates below the root zone or evaporates off the

surface of the plant or ground. However, when the soil is dry, and the rain events are not heavy, the total precipitation and effective precipitation are approximately equal. UCD advised that for this project, given the drought and goal of simplicity, all precipitation should be considered “effective precipitation”. Therefore, total rainfall (as estimated through DTN or The National Weather Service) was added to irrigation quantity to calculate the total amount of water applied to crops. For tree crops (Sites 1 and 2) precipitation was aggregated for 1 year prior to harvest. For row crops (Sites 3, 4, and 5) precipitation was aggregated during the growing season (plant to harvest) and the soil moisture at transplant was added to this value to estimate the total precipitation to the crop.

7.1.2 Energy Use Intensity

To develop a methodology for calculating the energy intensity of farms, ‘energy intensity’ must first be carefully defined. On a farm, energy is consumed to pump water to fields, where the crops consume the water and produce yield; i.e. the input to the farm system is energy and the output is yield. Therefore, energy intensity of a farm is defined as the energy consumption (MWh) per ton yield (the functional unit). To calculate this definition of energy intensity on the farm, one must take the product of the pumping energy intensity and the irrigation water intensity (Figure 107).

Figure 107: Relationship Between the Two Components of Farm Energy Intensity

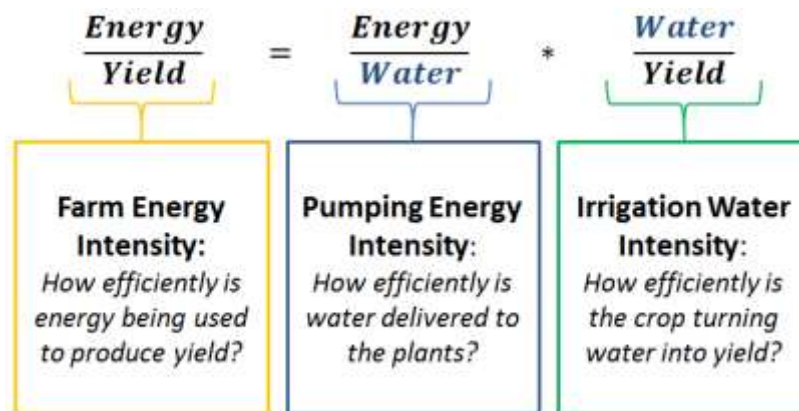

The input to the farm is energy, and the output is yield, and water is the factor that connected both flows.

Source: Langham and Geyer (Appendix B)

Pumping energy intensity is a measure of how much energy is required to pump water to the crop. Pumping infrastructure can be very simple (e.g., Site #3, where 1 ground water well pumps water to a single field) or complex (e.g. Site #2, where 4 groundwater wells and 3 surface water pumps deliver water into a reservoir and 3 booster pumps deliver water to 7 fields). Farms such as Site #2 with additional water pumping equipment will have a comparatively higher energy intensity.

Irrigation water intensity is a measure of how much water is required to produce a ton of yield; or rather, how efficient a plant is at converting water into yield. Therefore, the energy intensity

on a farm is the product of the pumping energy intensity and the irrigation water intensity. The energy intensity on a farm can be estimated on any scale (ranch or field) with these two variables.

7.1.2.1 Energy Intensity of Smart Irrigation

To calculate the reduction in energy intensity from treatment irrigation, the energy intensity for treatment and control fields was calculated using the equation in Figure 108. Thus, to estimate energy intensity for each field, the irrigation water intensity and the pumping energy intensity was first calculated.

Figure 108: Calculation of Field Energy Intensity

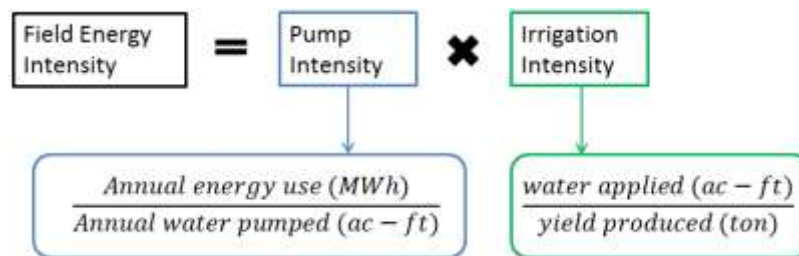

Source: Langham and Geyer (Appendix B)

To calculate the Irrigation Intensity variable, the same equation was used that was outlined in section 7.1.2 (total water applied/yield produced (ton)). To estimate Pumping (energy) Intensity, the total water pumped (ac-ft) and energy consumed (MWh) by the pump/boosters in a calendar year was aggregated and the ratio MWh/ac-ft was used as the value for pumping energy intensity. For sites where wells feed reservoirs and boosters feed the crops, the energy intensity of each appliance was calculated separately and aggregated to estimate overall energy intensity of the water application infrastructure. Once field energy has been calculated, the treatment fields will be compared with the control fields within the same year.

7.1.2.2 Measuring the Energy Intensity of the Pump

The application of Pump Monitor as a treatment to pumps results in a reduction of energy intensity through behavioral change; the data provided by the product influences a change in irrigation behavior. Precise behavioral changes can manifest in a number of ways (changes in this project were documented in Chapter 6) and will differ on a case-by-case basis. Measuring the impact of behavioral change is difficult. To measure the level of impact from this program, the total water pumped (ac-ft) per unit of energy consumed (MWh) was compared on an annual basis. Sites 1 and 2 compared values from 2015 and 2014, and Sites 4 and 5 compared values from 2016 and 2015. Site 3 did not have the Pump Monitor treatment applied. The selection of treatment and control years were based on which years would give the highest quality of data.⁸⁶ The quantity of energy consumed will be measured from smart meters on the pump, and the total water applied will be calculated by the PWE algorithm.

⁸⁶ *Ibid.*

7.1.3 Normalization of External Factors

In order to determine if the improvements in water and energy intensity were due to treatments, all factors that could significantly affect the three variables (yield, energy and water use) need to be either proven to be equal between control and treatment, or normalized for.

7.1.3.1 Normalization of Farm Energy Intensity and Irrigation Water Intensity

UCSB reached out to the ranch managers at each site and experts from UC Davis to come up with a list of all factors that could potentially significantly affect energy, water or yield (Table 20). Additionally, each crop was analyzed for crop-specific external factors (Table 21).

Table 20: List of Factors That May Cause Yield Energy or Water Use to Vary

Energy/Water Factors	Yield Factors
Temperature	Soil Fertility
Rainfall	Soil Type
Surface Water Allocation	Root Stock
Other Field Irrigation	Crop Variety
Pump Issues	Evapotranspiration (ET)
Overall Pump Efficiency	Weather Events
Distribution Uniformity	Pests
Soil Variability	Disease
Water Table Level	Crop Age
	Fertilization
	Irrigation Water Quality
	Timeliness of Harvest

Source: Langham and Geyer (Appendix B)

Table 21: List of Crop-specific Factors that Could Cause Significant Variation in Yield

Tomato	Alfalfa	Almond/Pistachio
Wind > 20 mph when Budding	Number Cuts	Winter Chilling
Excessive Heat During Fruit Set	Rain After Cut	Alternate Bearing
Soil pH (5-7 preferred)	Early/Late rain	Canopy Light Interception
Historical Crop Rotation	Insects	
Soil Salinity	Weeds	
Weed Presence	Year of Crop	

Source: Langham and Geyer (2017)

Normalization for all factors would was not possible with the resources provided in the project. However, an analysis of the potential influence of each factor on the experiment result was

completed to provide context. Each external factor will be labeled as “same”, “probably same”, “different” or “unknown”.

7.1.3.2 Normalization of Pump Energy Intensity

Unlike the biological system of a farm, the mechanical system of a pump is subject to influence from fewer external factors. Three external factors were identified to have a potential effect on pumping energy intensity. These three factors are, (1) surface water allocation, (2) water table depth, and (3) presence of other irrigation equipment. These three external factors will also be labeled using the same system previously described.

7.2 Results From the Deployments

The water and energy use intensity of each site were calculated using the methodology outlined in Section 7.1 (Table 22). Details of these calculations are reviewed in the subsections below. Irrigation schedules achieved up to 9% reduction in energy and water use intensity at Site #2 A, 3, and 5. Sites #1, 2P, and 4 had data issues or experimental errors preventing robust results. The pumping energy intensity decreased up to 24% at Sites #1, 2, and 5; Sites #3 and 4 did not have robust data.

Table 22: Overall Results in Energy and Water Use Intensity from Treatments

Site	Irrigation Water Use Intensity Change (%)	Irrigation Energy Intensity Change (%)	Pump Energy Intensity (%)
Site #1	X	X	-4%
Site #2 P	X	X	-1%
Site #2 A	-8%	-8%	-1%
Site #3	-9%	-9%	X
Site #4	X	X	X
Site #5	-9%	-9%	-24%

In cases where there were multiple treatments, the maximum savings is presented (Site #3). Cells with an X indicate that there were experimental issues preventing accurate data from being gathered.

Source: Langham and Geyer (Appendix B)

7.2.1 Water Intensity Results

The water use intensity (WUI) results for control and treatment fields in 2016 are summarized in Table 23. The percentage savings from smart irrigation schedules in the water use intensity is down in the far-right column. These were calculated by summing the total water applied (groundwater, surface water, and rainfall) and dividing it by the total yield (ton) from the experimental plots. Contextualization for the results of each site is covered in the sections below the table.

7.2.1.1 Site #1 and Site #2 (Pistachio)

The results at Site #1 and 2 are misrepresented due to the effect on an external factor: alternate bearing. Pistachio trees have ‘on’ and ‘off’ years, during which they produce large differences in

yield. Control and treatment fields were planted in different years, and thus were on different alternate bearing schedules. At Site #1, the treatment fields were in an ‘on-year’ in 2016 meaning they produced more yield than the control field, which was in an ‘off-year’. At Site #2 the treatment fields were in an ‘off-year’, meaning they produced much less yield relative to the control yield which was in an ‘on-year’.

Table 23: Results for Water Use Intensity at all Sites in 2016

Site	Treatment	Water Use Intensity (% change from control)
Site #1	Control	Control
	Treatment #1	-44.74%
	Treatment #2	-58.83%
Site #2 P	Control	Control
	Treatment #1	160.14%
	Treatment #2	53.39%
Site #2 A	Treatment #1	Considered control
	Treatment #2	-7.69%
Site #3	Treatment #1	3.73%
	Treatment #2	Control
	Treatment #3	-9.28%
	Treatment #4	-4.79%
Site #4	Control	X
	Treatment #1	X
Site #5	Control	Control
	Treatment #1	-9.25%

Sites #1 and Site #2 were subject to strong influence from alternate bearing between treatment and control fields, significantly skewing the results. Site #2 P represents pistachio fields and Site #2 A represents almond fields.

Source: Langham and Geyer (Appendix B)

7.2.1.2 Site #2 (Almonds)

The WUI results from the almond fields at Site #2 were fairly robust. These results show that the deficit irrigation reduced WUI by 7.69%. This suggests that further reduction in irrigation from ET may be beneficial for almond field efficiency.

7.2.1.3 Site #3

Similar to Site #2 almonds, there was no traditional control or farmer preference field at Site #3. Instead, treatment sections with various levels of deficit irrigation were compared to a

section receiving a full ET irrigation treatment. The section with the most deficit irrigation had the greatest reduction in WUI (9.28%) when compared with the full ET treatment. This suggests that additional reduction of irrigation under ET for the last few weeks before harvest may be beneficial for tomato water efficiency.

7.2.1.4 Site #4

There were two issues with the experiment at Site #4 in 2016 that prevented results from being generated. The farmer at Site #4 did not follow recommended irrigation quantities for the season and mid-season experimental design changes prevented some data from being gathered from the control side of the field.

7.2.1.5 Site #5

WUI was reduced on treatment checks at Site #5 by nearly 10%. This was due to a combination of reducing water applied to treatment checks and gathering higher yield on treatment checks. UCD colleagues working on this experiment advised that the variation in yield was likely random and not a result of irrigation variance.

7.2.1.6 Additional Data from 2017

Sites #2 and #3 gathered some additional data in 2017. At Site #3, the water use intensity of tomatoes were re-tested, due to some deviations from experimental design in 2016/15. In 2017, tomatoes were irrigated with 100% ET irrigation schedule (based on in field Tule sensor). Six weeks before harvest, the field was divided into 4 equal sections, and delivered varying levels of deficit irrigation from 100% ET_a to 40% ET_a. The results from this experiment are presented in Table 24. Interestingly, the section with the greatest deficit had the greatest reduction of water use intensity of 16%. These results corroborate previous research claiming that deficit implemented about six weeks before harvest allows for water reduction without negatively impacting yield.

Table 24: Results from 2017 Experiments at Site #3 (Russell Ranch)

Treatment	Yield (ton/acre)	Water applied (in)	WUI (ac-ft/ton)	Change from Control (%)
100% ET _a	44.2	22.1	0.0416	Control
80% ET _a	39.6	20.7	0.0434	4%
60% ET _a	45.0	19.2	0.0356	-14%
40% ET _a	42.6	17.8	0.0348	-16%

The experiment and data collection was led by UCD. Note: only the precipitation that fell during the growing season was included.

Source: University of California, Davis

At Site #2, both almond fields received an irrigation schedule based on 100% estimated ET_a. Data was gathered in 2017 to ensure that the tree yield did not suffer from irrigation strategies applied in 2015/16. Yield at AKE-D fields had a 0% change while yield at AKE-C3/C4 only decreased by 4%. These changes are not large enough to be considered meaningful.

7.2.2 Energy Intensity Results

The energy intensity was reduced through the pumping system (pumping energy intensity) and from irrigation treatments (reduction of water pumped).

7.2.2.1 Pumping Energy Intensity

The percent change in pump energy intensity from pump monitor for each site has been calculated in Table 25. The changes represent the change in pumping energy intensity (MWh/ac-ft) from the distinguished baseline year.

Table 25: Changes in Pumping energy Intensity (MWh/ac-ft) for Each Project Site

Site	Change in Pump Energy Intensity (%)
Site #1	-1%
Site #2	-4%
Site #3	X
Site #4	X
Site #5	-24%

Source: Langham and Geyer (Appendix B)

Sites 1 and 2 compared values of pump energy intensity from 2015 and 2014, while Site #5 compared values of pump energy intensity from 2016 and 2015. The PWE Pump Monitor treatment was not applied to the pump at Site #3, therefore no results are presented for that site. There were no reliable data available for total water pumped in 2015 at Site #4, thus an annual comparison of energy intensity was not possible. Results for Sites #1, 2, and 5 had significant inaccuracies using the planned methodology. In an attempt to calculate results closer to the truth, an alternative methodology was developed and applied at each site, and was used to generate the results in Table 24. It should be noted that reductions in energy intensity from this project resulted from behavioral changes (documented in Chapter 6) in addition to influence from external factors (documented in Sub Chapter 7.2.3), which will vary on a case-by-case basis. A detailed description of the alternate methodology and primary data accuracy analysis are provided in Langham and Geyer (2017).⁸⁷

7.2.2.2 Field Energy Intensity

The energy intensity for each field has been calculated as the product of the irrigation water intensity and the ranch level pumping energy intensity (Table 26). Irrigation water intensity was previously calculated using the methodology described in section 7.1.2, and the results were presented in section 7.2.1. The pumping energy intensity was calculated using methodology described in section 7.1.3, and the results were presented in section 7.2.2.1.

⁸⁷ Langham and Geyer, 2017. *op. cit.*

Table 26: Percentage Change of Field Energy Intensity Relative to the Control Field at Each Site

Site	Treatment	Energy Intensity (% change from control)
Site #1	Control	Control
	Treatment #1	-45%
	Treatment #2	-59%
Site #2 P	Control	Control
	Treatment #1	160%
	Treatment #2	53%
Site #2 A	Control	X
	Treatment #1	Considered control (ET)
	Treatment #2	-8%
Site #3	Treatment #1	4%
	Treatment #2	Considered control (ET)
	Treatment #3	-9%
	Treatment #4	-5%
Site #4	Control	X
	Treatment #1	
Site #5	Control	Control

Pumping energy intensity was estimated at a ranch level and held constant for each field in order to isolate the impact of the irrigation strategy. Site #4 experienced an experimental issue preventing comparison between treatment and control.

Source: Langham and Geyer (Appendix B)

There was a large range of relative impacts on the field energy intensity of the treatment fields from irrigation strategy, which mirror the impact of water use intensity presented in Table 23. As with the water use intensity results, the relative impacts on energy intensity at Sites 1 and 2 are misleading from the influence of alternate bearing. Almond fields showed a reduction of 8%, tomatoes showed a reduction of up to 9% on the greatest deficit irrigation, and the alfalfa showed a reduction of 9% on field energy intensity. These results suggest that smart irrigation strategies offer a method to reduce water use on the ranch without compromising yield.

7.2.3 Normalization Considerations

The farmers at each site, PWE employees, and agronomic experts were interviewed to discuss all factors that might influence the results in this experiment.

7.2.3.1 Normalization of Farm Energy Intensity and Irrigation Water Intensity

The best estimates of the likelihood that each external factor had an effect on project results are presented in Table 27 and Table 28. ‘Same’ means factors were definitely the same between control and treatment; ‘probably same’ means that factors were highly likely the same, but the project team does not have evidence to be certain; ‘different’ means the team has evidence to prove that the factor differed between control and treatment; ‘unknown’ means the team was not able to determine if factors were the same between control and treatment and ‘X’ means that the factor does not apply to the specific site. An in-depth discussion of the effects of each external factor on the results for every site is provided in Langham and Geyer (2017).⁸⁸

Table 27: Matrix of External Factors That May Have Affected Yield or Energy/Water Use at Site #1 and Site #2 During the Experiment

Energy/Water Use Factors (Sites #1 and #2)				
Meta	Factor	Site #1	Site #2 (P)	Site #2 (A)
General	Temperature	Same	Same	Same
	Rainfall	Same	Same	Same
	Surface Water Allocation	Same	Same	Same
	Other Field Irrigation	Same	Same	Same
	Source of Water	Different - Managed	Same	Same
	Overall Pump Efficiency	Different - Managed	Probably Same	Probably Same
	Distribution Uniformity	Same - Managed	Same - Managed	Same - Managed
	Soil Variability	Different	Different	Different
Yield Factors (Sites #1 and #2)				
Meta	Factor	Site #1	Site #2 (P)	Site #2 (A)
General	Soil Fertility	Unknown	Unknown	Different
	Soil Type	Different	Different	Different
	Root Stock	Same	Unknown	Probably Same
	Crop Variety	Same	Different	Same
	Evapotranspiration (ET)	Different	Unknown	Unknown
	Weather Events	Same	Same	Same
	Pests	Same	Different	Same
	Disease	Same	Same	Same

⁸⁸ *Ibid.*

	Crop Age	Different	Different	Different
	Fertilization	Different	Different	Different
	Irrigation Water Quality	Same	Same	Same
	Timeliness of Harvest	Same	Same	Same
Alfalfa Specific	Number Cuts	X	X	X
	Rain After Cut	X	X	X
	Early/Late Rain	X	X	X
	Insects	X	X	X
	Weeds	X	X	X
	Year of Crop	X	X	X
Tomato Specific	Wind > 20 mph when Budding	X	X	X
	Excessive Heat During Fruit Set	X	X	X
	Soil pH (5-7 preferred)?	X	X	X
	Historical Crop Rotation?	X	X	X
	Soil Salinity	X	X	X
	Weed Presence?	X	X	X
Pistachio/Almond	Winter Chilling	Same	Same	Same
	Alternate Bearing	Different	Different	Unknown
	Canopy Light Interception	X	X	Unknown

Source: Langham and Geyer (2017)

Table 28: Matrix of External Factors That May Have Affected Yield or Energy/Water Use at Site #3, Site #4, and Site #5 During the Experiment

Energy/Water Use Factors (Sites #3, #4, and #5)				
Meta	Factor	Site #3 (Tomato)	Site #4 (Tomato)	Site #5 (Alfalfa)
General	Temperature	Same	Same	Same
	Rainfall	Same	Same	Same
	Surface Water Allocation	Same	Same	Same
	Other Field Irrigation	Same	Same	Same
	Source of Water	Same	Same	Same
	Overall Pump Efficiency	Same	Same	Same
	Distribution Uniformity	Same - Managed	Same - Managed	Same - Managed

	Soil Variability	Probably Same	Different	Unknown
Yield Factors (Sites #3, #4 and #5)				
Meta	Factor	Site #3 (Tomato)	Site #4 (Tomato)	Site #5 (Alfalfa)
General	Soil Fertility	Same	Same	Probably Same
	Soil Type	Probably Same	Different	Unknown
	Root Stock	Same	Same	Same
	Crop Variety	Same	Same	Same
	Evapotranspiration (ET)	Probably Same	Probably Same	Same
	Weather Events	Same	Same	Same
	Pests	Same	Same	Same
	Disease	Same	Same	Same
	Crop Age	Same	Same	Same
	Fertilization	Same	Same	Same
	Irrigation Water Quality	Same	Same	Same
Timeliness of Harvest	Same	Same	Same	
Alfalfa Specific	Number Cuts	X	X	Same
	Rain After Cut	X	X	Same
	Early/Late Rain	X	X	Same
	Insects	X	X	Same
	Weeds	X	X	Same
	Year of crop	X	X	Same
Tomato Specific	Wind > 20 mph when Budding	Same	Same	X
	Excessive Heat During Fruit Set	Same	Same	X
	Soil pH (5-7 preferred)?	Probably Same	Probably Same	X
	Historical Crop Rotation?	Same	Same	X
	Soil Salinity	Probably Same	Probably Same	X
	Weed Presence?	Same	Same	X

Source: Langham and Geyer (2017)

7.2.3.2 Normalization of Pump Energy Intensity

The three variables that were identified to have a potential effect on pumping energy intensity in this study are outlined in Table 29. Surface water allocation was different at Sites 4 and 5, water table level was likely different at all sites, and use of extra pumping equipment was the same at every site for the years compared. An in-depth discussion of the effects of each external factor on the results for every site is provided in Langham and Geyer (2017).⁸⁹

Table 29: Matrix of Factors That May Have Had an Effect on Pumping Energy Intensity at the Project Sites

Site	Years compared	Surface water allocation	Water table depth	Additional pumping equipment
Site #1	2014 - 2015	Same	Probably Different	Same
Site #2	2014 - 2015	Same	Probably Different	Same
Site #3	n/a	Same	Probably Different	Same
Site #4	n/a	Different	Probably Different	Same
Site #5	2015 - 2016	Different	Probably Different	Same

Source: Langham and Geyer (Appendix B)

Water table depth was identified as the external factor that was likely different between control and treatment years at all sites. Typically pump tests would provide the necessary data to analyze water table change annually. However robust water table data was not available from pump tests, so an analysis was done for Sites #1, 2, and 5 using California Statewide Groundwater Management Program (CASGEM) public data.⁹⁰ Data was gathered from 3 to 5 CASGEM wells within four miles of the test sites, and the average water elevation level was calculated (Figure 109).

⁸⁹ *Ibid.*

⁹⁰ California Department of Water Resources. *CASGEM Online System*. www.casgem.water.ca.gov/OSS. Accessed 12 Feb. 2018.

Figure 109: Average Water Table Elevation at CASGEM Registered Wells Near Sites #1, #2, and #5

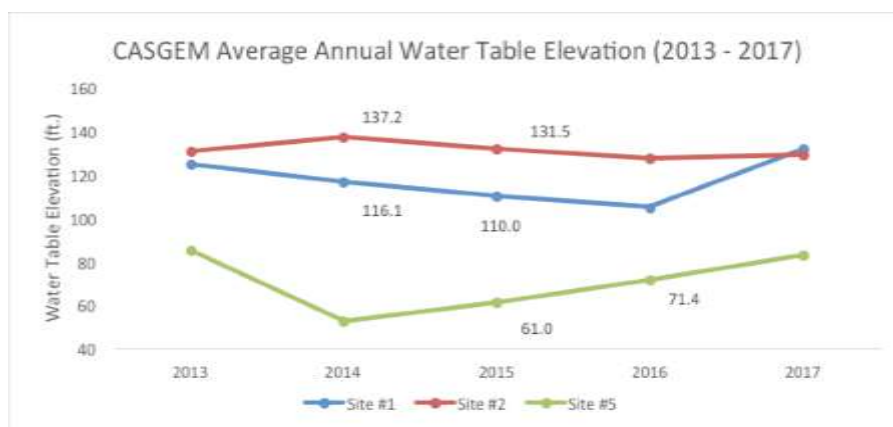

Years with data labels represent control and treatment years for the analysis of pumping energy intensity

Source: Langham and Geyer (Appendix B)

Between 2014 and 2015, the water table elevation at CASGEM wells around Sites #1 and #2 reduced by 6.1 ft and 5.7 ft, respectively. Reduction in water table level increases the energy intensity of the groundwater tells, resulting in reduced savings. Conversely, the water table elevation at Site #5 in the north increased by 10.4 ft. An increase in water table would reduce the energy intensity of the pump, which helps explain why savings at Site #5 were so high. Quantifying the impact from the change in water table elevation on the pumping energy intensity was outside the scope of this study.

7.3 Review of Benefits and Impact on California

This technology provides California growers with an affordable solution for improving water use efficiency and reducing energy consumption. The existing Pump Monitor product has proven to be highly cost effective because its deployment does not involve hardware costs. No new infrastructure to build beyond the smart power meters already being installed by California's IOUs (a recent workshop hosted by CPUC identified leak avoidance as the most cost-effective energy efficiency measure related to agricultural water use^{91,92}). The new Irrigation Advisor product is also highly cost effective for the same reason - *i.e.*, it is a software-based solution that does not require upfront capital investment apart from on-farm sensors that growers may already have. More importantly, growers can use benchmarks from historical images and select an irrigation strategy developed by the Cooperative Extension system. This technology can be used by IOUs to provide ratepayers with incentives to achieve further energy efficiency by providing a mechanism to reward ratepayers based on performance (energy actually saved) as opposed to savings calculated from engineering principles. During CPUC workshops, PG&E and other utilities have expressed that being able to bring in market energy

91 Sandoval, C., 2014. *California Water/Energy Efficiency Proceedings*. 19 Jun. 2014. www.cpuc.ca.gov/uploadedFiles/CPUC_Public_Website/Content/About_Us/Organization/Commissioners/Catherine_Sandoval/June_2014-Water_Energy_Nexus.pdf. Accessed 13 Feb. 2018.

92 California Department of Water Resources, 2009. *California Water Plan Update 2009*. http://www.waterplan.water.ca.gov/docs/cwpu2009/0310final/v2c02_agwtruse_cwp2009.pdf

management solutions like PWE’s under their energy efficiency programs would overcome a major barrier to increasing ratepayer participation in those programs.⁹³

To estimate the project benefits, the project team assumed that the impacted market segments consist of commercial production of the following four crops in California: almonds, pistachios, tomatoes, and alfalfa. The acreage planted in California for the crops of interest account for 30% of the 9.6 million acres of farmland in California; using average water application rates indicated by the farm advisors and extension agents the project team worked with on this project, these four crops accounted for approximately 34% of the 34 million acre-feet of water used annually for irrigation (Table 30).

Table 30: Cultivated Acreage (2016 Crop Year) and Average Water Application in California for the Four Crops Investigated During the Project

Crop	Area under cultivation (acres)⁹⁴	Average water application (acre-feet/acre)	Annual water use for irrigation (acre-feet)
Almond	1,202,093	3.7	4,447,744
Pistachio	329,826	2.8	923,513
Tomato (processing)	266,010	2.5	665,025
Alfalfa	1,105,698	5.1	5,639,060
Total	2,903,627		11,675,342
All CA farmland⁹⁵	9,600,000		34,000,000

Source: USDA⁹⁴; DWR⁹⁵

The energy intensity for agricultural water consumption (in kWh per acre-foot) varies widely in California, depending on the source of the water and the region where the farm is located. In a report published by the Energy Commission’s PIER program, values of 0 to 375 kWh/ac-ft were reported for the supply of agricultural surface water and values of 196 to 391 kWh/ac-ft were reported for the supply of agricultural groundwater (these values were only for the supply of water to the farm site and did not account for energy consumption by booster pumps at the site to deliver water to crops, pressurize drip irrigation lines, etc.).⁹⁶ For these calculations, the team chose an average value of 352 kWh/ac-ft for the total irrigation system (water supply and booster), which was the average of the values observed at the experimental sites during this

93 Sethuraman, S., 2014. *Communications – Water/Energy Workshop, CPUC, September 10, 2014. Presentation from Manager of Industrial, Agricultural & Water Programs at PG&E.* docs.cpuc.ca.gov/PublishedDocs/Efile/G000/M167/K737/167737883.PDF. Accessed 13 Feb. 2018.

94 United States Department of Agriculture. *County Ag Commissioners’ Data Listing: Crop Year 2016.* www.nass.usda.gov/Statistics_by_State/California/Publications/AgComm/Detail/. USDA’s National Agricultural Statistics Service California Field Office. Accessed 18 Feb. 2018.

95 California Department of Water Resources. *Agricultural Water Use Efficiency.* www.water.ca.gov/Programs/Water-Use-And-Efficiency/Agricultural-Water-Use-Efficiency. Accessed 15 Feb. 2018.

96 Navigant Consulting, Inc., 2006. *Refining Estimates of Water-Related Energy Use in California.* California Energy Commission, PIER Industrial/Agricultural/Water End Use Energy Efficiency Program. CEC- 500- 2006- 118, pg. 39.

project. Based on this average energy intensity value, the annual consumption of electricity associated with irrigation for the four crops examined in this study was 4110 GWh, which accounts for approximately 41% of the total amount of electricity consumed annually by agricultural water related use in California (10 TWh).⁹⁷

PowWow Energy projects that market penetration will reach 20% of the total acreage planted in almond, pistachio, tomato, and alfalfa in California, or 580,725 acres, in the next 10 years (Table 31). This corresponds to average deployment of approximately 50,000 acres per year, which is conservative when one considers that (1) PowWow Energy had 20,000 acres of trials for its *Pump Monitor* in 2014; and (2) sensor companies like PureSense achieved 300,000 acres of deployment in five years despite having to go door-to-door. Market penetration of sensors is favorable for adoption of this solution because it puts a burden on growers and farm advisors to analyze an increasing amount of data. The project address that burden by distilling large amounts of data into usable information. The key is to provide practical answers to simple problems in agriculture. By integrating cloud-based data and local data, PowWow can provide real answers that will allow the team to break into a larger market than just the early adopters who are more tech savvy. This project, including the collaboration with Russell Ranch and the Cooperative Extension system, is critical for the successful commercialization of this solution. There are dashboard solutions on the market (*e.g.*, OnFarm) that will compete with this solution indirectly. The project team thinks 20% market share is reasonable because of the differentiating features: integration with ET scheduling, dashboard for energy-efficiency and carbon-credits programs, and privacy management.

Table 31: Projected Market Penetration and Associated Water Savings, Energy Savings, and GHG Emission Reductions

Year	Deployment acreage	Annual water savings (ac-ft)	Annual energy savings (GWh)	GHG reductions (MT CO2e)	Energy cost reductions (\$)
1	58,073	12,253	6.65	1,882	700,837
2	116,145	24,507	13.3	3,764	1,401,674
3	174,218	36,760	19.9	5,645	2,102,511
4	232,290	49,013	26.6	7,527	2,803,347
5	290,363	61,267	33.2	9,409	3,504,184
6	348,435	73,520	39.9	11,291	4,205,021
7	406,508	85,773	46.5	13,172	4,905,858
8	464,580	98,026	53.2	15,054	5,606,695
9	522,653	110,280	59.8	16,936	6,307,532
10	580,725	122,533	66.5	18,818	7,008,368
Total	580,725	673,932	365.7	103,496	38,546,026

Source: PowWow Energy

⁹⁷ California Energy Commission. *Agriculture and Food Processing Research*. <http://www.energy.ca.gov/research/iaw/agriculture.html>. Accessed 17 Feb. 2013.

7.3.1 Water Savings

In the field trials performed during this project, the team observed an average reduction in water use of 0.211 ac-ft/acre resulting from use of the PWE decision support tools. The associated annual water savings calculated for the commercial application of the PWE technology to the cultivation of almond, pistachio, tomato, and alfalfa in California ranged from 12,253 ac-ft in Year 1 to 122,533 ac-ft in Year 10, for a total water savings of 673,932 ac-ft over a 10-year timeframe (Table 31).

7.3.2 Energy Savings

From the data obtained over the course of the project, the project team observed an average reduction in the energy intensity of irrigation of 114.5 kWh/acre resulting from the experimental treatments. This represented a combination of the effects of reduced water usage resulting from the changes in irrigation scheduling associated with the *Irrigation Advisor* (86.2 kWh/ac) and the effect of increased pumping system efficiency resulting from the use of the *Pump Monitor* (28.3 kWh/ac). The calculated annual energy savings ranged from 6.6 GWh in Year 1 to 66.5 GWh in Year 10, for a total energy savings of 365.7 GWh over a 10-year timeframe (Table 31). In addition, the reduction in electricity consumption will itself contribute to water savings because water is used during the generation of electricity at thermoelectric power plants (25 gal of water are used per kWh of electricity generated, primarily for cooling; an additional 2 gal are lost to evaporation, on average, while the rest is recovered⁹⁸). This is another illustration of the energy-water nexus and how saving energy by reducing the demand for irrigation water pumping has multiple benefits for California.

7.3.3 Reductions in GHG Emissions and Energy Costs

Reductions in energy costs and GHG emissions associated with commercial deployment of the PWE technology are calculated as \$ 0.1054 in cost savings (based on average statewide industrial rates) and a reduction of 0.000283 metric tons of CO₂ equivalents (MT CO₂e) per kWh of electricity saved, in accordance with the guidelines in *Attachment 14 (References for Calculating Energy End-Use, Electricity Demand, and GHG Emissions)* from the original proposal solicitation. Annual GHG emission reductions range from 1882 MT CO₂e in Year 1 to 18,818 MT CO₂e in Year 10, and annual energy cost reductions range from \$700,837 in Year 1 to \$7,008,368 in Year 10. Over a 10-year timeframe, the proposed technology will result in a reduction in GHG emissions of 103,496 MT CO₂e and reduction in energy costs of \$38,546,026 to California IOU ratepayers (Table 31).

98 U.S. Environmental Protection Agency. *Water-Energy Connection*. www.epa.gov/region9/waterinfrastructure/waterenergy.html. Accessed 12 Feb. 2018.

CHAPTER 8:

Workshops with Farms, Utilities and Agencies

The project team started the project at the height of the drought, and there were understandable tensions during that period among the various users of water: urban, agricultural, and environmental. Agriculture represents about 80% of the developed water in California, but it is important to note that it does not include environmental water. On an average year, environmental water represents 50% of total water use, while agricultural water represents 40% of water use and urban water represents 10% of water use. This varies significantly between wet years and dry years (Figure 110).

Figure 110: Water Use in California in Dry Years and Wet Years

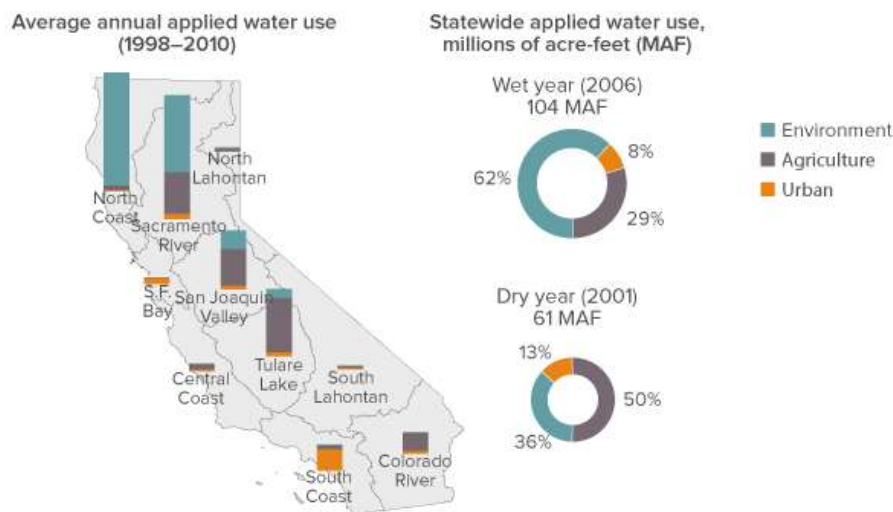

Statewide, average water use is roughly 50% environmental, 40% agricultural, and 10% urban, although the percentage of water use by sector varies dramatically across regions and between wet and dry years.

Source: Department of Water Resources

To address cultural gaps, the team decided to have a collaborative approach among the team members who came from different background: a technology start-up from Silicon Valley (PWE), a land-grant university with long-standing relationships with agricultural community (UCD), and a university with a leading environmental program (UCSB). In this chapter, the team summarizes this technology transfer activities to IOUs, the CDFA, and local agencies. In the spirit of collaboration, the team looked at opportunities to integrate this decision tool with existing programs to increase the impact of the decision tool and not “reinvent the wheel”. For instance, the Pump Monitor was selected to quantify the reduction of water consumption and greenhouse gas emissions for CDFA’s Statewide Water Efficiency and Enhancement Program (SWEEP).⁹⁹

⁹⁹ California Energy Commission. *EPIC Symposium Helps Create Agricultural Water and Energy Saving Partnership*. Jun. 27, 2017. calenergycommission.blogspot.com/2017/06/epic-symposium-helps-create.html. Accessed Feb. 18, 2018.

8.1 Technology Adoption by Farms

8.1.1 Diffusion Process: Difference in Technology Adoption

The ability to scale across many farms is critical to save significant amount of water and energy. The project team found that adoption is a major challenge in agriculture because of the long technology adoption cycle in this industry. For instance, while the first demonstrations of drip irrigation happened in the 1970s, its widespread adoption did not occur until the 1990s.

The technology adoption cycle is a well-known concept in the technology community (Figure 111). The gap between the “early adopters” and the “early majority” requires developing a “whole product” beyond a core technology. It demands focus on securing a first “beach entry” market from which the solution can grow to other market segments. In the case of Pump Monitor, this could be almond growers in San Joaquin Valley.

Figure 111: Technology Adoption Cycle

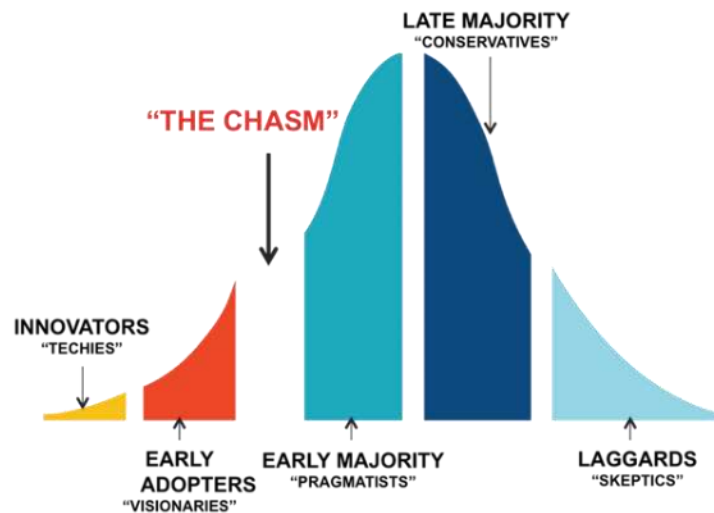

While deployments can be achieved by deployments with early adopters, it is necessary to address the practical concerns of the majority of farms. The growers at site #5 are an example of a “pragmatist” while the grower at site #4 is a good example of a “conservative”. The grower at site #2 is an “early adopter” who tried deficit irrigation without all the tools in place. The grower at site #6 is an “innovator” who implemented the first on-farm groundwater recharge in California with the support on NRCS and DWR.

Source: Department of Water Resources

This approach is not at odd with the market adoption of the farming community. By analyzing the irrigation practice of the sites compared to crop ET, the team realized that there was a similar pattern. While some of the deployment sites had already tried deficit irrigation (*e.g.*, site #2), other sites were not implementing irrigation based on ET (*e.g.*, site #4). Most of them used some form of ET data to help with irrigation and were trying to gather objective information before making a decision (*e.g.*, site #5). The project team invited growers to discuss their various approaches to irrigation at a panel at UCD and share their thoughts on technology (Figure 112). Regulations came up as a factor in technology adoption in the farming sector.

Figure 112: Grower Panel Led by CDFA Science Advisor Dr. Gunasekara During the Last Session



Source: University of California Davis

The team researched further and learned that the concept of “diffusion process”, which supports the “technology adoption cycle”, was actually developed by agricultural researchers in the 1950s. This is quite remarkable. The demographic and psychological profiles of each adoption group, which are commonly used in the technology industry for any sector, were originally specified by the North Central Rural Sociology Committee for the Study of the Diffusion of Farm Practices, by agricultural researchers Beal and Bohlen.¹⁰⁰ The categories from Beale’s study are:

- “Innovators”: larger farm owner who are more educated, prosperous and risk-oriented
- “Early adopters”: younger and more educated farm managers who tended to be community leaders, less prosperous;
- “Early majority”: more conservative farmers but open to new ideas, active in their community, and influential by sharing best practices with their neighbors;
- “Late majority”: older farmers who are fairly conservative and less socially active;
- “Laggards”: very conservative with small farms and limited access to capital.

8.1.2 Field Days: Role of the Cooperative Extension

The Cooperative Extension system is a non-formal educational program implemented in the United States designed to help people use research-based knowledge to improve their lives. The service is provided by the states’ designated land-grant universities. In most states, the educational offerings are in the areas of agriculture and food. The University of California Cooperative Extension (UC-CE) is the public service division of the University of California. It plays an important role in the adoption of new technologies to improve farming practices in California because it provides neutral, third-party testing and can carry out long-term studies, as it is the case with Russell Ranch (site #3). The project team organized a “field day” at Russell

¹⁰⁰ Bohlen, J.M. and Beal, G.M., 1957. *The Diffusion Process*. Special Report No. 18. Agriculture Extension Service, Iowa State College. 1: 56-77.

Ranch in Yolo County, and then organized two others in Ventura County in collaboration with SCE and in Fresno in collaboration with PG&E.

8.1.2.1 First Field Day: June 8, 2016 at Russell Ranch on UCD Campus

The field day started with on-site demonstrations at three different locations: a groundwater well pump, century experiment plots, and front fields. The demonstrations were followed by vendors' presentations and a poster session. The event ended with a panel of growers moderated by Amrith Gunasekara from the California Department of Food and Agriculture (CDFA) focusing on challenges and opportunities of on-farm water management.

PWE gave two presentations during the on-site demonstrations titled "Energy-water nexus in irrigation management" and "Water measurement from smart energy meters - pumps with variable frequency drivers". UCD gave two presentations; "Approaches for irrigation optimization of annual row and perennial crops" and "Deficit irrigation for processing tomatoes" (Figure 113).

Figure 113: Field Day on June 8, 2016 at Russell Ranch



Talk on water measurement from smart meters (left) and talk on rational irrigation scheduling (right).

Source: University of California Davis

This first field day was a real success and was well received by the agricultural community. The California Farm Bureau periodical "AgAlert" published an article on the field day (Figure 114).

Figure 114: Field Day at Russell Ranch and PWE Featured in AgAlert



Source: AgAlert™, publication of the California Farm Bureau

8.1.2.2 Second Field Day: July 19, 2016 at Hansen Ag Research & Extension Center

This event was hosted by the UC Hansen Ag Research & Extension Center in Santa Paula on July 19, 2016 (Figure 115). It was supported by UC-ANR, California Lutheran University, UC Santa Barbara, and CSU San Luis Obispo. This event aimed at building bridges between the Tech and Ag community in the tri-county area (San Luis Obispo, Santa Barbara, and Ventura).

Figure 115: Flyer for the Field Day at Hansen Ag Research & Extension Center Near Ventura

AG MEETS TECH:
Simple Solutions to Real Challenges in Water

Tuesday, July 19, 2016
8:30-1:30PM
Hansen Ag Center
14292 W Telegraph Rd,
Santa Paula

Agenda

- 8:00 Sign-in and Breakfast
- 8:30 Welcome by Dr. Christopher Smith, UCCE
- 8:45 Short Talks on Water Management
- 9:45 Field Demonstrations
- 11:00 Panel with Growers and Entrepreneurs
- 12:00 Networking Lunch
- 1:30 Adjourn

FREE ENTRY

UCSB University of California Agriculture and Natural Resources
California Lutheran UNIVERSITY
CAL POLY SAN LUIS OBISPO

Source: University of California, Santa Barbara

The half-day event started with an information session targeted to growers about simple solutions available today for managing water. It was scheduled at 8:30 am so growers could get their day started and join the event. The team also had field demonstrations for technologists who want to learn about local crops, irrigation, and soil. PWE presentations focused on the following topics: “Groundwater monitoring from smart meters” and “Automated water records” (Figure 116). The field day ended with a panel of local growers and entrepreneurs who are dealing with new challenges in agriculture and leveraging technology to address them. Jim Dunning from Cal Poly Technology Park moderated the panel focusing on new challenges in agriculture (Figure 117).

Figure 116: Field Demonstration: Talk on Automated Water Records



Source: PowWow Energy

The panel highlighted the following hurdles to adoption of new technologies to conserve water:

- Environment: salinity is becoming a problem due to drought and ocean water getting into aquifers
- Time horizon: tech innovation is fast and goes through trials and errors; decisions in agriculture have long-term consequences.
- Economic development: agriculture is a \$5 billion industry in the tri-county area; how can technology in water and the local market be leveraged to create new jobs?

Figure 117: Grower and Entrepreneur Panel Led by Jim Dunning From Cal Poly Technology Park



Source: PowWow Energy

8.1.2.3 Third Field Day: October 5, 2016 at Terranova Ranch

A third field day was scheduled on October 5, 2016 at Terranova Ranch (Figure 118). Terranova Ranch was established in 1979, in Helm, CA in the central San Joaquin Valley, and currently has 5,700 acres under cultivation. Since 1981, Don Cameron has worked as the general manager of the ranch, which has always focused on water conservation.

The field day focused on the following topics: groundwater management, optimized irrigation scheduling, unlocking adoption of energy and water savings in processing tomatoes, and data integration and privacy management to enable 21st century farming.

Figure 118: Third Field Day Near Fresno on October 26, 2016, With More Than 60 Growers

Field day: the latest in groundwater management



Agenda

- 8:00 am Sign-in and breakfast
- 8:30 am Welcome by Don Cameron, Terranova Ranch Inc.
Introduction by Olivier Jerphagnon, PowWow Energy.
- 8:45 am Field demonstrations: three aspects of groundwater management
- 10:30 am Short presentations: optimized irrigation scheduling. Moderated by Dr. Kate Scow, UC Davis and Russell Ranch.
- 11:45 am Networking lunch followed by panel discussions
- 12:30 pm Panel: unlocking adoption of energy savings solutions in processing tomatoes. Moderated by Virginia Lew, California Energy Commission.
- 1:30 pm Panel: data integration and privacy management for 21st century farm. Moderated by Dr. Chandra Krintz, UC Santa Barbara.
- 2:30 pm Adjourn

Wednesday, October 26, 2016
8:30-2:30PM
Terranova Ranch
16729 W. Floral Avenue, Helm



Free entry for growers – space limited



Please RSVP at <https://www.eventbrite.com/e/field-day-at-terranova-ranch-tickets-27546724996>

Source: PowWow Energy

PWE staff made one field demonstration while UCSB and UCD made one research talk each. One grower from the Energy Commission project shared his experience in a talk titled “Tool-kit to tune irrigation schedule: A grower’s perspective”. Terranova Ranch shared their experience with groundwater recharge (Figure 119).

Figure 119: Field Day at Terranova Ranch



Growers are welcome to the field day (left) and attend one of three hands-on demonstrations. Don Cameron (right) reviews the benefits of on-farm groundwater recharge.

Source: PowWow Energy

The field day ended with a lunchtime panel that addressed some of the non-technical barriers to adopting new irrigation schedules, such as contracts between tomato growers and processors. The panel was moderated by Virginia Lew, Manager of the Energy Efficiency Research Office, and included two local tomato growers and the world's largest tomato processor (Figure 120).

Figure 120: Panel on Processing Tomato led by Virginia Lew from California Energy Commission



Source: PowWow Energy

8.1.3 Closing the Cultural Gap Between Silicon Valley and Central Valley

The interest in closing the cultural gap between the “tech” and “ag” communities was most palpable in the enthusiasm shared by the interns, who came from different backgrounds. PWE

hosted interns from CSU Fresno and CSU San Luis Obispo as well as students in data science from Stanford and computer science from UCSB. The project team also noticed that the new generation of farmers was more interested in learning about new tools and having access to the same tech lifestyle that they have gotten accustomed to with their smart phones.

PWE also participated in local events such as the Woodland incubator “AgStart”, which is now working with UC-ANR to provide a statewide accelerator of new technology innovations in agriculture). The future is bright. It is important, however, to not forget the past. In analyzing technology adoption, the team realized that some of the concepts behind the adoption life-cycle were actually developed by agricultural researchers in the 1950s, as mentioned earlier.

Research in agriculture has led to many technology innovations, and “farming is the ultimate big data problem”, according to Jerry Hatfield, Director of the USDA’s National Laboratory for Agriculture and The Environment in Ames, Iowa. Actually, the first statistical data platform was created for eight land-grant universities to collect data from USDA. It led to the creation of the first general-purpose statistical software and the creation of the SAS Corporation in the 1976 North Carolina.

Figure 121: PWE Staff Participating in an Event in Woodland with the Local Technology Incubator Focused on Agriculture



AgStart is working with UC ANR to develop a statewide network.

Source: University of California, Agricultural and Natural Resources

8.2 Developing Energy Efficiency Program with Utilities

PWE was founded in 2013 and first demonstrated energy savings at three farms in 2013. PWE later expanded in 2014 after winning the Cleantech Open National Prize in November 2013. The inventions in energy data processing and image processing by PWE for the agricultural sector were demonstrated during pilot tests in 2014, and patents were filed before the start of the project that funded its deployment at larger scale. The project team summarizes here the interactions with IOUs before the project (2014) and during the project (2015-2017) to formulate new energy efficiency programs. Analytics platforms exist for the residential and commercial sector, and the farming sector would benefit from a “dashboard” or “energy management system”. Those two terms used by utility staff members are similar to “decision support tool”.

8.2.1 Pacific Gas and Electric (PG&E)

PG&E contracted CIT at CSU Fresno to study the impact of PWE’s Pump Monitor, which was deployed on three farms in 2014.¹⁰¹ The figure below shows the impact of PWE’s tool on a horse ranch near Sacramento (Figure 122). The ranch suffered from leaks in the irrigation system that led to waste in water and energy. The owners were surprised to receive large bills at the end of the month. By receiving alerts from PWE’s analytical tool, they fixed leaks within days and saved over 15% in energy from 2013 to 2014.

Figure 122: History of Energy Use of the Irrigation Pump at a Ranch from 2013 to 2018



The energy use was gradually reduced by fixing leaks (2013 to 2014) and irrigating less frequently (2015 to 2016) by applying water more closely to ET.

Source: PowWow Energy

101 Center for Irrigation Technology, 2014. *Pump Monitor - A Product of PowWow Energy, Inc. - Market and Technology Assessment*. Emeging Technologies report ET 12PGE1401.

This type of savings can be categorized as “behavioral”. PG&E considered expanding its current behavioral programs to agricultural users in 2016 but provided feedback that it would be difficult to measure actual savings, as every farm is different and there is a limited number of farms compared to the large number of residences used for statistical studies to validate behavioral energy savings for residential users. PG&E staff did ask PWE to keep a record of all text communications to back-up the energy savings, and PWE implemented this feature to differentiate “free riders” from “intentional savings”. Figure 123 shows an example of text communication with a pump alert (anomaly detection), followed by a resolution (pump back to normal operation) and an explanation from the farm (cause of the anomaly).

Figure 123: Data Logs to Document Intentional Changes to Save Energy

06/23/2016 04:04 PM	Text	[REDACTED]	PowWow	There was a Plastic Milk Jug caught up in the impellar.
06/23/2016 04:03 PM	Email	PowWow	[REDACTED]	OK: The pump load at D-01 drip station is back to normal. What happened?
06/23/2016 04:03 PM	Text	PowWow	[REDACTED]	OK: The pump load at D-01 drip station is back to normal. What happened?
06/17/2016 02:10 PM	Email	PowWow	[REDACTED]	Warning: You have an unusual pump load at D-01 drip station. Power dropped dramatically from 94 HP to 53 HP on June 12, and is running now at 77 HP.
06/17/2016 02:10 PM	Text	PowWow	[REDACTED]	Warning: You have an unusual pump load at D-01 drip station. Power dropped dramatically from 94 HP to 53 HP on June 12, and is running now at 77 HP.

Series of texts documenting that the fix at the pump is the result of the alert system.

Source: PowWow Energy

The team also looked at the notes from a pilot study with PG&E in 2014, before the start of the EPIC project. It was performed by the Center of Irrigation Technology (CIT) at CSU Fresno. The person from CIT who led the study wrote the following recommendations in his report, and the team implemented the second and fourth points during the project:

- “Continue monitoring Pump Monitor™ and other products that use SmartMeter data.
- Absent enough data to justify a standard subsidy level (as per the pump tests subsidized by APEP), an appropriate level of resources should be allocated to developing and implementing audit efforts using these products. That level is a decision to be made by the IOUs and the CPUC.
- Increase outreach to the customer base to inform them of the availability of this type of data. You cannot manage something you can't measure. SmartMeters provide essential data for all utility customers.
- Continue to develop methods (such as Green Button and Green Button Connect) that make it easier for utility customers to utilize SmartMeter data. This would include some basic level of organization (*e.g.*, easy to read bar charts) and some options for comparison (*e.g.*, energy use last year versus this year).”

The project sponsored by PG&E led to a wider study in 2015 and 2016.¹⁰² PG&E contracted CIT at CSU Fresno and AgH2O to perform a wider market survey of agricultural data. PWE was one of the many vendors interviewed. Based on its report called “Management of Agricultural Energy and Water Use with Access to Improved Data”, PG&E is moving towards integrating their smart meter data in multiple dashboards. Indeed, they support a multi-vendor environment.

¹⁰² Center for Irrigation Technology, 2017. *Management of Agricultural Energy and Water Use with Access to Improved Data*. CIT report, March 2017, 66 pp.

PWE is considered as one of the vendors and currently works on better data integration with pump testers to make adoption easier for growers.

Figure 124 shows a picture of Pump Monitor demonstrated at the World Ag Expo in Tulare with the Mobile Energy Lab sponsored by PG&E for the Advanced Pump Efficiency Program (APEP). It illustrates how growers can make their smart data work for them to measure water, receive automated alerts, and save energy.

Figure 124: Demonstration of SmartMeter Data Analytics at World Ag Expo



Pump test and high-frequency data are integrated by Pump Monitor to provide pump alerts and water use records.

Source: PowWow Energy

In the CIT report, there is a small but important note on “expansion of SmartMeters’ Communication Capability and Function”. Indeed, the second port on the SmartMeter is not open for real-time communication via ZigBee. The first port is used by the IOU to collect data every day for billing purposes. This is what is shared the following day via Green Button programs. However, residential users can purchase devices that connect to the meter to receive real-time data. This port should be open to agricultural users as well, although broadband is not as ubiquitous in rural areas. The CIT report notes: “SmartMeters have data communication capabilities that are currently underutilized in agriculture. Developers and manufacturers of irrigation scheduling software should be made aware of the SmartMeter’s capabilities to stream data that can be captured and incorporated into their software to make energy use and costs part of what the grower evaluates when deciding when and how much water to apply.”

8.2.2 Southern California Edison (SCE)

Staff of SCE met with the staff of PWE at an emerging technology event hosted by the Institute for Energy Efficiency (IEE) at UCSB.¹⁰³ This led to the development of a pilot program in three counties: Ventura, Tulare, and Riverside (Figure 125). The pilot ran in 2017 and will likely be extended in 2018.

Figure 125: Pump Monitor Pilot Sponsored by SCE in Three Counties: Tulare, Ventura, and Riverside

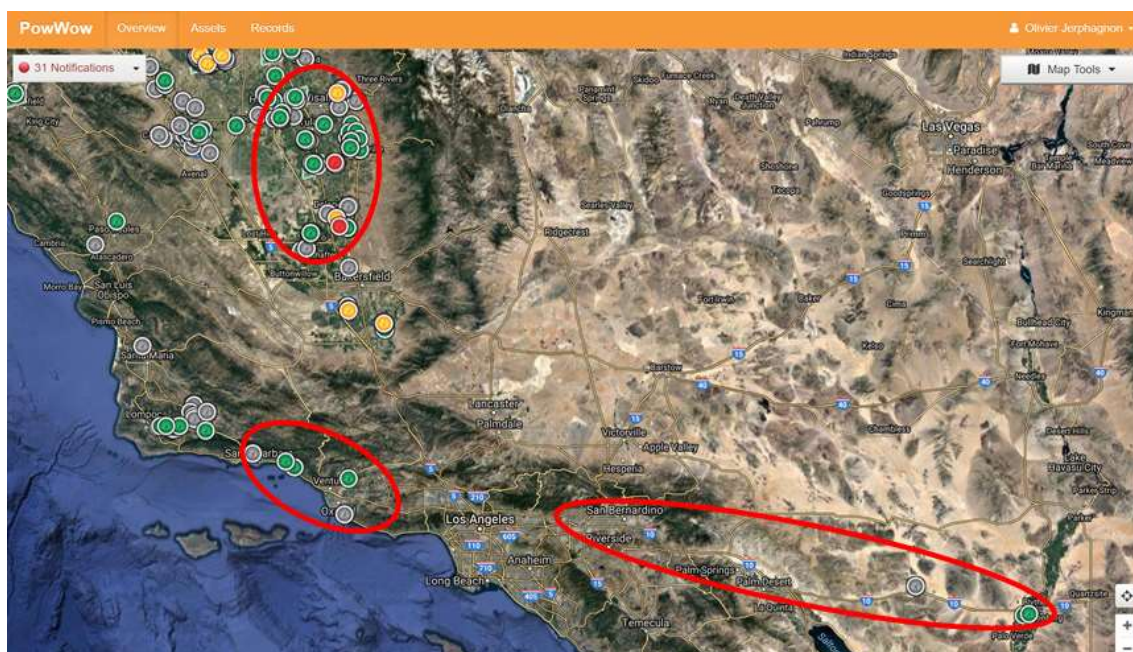

Source: PowWow Energy

SCE is currently the only IOU to recognize Behavioral Recommissioning and Operational (BRO) measures in the agriculture and water sector. It is commonly accepted that the “behavioral” component will disappear, and related savings will be considered either Recommissioning (appliance back to normal operating condition), or Operational (intentional change in operating condition). This is the type of savings that is currently being evaluated to determine the contribution of Pump Monitor to reducing pumping energy intensity (kWh/ac-ft).

As part of the pilot, PWE staff participated in workshops organized by the Cachuma Resource Conservation District (RCD) to understand how farms can benefit from irrigation technologies and work with the community to conserve water in Santa Barbara county. The project identified four priority action areas with significant potential to optimize agricultural water use at this time. These include: “improvements in irrigation scheduling, irrigation system assessments coupled with implementation support, enhanced moisture capture and retention on agricultural

¹⁰³ Institute for Energy Efficiency. *2016 Emerging Technologies Review*. May 27, 2016. iee.ucsb.edu/events/2016-emerging-technologies-review. Accessed Feb. 18, 2018.

lands, and improved coordination in technical assistance for agricultural water decision-makers”.

In addition, the study identified key barriers hindering the adoption of water efficiency practices and includes detailed findings from a countywide agricultural water management survey. One of the barriers is the lack of time for growers to integrate the different sources of information to make a change in irrigation practices. One of the take-aways from the report is to “enhance and coordinate decision support tools to increase adoption of irrigation management best practices”. As a result, the RCD supported the integration of 4 main sources of information during the summer on 2017 onto Pump Monitor as an exercise:

- Pump data and weather forecast (PWE) to make better irrigation decisions
- Pump test (SCE) to assess pump efficiency and offer rebates for pump enhancements
- Irrigation system evaluation via DU testing (free by CRCD or for a fee by vendor)

Figure 126 shows an example of a farm that originally declined to make a change in improving its pumping station. The pump test performed in March showed good OPE performance. Also, the farm used a booster pump for some of the irrigation sets on a steep hill, which was a daunting task.

Figure 126: Farm Near Ventura Participating in the SCE Pilot in 2017



Dashboard view of farm (left) and the distribution of pump power levels used to make pump test recommendation (right). The pump test reported high good efficiency (48.7%) for a power level of 25.4 HP but most of the irrigation is done at 24.5 HP according to historical pump data. A new pump test was performed at that power level, and the efficiency was much lower (38.8%). The farm decided to deploy a VFD.

Source: PowWow Energy

After using Pump Monitor during to check historical water and energy use, it became clear that the pump was not operated efficiently during the summer. The farm had to adjust the pump valve regularly to avoid cavitation. Pump Monitor generated a new pump test form with the most commonly used power levels. A member of the SCE hydraulics team subsequently performed a new pump test in September 2017, and the pump test report showed that energy use could be reduced by 10% by retrofitting the pump or installing a VFD. In parallel, the person from Cachuma RCD had access to the Pump Monitor account thanks to the data sharing capability controlled by the farm. The DU test was uploaded and shared, and the farm worked with the Cachuma RCD to secure cost-sharing funds from NRCS to improve the piping. The

farm then decided to install a VFD to adjust pressure levels and save energy. The expected savings are over 15% from the baseline in 2016 and 2017 and will be monitored by Pump Monitor during the 2018 season.

8.3 Pilots with State and Local Agencies

State and local agencies are part of the water ecosystem, as the Department of Water Resources has oversight on surface water allocation and the newly formed Groundwater Sustainability Agencies (GSAs) will manage groundwater basins. In addition, the California Department of Food and Agriculture (CDFA), and the Resource Conservation Districts (RCDs) administer grants to farms to accelerate the adoption of water efficient technologies.

8.3.1 Statewide Water Efficiency and Enhancement Program (SWEEP)

PWE and CDFA staff members met at the first EPIC symposium in 2015 and discussed the idea of an “audit” or “quantification and validation” tool for carbon-credit programs funded by Cap-and-Trade. The California Air Resources Board requires data to demonstrate GHG reductions.

About a year after the symposium, the CDFA, through a competitive selection process, chose PWE’s platform to monitor water and energy savings for several farm operations receiving State Water Efficiency and Enhancement Program (SWEEP) funds. SWEEP is a CDFA program that provides financial incentives to farmers to implement irrigation practices that save water and reduce greenhouse gas emissions (Figure 127). This an example of successful technology transfer of the project where a pilot-scale platform in 2014 was demonstrated at larger scale during the project in 2015-17 and commercially deployed across California in 2017-20.

Figure 127: List of Enhancements That Can be Supported by SWEEP Funds Managed by CDFA

Pump and Motor Enhancements
Install a variable frequency drive (VFD) (booster pump or well pump)
Motor replacement or efficiency improvement
Pump replacement or efficiency improvement
Irrigation System Enhancements (for systems utilizing pumps)
Install or modify irrigation system that results in a reduction in system pressure
Install automated irrigation system, scheduling, soil moisture sensors, or other techniques to reduce water use that reduce pump demand
Fuel Conversions and Renewable Energy
Change fuel types to less carbon intensive fuel (in conjunction with water savings measures)
Install renewable energy on-site to offset fuel use

Source: California Department of Food and Agriculture

During the 3-year contract, Pump Monitor will validate changes in energy and water usage at those farms and quantify greenhouse gas, energy, and water reductions. Below is the dashboard portal developed by PWE for the CDFA to monitor the savings at a sample of 25 farms located

across California (). The monthly data are aggregated and computed against a baseline year. The privacy of the farms is protected; access to high-frequency data is controlled by the farms. The results were presented in March 2018 at a public event hosted by CDFA.

Figure 128: Example of Dashboard Developed for SWEEP Managed by CDFA

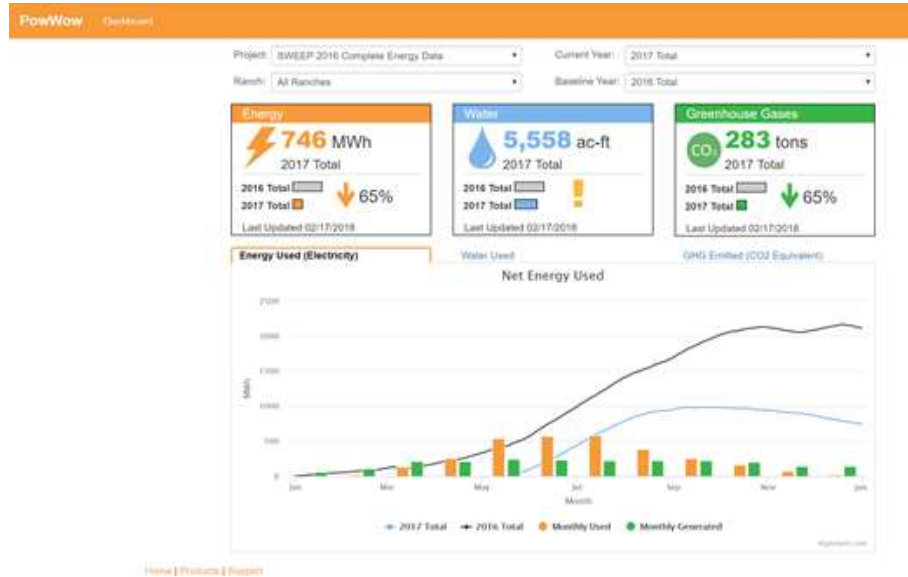

Source: PowWow Energy

8.3.2 Irrigation Evaluations by Resource Conservation Districts (RCD)

Many RCDs were involved in the implementation of SWEEP. They interact with the farms (grant writing) and also verify that the equipment is actually installed (verification). They help with other grant programs such as NRCS projects.

Several RCDs provide system evaluations using the distribution uniformity ¹⁰⁴(DU) measurement designed by CSU San Luis Obispo. They shared that it is time-consuming to perform a DU test, and that the final metric does not tell the whole story about the field. This means that fewer water efficiency projects are implemented although the DU test remains essential. One farm advisor near Ventura stated that simple tests such as DU tests would help farms a lot with managing water. In addition to energy waste, issues with irrigation systems also lead to low crop yield (water stress on part of the field) or disease (too much irrigation on part of the field). Irrigation schedules can only be optimized if the water distribution system runs properly.

A collaborative study identified the correlation between aerial images and on-the-ground DU tests (Figure 129). Two use cases quickly became apparent:

- Present the DU information in a more interactive and useful way to farms. The figure shows the pressure and flow values collected overlaid on a map. This is more helpful than a number that does not mean much to a grower other than “bad” or good”.

¹⁰⁴ Howes, D., Ellenson, S., Hoffmann, L., and Gaudi, Fr., 2015. *Center Pivot Sprinkler Distribution Uniformity Impacts on the Spatial Variability of Evapotranspiration*. J. Irr. and Drain. Eng. 141(8).

- Provide a lay of the land to RCD so they can focus DU tests on the part of the field that has issues and not the rest. DU tests are time consuming and typically are done only on a sample of the field. NDVI imagery before and after DU improvements can be overlaid on a map to show and quantify improvements.

Figure 129: Correlation Between Aerial Imagery and On-the-Ground DU Tests

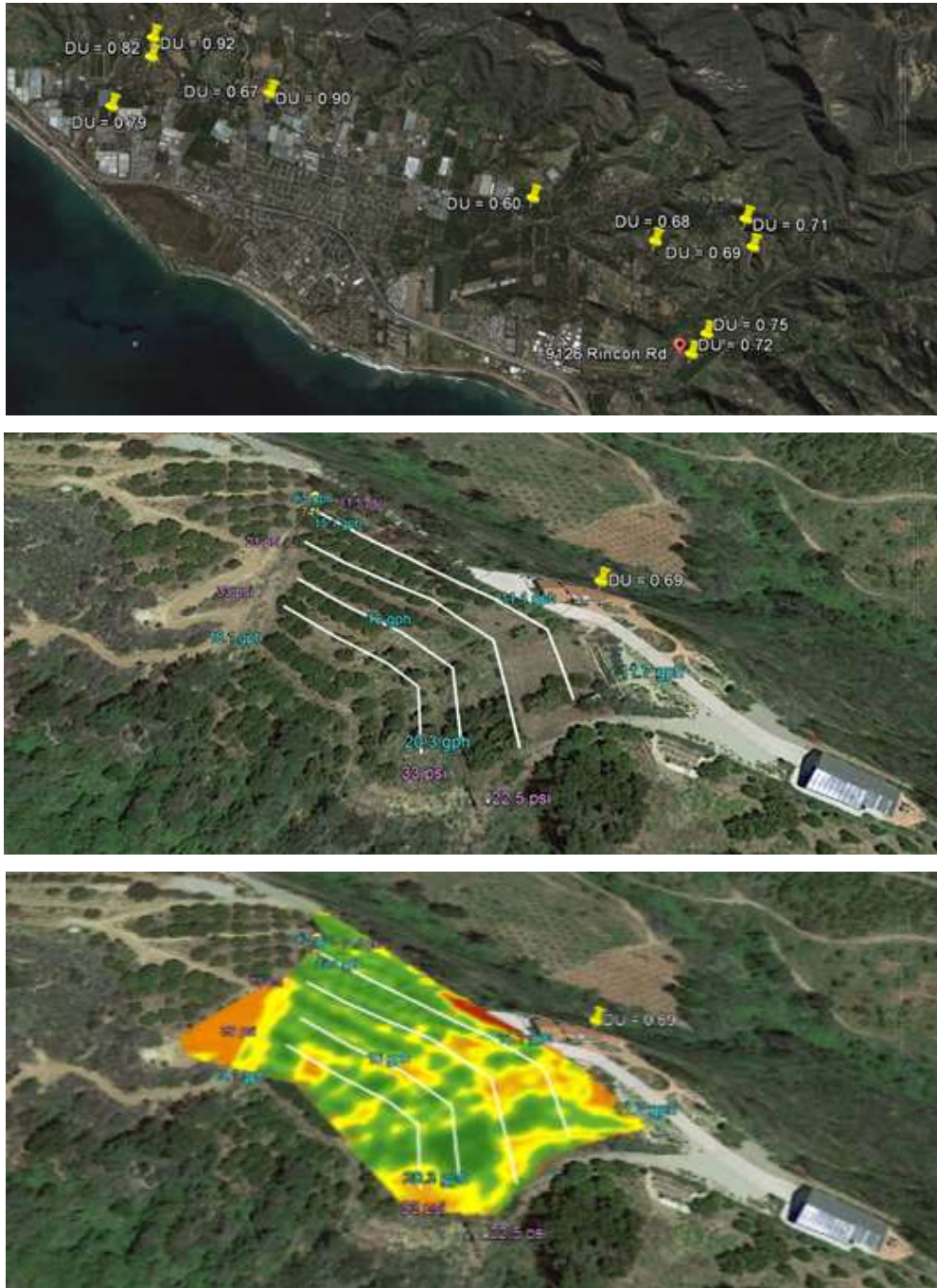

Geo-referenced representation of DU tests (top) with water and pressure data at sampled points in the irrigation system (Middle) and comparison with a vegetation map (bottom).

Source: Cachuma Resource Conservation District and PowWow Energy

8.3.3 Groundwater Sustainability Agencies (GSA)

The work during the EPIC project led to multiple discussions with the California Farm Bureau and the local agencies preparing to implement Groundwater Sustainability Plans (GSPs). Particular attention was paid to the work at Terranova Ranch, which is in a “white area” not serviced by an irrigation district and relies only on groundwater. As a result, the project team talked to several GSAs that are interested in using SmartMeter data to reduce the cost of monitoring and the burden for farms of reporting water records and complying with SGMA. Pump Monitor has been selected to test its platform at three GSAs in California ahead of the GSP implementation in 2020. One GSA is managed by a district (mix of groundwater and surface water), one is managed by a board comprised of local farmers (groundwater only), and one receives water from federal projects (mix of federal surface water and ground water).

The work performed with deficit irrigation takes on a new meaning within the context of GSAs, which must balance water demand and supply during wet and dry years and maintain ground water levels. New water efficiency programs that use decision support tools such as Irrigation Advisor should be used in the context of GSPs. Farms could receive an incentive to apply less water during dry years (deficit irrigation without negatively impact yield) and apply more water off-season (flood the fields in the winter without negatively impacting yield) to help balance the water table and ensure the sustainability of farming for decades to come. This has the benefit of reducing the energy required to pump groundwater, as the water depth will remain more stable. For example, the water table at Terranova Ranch has dropped by 2 feet on average in the last 10 years according to Kings RCD. This represents an increase in energy use of 2% every year for a water table at 200 feet depth. The constant drop in groundwater levels is the “elephant in the room”. It trumps all other energy saving ideas in agriculture. Maintaining the groundwater table is the biggest energy efficiency measure that California can promote in agriculture. In 2017, Terranova Ranch applied 7,000 ac-ft of storm water on more than 500 acres (Figure 130). It helped improve the water table by 10 feet from October 2016 to October 2017. Terranova Ranch is using Pump Monitor to track water use (extraction and recharge) and monitor the water levels.

Figure 130: Groundwater Recharge Experiment at a Vineyard at Site #6 Near Fresno

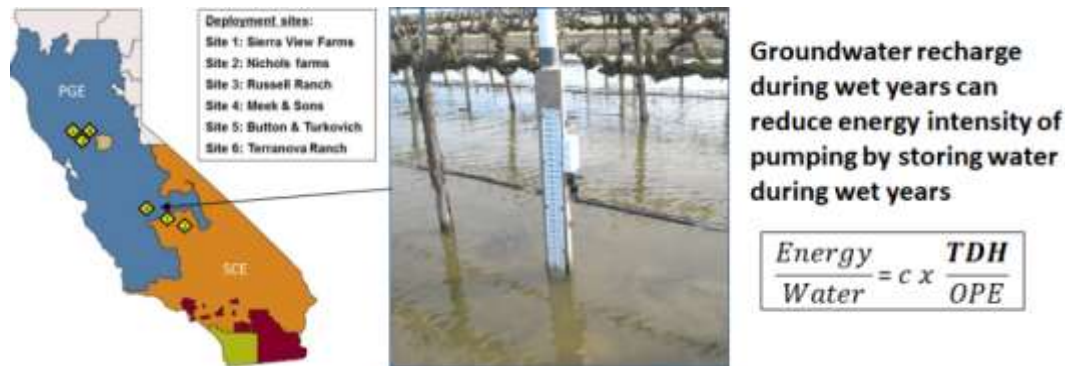

The energy intensity of pumping is proportional to the total dynamic head (TDH) that varies with the water table. A reduction in water depth thanks to groundwater recharge therefore reduces energy use.

Source: Terranova Ranch (photo of flooded vines) and PowWow Energy

CHAPTER 9:

Conclusions and Recommendations

The work during the project demonstrated, at large scale, the integration of new technologies and advanced crop models into a decision-support tool that will (a) make the daily life of growers less complicated with respect to maintaining pumping infrastructure, and (b) provide a safety net to reduce irrigation in drought years without negatively impacting crop yields. As a result, the decision support tool can assist farms in reducing the level of energy and water use (inputs) for the same level of crop yield (output). The project team observed an average of 13% in overall energy reduction across the sites — 4% from pump monitoring and 9% from optimizing irrigation scheduling.

However, the team learned several lessons during the project that the team would like present in the form of recommendations for future energy efficiency and water conservation programs:

1. **Monitoring of the farm from “pump to nozzle”.** Energy savings are optimized when adjustments are coordinated across the irrigation system. If the pressure requirement is improved without adjusting the operating point of the pump, savings will not materialize. If a pump is not maintained, it can severely impact the distribution uniformity of the water applied to the field and negatively affect crop yields. Every farm is different, and energy savings varied across deployments varied from 1% to 24%. The team measured a weighted average (by acreage) of 4% in energy savings as a result of pump monitoring.
2. **Promoting deficit irrigation in dry years together with groundwater recharge in wet years.** The consistent reduction of 9% in water and energy consumption that the team observed across different crops resulting from optimizing irrigation schedules should be deployed in tandem with groundwater recharge in wet years. Surface water has a smaller energy footprint at the farm. Applying more water during wet winters does not negatively impact the electricity grid and has multiple benefits for farming in the long run by leaching the soils and recharging the aquifer. This in turn reduces the energy intensity of groundwater pumping in dry years.

The project team discuss these two recommendations in more detail in the sub-sections below.

9.1 Use Simple Decision-Support Tool as Farming Dashboard

When the team started the project, it explored the application of PWE’s data analytics platform as a behavioral measure, as is the case in residential programs. The team learned that the main challenge in the water and agriculture sectors is to measure accurately and verify energy savings because there are many external factors that affect energy consumption. In addition, adoption by growers can be slow and they would benefit from a complete dashboard from “pump to nozzle” to simplify their daily activities. As a result, the project team recommends that a decision-support tool such as Pump Monitor be sponsored by IOUs as a farming

dashboard with built-in Measurement & Verification (M&V) capabilities to audit existing energy efficiency or water conservation programs in agriculture. Such an audit tool can be used for on-bill energy financing or behavioral-retro-commissioning and operational (BRO) programs. Energy savings can be measured at the meter rather than pre-calculated on design principles.

The energy savings that can be allocated to a dashboard such as Pump Monitor could be presented instead as an incentive to use an energy and water management system tailored for farms. Having all the information on one dashboard makes life easier for growers dealing with constant weather changes. This could help offset the up-front cost for growers to register their pumps onto a dashboard. The project team estimates that the energy savings from a simple decision support tool such as Pump Monitor is on the order of 4% but will vary from farm to farm as reported in the project. An example of dashboard is shown in Figure 131.

Figure 131: Energy and Water Management Dashboard for Farms

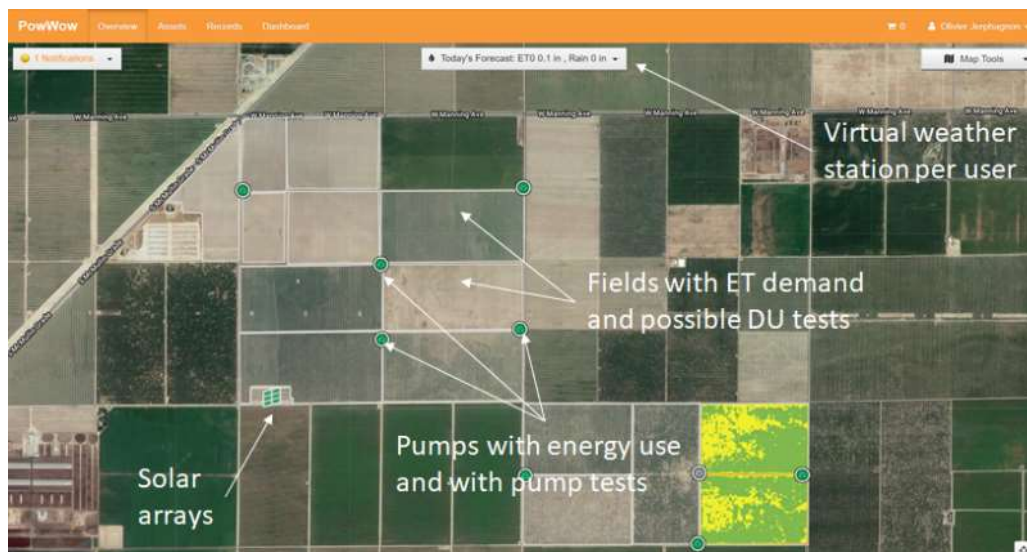

Source: PowWow Energy

The remaining technical question is how a dashboard can be used to measure and verify energy savings from other measures requiring hardware installations? Possible projects at the farm include reducing water application based on a scientific reference such as an ET station or soil moisture probes, reducing the operating pressure with low-pressure nozzles, the injection chemicals injected in the irrigation system, the re-piping of main lines, etc.

As described in Chapter 7, it is important to set a baseline and capture the external factors that can affect the energy use. This includes changes in the water table but also weather and any surface allocation. Having all the weather and water information integrated in the dashboard allows to measure and verify the savings at the ranch level (water management unit).

This approach was used for the implementation of the Pump Monitor™ product by CDFA for the Statewide Water Efficiency and Enhancement Program (SWEEP). Similarly, it can be used to streamline a set of energy efficiency programs that better responds to the needs of farms and provide actionable information to growers in the context of their daily activities.

9.2 Coordinate Advanced Decision Support Tool (Deficit Irrigation) with Groundwater Recharge to Manage Crops During Dry and Wet Years

The project team demonstrated that the deployment of deficit irrigation has benefits to the farms and the electrical grid. The increase in water use efficiency was consistently around 9% across crops. An advanced decision-support tool is necessary to achieve the water and energy savings without putting at risk crop production. One IOU staff member expressed that it would be difficult to use such a program because it would happen primarily in drought years. One approach to create a year-to-year program would be to coordinate deficit irrigation (dry years) with groundwater recharge (wet years) with the same irrigation support tool.

Indeed. The constant drop in water table is arguably the biggest source of energy increase in agriculture. For an average well pump with a water depth of 200 feet, an average drop of 2 feet per year means an increase in energy of 1% every year. Over time it represents a very large increase in energy consumption. As a result, the size of pumps has increased in the last 20 years. Where 100 horsepower pumps were common, it is not rare to see now 200 horsepower pumps. Advanced irrigation practices should be considered in the context of the goal of Groundwater Sustainable Plans (GSP) to maintain the groundwater levels. The concept of balancing water demand and supply was discussed at the Education Tech Center (Figure 132).

Figure 132: Panel on Recharging Groundwater During Wet Years in the San Joaquin Valley



Sargeant Green from the California Water Institute discusses the preliminary findings of groundwater recharge with Don Cameron from Terranova Ranch and Aaron Fukuda from Tulare Irrigation District

Source: PowWow Energy

A few important take-ways from the panelists:

- The growers with data will be able to cope with SGMA, and the growers without data will have a harder time surviving future regulation;
- Water measurement from energy meters is surprisingly accurate on a farm scale. A farm compared the numbers from PowWow to theirs and they were very close;
- The more years of data that farms have, the easier it will be for them to defend what normal use is;

- Some farms think data is “bad” because it will reveal too much about their farming operation, but that data can protect their allocation if groundwater becomes limited;
- The electric utilities such as PG&E and SCE should work together with the GSAs because the water usage limitations are going to make the energy demand much more consistent across dry and wet years;
- Groundwater Sustainability Plans (GSP) will be based on data and having good water usage data will be necessary to implement good GSP at the basin level.

Another application for advanced decision support tools, such as Irrigation Advisor™, is to help farms implement on-farm groundwater recharge during wet years in order to maintain the groundwater level. The application of additional water is indeed crop dependent. Crops such as wine grapes can take more water into early summer compared to other crops such as almonds. The project team therefore recommend the use of advanced decision support tools in farming to implement both deficit irrigation and groundwater recharge and enable an on-going program. It is difficult for farms to adopt new technologies in just one season, as it takes time to learn how to use a new platform. For instance, the groundwater savings from deficit irrigation and groundwater recharge could be considered as “water credits” by the local water agencies, or as a source of energy savings by power utilities. As an illustration, the team simulated the deployment of deficit irrigation and groundwater recharge on 20% of the farmed land in California (Figure 133). The result shows that the energy load of water and agriculture in 2016 would be at the same level as 2007.

Figure 133: Possible Impact of Implementing Deficit Irrigation and Groundwater Recharge

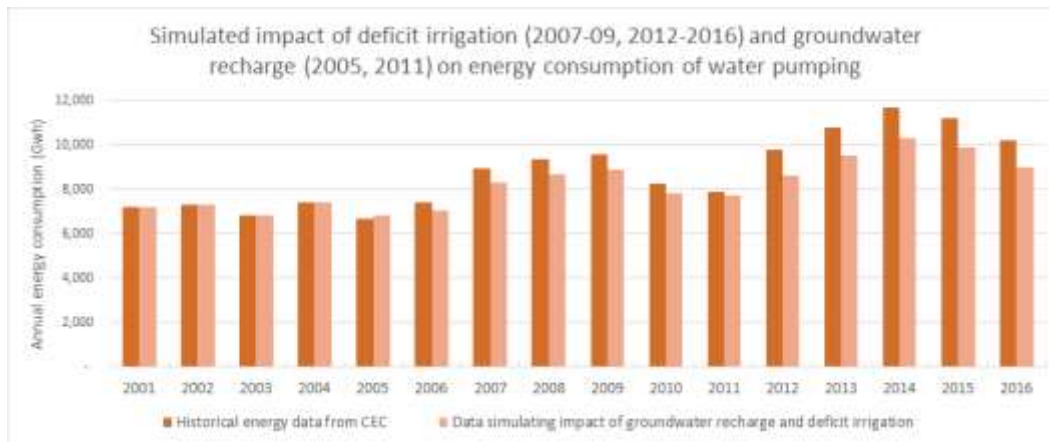

Source: California Energy Commission (historical data) and PowWow Energy (simulated data)

The California Energy Commission and IOUs should pay attention to the development of GSPs because it will affect the energy load in rural areas such as San Joaquin Valley. On the farm side, growers should embrace data as a vehicle to protect their farming operations and increase the value of their water assets. Privacy remains a primary concern among growers. Water agencies should reflect on the success of the Green Button data sharing program. It protects the privacy of end-users, and it enabled many new applications that have value to both value the end-users (*e.g.*, farms) and the community (*e.g.*, water and energy resources).

LIST OF ACRONYMS AND ABBREVIATIONS

Term	Definition
ABC	Almond Board of California
Ac-Ft	Acre-Foot
ADR	Amplitude Domain Reflectometry
AMI	Advanced Metering Infrastructure
APEP	Advanced Pump Efficiency Program
ASI	Agricultural Sustainability Institute
API	Application Program Interfaces
AWC	Available Water Capacity
BRO	Behavioral Recommissioning and Operational
CCR	California Code of Regulations
CDEFA	California Department of Food and Agriculture
CIMIS	California Irrigation Management Information System
CIT	Center for Irrigation Technology at CSU Fresno
CMD	Connect My Data
CPR	Critical Project Review
CPUC	California Public Utility Commission
CSU	California State University
CSV	Comma-Separated Value
DI	Deficit Irrigation
DIL	Deficit Irrigation level
DMD	Download My Data
DU	Distribution Uniformity
DWR	California Department of Water Resources
EPIC	Electric Program Investment Charge
ESPI	Energy Service Provider Interface
ET	Evapotranspiration
ET ₀	Reference ET
ET _c	Crop ET
ET _a	Actual crop ET
ETCC	Emerging Technology Coordinating Council

Term	Definition
FDR	Frequency Domain Reflectometry
FOV	Field of View
GHG	Greenhouse gas
GIS	Geospatial Information System
GPM	Gallon Per Minute
GSA	Groundwater Sustainability Agency
GSP	Groundwater Sustainability Plan
GW	Gigawatt
GWh	Gigawatt-hour
H	Pump head
HP	Horsepower
IETF	Internet Engineering Task Force
kW	Kilowatt
kWh	Kilowatt-hour
IOU	Investor- Owned Utility
ITRC	Irrigation Training and Research Center at CSU San Luis Obispo
K_c	Crop Coefficient
LCA	Life Cycle Assessment
M&V	Measurement and Verification
MW	Megawatt
MWh	Megawatt-hour
NAESB	North American Energy Standards Board
NDVI	Normalized Difference Vegetation Index
NIST	National Institute for Standards and Technology
NRCS	Natural Resources Conservation Service
NWS	National Weather Service
OPE	Overall Pumping Plant Efficiency
P_e	Effective precipitation
PG&E	Pacific Gas and Electric
PI	Primary Investigator

Term	Definition
PM	Project Manager
PPE	Personal Protective Equipment
PWE	PowWow Energy
Q	Pump flow rate in gallons per minute
RCD	Resource Conservation District
RDI	Regulated Deficit Irrigation
RPM	Rotation Per Minute
SaaS	Software-as-a-Service
SB-88	Senate Bill 88
SCE	Southern California Edison
SDD	Stress Degree Day
SDG&E	San Diego Gas and Electric
SDI	Subsurface Drip Irrigation
SGMA	Sustainable Groundwater Management Act
SPAC	Soil-Plant-Atmosphere Continuum
SSP	Single Speed Pump
SWEEP	Statewide Water Efficiency and Enhancement Program
SWP	Stem Water Potential
TAC	Technical Advisory Committee
TDH	Total Dynamic Head
TDR	Time Domain Reflectometry
TDT	Time Domain Transmissivity
TW	Terawatt
TWh	Terawatt-hour
UC ANR	University of California Agriculture and Natural Resources
UC CE	University of California Cooperative Extension
UCD	University of California, Davis
UCSB	University of California, Santa Barbara
USGS	United States Geological Survey
VFD	Variable Frequency Driver

Term	Definition
VSP	Variable Speed Pump
WUI	Water Use Intensity

REFERENCES

- Advanced Pump Efficiency Program. *Advanced Pumping Efficiency Program (APEP) - Pump Testers*. www.pumpefficiency.org/pump-testing/pump-testers. Accessed 12 Feb. 2018.
- Allen, R., Tasumi, M. and Trezza, R., 2007. *Satellite-Based Energy Balance for Mapping Evapotranspiration with Internalized Calibration (METRIC)—Model*. J. Irrig. Drain Eng., 133(4), 380-394.
- Allen, R.G., Pereira, L.S., Raes, D. and Smith, M., 1998. *Crop evapotranspiration: guidelines for computing crop water requirements*. Irrigation and Drainage Paper no. 56. FAO, Rome, Italy, 300 pp.
- Bastiaanssen, W., Noordman, E., Pelgrum, H., Davids, G., Thoreson, B. and Allen, R., 2005. *SEBAL Model with Remotely Sensed Data to Improve Water-Resources Management under Actual Field Conditions*. J. Irrig. Drain Eng., 131(1), 85-93.
- Bohlen, J.M. and Beal, G.M., 1957. *The Diffusion Process*. Special Report No. 18. Agriculture Extension Service, Iowa State College. 1: 56-77.
- Brouwer, C. and Heibloem, M., 1986. *Irrigation water management: Irrigation water needs*. Food and Agriculture Organization of the United Nations, Training Manual No. 3, Rome, Italy.
- Brown, E.G. *Governor's Clean Energy Jobs Plan*. gov.ca.gov/docs/Clean_Energy_Plan.pdf. Accessed 12 Feb. 2018.
- Burt, C., 2017. *Using Electricity Consumption to Estimate Water Volumes Pumped from Wells*. Irrigation Training and Research Center (ITRC) at CSU San Luis Obispo. ITRC Publication No. P 17-001, 8 pp.
- California Air Resources Board, 2014. *First Update to the Climate Change Scoping Plan: Building on the Framework, Pursuant to AB32, The California Global Warming Solutions Act of 2006*. Sacramento, CA: Air Resources Board, p. 62.
- California Department of Water Resources, 2014. *California Groundwater Elevation Monitoring: Basin Prioritization Process: June, 2014*. Sacramento, CA: Department of Water Resources, p. 6.
- California Department of Water Resources, 2009. *California Water Plan Update 2009*. http://www.waterplan.water.ca.gov/docs/cwpu2009/0310final/v2c02_agwtruse_cwp2009.pdf
- California Department of Water Resources. *Groundwater Sustainability Agencies*. www.water.ca.gov/Programs/Groundwater-Management/SGMA-Groundwater-Management/Groundwater-Sustainable-Agencies. Accessed 12 Feb. 2018.
- California Department of Water Resources. *CASGEM Online System*. www.casgem.water.ca.gov/OSS. Accessed 12 Feb. 2018.
- California Department of Water Resources. *Agricultural Water Use Efficiency*. www.water.ca.gov/Programs/Water-Use-And-Efficiency/Agricultural-Water-Use-Efficiency. Accessed 15 Feb. 2018.
- California Energy Commission, 2012. *The Electric Program Investment Charge: Proposed 2012-2014 Triennial Investment Plan, Staff Report*. Publication Number: CEC-500-2012-082-SF, p. 1.
- California Energy Commission, 2013. *2013 Integrated Energy Policy Report*. Publication Number: CEC-100-2013-001-CMF, p. 1.

- California Energy Commission. *Agriculture and Food Processing Research*. www.energy.ca.gov/research/iaw/agriculture.html. Accessed 17 Feb. 2018.
- California Energy Commission. *EPIC Symposium Helps Create Agricultural Water and Energy Saving Partnership*. Jun. 27, 2017. calenergycommission.blogspot.com/2017/06/epic-symposium-helps-create.html. Accessed Feb. 18, 2018.
- California Public Utilities Commission, 2011. *Energy Efficiency Strategic Plan: January 2011 Update*. p. 47. www.cpuc.ca.gov/PUC/energy/Energy+Efficiency/eesp.
- Center for Irrigation Technology at CSU Fresno, 2013. *Irrigation Systems Water/Energy Evaluations Market and Technology Assessment*. Publication number: ET12PGE1401.
- Center for Irrigation Technology, 2014. *Pump Monitor - A Product of PowWow Energy, Inc. - Market and Technology Assessment*. Emerging Technologies report ET 12PGE1401.
- Center for Irrigation Technology, 2017. *Management of Agricultural Energy and Water Use with Access to Improved Data*. CIT report, March 2017, 66 pp.
- Chopra, A. *Modeling a Green Energy Challenge after a Blue Button*. The White House, 15 September 2015. www.whitehouse.gov/blog/2011/09/15/modeling-green-energy-challenge-after-blue-button. Accessed 12 Feb. 2018.
- Doll, D. and Shackel, K., 2015. Drought Management for California Almonds. *Impacts of Stress on Almond Growth and Yield*. Pub. 8515. UCANR Publications.
- Farré, I., and Faci, J. M., 2006. Comparative response of maize (*Zea mays* L.) and sorghum (*Sorghum bicolor* L. Moench) to deficit irrigation in a Mediterranean environment. *Agricultural Water Management*, 83(1), 135-143.
- Favati, F., Lovelli, S., Galgano, F., Miccolis, V., Di Tommaso, T. and Candido, V., 2009. *Processing tomato quality as affected by irrigation scheduling*. *Sci. Hort.*, 122, pp. 562-57.
- Fereres, E. and Goldhamer, D.A., 1990. *Deciduous fruit and nut trees*. In: Stewart, B.A. and Nielsen, D.R. (eds). *Irrigation of agricultural crops Mon.#30*. American Society of Agronomy, Madison WI, pp. 987-1017.
- Fereres, E. and Soriano, M.A., 2007. *Deficit irrigation for reducing agricultural water use*. *Journal of Experimental Botany*, 58(2), 147-159.
- Ferguson, L., Beede, R.H., Freeman, M.W., Haviland, D.R., Holtz, B.A. and Kallsen, C.E., 2005. *Pistachio Production Manual*. Fruit and Nut Research and Information Center, 4th ed. University of California, Davis, CA.
- Girona, J., Mata, M., Goldhamer, D.A., Johnson, R.S., and DeJong, T.M., 1993. *Patterns of soil and tree water status and leaf functioning during regulated deficit irrigation scheduling in peach*. *Journal of the American Society for Horticultural Science*, 118(5), 580-586.
- Goldhamer, D.A. and M. Viveros, 2000. *Effects of preharvest irrigation cutoff durations and postharvest water deprivation on almond tree performance*. *Irrig. Sci.* 19:125-131.
- Goldhamer, D.A. and Beede, B.H., 2004. *Regulated deficit irrigation effects on yield, nut quality and water-use efficiency of mature pistachio trees*. *Journal of Horticultural Science & Biotechnology* 79 (4) 538-545.
- Goldhamer, D.A. and Holtz, B., 2009. *Rational Early Season Drought Planning for Almond Growers*. *The Pomology Post*. Madera County. Vol. 59, March, 2009.
- Goldhamer, D.A., 2005. *Irrigation Management*. In: *University of California Pistachio Production Manual*. Edited by L. Ferguson. pgs. 103-116.

- Goldhamer, D.A., Beede, R., Moore, J.M., Weinberger, G. and Menezes, J., Jr., 1983. *Water use requirements and physiological response to water stress in pistachio*. Annual report of the California Pistachio Commission, Crop Year 1982 - 1983, pgs. 53-57.
- Goldhamer, D.A., Kjelgren, R., Beede, R., Williams, L., Moore, M.J., Lane, J., Weinberger, G. and Menezes, J., 1985. *Water use requirements of pistachio trees and response to water stress*. Annual report of the California Pistachio Commission, Crop Year 1984 - 1985, pgs. 85-92.
- Goldhamer, D.A., Viveros, M. and Salinas, M., 2006. *Regulated deficit irrigation in almonds: Effects of variations in applied water and stress timing on yield and yield components*. Irrigation Science 24(2):101-114.
- Goodwin, I. and Boland, A.M., 2002. *Scheduling deficit irrigation of fruit trees for optimizing water use efficiency*. In: *Deficit Irrigation Practices*. Water Reports No. 22. FAO. Rome, Italy, pp. 67-78.
- Govender M., Dye P.J., Weiersbye I.M., Witkowski E.T.F. and Ahmed F., 2009. *Review of commonly used remote sensing and ground-based technologies to measure plant water stress*. Water SA, 35: 741-752. [dx.doi.org/10.4314/wsa.v35i5.49201](https://doi.org/10.4314/wsa.v35i5.49201).
- Hanson, B., and May, D.M., 2006. *New crop coefficients developed for high-yield processing tomatoes*. California Agriculture, 60(2):95-99.
- Hanson, B., Orloff, S., and Sanden, B., 2007a. *Monitoring Soil Moisture for Irrigation Water Management*. Publication 21635. University of California Agriculture and Natural Resources, Oakland, CA, 48 pp.
- Hanson, B., Putnam, D., and Snyder, R., 2007b. *Deficit irrigation of alfalfa as a strategy for providing water for water-short areas*. Agricultural Water Management 93, 73-80.
- Hardin, G., 1968. *The Tragedy of the Commons*. Science Magazine. 162 (3859): 1243-1248. doi:10.1126/science.162.3859.1243. PMID 5699198.
- Howes, D., Ellenson, S., Hoffmann, L., and Gaudi, Fr., 2015. *Center Pivot Sprinkler Distribution Uniformity Impacts on the Spatial Variability of Evapotranspiration*. Journal of Irrigation and Drainage Engineering, Volume 141 Issue 8.
- Howitt, R.E., Medellin-Azuara, J., MacEwan, D., Lund, J.R. and Sumner, D.A., 2014. *Economic Analysis of the 2014 Drought for California Agriculture*. Center for Watershed Sciences, University of California, Davis, California, p. 3. watershed.ucdavis.edu.
- Hsiao, T.C. 1973. *Plant responses to water stress*. Annual Review of Plant Physiology 24, 519-570.
- Irrigation Training and Research Center, 2011. *Agricultural Water Energy Efficiency*. California Energy Commission. Publication number: CEC-500-06-040.
- Institute for Energy Efficiency. *2016 Emerging Technologies Review*. May 27, 2016. iee.ucsb.edu/events/2016-emerging-technologies-review. Accessed Feb. 18, 2018.
- Jackson, R.D., Reginato, R.J. and Idso, S.B., 1977. *Wheat canopy temperature: A practical tool for evaluating water requirements*. Water Resour. Res. 13: 651-656.
- Jerphagnon, O. *Methods to detect anomalies and to measure water usage in pumping plants using energy data*. U.S. Patent No. 9.823,156 November 21, 2017.
- Johnstone, P.R., Hartz, T.K., LeStrange, M., Nunez, J.J. and Miyao, E.M., 2005. *Managing fruit soluble solids with late-season deficit irrigation in drip-irrigated processing tomato production*. HortScience, 40(6), 1857-1861.

- Kang, S., Shi, W. and Zhang, J., 2000. *An improved water-use efficiency for maize grown under regulated deficit irrigation*. Field Crops Research, 67(3), 207-214.
- Keinonen, I. and Jones, H., 2004. *Combining thermal and visible imagery for estimating canopy temperature and identifying plant stress*. Journal of Experimental Botany, Vol. 55, No. 401, pp. 1423-1431.
- Lampinen, B., Dejong, T., Weinbaum, S., Metcalf, S., Negron, C., Viveros, M., Mc Ilvane, J., Ravid, N. and Baker, B., 2007. *Spur dynamics and almond productivity*. Modesto: 2007-2008 Annual Management Website: ucmanagedrought.ucdavis.edu.
- Ley, T., Stevens, R.G., Topielec, R.R. and Neibling, W.H., 1996. *Soil Water Monitoring and Measurement*. Washington State University Cooperative Extension; the Oregon State University Extension Service; and the University of Idaho Cooperative Extension System. Pacific Northwest Extension Publication 475.
- McCarthy, M.G., Loveys, B.R., Dry, P.R. and Stoll, M., 2002. *Regulated deficit irrigation and partial rootzone drying as irrigation management techniques for grapevines*. In: *Deficit Irrigation Practices*. Water Reports No. 22. FAO. Rome, Italy, pp. 79-87.
- McCrometer, 2016. *Quotation for 6" M0300 bolt-on-saddle mechanical flow meter*. Quote received on 11/8/2016. Quote number: 148086.
- McCrometer. *Specification sheet for 6" McPropeller Bolt-on Saddle Flow Meter*. www.mccrometer.com/asset-get.download.jsa?id=52003821449. Accessed 12 Feb. 2018.
- McCutchan, H. and Shackel, K.A., 1992. *Stem water potential as a sensitive indicator of water stress in prune trees (Prunus domestica L. cv. French)*. Journal of the American Society for Horticultural Research, 117, 606-611.
- Micke, W.C., 1996. *Almond production manual*. Division of Agriculture and Natural Resources, University of California, Oakland, CA. 289 pp.
- National Science Foundation. CyberSEES: Type2: *SmartFarm - Research and Education for Sustainable Agriculture Practices*. www.nsf.gov/awardsearch/showAward?AWD_ID=1539586. Accessed 12 Feb. 2018.
- Navigant Consulting, Inc., 2006. *Refining Estimates of Water-Related Energy Use in California*. California Energy Commission, PIER Industrial/Agricultural/Water End Use Energy Efficiency Program. CEC-500-2006-118, pg. 39.
- Orloff, S., Bali, K. and Putnam, D., 2014. *Deficit irrigation of alfalfa and grasses: What are the impacts/options?* Proceedings, 2014 California Alfalfa, Forage, and Grain Symposium, Long Beach, CA, 10-12 December, 2014. UC Cooperative Extension, Plant Sciences Department, University of California, Davis, CA.
- Patanè, C. and Cosentino, S.L., 2010. *Effects of soil water deficit on yield and quality of processing tomato under a Mediterranean climate*. Agricultural Water Management, 97, pp. 131-138.
- Patanè, C., Tringali, S. and Sortino, O., 2011. *Effects of deficit irrigation on biomass, yield, water productivity and fruit quality of processing tomato under semi-arid Mediterranean climate conditions*. Scientia Horticulturae, 129(4), 590-596.
- Phene, B.C., Goldhamer, D.A., Menezes, J., Beede, R., Weinberger, G. and Cervantes, Z., 1987. *Response of Pistachio Trees to Three Consecutive Years of Irrigation Cut-off*. In Annual Report, Crop Year 1986-1987.
- Pollock, D., 2017. *Data integration critical to maximize farm productivity, resource efficiency*. Western Farm Press issue of October 30, 2017.

www.westernfarmpress.com/technology/data-integration-critical-maximize-farm-productivity-resource-efficiency.

- Pollock, D., 2017. *Growers express interest in groundwater monitoring*. AgAlert, the weekly newspaper by the California Farm Bureau Federation. Issue of October 4, 2017, p. 9.
- PowWow Energy. *Pump Monitor™ web service*. www.powwowenergy.com. Accessed 12 Feb. 2018.
- Prichard, T., Asai, W., Verdegaal, P., Micke, W. and Teviotdale, B., 1994. *Effects of water supply and irrigation strategies on almonds*. Modesto: Almond Board of California. Comprehensive Project Report 1993-94.
- Pruitt, W.O. and Doorenbos, J., 1977. *Empirical calibration, a requisite for evapotranspiration formulae based on daily or longer mean climatic data?* In: *Proceedings of the International Round Table Conference on "Evapotranspiration"*, International Commission on Irrigation and Drainage, Budapest, Hungary, 20 pp.
- Rodriguez, J., 2016. *We use aerial spectral imagery to optimize water and nitrogen*. Presentation provided as public comment at workshop organized by California Energy Commission on 11 Oct. 2016. docketpublic.energy.ca.gov/PublicDocuments/16-OII-01/TN213953_20161011T084905_Ceres_Imaging_We_use_aerial_spectral_imagery_to_optimize_water.pdf. Accessed 12 Feb. 2018.
- Sandoval, C., 2014. *California Water/Energy Efficiency Proceedings*. 19 Jun. 2014. www.cpuc.ca.gov/uploadedFiles/CPUC_Public_Website/Content/About_Us/Organization/Commissioners/Catherine_Sandoval/June_2014-Water_Energy_Nexus.pdf. Accessed 13 Feb. 2018.
- Saint John, J. *Turning smart meters into water leak detectors*. Greentech Media, 17 December 2013. www.greentechmedia.com/articles/read/turning-smart-meters-into-water-leak-detectors#gs.4qzBFmg. Accessed 12 Feb. 2018.
- Scholander, P.F., Hammel, H.T., Hemmingsen E.A. and Bradstreet, E.D., 1964. *Hydrostatic pressure and osmotic potential in leaves of mangroves and some other plants*. Proc. Natl. Acad. Sci. U.S.A. 52:119-125.
- Schwankl, L.J., Prichard, T.L., Hanson, B.R., and Elkins, R.B., 2007. *Understanding your Orchard's Water Requirements*. Publication number 8212, University of California Division of Agriculture and Natural Services. Oakland, CA, 10 pp.
- Seametrics, 2016. Specification sheet for AG 2000 8" Magnetic Flow Meter. Available online at: <http://www.seametrics.com/product/ag2000-magnetic-flow-meter>.
- Sethuraman, S., 2014. *Communications - Water/Energy Workshop, CPUC, September 10, 2014. Presentation from Manager of Industrial, Agricultural & Water Programs at PG&E*. docs.cpuc.ca.gov/PublishedDocs/Efile/G000/M167/K737/167737883.PDF. Accessed 13 Feb. 2018.
- Shackel, K., Lampinen, B., Sibbett, S. and Olson, W., 2000. *The relation of midday stem water potential to the growth and physiology of fruit trees under water limited conditions*. Acta Hort. 537:425-430.
- Shackel, K., Buchner, R., Connell, J., Edstrom, J., Fulton, A., Holtz, B., Lampinen, B., Reil, W. and Viveros, M., 2004. *Final Report: Deficit Irrigation Management During Hull Split*. Modesto: Final Report to The Almond Board of California.
- Shackel, K.A., H. Ahmadi, W. Biasi, R. Buchner, D. Goldhamer, S. Gurusinghe, J. Hasey, D. Kester, B. Krueger, B. Lampinen, G. McGourty, W. Micke, E. Mitcham, B. Olson, K. Pelletrau, H. Philips, D. Ramos, L. Schwankl, S. Sibbett, R. Snyder, S. Southwick, M. Stevenson, M.

- Thorpe, S. Weinbaum, and J. Yeager, 1997. *Plant water status as an index of irrigation need in deciduous fruit trees*. HortTechnology 7:23-29.
- Shapland, T.M., McElrone, A.J., Snyder, R.L. and Paw U, K.T., 2012. *Structure function analysis of two-scale scalar ramps. Part I: theory and modeling*. Boundary-layer Meteorology, 145(1), 5-25.
- Shapland, T.M., McElrone, A.J., Snyder, R.L. and Paw U, K.T., 2012. *Structure function analysis of two-scale scalar ramps. Part II: ramp characteristics and surface renewal flux estimation*. Boundary-layer Meteorology, 145 (1), 27-44.
- Snyder, R.L. Orang, M., Bali, K. Eching, S. and Zaccaria, D., 2016. *The Basic Irrigation Scheduling Manual*. http://biomet.ucdavis.edu/irrigation_scheduling/bis/BIS.pdf
- Spiegel-Roy, P., Mazigh, D. and Evenari, M., 1977. *Response of pistachio to low soil moisture conditions*. Journal American Society of Horticultural Science, 102, pp. 470-473.
- State Water Board. *Information on Senate Bill 88 and Emergency Regulation for Measuring and Reporting the Diversion of Water*. California Water Boards, State Water Resources Control Board. 21 Mar. 2016.
www.waterboards.ca.gov/waterrights/water_issues/programs/measurement_regulation. Accessed 12 Feb. 2018.
- State Water Board. *Title 23 of California Code of Regulations. Waters, Division 2. Department of Water Resources, Chapter 1.5. Groundwater Management, Subchapter 2. Groundwater Sustainability Plans*.
www.water.ca.gov/groundwater/sgm/pdfs/GSP_Emergency_Regulations.pdf. Accessed 12 Feb. 2018.
- Teviotdale, B.L., Goldhamer, D.A. and Viveros, M., 2001. *Effects of deficit irrigation on hull rot disease of almond trees caused by Monilinia fructicola and Rhizopus stolonifer*. Plant Dis. 85(4):399-403.
- Tindula, G.N., Orang, M.N. and Snyder R.L., 2013. *Survey of Irrigation Methods in California in 2010*. J. Irrig. Drain Eng. 139 : 233-238.
- Torreillas A., Alarcon J.J., Domingo R., Planes J. and Sanchez-Blanco M.J., 1996. *Strategies for drought resistance in leaves of two almond cultivars*. Plant Science 118:135-143.
- University of California Division of Agricultural and Natural Resources. *Drought management tip sheets*. ciwr.ucanr.edu/california_drought_expertise/droughttips. Accessed 12 Feb. 2018.
- United States Department of Agriculture. *County Ag Commissioners' Data Listing: Crop Year 2016*. www.nass.usda.gov/Statistics_by_State/California/Publications/AgComm/Detail/. USDA's National Agricultural Statistics Service California Field Office. Accessed 18 Feb. 2018.
- U.S. Environmental Protection Agency. *Water-Energy Connection*.
www.epa.gov/region9/waterinfrastructure/waterenergy.html. Accessed 12 Feb. 2018.
- U.S. Geological Survey. *California Water Science Center: 2012-2016 California Drought: Historical Perspective*. ca.water.usgs.gov/california-drought/california-drought-comparisons.html. Accessed 12 Feb. 2018.
- Zaccaria, D., Marino, G., Whiting, M.L., Ferguson, L.E., Snyder, R., Sanden, B., Lampinen, B., Grattan, S., Jin, Y., Ustin, S.L., Kent, E., Bali, K., and Culumber, C. *et al.*, 2017 *Determination of soil-plant-water dynamics of mature pistachio orchards grown under saline onditions*. Preliminary results file to the California Pistachio Research Board, 2 pp.

APPENDICES

These appendices are published under separate cover CEC-500-2019-022-APA-D.

Appendix A: Life Cycle Assessment Model for Water Measurement

Appendix B: Life Cycle Assessment Protocol for Optimized Irrigation Scheduling

Appendix C: Rational Irrigation Schedules

Appendix D: Partial Irrigation Scheduling