



**CALIFORNIA
ENERGY COMMISSION**



**CALIFORNIA
natural
resources
AGENCY**

Energy Research and Development Division

FINAL PROJECT REPORT

Unlocking Industrial Energy Efficiency Through Optimized Energy Management Systems

Gavin Newsom, Governor
December 2019 | CEC-500-2019-060

PREPARED BY:

Primary Authors:

Michael Greenstone, Co-Principal Investigator
Christopher Knittel, Co-Principal Investigator
Catherine Wolfram, Principal Investigator
Andrew Campbell, Project Manager
Karen Notsund, Associate Director
Kathy Nagel, Program Manager

Energy Institute at Haas, Haas School of Business, UC Berkeley
247 University Hall
Berkeley, CA 94720-5180
(510) 642-9590
ei.haas.berkeley.edu

Contract Number: EPC-14-075

PREPARED FOR:

California Energy Commission

Michael Lozano
Project Manager

Virginia Lew
Office Manager
ENERGY EFFICIENCY RESEARCH OFFICE

Laurie ten Hope
Deputy Director
ENERGY RESEARCH AND DEVELOPMENT DIVISION

Drew Bohan
Executive Director

DISCLAIMER

This report was prepared as the result of work sponsored by the California Energy Commission. It does not necessarily represent the views of the Energy Commission, its employees or the State of California. The Energy Commission, the State of California, its employees, contractors and subcontractors make no warranty, express or implied, and assume no legal liability for the information in this report; nor does any party represent that the uses of this information will not infringe upon privately owned rights. This report has not been approved or disapproved by the California Energy Commission nor has the California Energy Commission passed upon the accuracy or adequacy of the information in this report.

PREFACE

The California Energy Commission's Energy Research and Development Division supports energy research and development programs to spur innovation in energy efficiency, renewable energy and advanced clean generation, energy-related environmental protection, energy transmission and distribution and transportation.

In 2012, the Electric Program Investment Charge (EPIC) was established by the California Public Utilities Commission to fund public investments in research to create and advance new energy solutions, foster regional innovation and bring ideas from the lab to the marketplace. The California Energy Commission and the state's three largest investor-owned utilities—Pacific Gas and Electric Company, San Diego Gas & Electric Company and Southern California Edison Company—were selected to administer the EPIC funds and advance novel technologies, tools, and strategies that provide benefits to their electric ratepayers.

The Energy Commission is committed to ensuring public participation in its research and development programs that promote greater reliability, lower costs, and increase safety for the California electric ratepayer and include:

- Providing societal benefits.
- Reducing greenhouse gas emission in the electricity sector at the lowest possible cost.
- Supporting California's loading order to meet energy needs first with energy efficiency and demand response, next with renewable energy (distributed generation and utility scale), and finally with clean, conventional electricity supply.
- Supporting low-emission vehicles and transportation.
- Providing economic development.
- Using ratepayer funds efficiently.

Unlocking Industrial Energy Efficiency Through Optimized Energy Management Systems is the final report for the Unlocking Industrial Energy Efficiency Through Optimized Energy Management Systems project (Contract Number EPC-14-075) the University of California Berkeley. The information from this project contributes to the Energy Research and Development Division's EPIC Program.

For more information about the Energy Research and Development Division, please visit the [Energy Commission's website](http://www.energy.ca.gov/research/) (www.energy.ca.gov/research/) or contact the Energy Commission at 916-327-1551.

ABSTRACT

The industrial sector in California is a significant part of the economy, accounting for almost 11 percent of total gross state product. Historically, industrial facilities have paid little attention to electricity consumption, despite consuming around 25 percent of total energy consumption in 2017. Moreover, publicly funded energy efficiency measures have focused mainly on residential and commercial customers. The E2e Project—a joint research initiative of the University of California, Berkeley; the Massachusetts Institute of Technology; and the University of Chicago—used a precommercial industrial energy management system developed by Lightapp, Inc., which has an office in San Mateo, California, to optimize the energy use of compressed air systems. The Lightapp energy management system collected and analyzed data from sensors placed at key locations within the manufacturing process at 102 industrial facilities. The EMS provided real-time data to facility personnel and customized recommendations on how to reduce energy use and optimize equipment performance. Annualized energy cost savings are estimated to be \$812,000, and greenhouse gas reductions estimated to be 1,500 tons for the facilities analyzed. The industrial customer demand for this type of software-based EMS was high, with 22 percent of all eligible sites agreeing to join the project and 41 percent of all project participants opting to subscribe to the EMS services after the end of the project. If applied to compressed air systems across Southern California Edison and Pacific Gas and Electric’s industrial sectors, investor-owned utility ratepayers could save \$16 million annually.

Keywords: Business growth, commercialization, energy efficiency, energy management, innovation, manufacturing, R&D impact

Please use the following citation for this report:

Greenstone, Michael, et al. 2019. *Unlocking Industrial Energy Efficiency Through Optimized Energy Management Systems*. California Energy Commission. Publication Number: CEC-500-2019-060.

TABLE OF CONTENTS

	Page
PREFACE	i
ABSTRACT	ii
TABLE OF CONTENTS	iii
LIST OF FIGURES	v
LIST OF TABLES	vi
EXECUTIVE SUMMARY	1
Background.....	1
Project Purpose	1
Project Approach.....	2
Project Results	3
Technology/Knowledge Transfer/Market Adoption (Advancing the Research to Market).....	4
Benefits to California	4
CHAPTER 1: Project Background	7
Evaluation Method.....	9
Lightapp Software	9
CHAPTER 2: Targeting Facilities and Marketing Materials.....	11
Industrial Customer Information Procurement Process and Results	11
Pacific Gas and Electric and Southern California Edison	11
Data Request Process	11
Data Received	13
Publically Available Data	14
Industrial Customer Population Analysis.....	15
Industry Size.....	15
Industry Type	18
Additional Data.....	19
Marketing Materials	20
CHAPTER 3: Recruitment Process and Results	22
Recruitment Design.....	22

Recruitment Method	23
Recruitment Results	24
Facilities Recruited.....	25
Reason for Nonparticipation	27
Conclusions and Lessons Learned.....	29
CHAPTER 4: Installation and Baseline Data Collection	31
Pilot Installations.....	31
Pilot Method and Lessons Learned.....	31
Pilot Results	32
Mass Installations.....	33
Mass Installation Design	33
Mass Installation Results.....	36
Baseline Data Collection.....	36
Data Configuration and Connection	36
Baseline Performance Results.....	37
Conclusions and Next Steps	39
CHAPTER 5: Software Engagement Period.....	41
Roll-Out Method.....	41
Roll-Out Results	43
Initial Roll-Out of Lightapp Software and Services	43
Expansion of Lightapp Software and Services.....	44
Conclusions and Lessons Learned.....	45
CHAPTER 6: Data Analysis and Evaluation of Savings.....	47
Method.....	48
Data Aggregation	48
Regression Model	49
Analysis Constraints.....	50
Savings Analysis Preliminary Results.....	50
Conclusions and Lessons Learned.....	51
CHAPTER 7: Willingness to Pay	52
Implemented Design	52
Original Design	54

Results	55
Participant Take-up	55
Lightapp Pricing	55
Expansion of Lightapp Services	57
Impact on Widespread Commercialization	57
Conclusions and Lessons Learned.....	58
CHAPTER 8: Technology/Knowledge/Market Transfer Activities.....	60
Technology and Knowledge Transfer	60
Completed Outreach	60
Published Documents	61
Further Planned Outreach	61
Production Readiness and Market Transfer	62
Current Status.....	63
Implementation Plan	64
Scaling Up: Critical Processes and Lessons Learned	65
Conclusions and Lessons Learned.....	71
CHAPTER 9: Conclusions/Recommendations	72
Lessons Learned	72
Policy Development.....	73
CHAPTER 10: Benefits to Ratepayers	74
Quantitative and Qualitative Estimates of Benefits.....	74
REFERENCES	76
APPENDIX A: Project Marketing Materials	A-1
APPENDIX B: Statistical Models.....	B-1

LIST OF FIGURES

	Page
Figure 1: Average Monthly Bills (Full Sample, 2014)	17
Figure 2: Industry Size by Average Monthly Bill (Final Sample, 2014)	18
Figure 3: Recruitment Final Results	25

Figure 4: Map of Project Participants	26
Figure 5: Example Pilot Site CAS Score Over the Length of the Baseline Period (90 Days)	33
Figure 6: Installation Process	34
Figure 7: Baseline Performance of Mass Installation Sites	38
Figure 8: Lightapp Login Frequency and User Data	44
Figure 9: Willingness to Participate Process Flow.....	53
Figure 10: Lightapp Pricing at Purchased and Declined Sites.....	56
Figure 11: Development of the Lightapp Prototype Communication Device	66
Figure 12: The Lightapp Technology Stack	67
Figure 13: The Lightapp Integrated Messaging Dashboard	69

LIST OF TABLES

	Page
Table 1: Industry Type by North American Industry Classification System (Full and Final Sample)	19
Table 2. Baseline Pilot Site Performance Averages	32
Table 3. Mass Installation Timing Details	35
Table 4: Baseline Site Performance Averages.....	38
Table 5: Baseline Site Performance Averages by Industry	39
Table 6: Willingness to Pay Take-Up Results.....	55

EXECUTIVE SUMMARY

Background

According to the Center for Manufacturing Research, the industrial sector in California is a significant part of the economy, with a total manufacturing output of \$300.4 billion in 2017, or 10.9 percent of total gross state product. For energy, the industrial sector consumed 24.7 percent of California's total energy consumption in 2016 at a cost of more than \$13.8 billion. Historically, industrial plants have paid little attention to electricity consumption, focusing instead on other optimization efforts. Many industrial customers are unaware of energy conservation and energy efficiency opportunities, and it is rare to find energy management systems that use real-time, submeter-level data at industrial plants. These missed opportunities are pervasive in compressed air systems, which account for 8-12 percent of all industrial electricity consumption and are used in a wide variety of industrial sectors.

The E2e Project—a joint research initiative of the University of California, Berkeley; the Massachusetts Institute of Technology (MIT); and the University of Chicago—targeted this information gap by using a precommercial energy management system developed by Lightapp, Inc. that collects and analyzes data from sensors placed at key locations within the manufacturing processes. As an integral part of the program, E2e designed and implemented a rigorous evaluation method to measure the effect of this new technology on compressed air system electricity use at each site.

Project Purpose

The E2e Engage project addressed the barriers that prevent industrial customers from improving their energy efficiency while maintaining operation efficiency and competitiveness: resistance to change, technology gaps, and industry fragmentation and isolation. The project overcame resistance to change in several ways. Project participants were able to use an innovative energy management system at low or no cost, reducing risk and encouraging experimentation. The monitoring and analytical tool was well suited for industrial customers since it does not pose any operational risks to ongoing production processes. The project filled an important technology gap by bringing the benefits of declining communicating-sensor costs and cloud-based analytic tools to industry. These approaches have not historically been available at a reasonable cost. Because the team also focused on a common industrial system, compressed air, the project overcame the challenge of industry fragmentation and isolation. Participating customers were able to compare the efficiency of their compressed air systems to other factories in their industry and across multiple industries.

By overcoming these barriers, the project also identified new ways to reduce electricity use at a lower cost. These reduction strategies will reduce greenhouse gas emissions from the electric power sector, to help the state achieve its 2030 and 2050 greenhouse

gas (GHG) reduction goals established by Senate Bill 32 (Pavley, Chapter 429, Statutes of 2016) and Executive Order S-3-05.

Project Approach

The E2e Project brought together three principal investigators: Dr. Catherine Wolfram, University of California, Berkeley; Dr. Michael Greenstone, University of Chicago; and Dr. Christopher Knittel, Massachusetts Institute of Technology. The research team partnered with Lightapp, Inc., led by Elhay Farkash, CEO, and Guy Peer, COO. Ingersoll Rand was the primary installation partner for the widespread rollout. Members from the California Public Utilities Commission (CPUC), California Energy Commission (CEC), and California utilities participated in a technical advisory committee to provide feedback and input on the project.

As an integral part of the project, the E2e team designed and implemented a rigorous evaluation method using a randomized control trial. The project was broken into phases: recruitment, installation, baseline, treatment, and willingness to pay. After receiving and analyzing industrial customer data provided by Southern California Edison (SCE) and Pacific Gas and Electric (PG&E), the research team created a list of 1,124 industrial plants that were eligible for the project. These plants were placed in a random order and assigned to two groups: 70 percent of facilities were offered the Lightapp software at no cost, and 30 percent were offered the Lightapp software for a discounted monthly fee (75 percent of full price). The CEC grant paid for installation costs for all sites. For the recruitment phase, the names and locations of 14 factories were released weekly to the Lightapp team. Lightapp had 40 days to recruit as many of the 14 plants as possible into the project with the goal of recruiting 100 participants. After being recruited, participants entered the installation phase. The installation partner, Ingersoll Rand, and the Lightapp team worked with each facility to schedule site visits and installations.

After installation was completed at a site, the plant entered the 90-day baseline period. During this time, the Lightapp technology gathered data on electricity use and compressed air system flow and pressure, but the facility did not have access to these data or to the related reports. The data collected during this time established a “business-as-usual” profile. The combined baseline data from all participant sites served as the control group. After completing the baseline phase, a plant entered the treatment period. Facilities entered into the treatment phase in the same order as established in the initial randomized recruitment list. Entering sites into treatment in random order ensured that the evaluation remained unbiased because it did not allow either Lightapp or the facilities to time their participation strategically. When participants entered treatment, plant personnel were given logins to the Lightapp online platform, allowing them to view real-time data, run analytics, and compare site performance to their baseline and other, anonymized participating sites. The Lightapp team also provided customized reports and recommendations to each facility during treatment to encourage changes that could reduce energy usage, improve plant

performance, and decrease operational costs. Sites remained in treatment for 12 months, with all data stored by Lightapp during this time.

After the eleventh month of treatment, participants entered the final project stage, “willingness to pay.” Willingness-to-pay studies help determine the optimal price for a good or service and measure the market demand for a product. Participants were told the project was almost finished; however, they had the option of continuing to use the Lightapp energy management system for a subscription price. The Lightapp team generated quotes for the energy management system services for each site based on multiple factors, including number of users, data streams, and level of customization. Participants could elect to subscribe to the Lightapp service at the quoted price, pay to expand their services to include additional equipment, or decline and stop receiving the data and reports provided by Lightapp.

The experimental design was refined throughout the project period to address feedback from the technical advisory committee, implementation partners, and the participant sites. For example, a six-site pilot rollout was completed before the full-scale rollout, which led to many modifications to the design of recruitment and installation. Specifically, the recruitment responsibilities shifted from the installation partners to the Lightapp team based on the results of the pilot, and the marketing materials and strategy used to communicate with participant sites was adapted to better meet plant expectations and interests.

Project Results

The research team achieved the project goals and met the objectives. The team recruited 102 industrial plants (including the pilot sites) that used the Lightapp energy management system. For all facilities analyzed, the team estimated the annualized energy cost savings to be \$812,000. The recruitment and willingness-to-pay phases indicated a significant demand for a software platform to optimize energy use among industrial facilities, with 22 percent of all eligible facilities opting to join the project and, to date, 41 percent of project participants deciding to purchase the Lightapp energy management system services after the project close.

The research team also collected valuable lessons for taking an energy efficiency technology from a precommercial state to market-ready:

- Communications with participants should be simple and straightforward, avoiding jargon or buzzwords and focusing on the benefits of the technology.
- Scaling up from a pilot to full scale required the development of a standardized installation and rollout process as opposed to one customized to each site.
- Compressed air systems were good candidates for energy efficiency technology, but the Lightapp energy management system can integrate many other plant systems, such as production equipment, boilers, and chillers that can increase energy savings and reduce waste.

- Sites that received the Lightapp energy management system were twice as likely to agree to purchase the service as sites that had not received the technology.

Technology/Knowledge Transfer/Market Adoption (Advancing the Research to Market)

The team will disseminate the project results to multiple audiences, including regulators and policy makers such as the CEC and CPUC, California utilities, trade organizations, and academic journals. Blog posts, presentations at relevant conferences and summits, and articles in trade publications were completed, and additional outreach will continue after end of the project.

The lessons learned from the project have prepared Lightapp to move from precommercial technology into full-market commercialization. During the project, the market for Lightapp was limited to the selected industrial customers within the service territories of PG&E and SCE and only for their compressed air systems. The Lightapp energy management system will be marketed to many types of industrial and manufacturing plants and throughout California. Several systematic changes are planned based on the insights gained from the scale up from the pilot stage to the full-scale rollout.

- Scaling technology: New infrastructure development and architecture is planned for the anticipated influx of new users and data streams.
- Communication devices: Uniform, reliable hardware was the missing piece in project installations, and development of proprietary hardware is planned for future success.
- Scaling operations: As the Lightapp team grew during the Engage project, it was planned to continue growing as required by large-scale operations and engagement assurance.
- Market and pricing: New pricing structures were developed to meet customer needs in the continuously changing market to adapt for multisite customers and expansion beyond compressed air systems.

Benefits to California

For the plants used in the preliminary savings analysis, this total annual impact is:

- 6,292,000 kilowatt-hours (kWh)/year in reduced consumption
- \$812,000/year in lower bills
- 1,500 tons/year in GHG emissions.

Applying the results to the electricity used by all compressed air systems across California's industrial sector, investor-owned utility ratepayers could see annual savings of:

- 129,400,000 kWh

- \$16.5 million
- 30,700 tons of GHG emissions

In addition, while this study focused solely on compressed air, the methods used and the Lightapp technology can be applied to entire industrial systems. Many industrial sites expressed interest in expanding beyond compressed air after experiencing Lightapp's energy management system firsthand. Expanding the savings seen in this project to general industrial energy could save significantly more annually:

- 2,587,979,000 kWh
- \$329 million
- 614,300 tons of GHG emissions

The energy savings and operation efficiency that California industrial facilities gained through this project may encourage some plants to remain in the state, preventing further reductions in the customer base.

CHAPTER 1:

Project Background

The industrial sector in California is a significant part of the economy, with a total manufacturing output of \$300.4 billion in 2017, or 10.9 percent of total gross state product.¹ In terms of energy, the industrial sector consumed 24.7 percent of California's total energy consumption in 2016, a cost of over \$13.8 billion². Historically, industrial facilities paid little attention to electricity consumption, focusing instead on optimizing their raw material and supply chain practices. Many industrial customers were unaware of energy conservation and energy efficiency opportunities that could be low cost or no cost. Often the only electricity data available was at the whole facility level and could not be easily analyzed to find energy-saving opportunities. Process-level submetering was rare due to its historically high costs. Where submetering existed, it was typically not used to find ways to lower energy costs. Energy management systems that use real-time data and analysis to identify energy savings were not widespread in the market.

These problems are pervasive in compressed air systems. Accounting for 8-12 percent of all industrial electricity consumption, compressed air was used as a means of operating pneumatic systems and processes such as dusting and cooling. A typical system maintains its pressure, and when equipment uses the compressed air, the pressure in the system drops and the compressor kicks in to bring the system back up to its operating pressure. However, systems commonly have leaks and compressors are operated inefficiently. Since the amount of losses is not measured, a facility could not determine whether it is worth investing in energy savings projects to improve system performance.

The E2e Project, a joint research initiative of the University of California, Berkeley (UC Berkeley), the Massachusetts Institute of Technology, and the University of Chicago, deployed a pre-commercial energy management system (EMS) developed by Lightapp, Inc. The EMS collected and analyzed data from sensors placed at key locations within manufacturing processes. Data were correlated with the manufacturing inputs and outputs to identify performance anomalies and inefficiencies that could not be explained by changes in the facility's production. The E2e Engage team focused on compressed air systems due to their widespread use throughout multiple manufacturing sectors. As an integral part of the project, E2e designed and implemented a rigorous evaluation

¹ Center for Manufacturing Research. "California Manufacturing Facts." 2018.

² U.S. Energy Information Administration. "California State Profile and Energy Estimates." 2018

method to measure the impact of this new technology on electricity use at each facility site.

This project was the first large scale evaluation of an industrial energy efficiency program using a randomized control trial. The project revealed robust estimates of the energy savings and other benefits from using an energy management system, as well as estimated the take-up by different industries and what types of facilities are most willing to pay for the technology.

The goals of the project were to:

- Reduce the electricity used by compressed systems per unit of industrial output;
- Lower operating costs for industrial facilities; and
- Evaluate industrial customer demand for a software platform to optimize energy use.

The technology used had the potential to reduce the electricity costs of industrial customers. The Lightapp system delivers performance analysis and recommendations to industrial facilities, providing the opportunity to optimize their manufacturing processes with respect to electricity consumption and operational efficiency across multiple sectors. The project sought to identify industries in which an optimization technology could result in cost effective energy savings, and lead to its commercialization. Commercialization of an effective energy optimization technology could result in a significant number of industrial customers using this technology to lower their electricity costs, resulting in ratepayer benefits.

The project technology could also lead to technological advancement and breakthroughs to achieve the State of California's statutory energy goals by addressing two barriers to improving energy efficiency in the industrial sector. First, the project overcame industrial customers' resistance to change by providing a low or no cost opportunity to experiment with an innovative energy management system. Second, the project filled a technology gap by bringing the benefits of falling sensor and communications costs and cloud-based analytic tools to industry.

The objectives of this project were to:

- Recruit 100 industrial facilities to use an optimized energy management system and install meters and communications devices.
- Estimate electricity and operating cost savings that result in customer actions based on analytics and recommendations produced by the optimized energy management system.
- Estimate customers' willingness to pay for an optimized energy management system.

Evaluation Method

Among impact evaluation methodologies, randomized control trials (RCTs) are the gold standard due to their ability to produce unbiased results. By measuring the outcomes across two statistically identical groups – some having participated in the program, some not – RCTs are able to determine what would have happened to the outcome of interest in the absence of the program, known as the counterfactual. Because program participation is random across the two identical groups, any difference in outcomes between groups could be attributed solely to the program.

Because participation was voluntary, this could produce biased results if facilities that opted into the project were systematically different from facilities that did not opt into the project. These two groups would be statistically dissimilar and the counterfactual would no longer be a viable representation of what would have happened to facilities' energy consumption had they not opted into the project. Consequently, this project adopted a randomized rollout (also known as randomized phase-in) evaluation design, focused on encouragement. Participants are assigned randomly to groups that received different levels of incentives to impact program take-up and level of participation.

In a randomized rollout design, participants are enrolled into a program in randomized order over time. Those who were waiting to enroll in the program serve as the counterfactual (also known as the control group) for those enrolled in the program (also known as the treatment group). For this project, this meant that recruited facilities installed the necessary equipment and completed a baseline period of at least three months during which time compressor-level data were collected, but the facility did not have access to the energy management system or its data. The combined baseline data from all 100 participating facilities represented the control group. Upon completing their baseline period, each facility had 12 months of access to Lightapp's energy management software.

For the results of the evaluation to remain unbiased, it was imperative that facilities receive access to Lightapp's analytics in randomized order. If left to decide when to begin managing energy consumption, facilities could strategically time their participation in accordance with their expected pattern of energy use. The recruitment design revolved around the adherence to this requirement. All other features of recruitment were designed so Lightapp had ample time to recruit facilities, the install partners had sufficient time to install the equipment, and the project finished within the time allotted by the CEC.

Lightapp Software

The Lightapp energy management system is a cloud-based Industrial Internet of Things application that delivers insight into the physical operation of industrial facilities, illuminating opportunities for efficiency gains and reduced energy consumption in real-

time. Lightapp identifies and quantifies energy and operational inefficiencies, facilitating change management throughout industrial organizations.

The application could be customized to display different data streams in varying widget formats according to the priorities of individual users within a facility. The principal data stream illustrated energy consumption per unit of output. For this project, this equated to compressed air electricity per unit of industrial output. However, the Lightapp energy management system was also applicable to other energy sources, such as natural gas, water, and fuel oil. Some of the key features of the Lightapp system are:

- **Mapping:** Industrial customer setup in the Lightapp system begins with mapping. This online page represents the map of a typical compressed air system, including equipment specification fields. When a customer began to optimize, the compressed air demand is also mapped.
- **Energy Dashboard:** Although it was highly customizable to meet users' preferences, this dashboard displayed hourly compressed air electricity usage and costs, disaggregated by rate over the course of one week.
- **Air compressor performance:** This data stream was real-time compressed air performance over the course of one week. Data included electricity usage, pressure, flow, efficiency, cost, a compressed air benchmark established by the user, and the performance of the compressed air system relative to the benchmark.
- **Production KPI:** This was an example of the principal data stream in the Lightapp energy management system: energy consumed per industrial output. Other data streams incorporated electricity consumption and production data to measure plant performance and quantify electricity cost and savings.

The average Lightapp user was expected to spend 15 minutes per day on the application, plus a monthly meeting with the facility's energy team to discuss energy trends and steps for improvement. The Lightapp energy management system was an enabler: it revealed inefficiencies and enabled the customer to take corrective action – it did not correct the inefficiency automatically. During the first three to six months of access to the Lightapp dashboard, users were guided through system tutorials and recommended to perform a standardized compressed air optimization process that included simple steps such as finding and eliminating leaks and installing compressed air boosters. Users then received comprehensive data analysis support that was personalized to the operation of each facility. Lightapp worked closely with the energy team to analyze data, identify inefficiencies, and recommend corrective action.

CHAPTER 2:

Targeting Facilities and Marketing Materials

The E2e team required at least 100 qualified industrial facilities to join the project to ensure that the statistically significant energy savings could be measured. The first step was to obtain and sort the data needed to identify facilities that might have large compressed air systems that would benefit from using the Lightapp software. The project team approached two California utilities, Pacific Gas and Electric (PG&E) and Southern California Edison (SCE), to start the information procurement process.

Industrial Customer Information Procurement Process and Results

Pacific Gas and Electric and Southern California Edison

The request for detailed industrial customer information was driven by the needs of the project to identify the industrial customer population in its entirety and to quantify the impact of the optimized energy management system on energy usage with econometric methods. It was essential to the design of the research to collect this information from an objective source to achieve unbiased results. Acquiring this information directly from the utilities allowed the project to create a pool of potential participants that closely resembles the prospective market for an industrial energy management system. Given 15-minute interval electricity usage data, utility data provided for robust econometric analysis that cannot be found in other data sources.

The Energy Institute at the Haas School of Business at UC Berkeley, a partner in the E2e Project, has cultivated data sharing relationships with PG&E and SCE. The Energy Institute has a perfect record of data stewardship and these collaborations have been the source of dozens of research projects. All data obtained under non-disclosure agreements or otherwise recognized as confidential are stored on a secure, locked server accessible only to Energy Institute staff assigned to this specific project. Whenever possible, personally identifiable information was anonymized and never printed. Only figures and tables of summary statistics are taken off the server – never information about individual firms. Once a project is completed, the data are permanently destroyed.

Data Request Process

Starting in March 2015, E2e worked closely with both utilities to develop and complete the data request process. It was vital that the utilities understood E2e's research objectives to provide the relevant variables. For example, the project targeted industrial facilities, which equate to street addresses in the data. Each address may be associated with multiple service accounts and service points, so E2e worked meticulously with each

utility to discover how the available variables aggregated into one industrial facility. Furthermore, the utilities explained that the variables of interest reside in different databases. Amassing 15-minute interval data and merging it with service account information is an extensive process that each utility sought to minimize.

Like previous data requests, E2e put in place a non-disclosure agreement for researchers that will potentially view the data and reviewed data security measures with the utilities. Unlike previous data requests, this process involved conversations surrounding this project's customer recruitment process. Utilities wanted to ensure quality customer service when industrial customers are approached and recruited to participate in the project. E2e then communicated to the utilities the details and objectives of the recruitment process, as well as the specific messages that customers will receive. To finalize the data request, E2e agreed to share the project's marketing materials with the utilities, revise those materials according to customer feedback received via the utility, and provide background information and training for utility account managers whose customers might ask about the project.

During the data request process, E2e learned that the utilities' databases do not have an industrial classification assigned to service accounts. Compressed air users were also unidentifiable in the utility data. E2e then worked with both utilities and Lightapp to identify a list of North American Industrial Classification System (NAICS) codes that could be regarded as industrial and are likely to have compressed air. NAICS are six digit codes used by Federal statistical agencies to classify business establishments for the purpose of collecting, analyzing, and publishing statistical data related to the U.S. business economy. Six digit NAICS are the most specific description of business type, though NAICS are commonly divided into sectors according to their first two digits. Data was requested for the following NAICS:

- 112 (Animal production and aquaculture)
- 21 (Mining, quarrying, and oil and gas extraction)
- 2213 (Water, sewage and other systems)
- 237 (Heavy and civil engineering construction)
- 31-33 (Manufacturing)
- 48 (Transportation)
- 493 (Warehousing and storage)
- 562 (Waste management and remediation)

Facility-level NAICS are not always identical to their corporate-level NAICS. Hence, E2e requested industrial customer data for service accounts that are associated with these NAICS at any level. To account for missing data, E2e also requested data for industrial facilities without assigned NAICS codes.

To be eligible to participate in the project, industrial customers must have been a large consumer of electricity and had a compressed air system. To focus on medium and

large scale electricity consumers, data was requested for industrial facilities that have an average combined electricity and natural gas bill of at least \$10,000 per month in 2014. Data was requested at the service agreement level with keys to allow for aggregation. For the period beginning January 1, 2010 to present, the following variables were requested:

- Service account ID (SA_ID)
- Account ID (ACCT_ID)
- Premise ID (PREM_ID)
- Name and facility address associated with each Premise ID
- NAICS 1 – account level
- NAICS 2 – facility level
- By SA_ID, electricity and natural gas bills in dollars
- Electricity usage in kWhs by billing period or fifteen minute usage if available
- Maximum demand (kW), peak demand, and partial peak demand in each month, if collected for rate
- Natural gas usage in mmBtu by billing period or daily usage if available
- Applicable tariff and rate schedule
- Participation in peak day pricing
- Beginning and ending billing dates
- Whether a customer is a Direct Access or Community Choice Aggregation customer
- Program participation in industrial energy efficiency programs
- Results of recent compressed air audits, if applicable
- Program participation in demand response programs
- Available self-generation information on each customer, such as Rule 21 registration

Once the data requests were fully executed, California Public Utilities Commission policy mandated E2e to wait 30 days before receiving the data. Data were received from PG&E on December 14, 2015 and from SCE on February 16, 2015.

Data Received

The data files received were grouped according to service agreement demographic information, participation in energy efficiency programs, participation in demand response programs, and 15-minute interval data. The amount of PG&E's interval data varied across service accounts, but spanned from January 1, 2010 to September 30, 2015 with an average of 1,087 days (about three years) of data. On the other hand, SCE provided interval data from April 1, 2014 to December 31, 2015 with the option of

delivering three more years. Over 90 percent of SCE's service points had full histories of interval data spanning this period and the remainder had an average of 420 days.

After controlling for differences in variables names, the received data varied only slightly between the two utilities. PG&E provided an indicator of natural gas usage, whereas SCE provided variables for monthly kilowatt usage, maximum monthly kilowatt usage, monthly bill amounts, and number of billing days per month. The variables received from both utilities were:

- Service account ID
- Account ID
- Premise ID
- Customer name
- Service street address, city, and zip code
- NAICS – facility level
- Rate schedule
- Average monthly bill for 2014
- Indicators for Direct Access, Community Choice Aggregation, and net metering
- Participation in energy efficiency programs
- Participation in demand response programs
- 15-minute interval electricity usage

Publicly Available Data

Simultaneous with the data request process, E2e sought publicly available data sources to supplement potential utility data shortcomings. E2e pulled industrial customer data from two publicly available data sources:

1. Mergent Intellect: Mergent Intellect provides basic company facts on more than 20 million North American companies and over 70 million global companies. This database provides essentially the same information as Hoovers Online, combining Hoovers with Dun & Bradstreet with additional downloading capabilities. This database is available through the Massachusetts Institute of Technology library. Variables include company name and address, NAICS, parent company name, mailing address, and annual sales.
2. Pressure Vessel Registration: The State of California Department of Industrial Relations (CADIR) requires air tanks, liquefied petroleum gas propane storage tanks over 125 gallons, and high pressure boilers over 15 pounds per square inch gauge steam to register for and obtain a permit for operation. The database is available on the CADIR website and includes variables on the registered pressure vessel such as the year it was built, manufacturer, diameter, maximum

allowable pressure, and the company name and address where the tank is permitted to operate.

E2e determined the Mergent Intellect database was insufficient to identify potential participants for two reasons. First, the project targets medium and large industrial energy consumers. The only continuous variable that speaks to customer size in the Mergent Intellect data is annual sales. However, annual sales cannot be correlated with energy consumption accurately enough to credibly target medium and large industrial customers.

Second, the Mergent Intellect database was outdated and includes industrial customers no longer doing business. For example, pulling industrial customers in PG&E's service territory by the selected NAICS and above an annual sales threshold of \$800,000 yielded nearly 20,000 companies, far more than the PG&E data. The same data pull for SCE's service territory yielded approximately 14,000 companies.

E2e used the CADIR database to identify compressed air users in the utility data. To check the quality of the CADIR data, E2e consulted with implementation partners CDA Systems and Osterbauer Compressor Service and compared a random subset of companies in the utility data but not found in the CADIR data. Many of these randomly selected companies were confirmed to have compressed air; some were active customers of the implementers. Due to potential imprecision in the CADIR data, the project did not eliminate companies from the final sample of potential participants that are in the utility data, but not found in the CADIR data. Instead, E2e will weigh the likelihood of companies having compressed air heavier for those found in both datasets. The resulting sample was randomly selected, though companies matched in both datasets were more likely to be randomly selected than companies found only in the utility data.

Neither the Mergent Intellect nor the CADIR databases included energy consumption. Both public datasets also suffered from missing or erroneous data. For example, spelling errors made it difficult to search the data and both datasets included companies that are permanently closed. In terms of identifying the true, active industrial sector in California and each facility's energy consumption, E2e did not identify a dataset better than the data acquired directly from the utilities.

Industrial Customer Population Analysis

Industry Size

The customer information data files from PG&E and SCE contained 5,316 and 4,561 rows of data, respectively. As per E2e's request, each utility provided data at the contract level – service agreement for PG&E, service account for SCE. However, the project targeted industrial facilities as a whole, identified by a unique company name and a street address given for a service point, termed one unit of treatment. Given that there could be many contracts and service points for one industrial facility, raw data

had to be mapped and aggregated into individual units of treatment. The resulting sample size is 5,688 units of treatment.

Two constraints determined the minimum average monthly electricity bill for facilities to be included in the final sample: 1) the project must target energy consumers large enough for the Lightapp energy management system to appear cost-effective and 2) the project must target enough facilities to meet the objective of 100 installations. Assuming the customer improved the performance of their compressed air system by 20 percent and compressed air represents 10 percent of electricity costs, incorporating the cost of Lightapp reveals that \$40,000 was the lowest monthly electricity bill a customer can generate before the technology is cost-ineffective.

Controlling for one site per company location and drawing the minimum monthly eligibility threshold at \$40,000, the resulting sample size is 1,020 units of treatment – 488 from PG&E and 532 from SCE. These 1,020 were the project's final sample of potential participants to randomize.

In addition to 15-minute interval data, both utilities provided variables for average monthly electricity bills. The distribution of electricity consumption was right-skewed: a small number of extremely large electricity consumers inflated the average of this variable, so the median was a better descriptor of the variable. The median of the average monthly electricity bill variable was \$20,785 for the full sample of 5,688 units of treatment and \$64,979 for the final sample of 1,020. Annually, this amounted to an average of \$3.02 billion and \$1.26 billion in utility revenue for the full and final sample, respectively. Among the full sample, the 99th percentile began at \$400,809 with the largest consumers having monthly bills up to \$2 million. With the exception of the 99th percentile, the distribution of these units of treatment and the \$40,000 minimum bill threshold is illustrated in Figure 1.

Figure 1: Average Monthly Bills (Full Sample, 2014)

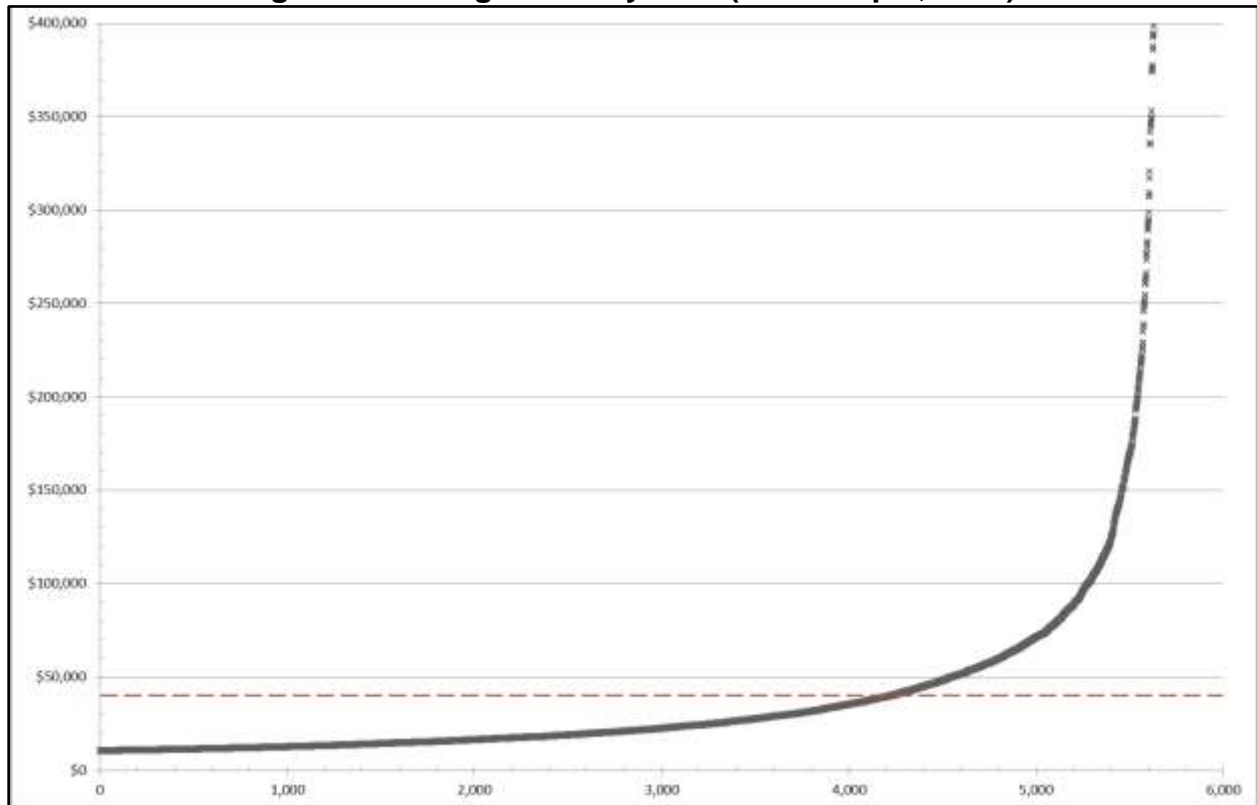

The distribution of industrial facilities average monthly bill values (units of treatment) is shown, with the red, dashed line indicating the \$40,000 minimum bill threshold used to select industrial customers qualified to participate in the Engage Project

Source: UC Berkeley

Applying the minimum bill threshold at \$40,000 eliminated 4,247 facilities from the sample, or about 75 percent of the full sample. After restricting to one site per company location in the sample and removing the pilot facilities, the final sample was 1,124 facilities. Figure 2 categorizes the final sample's average monthly electricity bill into bins of either \$10,000 or \$100,000, depending on the size of the customer. Final sample customers with average monthly bills less than \$100,000 are grouped into bins of \$10,000; customers with average monthly bills of \$100,000 or more are grouped into bins of \$100,000. For example, there are 254 facilities in the final sample with average monthly bills that range from \$40,000 up to but not including, \$50,000.

Figure 2: Industry Size by Average Monthly Bill (Final Sample, 2014)

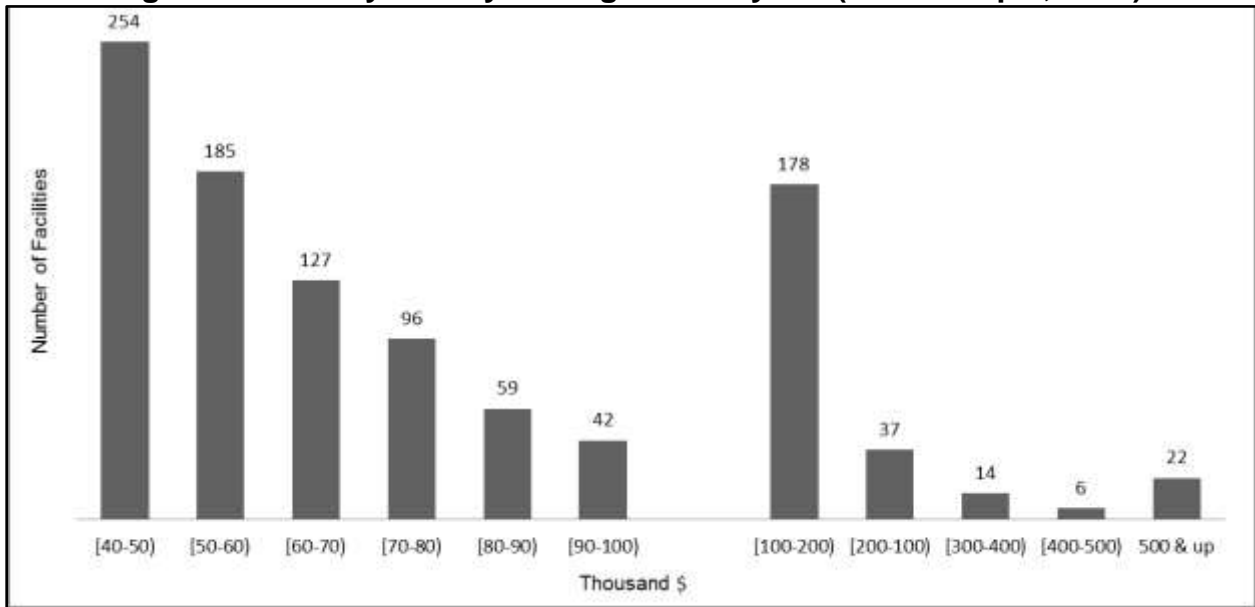

The final sample for the Engage project contained 1,020 facilities, shown above binned by customer size.

Source: UC Berkeley

Industry Type

For this analysis, industry type was defined by facility-level NAICS codes. E2e received industrial customer data if either the facility or the corporate-level NAICS were associated with the NAICS listed in the data request. For this reason, some facility-level service accounts in the received data have NAICS designations that were not requested because their corporate-level NAICS met E2e's requirement. E2e's data request included NAICS series beginning with two or three digits to target specific industrial segments expected to have compressed air. Given the received data, it was unclear whether the utilities have the capability to pull data according to three-digit NAICS. For example, E2e requested Heavy and Civil Engineering Construction (237xxx), but received data for the entire 23xxxx NAICS series (Construction).

The majority of the 5,688 units of treatment were manufacturing facilities (58 percent). Manufacturers were even more concentrated in the final sample (72 percent). Table 1 shows the complete list of received NAICS and their proportion of the full and final samples. Also in Table 1 are the results from transitioning from the full sample to the final sample. This column represents the percentage change in proportion of the sample after applying a \$40,000 minimum average monthly electricity bill threshold and using the CADIR database to select one site per firm. For example, utilities made up roughly 18 percent of the full sample of 5,688 units of treatment, but only 9 percent of the final sample – a 50 percent decrease.

Table 1: Industry Type by North American Industry Classification System (Full and Final Sample)

NAICS Series	NAICS Description	Facilities (Full)	Facilities (Final)	% Change
11	Agriculture, forestry, fishing and hunting	231	15	-63.8
21	Mining, quarrying, oil and gas extraction	266	54	13.2
22	Utilities	1,003	94	-47.7
23	Construction	17	*	*
31-33	Manufacturing	3,296	737	24.7
42-44	Wholesale and retail trade	57	6	-41.3
48	Transportation	235	37	-12.2
49	Warehousing and storage	260	37	-20.6
51-55	Finance, real estate, and management	207	26	-30.0
56	Waste management and remediation	74	11	-17.1

* Excluded due to small number of observations

The units of treatment selected for the final sample differ in proportion from the full sample, with manufacturing and mining, quarrying, and oil and gas extraction sites showing an increase in the final sample while all other categories decrease.

Source: UC Berkeley

Consistent with the final sample as a whole, manufacturing represented almost three quarters of the largest 5 percent of electricity bills. Among these customers, the next largest sector was mining, quarrying, and oil and gas extraction (14 percent).

Examining the six-digit NAICS codes of the largest manufacturers reveals that they are often related to the oil and gas industry. For example, NAICS 32xxxx is classified as manufacturing, but NAICS 324110 is defined as petroleum refineries.

Additional Data

E2e requested and received variables to test ancillary hypotheses on the effects of utilizing an optimized energy management system. Other variables, such as net metering, were requested because of the possible implications to measuring energy consumption. These additional variables are participation in energy efficiency programs,

participation in demand response programs, net metering, and direct access (DA) and Community Choice Aggregation (CCA).

Obtaining variables that indicate if an industrial customer generates their own electricity was imperative to accurately measure results. Not only will customers that self-generate electricity appear to have lower monthly utility bills, but participants could use the Lightapp energy management system in concert with their own electricity generation to optimize compressed air supply, diluting the results. If customers were selling electricity back to the utility, they can be identified in the data with a net metering indicator. Only 4 percent of the full sample had net metering capabilities. Of those that have net metering capabilities, two thirds are PG&E customers. Among the final sample, just 60 of the 1,124 facilities indicated net metering.

DA is a service that allows customers to purchase their electricity from a competitive energy service provider, but continue to receive that electricity using PG&E or SCE transmission and distribution systems. CCA is a program that allows governmental jurisdictions to purchase or generate electricity and sell the electricity to customers within its boundaries. Like DA, CCA customers still utilize PG&E's or SCE's transmission and distribution systems. Similar to net metering, identifying DA and CCA customers was essential to accurate results. Since these customers did not purchase their electricity from PG&E or SCE, their total monthly electricity costs were unknown to E2e. Whereas the proportion of DA customers was evenly distributed across utilities, PG&E had far more CCA customers than SCE. Approximately 10 percent of the full sample had DA service; 15 percent of the final sample. Of these additional data, CCA was the only variable that decreases from the full to the final sample. About 4 percent of PG&E's full sample was enrolled in CCA, but for SCE the figure is less than 1 percent. In the final sample, just over 1 percent were CCA customers.

Marketing Materials

The project developed marketing materials in an effort to standardize the recruitment process and familiarize the field implementers with marketing an optimized energy management system. The recruitment process began with a phone call, included up to three face-to-face meetings, and ended with the customer participation agreement. Constraining customers to a highly standardized recruitment process was not representative of a real world marketing strategy, but necessary to maintain the integrity of the research design. Therefore, the following marketing materials were used at varying times throughout the recruitment process at the discretion of the implementers:

- Talking points: A list of selling points and conversation starters to be used during the initial phone call. This includes an opening line, eligibility screening, project description, and questions customized according to personnel roles in the facility (e.g., facility manager, engineer, utilities manager, Chief Operation Officer, and Chief Financial Officer).

- Frequently asked questions: A list of possible questions with scripted answers that implementers expect to encounter. These will be used throughout the entire recruitment process, but a more succinct version is included on the project website.
- Email: An email sent immediately after the initial phone call. This reiterates the project benefits and includes a link to the project website.
- Voicemail: A scripted voicemail in case implementers cannot make contact when they attempt their initial phone call. After initial contact is made, implementers are not restricted to scripted voicemails.
- Website: A website that describes the project and its benefits. This includes the video and FAQs.
- Video: A video that describes the project and its benefits. It lasts two minutes forty seconds and will be available to view on the project website. The video script is included in Appendix 1.
- Presentation: A PowerPoint to use during face-to-face meetings with customers to describes the project and its benefits. This presentation includes more detail on the Lightapp energy management system than other items in the recruitment kit.
- Brochure: A one-page document describing the project and its benefits that will be handed to customers during the first face-to-face meeting.
- Participation agreement: A document outlining the customers' requirements for participation and the deliverables of the project. A customer confirms their participation in the project by signing this document.
- Survey questions: A short survey given to all approached customers to collect qualitative data and understand why customers did or did not elect to participate in the project. Customers that opt into the project will be given the same survey midway through and at the end of the project to identify behavior changes.
- Account manager handout: A one-page document describing the project to inform industrial customer account managers at PG&E and SCE. Should industrial customers contact their utility account manager and ask about the project, this document will inform the account managers so they can validate the project.

The written marketing materials are in Appendix A. The website and video are at the project website engage.lightapp.com.

CHAPTER 3:

Recruitment Process and Results

The recruitment process was designed to meet the requirements of a rigorous evaluation methodology while recognizing real-world marketing circumstances. The project rollout was designed to replicate real-world marketing strategies of SaaS (software as a service) products to industrial customers as closely as possible, while maintaining the integrity of a randomized control trial and completing the project within the time allotted by the CEC agreement.

Recruitment Design

As described in detail in Chapter 2, E2e constructed a list of potential participants using industrial customer data from two California utilities, PG&E and SCE. This data was organized and sorted to identify a sample of 1,124 facilities that met the target criteria. Assuming the customer improved the performance of their compressed air system by 20 percent and compressed air represents 10 percent of electricity costs, incorporating the cost of Lightapp revealed that \$40,000 was the lowest monthly electricity bill a customer could generate before the technology was cost-ineffective.

Industrial customers must also have compressed air systems large enough for Lightapp to be cost-effective. E2e and Lightapp's engineers determined that the project should target systems with a capacity of approximately 200 horsepower (HP) or larger. Therefore, a facility must have at least two compressors of 100HP each or three compressors of 60HP each to be eligible to participate.

The final sample of 1,124 facilities was then randomized, creating a list of target facilities for Lightapp to sequentially recruit into the project. In randomized order, 14³ facility names and addresses were released to Lightapp on a weekly basis. From the day of release, each facility was given 40 days to agree to participate. A signed participation agreement (see Appendix) signaled a successfully recruited facility. Because facility names were released to Lightapp every week and given 40 days to recruit, Lightapp maintained a stock of at least 70 facility names (five weekly releases) on any given day, all at different stages of recruitment.

³ Early recruitment results showed that water supply, irrigation, and sewage treatment facilities rarely utilize industrial compressed air systems and are thus ineligible to participate. Because these facilities make up 9.4 percent of the sample, E2e decided to increase the number of facility names released to Lightapp proportional to the number of water supply, irrigation, and sewage facilities present in a given week. For example, Lightapp would receive 17 facility names in a weekly release that contained three sewage treatment facilities.

The 40-day recruitment and 120-day installation windows addressed both research requirements and marketing practicalities. Without the deadlines, maintaining the randomized rollout could have resulted in the project lasting many years. For example, many facilities showed interest in the project, but asked Lightapp to “come back next year” when they expected to be less busy. Because facilities were granted access to Lightapp in randomized order, the project could not accommodate these facilities. These facilities would have delayed treatment to facilities later in the randomized order, delaying the project as a whole. The length of the recruitment and installation windows balanced the time needed for Lightapp to recruit a facility and accommodate the facility’s individual approval process and need for flexibility in scheduling their installation, all while adhering to the requirements of the randomized rollout.

Lastly, recruitment was designed to last roughly one year. The analysis has twelve months of data from each facility with access to Lightapp, but only three months of data from each facility constructing the control group. It was important for the analysis to have control group data spread throughout the year to capture seasonal variation in energy consumption.

Recruitment Method

The evaluation demanded that Lightapp standardize their recruitment method for the project. The research could not consistently measure the demand for an industrial energy management system if facilities were faced with varying recruitment methods from Lightapp. Therefore, all facilities underwent a similar recruitment method.

The data given to Lightapp contained facility names and addresses only – no contact information was available in the data. Lightapp needed to identify the appropriate decision maker in a facility. This could be particularly difficult. For example, most facilities had a plant manager and a maintenance manager; depending on company policy, either of these people could have the authority to enroll the facility in the project. Some facilities had to seek approval from a separate corporate office. Lightapp spent a substantial amount of time searching company websites and LinkedIn for points of contact.

After releasing the facility names, the first step in Lightapp’s recruitment method was to profile each facility. Lightapp needed to determine what each company does and if they are still operational. The utility data were not always up to date; sometimes the targeted facility had closed or had merged with or been bought by another company. Lightapp was also on the lookout for a company’s interest in energy efficiency measures, energy management, or sustainability. If a company had energy goals, Lightapp marketed their product as a means to meet those goals. Lastly, it was important to note the size company. If it was a large company with many locations nation- or worldwide, Lightapp expected a more bureaucratic decision making process. Lightapp may convince the local facility to join the project, but in many cases it was up to the local facility to persuade corporate headquarters of their need to participate.

Sometimes Lightapp had access to formal decision makers at the corporate level, sometimes not. If dealing with a small company, it was not uncommon for Lightapp to speak directly to the company owner.

Lightapp then contacted facility personnel. The vast majority of Lightapp's initial contact attempts were cold calls to the facility's main phone line. Having identified the plant manager or names of maintenance personnel only meant having a reference when speaking to the receptionist or working through the facility's automated voicemail system, neither of which guaranteed an actual conversation. Contact with the decision maker was rarely made on the first attempt. Lightapp attempted to call each facility 2-3 times per week until a conversation was held. If Lightapp was able to find an email address, they accompanied the weekly phone calls with emails.

When Lightapp was given the opportunity to speak with a decision maker, initial interest was sparked by referring to a "\$5 million grant from the California Energy Commission to lower compressed air energy consumption." At this point, Lightapp also attempted to confirm the true decision maker, gathered email addresses, and determined the facility's eligibility. The sooner Lightapp discovered that a plant cannot participate, the longer Lightapp could spend recruiting viable participants. Beyond this opening strategy, the conversation usually took its natural course in marketing the value of Lightapp to the facility.

Lightapp followed initial contact with an email that included the marketing materials: a link to Lightapp's website, a brochure, a PowerPoint presentation, a video, and the participation agreement. Lightapp checked in with the facility 1-2 times per week via phone or email, whichever elicited a response from the facility. Lightapp used these check-ins to ask the facility if they had any questions about the materials or wanted to schedule a project demonstration. Many facilities scheduled conference calls and allowed Lightapp to deliver their presentation; a fewer number of facilities requested a product demonstration. Lastly, Lightapp maintained a sense of urgency by continually reminding the facility of their deadline to opt into the project. Some facilities were responsive, explaining to Lightapp that participation was undergoing internal review, whereas some facilities were relatively unresponsive. However, Lightapp learned that responsiveness is not necessarily a good indicator of interest in the project.

Recruitment Results

The 70th and final weekly release occurred on February 9, 2018, marking the formal end of the Recruitment phase with 96 facilities recruited into the project. As of March 20, 2018, all 70 weekly releases of facility names reached their 40-day recruitment deadline, and a total of 1,007 names of potential participants were released to Lightapp in total. Originally, 120 sites were recruited into the project, but three locations unexpectedly dropped during the installation and baseline phases after Recruitment was closed. Including the six pilot sites, this brought the total project participants to 102, exceeding the initial project goal of 100 participants.

The remaining 117 potential participants from the Recruitment list were saved for use during the Willingness to Pay (WTP) phase of the project, as uncontacted facilities are one of the groups used to estimate customer’s WTP for an optimized energy management system.

Lightapp attempted to contact all 1,007 facilities. Lightapp made contact and was able to establish a dialogue with 776 (77.1 percent) facilities. All were either recruited, refused to participate, or deemed ineligible to participate.

Figure 3: Recruitment Final Results

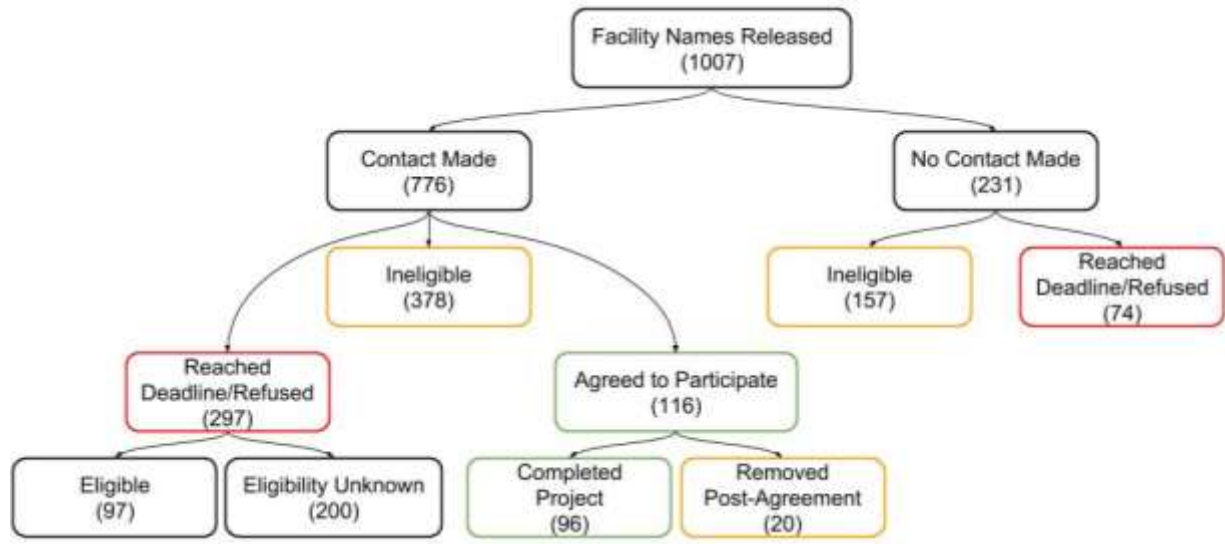

The illustrated recruitment processes showing the breakdown of sites based on facility response.

Source: UC Berkeley

Facilities Recruited

Among the 1,007 site approached, 96 (10 percent) opted into and remained in the project. This represents 22 percent of all eligible industrial facilities, with a take-up rate of 26 percent for sites that received the software free of charge (Gold sites) and 15 percent for sites that received the software at a discounted rate (Blue sites). On average, it took 27 days from the time Lightapp received a facility name for a participant to sign the participation agreement. Ninety-four project participants were manufacturers, one participant was a mining facility, one participant was a petroleum refinery, and one participant was a shipping center. Although the initial list of potential participants included other types of industrial customers such as quarrying, oil and natural gas extraction, and refrigerated warehousing and storage, no facilities from these industries agreed to participate.

Participating facilities were engaged in a wide range of manufacturing specialties. Food manufacturing made up the largest number of sites (27 percent), followed by paper/wood products manufacturing (18 percent), and beverage manufacturing (13 percent). Facilities working with metals, plastics, rubber, building materials, and

equipment were also prominent. Examples include manufacturers of wheels, plastic bags, vehicles and aircraft parts, and metal foundries.

Regardless of sector, compressed air was used primarily for dusting, cooling, drying, and pneumatics. For example, compressed air can be blown between stacks of cardboard to allow another air-operated machine to grab, lift, move, and fold individual sheets. Compressed air can also be used to dry metals and plastics following a water-cooling process, blow mold off of aged meat, move PET pellets and liquid through tubes, or inflate heated plastic into the shape of a bottle.

The 1007 released facilities were distributed throughout California, divided roughly evenly across the service territories of Southern California Edison (SCE) (50.9 percent) and Pacific Gas & Electric (49.1 percent). The participating facilities were also distributed throughout California, although not as evenly, with 63 percent located in SCE's service territory and 37 percent located in PG&E's (Figure 4).

Figure 4: Map of Project Participants

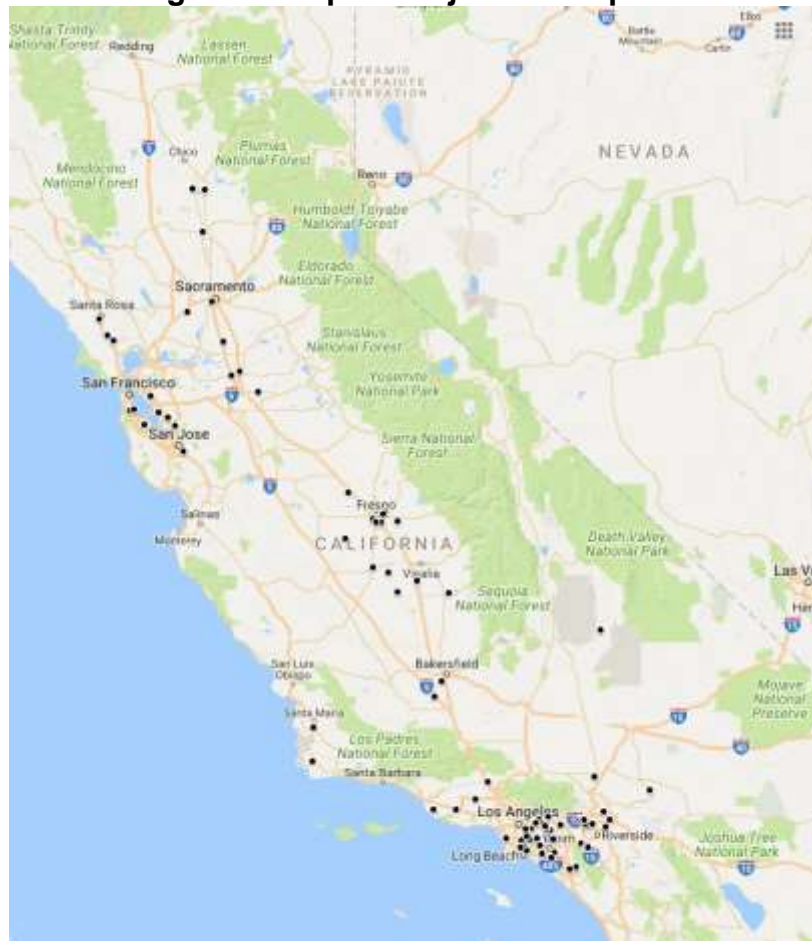

The map shows project participants, including the pilot sites.

Source: UC Berkeley

The Office of Environmental Health Hazard Assessment within the California Environmental Protection Agency created a weighted scoring system, CalEnviroScreen 3.0 (CES), to identify communities disproportionately burdened by pollution and with increased vulnerability to pollution's impact. Vulnerable communities include those with high levels of poverty and unemployment combined with higher prevalence of health issues. Census tracts scored above 75 percent are considered disadvantaged communities, and of the 96 project participants, 73 (72 percent) were located in disadvantaged communities.

Reason for Nonparticipation

Ineligible

Overall, 46.5 percent of the sample was deemed ineligible to participate. Ineligibility was the primary reason for non-participation.

The majority of ineligible facilities (82.1 percent) did not have a compressed air system or had systems that were below 200HP, the cut-off for participation— 38.7 percent and 43.4 percent, respectively. The initial list of industrial sites was provided by the utilities SCE and PG&E. The utilities did not have accurate information regarding a site's horsepower (HP), nor were there other available sources for this information. Given the lack of knowledge about a site's HP prior to contact, this ineligibility rate was not surprising. These ineligible facilities could still be candidates for Lightapp's technology in the future since they often utilize other industrial processes (e.g., boilers, chillers, energy forecasting) that are compatible with the EMS. However, during the period of this project E2e requested that Lightapp not market their product to these otherwise suitable facilities from the randomized list, as well to the facilities with small compressed air systems to focus on project objectives.

The remaining causes of ineligibility were relatively rare. Facilities that closed or had plans to close during the study period make up 12.6 percent of the ineligible sample. A small minority of facilities, 2.3 percent, had highly seasonal schedules of operation. For example, a tomato canning plant that operated only three months out of the year cannot participate because the evaluation needed twelve months of treatment data from each participant. Lastly, about 2.9 percent of ineligible facilities were found to have errors in the utility data or would not agree to the study's participation requirements.

Removal from Project Post-Agreement

Twenty facilities agreed to join the project and signed participation agreements but were unable to move into the installation and baseline phases. These 20 sites were not included in the 96-site recruitment total. Of these sites, seven voluntarily withdrew from the project, primarily due to changes in plant or company priorities and lack of resources to continue moving forward. Another ten sites were dropped by the project team due to difficulties meeting installation deadlines. The decision was made to drop

these ten sites so that treatment of subsequent sites was not unreasonably delayed. One site was dropped from the project due to failure to meet eligibility requirements, as the facility manager was mistaken regarding the total amount of compressed air at the time of recruitment. One site was removed from the project after the initial installation of monitoring equipment, as consistent communications were unable to be established for more than 90 days. The final site was dropped due to the large size of the facility and potential expense of the installation, which made completion infeasible within the budget constraints of the project.

Other Reasons for Nonparticipation

Among the 1,007 facility names contacted, 438 (43.5 percent) declined to participate or had not made a decision by the recruitment deadline. Each week, names were released to Lightapp to recruit into the study but they had to be recruited within 40 days, after which they were deemed as lost. Lightapp was in direct contact with 68.3 percent of these facilities, 22.2 percent of which were confirmed eligible to participate. Lightapp was unable to make contact with the remaining 31.7 percent of refusals.

Facilities rarely went into detail as to why they would not participate, with many facilities giving no reason and simply stating they were “not interested.” However, the most common reason cited for not joining the project was “being too busy” with other projects, end-of-year priorities, beginning-of-year priorities, or just simply stating that “we have too much going on right now.” Ultimately, these facilities could not afford to spend their employees’ time on an additional project or did not believe the project was worth investing employee time and company resources.

Some facilities showed interest, but could not accommodate the project’s recruitment timeline. For example, Lightapp encountered a pharmaceutical preparation facility that required a three month pilot of any new project, followed by a corporate review process and final approval to scale. Other times, local facilities knew from past experience that getting corporate approval could take months. Additional facilities were unable to accommodate projects until future quarters, and could not sign on to participate without an exact date of installation. In the absence of the study restrictions, the Lightapp team was of the opinion that they would have successfully recruited more facilities.

The remaining reasons for nonparticipation were rare. Only eleven facilities claimed to already own an energy management system or be otherwise monitoring compressed air, and a similar number of facilities indicated they were already working on compressor efficiency or were replacing compressor equipment. A small minority of facilities stated outright that their compressed air energy costs were too low to invest time in managing, or that the costs of the project were too high (for sites that were required to pay).

Conclusions and Lessons Learned

Throughout the recruitment period, the engage team identified several key lessons learned that shaped the modifications made during the recruitment process and informed the design of subsequent phases of the project. Some of these critical lessons are:

- Communication with facilities should be simple and straightforward, avoiding use of jargon and buzzwords
 - The level of knowledge about EMS and energy efficiency varied significantly from site to site and within companies
 - Buzzwords such as “Internet of Things” and “revolutionary technology” should be avoided
- Certain industries were often much more difficult to engage with than others, and this should be taken into account if timelines are restricted; however, no industry should be excluded outright, as the requirements vary significantly between facilities within the same industry
 - Pharmaceutical companies, for example, typically had very long pilot periods
 - High technology manufacturers (for example, semiconductor manufacturing) were very cautious about adding any new equipment to their facilities, as the manufacturing process is very precise
- Company size was not a good indicator of participation, nor is compressed air system size above our minimum threshold
 - Recruited facilities ranged from global companies with thousands of manufacturing plants to single plant local manufacturers
 - Compressed air system size ranged from 200HP to more than 2,000HP
- Unlike a normal sales process, the restrictions set by the project requirements limited Lightapp’s ability to recruit all qualified and interested sites
 - If given more time, Lightapp believed they would have achieved a higher participation rate, as many sites were interested, but did not have the time or the resources to participate in the project at the time of recruitment
 - Lightapp’s technology can be applied to many systems outside of compressed air, but sites without compressed were excluded from the scope of the project
 - The subsidized installations and monthly access fees may have increased participation. The level of this impact was tested in the offers to participants during the upcoming Willingness to Pay (WTP) phase

- Energy responsibilities were not owned by one uniform position across different companies and facilities
 - Equipment energy use can be the responsibility of many different departments:
 - Maintenance
 - Local Plant/Facility Operations
 - Corporate Plant/Facility Operations
 - Finance
 - Energy/Sustainability
 - Finding the right contact at each site involved using many different tools, such as LinkedIn, company websites, phone directories, and often required multiple attempts before reaching the correct decision maker
 - This lesson was critical for the ongoing site engagement during the Roll-out and Treatment periods, as well as the WTP phase
- If one facility of a multi-site company joined the project, the recruitment process for any subsequent facilities with that company was expedited, particularly as plant managers observed the impact of the EMS first hand

CHAPTER 4:

Installation and Baseline Data Collection

Following the recruitment phase, each participating facility underwent the installation and baseline phases. Following meter installation and validation, each facility entered into a baseline data collection period of no less than 90 days. During this time, no one at the participating facility had access to the Lightapp software platform or received performance reports or alerts, as the goal was to establish a “business as usual” energy use baseline for each facility. The installation and baseline data collection phases fell into two categories: the initial pilot site and the mass installations. The lessons learned from the Pilot project participants informed the design of the mass installation.

Pilot Installations

Six pilot sites were chosen, systems installed, and baseline data gathered prior to the kick-off of the full recruitment and Installation phases. These six sites served as a test bed for determining the best recruitment methods, finding new installation partners, and optimizing the collection and analysis of the data.

Pilot Method and Lessons Learned

The original pilot design assigned Recruitment of facilities to the two implementation subcontractors who were air compressor service companies. On April 11, 2016, E2e released the names of 50 facilities to each partner and directed the implementers to recruit facilities into the project, survey facility layout, install any necessary meters and communication equipment, and ensure that all meters were configured properly and communicating valid data.

By the July 24, 2016 recruitment deadline, the implementers had recruited and completed installations at only six facilities, a number much lower than expected. Several lessons were learned regarding the root cause of these issues and were used to re-design the recruitment and installation stages (detailed in Section IV, A).

First, the two implementation subcontractors were very experienced in the business of selling and servicing compressed air equipment, but struggled to communicate the value of the Lightapp EMS. The firms were unable to describe the function of the software and the distinction between this program and regular, one-time energy audits. Second, the implementers did not place a high priority on this project, likely due to the sales incentives related to hardware sales and traditional service deals. Third, the implementers were not motivated to sell a next-generation technology solution, leaning instead towards the “low hanging fruit” facilities. Lastly, one of the implementation partners, Osterbauer Compressor Service, was acquired by Ingersoll-Rand in the middle

of the pilot program. This acquisition significantly slowed progress on pilot recruitment and installation.

Pilot Results

The baseline period for the six pilot sites was from August to December 2016. Each pilot site spent at least 90 days in the baseline period. During this time, Lightapp and E2e had access to the site performance data, but the pilot sites did not. Site performance is measured using the Compressed Air System Efficiency (CAS) indicator. CAS shows how much energy (in kilowatts) the site is investing in producing each 100 Cubic Feet per Minute (CFM) of air. A low CAS score indicates a site is operating efficiently, as it is using less energy to produce the same amount of air, while a high CAS score indicates inefficiency.

The six pilot sites had an average baseline CAS score of 25.1, using an average of 119 kW of electricity for compressed air during normal plant operation. Pilot site compressor systems produced an average air flow of 548.2 CFM and maintained an air pressure of 114.1 pounds per square inch (PSI). Details for each site can be found in Table 2 below. The most efficient site, semiconductor and related device manufacturer B, had a CAS score of 14.2, while semiconductor and related device manufacturer A was the least efficient site with a CAS score of 35.1.

Table 2. Baseline Pilot Site Performance Averages

	Kilowatts	Air Pressure	Airflow	CAS Efficiency
Unsupported Plastics Bag Manufacturer	163.5	112.4	521.9	30.6
Semiconductor and Related Device Manufacturer A	127.2	121.1	368.3	35.1
Semiconductor and Related Device Manufacturer B	156.5	110.2	1101.5	14.2
Aluminum Die-Casting Foundry	46.8	100.3	395.5	16.6
Plastics Bottle Manufacturer	83.9	105.9	406.4	25.8
Other Measuring and Controlling Device Manufacturer	135.8	134.4	495.7	28.5
Pilot Sites Average	119.0	114.1	548.2	25.1

Source: UC Berkeley

Each pilot site spent at least 90 days in baseline, but data collection was interrupted due to a number of different factors, which are explained in more detail in the mass installation section of this chapter. The pilot sites collected and transmitted baseline CAS data 53.3 percent of the time, an average lower than individual meter readings, as the CAS calculation requires both the electricity and air flow meters to communicate data.

Figure 5: Example Pilot Site CAS Score Over the Length of the Baseline Period (90 Days)

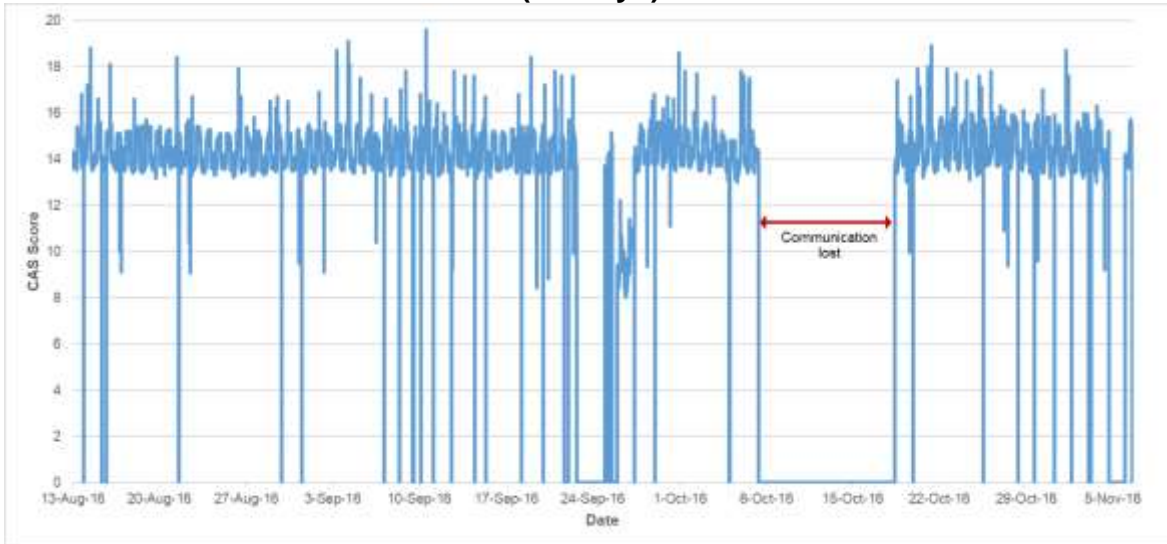

The CAS score over the length of the baseline period for one of the pilot sites and illustrates what a site energy efficiency profile may look like. A zero value for the CAS score indicates a time period where communication with the meters was lost, as indicated by the red arrows on the graph.

Source: UC Berkeley

Mass Installations

Information on the pilot sites is not included in the reporting of the main study population, as the pilot sites were recruited and installed through a different process.

Meters have been installed and data are being collected from 96 sites. 79 sites have completed their baseline period and been granted access to Lightapp analytics; 17 sites are still communicating baseline data and will be granted access to Lightapp in randomized order over the next few months.

Mass Installation Design

Following the pilot period, recruitment and installation procedures were altered significantly to accelerate and streamline the process for the 96 project participants. First, the task of recruiting customers was re-assigned to Lightapp. Lightapp was able to more effectively communicate the merits of the software and gather the data necessary for installation of equipment.

Second, Ingersoll Rand was designated as the lead installer. One of the pilot implementation partners, Osterbauer Compressor Services was purchased by Ingersoll Rand during the spring and summer of 2017. Ingersoll Rand combined the resources from Osterbauer and a second company to form the new Los Angeles District, and this district office coordinates all project activities with Lightapp and the E2e team.

Following Recruitment, each project participant was contacted to obtain detailed compressor information and to schedule an in-person site visit. Ingersoll Rand was given the compressor and site information for each installation site to determine if they wanted to assume responsibility for the installation. Ingersoll Rand evaluated each installation based on the following factors:

- Number and location on compressors
- Amount of equipment needed
- Site location
- Complexity of installation
- Future business potential

In the budget and contract negotiations with Ingersoll Rand, the E2e team had to assume an average installation size and cost. Ingersoll Rand had the right to decline an installation site if the site was more costly than the assumed cost in the contract. These sites were referred to as being out of scope (OOS) for Ingersoll Rand. For some larger sites, E2e and Ingersoll Rand negotiated adjusted budgets to cover additional equipment and labor costs, but these changes only applied to six sites. Lightapp became the implementation partner for all OOS sites and coordinated installations with site personnel, additional third party installation teams, and Lightapp employees.

Ingersoll Rand Installations

Installations at participating sites followed a clear set of steps following the execution of the project agreement, as shown below (Figure 6).

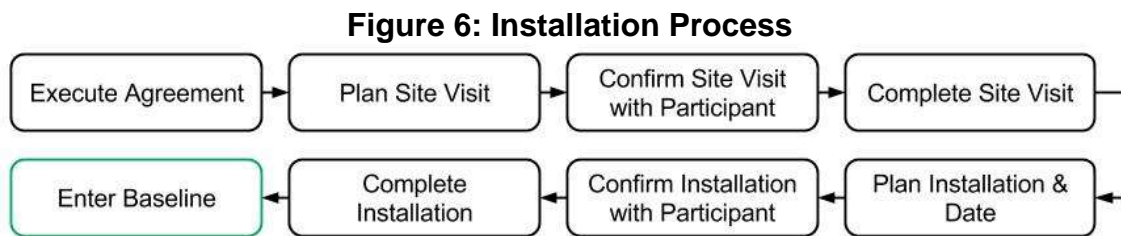

Source: UC Berkeley

Once Ingersoll Rand elected to perform an installation at a participating site, Ingersoll Rand and Lightapp coordinated a site visit. Coordinating and scheduling the site visits took an average of 58 days, and the participating sites took eight days to confirm the proposed dates provided by Ingersoll Rand and Lightapp. Site visits took place on average 14 days after confirmation was received from the customer.

Following the completed site visit, Ingersoll Rand provided detailed site information to Lightapp, including details regarding the compressor specifications, facility layout, and sensors needed. Lightapp uploaded this information into the software platform, creating the site map. Ingersoll Rand subsequently ordered the necessary parts and scheduled the installation with the participant, a process that took 56 days on average. An additional 14 days typically passed before a participating site confirmed the installation date and coordinated details with Ingersoll Rand. On average, 12 additional days passed between confirmation of the installation dates and the beginning of the installation. They paid attention

Once Ingersoll Rand arrived at an installation, they began the process of installing all meters and communication devices. The order and arrangement of the equipment varied greatly from site to site based on the layout of the compressed air system. After the installation of all flow, pressure, and electricity meters, Ingersoll Rand worked with Lightapp to enter the meter information into the previously created site map. As the physical meters were linked with Lightapp’s software through the cloud-based server, Ingersoll Rand remained on site to confirm that data were being communicated properly and that the meters were reading accurately. The physical installation was often completed in 2-3 days, but many sites experienced communication and data flow issues when first receiving the equipment. On average, it took 22 days from the start of the installation until data collection was verified and the site entered into Baseline. In total, 184 days elapsed between when a site signs on to participate in the project until they enter Baseline. A summary table of this information is available in Table 3.

Table 3. Mass Installation Timing Details

Project Stage	Ingersoll Rand Sites	Lightapp Sites
Planning Site Visit	58.3	18.3
Confirming Site Visit Date w/Customer	8.1	11.3
Awaiting Site Visit Date	13.5	16.9
Planning Install & Date	56.3	146.7
Confirming Install Date w/Customer	14.5	17.5
Awaiting Install Date	11.9	16.6
Install in Progress	20.9	33.9
Baseline Period	134.0	101.1
Total Install Period	184.5	254.4

Source: UC Berkeley

Out-of-Scope Installations

Out-of-scope installations took place in a similar manner to the standard, or “in-scope” installations performed by Ingersoll Rand; however, Lightapp coordinated the installation labor with site personnel and third party installation partners. These installations were typically larger than the Ingersoll Rand installations; participants had a higher number of compressors and required more meters and installation labor than a typical site. As these sites were somewhat irregular, the installation process and length of time between each step varied quite significantly.

Of the 96 project participants, seven installations were completed by Lightapp and their installation partners. A summary table showing the average time between each step in the installation process as shown.

Mass Installation Results

Baseline Data Collection

As was done in the pilot sites, each participant spent at least 90 days in the baseline period to establish the “business as usual” energy profile. During this time, Lightapp and E2e had access to the site performance data, but the participants did not. At the time of this report, 78 participants had 90 or more days of baseline data. The performance results shown below use data from the 76 participants that completed the 90 day baseline period and entered treatment. Two sites were excluded from the analysis due to insufficient or inaccurate data.

Site performance was measured using the CAS indicator, as was done with the pilot sites. Data showing electricity usage, air pressure, and air flow from each compressed air system at the participant sites were collected. While the majority of sites combined all compressors into a single system, a small number of sites had multiple compressed air systems. Data from each sub-system was collected independently at these sites, and the CAS score was calculated for each sub-system independently.

Data Configuration and Connection

Validation of data was a critical step during the installation process. Throughout the main installation rollout, multiple types of meters for reading electricity, pressure, and flow were used depending on the facility needs. Confirming that each meter was configured correctly and communicating accurately was critical to develop an accurate baseline and for measurement of treatment performance following the baseline period.

While on site, the installation team contacted the Lightapp support team to configure the meters and communication devices. Each piece of physical equipment was linked to the corresponding entry in the site map; for example, the electricity meter on Compressor #1 was linked to the Compressor #1 entry on Lightapp that contained the corresponding equipment information (such as compressor size, age, and other relevant metadata). After each meter was linked, the teams worked to validate the data. The

Lightapp team reviewed the data they received from each meter and compared the readings to those taken by the installation team on site. For example, the Lightapp team would see that an electricity meter is reading 50 kilowatts (kW), and they would then ask the installation team to take a local reading. If the meter was configured correctly, the local reading should also be 50 kW, matching the data communicated to the Lightapp software.

Each meter was fully validated prior to the site entering the baseline period. After Lightapp and Ingersoll Rand validated the data, the E2e team checked the site and ensured communication of data persists for 24 hours prior to entering the participant into baseline.

Throughout the installation and baseline periods, maintaining consistent data communication and receiving valid data were primary concerns. Participant sites lost data connectivity for a number of reasons, including loss of power to the meters, loss of power to the communication device, and failure of the internet connection. The communication devices at each site were capable of storing data should the internet connection be lost, but if the device itself failed the data are not recoverable.

Data configuration was monitored by Lightapp, Ingersoll Rand, and E2e team using the Site Status page on Lightapp's online portal. This section was developed throughout the course of the pilot and mass installations, and it aggregated all participating sites into one page for easy monitoring of data communication issues. The Site Status page was developed by Lightapp and the E2e team after experiencing problems ensuring that communication issues were addressed in an accurate and timely manner. Sites were ranked based on the percentage of meters that were reading accurately and consistently, and could be sorted to prioritize where troubleshooting or site visits were needed.

When a site stopped communicating data, Lightapp support first checked the connection to determine if it was a site issue or server issue. If it was a server issue, Lightapp support worked to get the server back online, and typically any missed data could be restored. If it was a site issue, Lightapp support got in contact with site personnel for troubleshooting, such as checking to ensure the communication device was plugged in, verifying no circuits were tripped, and confirming that the air compressors were running. When remote troubleshooting did not fix the issue, technicians from either Lightapp or Ingersoll Rand were dispatched to the site to determine the root cause. Technicians made the on-site repairs, replaced faulty or broken equipment, and ensured that communication is restored and any locally stored data was uploaded.

Baseline Performance Results

The participant sites had an average baseline CAS score of 24.4, using an average of 155.3 kW of electricity during normal plant operation. Participant compressor systems produced an average air flow of 746.3 CFM and maintained an air pressure of 107.6

PSI. An electronics manufacturer was the most efficient site with a CAS score of 10.7, while a commercial bakery was the least efficient site with a CAS score of 52.7. Participants experienced 80 percent average data continuity, although sites varied significantly, with a poultry processor experiencing the highest data continuity at 99.2 percent and a nonferrous forge experiencing the lowest continuity at 3.6 percent. Details regarding these averages are shown in Table 4. The average CAS score for each site is plotted against the air flow (CFM) produced at each site in Figure 7 to show the grouping of participants. The most efficient sites are in the lower half of the graph, producing the lowest CAS score.

Table 4: Baseline Site Performance Averages

	Kilowatts	Air Pressure	Airflow	CAS Efficiency
Average Values	83.9	105.9	406.4	25.8
Average Continuity	135.8	134.4	495.7	28.5
Average Number of Data Points	119.0	114.1	548.2	25.1

Source: UC Berkeley

Figure 7: Baseline Performance of Mass Installation Sites

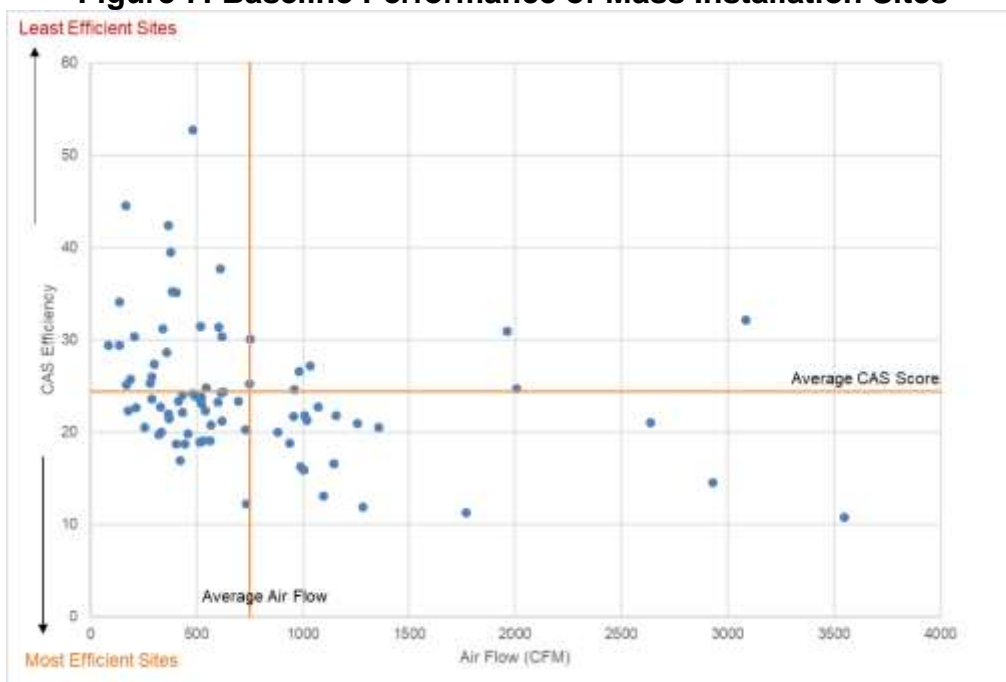

Source: UC Berkeley

The Lightapp software displayed the baseline use in the energy dashboard, which then translated energy use into dollars spent. The baseline data described was compared to the same figures from each site following the treatment period, wherein the site staff

had access to Lightapp. Changes observed between the baseline and treatment data, such as higher CFM and lower CAS scores, were used as performance indicators and converted into monetary units to measure any spend increases or decreases as a result of the Lightapp system.

Participants used in this analysis specialized in a variety of manufacturing types. Food manufacturers made up the highest percentage of facilities, 39.7 percent, followed by paper, wood, and plastics manufacturers at 21.8 percent. Equipment manufacturers and metal and resin manufacturers made up 10.3 percent and 9.0 percent of the sample respectively. Different areas of manufacturing also showed different performance averages. Vehicle manufacturers were the least efficient with an average CAS score of 27.2, while cement, concrete, and refineries used the highest amount of electricity at 227.5 kW. Table 5 shows the sample breakdown and average values in detail.

Table 5: Baseline Site Performance Averages by Industry

Industry	Percentage of Sample	KW	Air Pressure	Airflow	CAS Efficiency
Food and Beverage Manufacturing	39.7	175.8	104.4	810.0	24.5
Paper, Wood, and Plastic Manufacturing	21.8	164.2	101.4	748.7	24.5
Equipment Manufacturing	10.3	120.0	122.3	533.7	25.2
Metal and Resin Manufacturing	9.0	120.3	119.7	542.5	25.2
Other	7.7	141.1	107.6	1007.8	19.8
Vehicle Manufacturing	7.7	103.9	103.8	450.9	27.2
Cement, Concrete, and Refineries	3.8	227.5	108.3	1235.3	23.0
All Manufacturing		155.3	107.6	746.3	24.4

Source: UC Berkeley

Conclusions and Next Steps

After 96 completed installations and 78 sites with completed Baseline periods, the Engage team learned a number of critical lessons that informed the Roll-out of the Lightapp software to site personnel and the design of the WTP phase. These include:

- A longer Baseline period provided more data, which enhanced the evaluation but ran the risk of losing engagement with facility personnel

- Some sites were recruited quickly, but the installation took longer to schedule and complete. Other sites agreed to participate and the installation was quickly done. Because the treatment portion of the project had to follow the original randomized order, this led to sites with differing baselines. All Baseline periods are at least 90 days, but some were as high as 200 days.
- Some sites experienced much longer than 90 day Baseline periods, and these sites tended to be more difficult to re-engage in the project than those with closer to 90 day Baselines
- A few sites also expressed impatience during the Baseline period, as the site team was eager to have access to the data
- It was vital to maintain data communication during the Baseline period, otherwise the Engage team could not establish a “business as usual” profile for a facility
- Although facility personnel were not engaged during the Baseline Period, Lightapp monitored this data to ensure accuracy and identify potential problems at the site impacted data integrity, such as compressor repairs or other communication failures
- In the event that communication was severed, having the ability to store meter data on site was invaluable
 - Several sites experienced persistent internet issues during Baseline, but Lightapp was able to go to the facility and recover the missing information
 - Multiple iterations of the communication devices were used throughout the installation and Baseline periods to find the most stable way to ensure data flow

CHAPTER 5:

Software Engagement Period

After establishing a baseline period of at least 90 days, sites entered into the roll-out or treatment phase for twelve months. Facility personnel were given access to view data and analyses specific to their site on the Lightapp software, and received additional reports and insights from the Lightapp team. The treatment period was when facilities first have the opportunity to act upon the information provided by the Lightapp software to optimize the energy efficiency and associated operations of compressed air systems.

Roll-Out Method

The E2e team tracked the baseline period of each participant, ensuring that each site was in baseline for at least 90 days and that the Roll-out follows the randomized order established prior to the recruitment period. Preserving this order was essential to the validity of the RED, but caused some sites to remain in baseline for longer than 90 days. A site that was later in the randomized order could be installed before an earlier site, but could not enter the treatment period until all previous sites completed Baseline. To prevent too many sites from entering treatment simultaneously, Roll-out was limited to three sites per week. An extended build-up of sites waiting to enter treatment later during the project period caused an exception to this rule to occur in November 2018, where seven sites were released one week and an additional seven released the following week.

When a participant site was close to the end of the baseline period, the E2e team informed Lightapp to prepare the site for roll-out. Lightapp prepared the site by making sure Lightapp had all the necessary information for roll-out, such as the names and email addresses of all facility personnel that received access to Lightapp. When baseline was complete, Lightapp sent out login instructions to the facility personnel in the form of an invitation email that contained a username and instructions. Personnel were prompted to use links in the invitation email to set up their Lightapp account. These emails continued to be sent out until each participant created their account and logs in. Upon setting up an account, the user had access to all the different facets of Lightapp and were free to browse and review the available data and user guides.

Interactions were generally grouped into three different categories: site messaging, scheduled reports, and notifications. The goal of all interactions was to encourage the participants to compare current site performance to baseline performance and to anonymously compare their site to other project sites. First, the Lightapp software automatically prompted a "Getting Started" message and guide when the user first logs in, explaining how to use each page and interpret the site-specific data. After a short

period of time wherein the user can get accustomed to the Lightapp system, they began receiving system tips and actions they can take to improve compressor efficiency, such as analyses of performances and an overview of activation logic. After users were familiar with the data related to their site, Lightapp prompted the users to examine the arena; a page where participants could view their CAS efficiency scores as compared to other sites in the project. All data were anonymized, but users could sort based on the general industry. For example, a soda manufacturer could compare their plant to general manufacturing sites, plants specializing in food products, or compare directly to other beverage manufacturers. In the event one company had multiple different plants with Lightapp access, they could directly compare these sites to each other in detail.

When a participant site entered treatment, the facility personnel also received scheduled reports on a weekly basis. These reports showed the general air compressor performance, including electricity consumption, average airflow, average air pressure, and the CAS efficiency. Each week compared current performance to baseline performance and the previous week's performance. The reports also interpreted the energy data in term of energy expenditure, with a specific dollar amount behind various problems and potential changes. Users could also go into the Lightapp software and customize these reports, specifying what data were most useful to them and the frequency of communications. Reports could be exported from the site at will and customized along the following parameters:

- Type of data
- Time period of report
- Data resolution (5 minutes, 15 minutes, 30 minutes, hour, day, week, month)
- Time pattern (for example, excluding weekends)
- Event type
- Report frequency
- Report format (Excel file, CSV, PDF)
- Users or email addresses to receive the report

The third group of communications consist of notifications about tasks that the user needed to complete. These tasks included adding information about equipment (such as the year a compressor was installed at the site), resetting onsite communication devices, prompt to add events (such as holidays and scheduled down time), and questions about data completion. Notifications were not sent on a schedule, but sent out by the Lightapp system as needed. For example, if the Lightapp team determined that a plant has a change in operational patterns, they worked with the plant team to determine if an event, such as scheduled maintenance/down time, took place, then noted this event in Lightapp. Keeping track of all key events and changes at plants in one place acted not only as a resource for the site personnel, but also for identification of anomalies in future analysis. Notifications also took the form of performance alerts,

where the Lightapp software identified abnormalities in equipment function, such as leakages, high blow-off, and high CES efficiency scores, all of which could result in increased energy costs. These alert parameters could be specified by facility personnel to their preferred level of sensitivity.

Throughout this process, the participants often contacted Lightapp with questions and requests. Some common questions were:

- Who can help us with making changes to compressor settings?
- Can we receive additional training from Lightapp to best utilize this software?
- What are the best avenues to increase our efficiency based on the data?

The Lightapp team worked closely with participants to address these questions and provided additional resources and recommendations for energy optimization.

Roll-Out Results

Initial Roll-Out of Lightapp Software and Services

At the time of this report, 78 participant sites (not including pilot sites) have entered the roll-out phase and have access to the Lightapp EMS and data. On average, three site personnel received Lightapp login credentials and were sent the weekly reports, although participant sites varied from one to ten users per facility. At the time of this report, 272 unique users from the participant sites logged into Lightapp since the beginning of roll-out.

The first participants entered the roll-out phase of the project in March 2017. As shown in Figure 8, the number of users that used the EMS each month varies, but averaged 26 unique users per month. Each color indicates a different user. Each user viewed an average of nine different pages within the EMS during a month, with the pages most frequently visited being the "Compressed Air System Real-Time Analysis," "Site Map", and "AirComp Performance." The "Compressed Air System Real-Time Analysis" page and "AirComp Performance" pages showed the performance of each air compressor in terms of energy usage, air pressure maintained, air flow, and CAS efficiency in real time compared to the Baseline measurements. These two pages also showed site performance over the course of a week, although this frequency could be customized by the user. It displayed site performance compared to the Baseline efficiency, the performance of the site during the previous week, and the average performance of all sites participating in the project. The "Site Map" page displayed the organization of each participant and links the different meters to different pieces of equipment, as well as meta-data associated with the compressors.

Figure 8: Lightapp Login Frequency and User Data

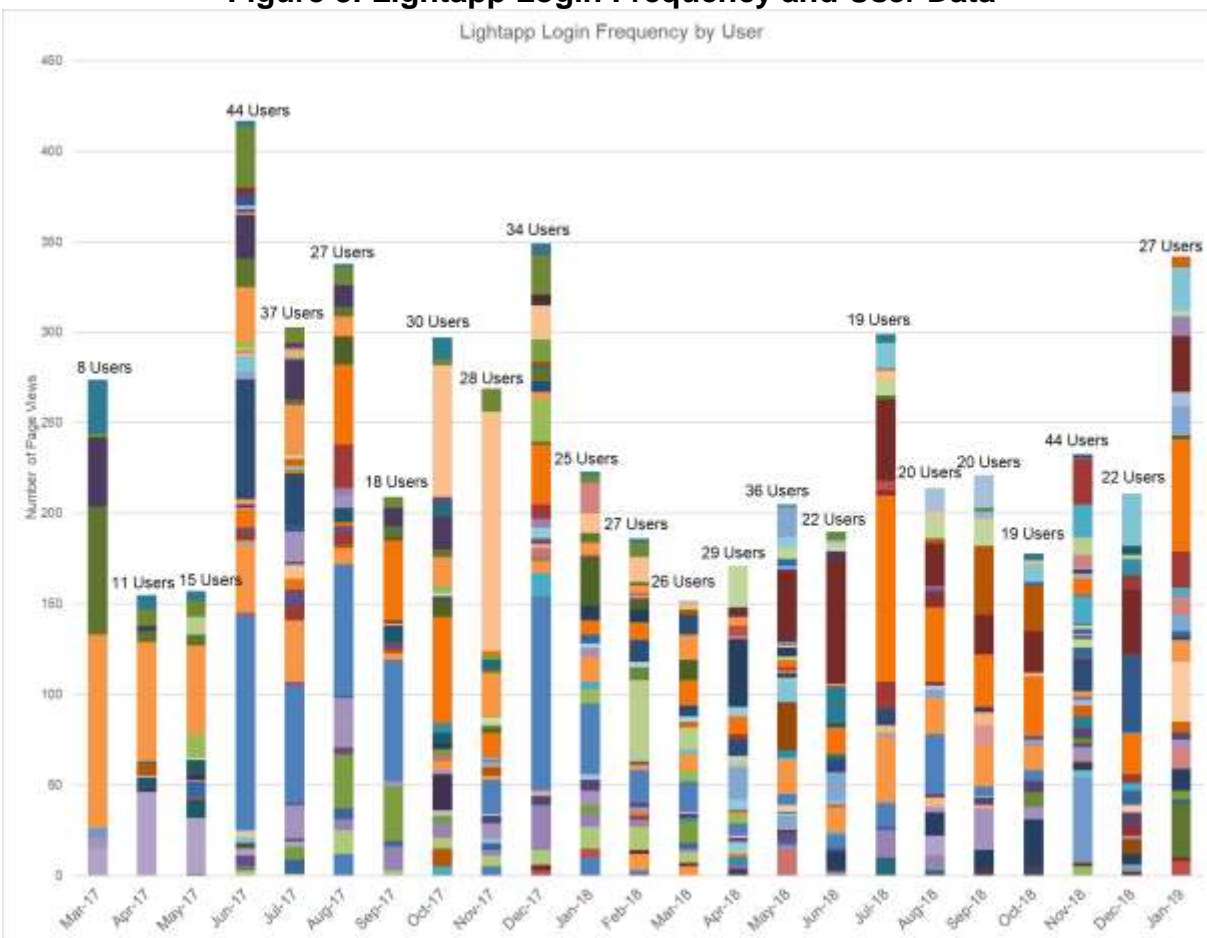

Source: UC Berkeley

Expansion of Lightapp Software and Services

Throughout their treatment periods, several participants expressed interest in expanding the use of Lightapp’s EMS technology outside of compressed air systems. The design of the project prohibited Lightapp from pushing expansion to participants to focus the scope of the project, but site personnel could take the initiative to request expansion of the Lightapp EMS to other production systems. While each participant was unique, typically the site personnel worked first to optimize the compressed air energy usage utilizing the data and analytics provided by the Lightapp EMS. In addition to energy savings, participants saw the value of real-time data and analytics to enable continuous improvement. The 78 sites in Treatment were managed by 73 companies (two companies managed three sites each and one company managed two sites), and 19 (23 percent) of those companies either expressed interest in expansion or completed expansion projects.

After the compressed air systems, participants typically looked towards their next biggest pain point, which was not necessarily be the largest in terms of energy cost, indicating that the site teams saw value in streamlining the plant processes in addition

to reducing expenditures. The largest pain point varied greatly by industry, ranging from production equipment to steam systems and chillers. Another key observation was that the plants interested in expansion were not necessarily the ones that saw the largest energy savings. Several plants, including one with seasonal peaks, did not see major improvements in energy efficiency with their compressed air systems, but saw the added value of a tool that made sense of data and focused on operational excellence. One of the key goals of the Lightapp system was to allow comparison between facilities within the same industry, and many participants expressed interest in seeing an industry benchmark and that they were motivated by this comparison.

At the time of this report, several participants added meters to systems outside of compressed air, including production equipment, high pressure systems, and chillers. A few participants also expanded to plants outside of the project area (outside California). These installations took place separate from the project. One participant used Lightapp's data to test other technologies intended to reduce motor vibration, as Lightapp's real time data provided instant feedback on whether or not the new technology was working. Previously, participants had no way to monitor the performance of individual pieces of equipment, and building a case for new technology was much more difficult.

Conclusions and Lessons Learned

The Roll-out process produced several key lessons learned and was adapted over the course of the project to meet changing participant needs. These lessons include:

- Modifying the language in weekly reports to reduce complexity
 - Site personnel typically only have a few minutes to review reports, so the information displayed needed to be concise and only highlight key points or necessary actions
 - Reports were also customizable, so participants could select or remove parts based on interest
- The alert parameters at the beginning of the project were set too low (i.e. were too sensitive), causing an excessive number of alert emails to be sent to participants
 - Parameters were raised to prevent this problem from continuing
 - When alerts were triggered constantly, site personnel began to regard them as unimportant and ignored them
 - Lightapp worked closely with participants to fine tune the alerts
- Putting a dollar value on specific problems (i.e. leaks) or recommended actions (i.e. changes in compressor settings) seemed to be the most effective way to encourage changes at participant sites
 - Often the plant team operated on a tight budget, so being able to put solid numbers behind changes improved the chances of management approval for equipment repair and replacement

- Some energy efficiency actions did not require financial investment, but resulted in substantial savings, a win-win for the plant team
- Industrial customers were not the only entities interested in this technology, equipment suppliers and manufacturing interest groups also saw value in data and monitoring. This fact was taken into account when developing a plan for full commercialization
 - Manufacturing interest groups expressed interest in working with the project team for future collaborations
 - Sales and maintenance personnel from Ingersoll-Rand worked with the Lightapp team and participant sites to integrate the data into their equipment diagnostic and replacement proposals
- Keeping sites engaged throughout the Treatment period was critical for project success:
 - Participants varied in terms of engagement levels, and each facility had a different reason for being interested in the project
 - The most effective means of engaging participants was a direct conversation, either in person or remote, discussing the actual results seen by the Lightapp EMS
 - Site personnel were particularly interested in how their performance compares to other facilities, even within the same company
 - Maintaining consistent communication aided in transitioning participants through the next stages of the project, including the Willingness to Pay phase
- High turnover rate of facility personnel presented challenges:
 - Keeping in regular contact with facilities to remind them of the project helped reduce this, but it was often difficult to get in touch with the right people at each site
 - This was especially a problem when there was a long wait time between first signing up for the project and installation or between installation and treatment
 - The structure of the project randomization added to these challenges; outside of this project Lightapp would expect to move more quickly with customers to maintain engagement
- Participant interest in expanding the use of the Lightapp EMS beyond compressed air was an indicator of the demand for this type of technology
 - Plant managers and corporate energy teams saw the value of real-time data
 - Site personnel were able to transfer the benefits seen from the compressed air system into new applications, such as in the testing of new sensors and equipment and as a method for convincing company leadership to invest in preventative maintenance and repair.

CHAPTER 6:

Data Analysis and Evaluation of Savings

One of the key project goals was to isolate and measure electricity consumption reductions in the compressed air systems at the participating industrial facilities, and subsequently determine the participant cost savings attributable to the Lightapp EMS. The results of the randomized control trials (RCT) estimate the impact of the Lightapp EMS on facility electricity use in kilowatt hours (kWh) and dollars.

Using a randomized design was key to estimate accurately the effect of the Lightapp EMS on energy usage and cost. First, randomizing the marketing and discounts for the technology across the industrial facilities in PG&E's and SCE's service territories guarded against selecting only industrial facilities within a certain area or that show added initiative concerning energy efficiency, which could skew the results. After the initial list of facilities was created, the order of the facilities was randomized and released in tranches to Lightapp for recruitment into the project, further preventing any selection or prioritization bias.

Once the facilities were recruited into the project and the equipment installed, all participants entered a baseline period of no less than 90 days, wherein the Lightapp EMS gathered data on the performance of the compressed air system. Facility personnel did not have access to the data or reports during the baseline period. This established a "business as usual" compressed air energy usage baseline, which was essential for determining what changes in use and cost were due to the introduction of the Lightapp EMS. Participant facilities also received treatment in the same randomized order.

After collecting at least 90 days of baseline data, participants began the 12-month treatment period. The treatment period lasted for 12 months to gain a full view of site performance throughout a year and capture any seasonal variance, which allowed the research team to account for these changes during the results analysis. Once in treatment, facility personnel were given log-ins to the Lightapp EMS. There they viewed real-time data, customized reports showing compressor performance, customized notifications, and compared the performance of their site to other project participants, although the names of facilities were kept anonymous. As each site entered treatment, the Lightapp EMS continued gathering electricity use, air flow, and pressure data from the compressed air systems, and also kept track of major events or changes that were made to the system during the 12 month period. For example, the Lightapp EMS tracked holidays, shut-downs for maintenance, and equipment replacement, all of which might impact electricity use. Although facilities with highly seasonal patterns of operation were excluded from the project, it was possible that participating facilities still demonstrated a level of seasonal scaling during normal operations, which could impact the perceived effect of the Lightapp EMS.

A number of the facilities have not yet completed their full 12 month treatment period. The analyses in this report are done using the data from facilities that have had significant experience with the EMS. The research team will submit an addendum to this report once treatment data has been collected and analyzed for all participating facilities.

Many factors could impact the estimation of energy savings at participant sites, including weather, production, location, time of year, and length of time with access to the Lightapp EMS. To obtain the most accurate representation of the true impact of Lightapp's services, all of these factors were included in the detailed analysis described.

Method

Data Aggregation

The research team assessed the performance of the Lightapp EMS by measuring the change of two main outcomes: total electricity use (kWh) and total electricity cost (\$). Evaluating use and cost provided the most complete picture of the value of the Lightapp EMS to the industrial facilities.

Data analysis was done using 5-minute and weekly aggregated data. The Lightapp EMS gathered the electricity use of individual compressors at a facility in five-minute increments, then aggregated the use from each compressor into the total use per compressed air system in each facility. For the weekly data, the 5-minute data for each compressor was aggregated over the week, and the electricity use of all compressors at a facility were added together for a weekly total for each site. A facility typically had multiple compressors in one system, and the production equipment demanded compressed air from those machines at different times and rates. One compressor may be used constantly while another is used only as back-up, but occasionally the machines switch roles. By combining the electricity usage of all compressors at a facility, shifts in compressor usage could be identified and accounted for in the analysis. If the research team only looked at individual compressors, they could misinterpret a drop in use at one compressor for savings, when in truth the use was simply transferred to another compressor in that system.

Some five-minute electricity use readings within a week were missing due to intermittent communication issues, such as the internet service dropping or a piece of equipment failing to transmit a reading during an interval. The research team tested several methods for imputing the missing readings:

1. Using the average of the five-minute readings immediately before and after the missing reading
2. Using the rest of the facility data to determine an average five-minute reading for each hour of each day of the week for each site, and use the corresponding average to fill in gaps

3. Carrying the last value before missing data forward to fill in the gaps
4. Linear interpolation: using the average of the last value before missing data and the first value after the data gap to fill in the missing readings

Each of these options were tested to determine the most robust methods for imputing the data. The two methods, using the last value carried forward and linear interpolation, both yielded consistent and significant results, and both methods were used to develop the results described in this report. Weekly observations with a percentage of missing data points over a set threshold were also dropped from the analysis. For this report, the threshold used was 25 percent, and weeks that were missing more than 25 percent of the underlying 5-minute data were dropped from the analysis.

For this report, total electricity cost was estimated using the average utility rates for industrial customers from PG&E and SCE. This rate was multiplied by the total electricity use to estimate the cost impact of the Lightapp EMS. In future reports and papers, the electricity cost may be calculated differently to account for demand charges.

Regression Model

Estimating the treatment impact of the Lightapp EMS was done using regression models with several different specifications. Models were built using only the available raw data and a second set was built using imputed data. A full explanation of the equations used for the model can be found in Appendix B. When examining the 5-minute data, four different specifications were used. These specifications are known as “fixed effects” and impacted the results to varying degrees. By controlling and accounting for these variables, the analysis provided a robust estimate of the specific impact of the Lightapp EMS on compressed air electricity usage and cost.

1. Facility fixed effects- this variable accounts for the differences between each facility, such as the size of the compressed air system and run-times
2. The day of the week- this variable can be important as some facilities run during weekends while others shut down
3. The hour of the day- accounts for differences in day and night compressor usage
4. Day-of-Week x Hour-of-Day- this variable combines the day of the week and hour of the day for more robust control of the effect of time

For the weekly data, only the facility fixed effects were used in the regression analysis, as the aggregated data eliminated the need to account for the other three time-based variables. Each data point also had an indicator variable for whether or not the Lightapp treatment was in effect, and using the data from all sites together identified the overall change in facility performance during the Lightapp EMS treatment period.

Analysis Constraints

At the time of this report, multiple factors constrained the results of the analysis. One important constraint was the incomplete data set used in the current analysis. As stated previously, the baseline and treatment data set does not include all project participants, as not all sites have 90 days of baseline data nor one year of treatment. The results reported were obtained using preliminary data from a subset of participating sites. The research team will submit an addendum to this report once treatment data has been collected and analyzed for all participating facilities.

Second, the project team was unable to obtain industrial production data from most facilities during the project, hence this information was not included in the analysis for this report. Changes in production could significantly influence the energy use in industrial facilities, as more production causes more use of equipment, including compressed air systems. The increase in compressed air electricity use could be due to increased production rather than any changes in system efficiency. Obtaining the production data for the project sites would take this variable into account and further separate the true impact of the Lightapp EMS.

Weather data for the time period of baseline and treatment for all sites could not be obtained for this draft of the final report, but will be present in the final version. The research team will obtain data based on the zip code for each industrial facility and will integrate the following data points into the regression:

- Air temperature
- Atmospheric pressure
- Humidity

Although the compressed air systems and production equipment were situated inside the industrial facilities, the source air was pulled from the outside. These weather factors can impact the efficiency of compressor performance. For example, high humidity may cause the system dryers to work harder, thereby consuming more electricity regardless of the production needs or impact of the Lightapp EMS.

As part of the analysis, the research team ran regression models using the CAS data, air flow/kWh, and pressure/kWh to determine if any statistically significant results could be obtained. At this time, the results from these analyses did not yield anything determinant, and these interactions will continue to be examined as additional data is collected.

Savings Analysis Preliminary Results

To estimate the energy efficiency impacts of the Lightapp EMS, the research team focused on the change in electricity used (kWh). If the Lightapp EMS improved energy efficiency, this would be demonstrated by a negative change in electricity usage (kWh).

Five regression models were run, each using different control variables. Four regressions used the 5-minute data and take different time-based variables into account. One regression used the weekly aggregated data. More details on these regressions can be found in Appendix B. For the results in this report, the research team used the average of the statistically significant outcomes as the resulting impact of the Lightapp EMS, showing the results for both last value carried forward and linear interpolation for the imputed data.

For the facilities that have been analyzed so far, the annualized impact is:

- 6,292,000 kWh/year in reduced consumption
- \$812,000/year in lower bills
- 1,500 tons/year in GHG emissions

Conclusions and Lessons Learned

Individual facility results vary significantly and were likely affected by a number of outside factors, including facility engagement, production, and weather, but these effects could not be isolated. The use of an RCT to identify the overall impact of the Lightapp EMS was far more robust than standard practice for previous energy efficiency technologies, and provided increased confidence in the performance of the Lightapp EMS.

CHAPTER 7:

Willingness to Pay

Willingness to pay (WTP) studies are conducted to determine the optimal price for a good or service. The key research questions for this phase were:

- What is the demand curve and potential market for EMS's and similar analytical technologies across large industries in California? And how does experience with Lightapp's technology shift the demand curve?
- How much do interest, savings, and WTP vary across different industrial sectors in California?

The study design sought to answer these research questions by communicating with engage project participant sites and new facilities that were not approached as part of the Recruitment phase.

Implemented Design

After the results of the recruitment phase, the WTP design was refined to better accommodate industrial customer needs and interests. In addition, specific details about the approach, such as timing, deadlines, and product offerings, were finalized, taking into account input from the research team and the Lightapp sales team. The steps and options for participant facilities are summarized in **Error! Reference source not found.** First, each participating facility was contacted at the beginning of the 11th month of treatment, at which point the research team released the participant to Lightapp to begin the WTP period. Each participant had 90 days to make their decision. The Lightapp team contacted the site personnel and began the process by explaining that the project was coming to a close and that they may continue using Lightapp through a subscription. Participants were presented with site-specific data and results, as well as estimations of their return-on-investment (ROI) for the monthly subscription, although they were not informed of the overall study results. The Lightapp team then generated a quote for the EMS services, taking into account multiple factors, including number of users, data streams, and level of customization.

After Lightapp provided each participant with a quote, participant sites were given five options:

1. Sign up to pay for Lightapp services at the WTP price
 - a. Participants could subscribe via a monthly plan or an annual plan
 - b. Lightapp must honor the WTP price for one calendar year

Figure 9: Willingness to Participate Process Flow

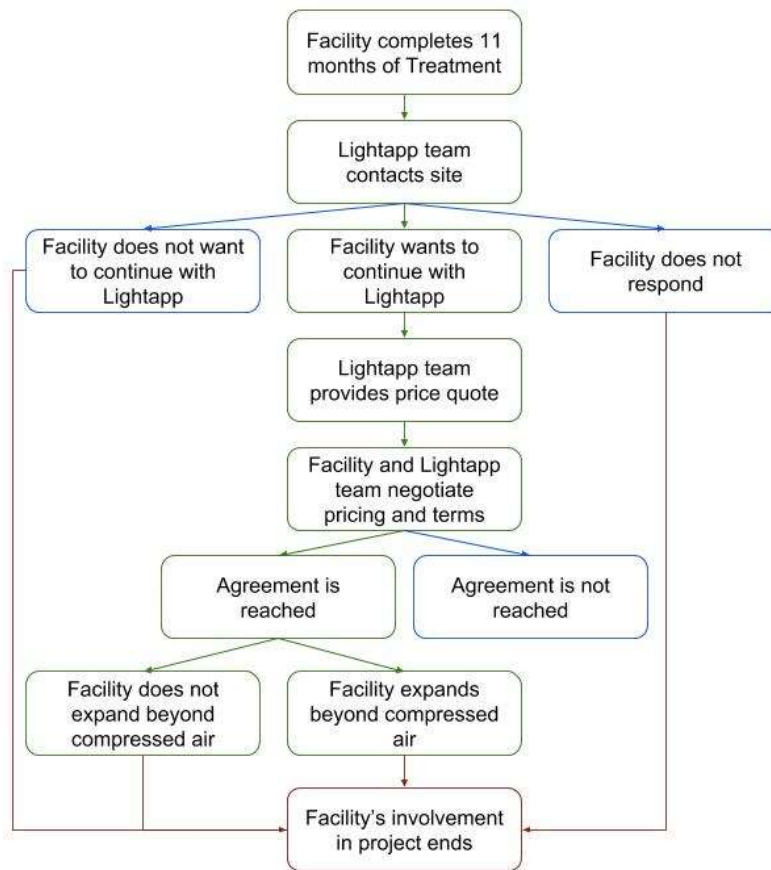

Source: UC Berkeley

2. Sign up for Lightapp services at the WTP price and expand into new plant systems
 - a. Participants do not have to install the equipment on new systems within the 90 day period
 - b. Compressed air system pricing is independent of the pricing for new systems
 - c. Participant sites pay fully for installation of any new equipment
3. Stop Lightapp services but leave the equipment in place
 - a. Lightapp cannot re-approach these sites for one calendar year
4. Stop Lightapp services and have the equipment removed
 - a. Lightapp cannot re-approach these sites for one calendar year
 - b. Per the contract, Ingersoll Rand will remove the equipment at sites where they performed the install; Lightapp will remove equipment from sites where they installed the equipment
5. Stop Lightapp services for compressed air but pay to install equipment on other systems (chillers, etc.)

- a. Lightapp charges list price for any new equipment
- b. Participant sites pay fully for installation of any new equipment

Once each participant site made its decision or the 90-day deadline was reached, whichever date was sooner, the project period ended for that customer. The research team did not use any data collected by Lightapp after this point, and the relationship with participants that decided to continue using the EMS was managed solely by Lightapp.

Original Design

The WTP design proposed at the beginning of the engage project consisted of two main facets: approaching the participating customers and approaching new facilities. While the details of the methods were not defined, several key factors were included.

The project team was to approach the participating customers at the end of the treatment period and explain that the study had ended. The customers could continue to receive Lightapp services for a monthly subscription fee. This subscription fee was to be determined by the following process:

1. Each customer would be asked to state what price they were willing to pay for Lightapp services
2. The research team randomly generates a price for the customer
3. If the randomly generated price is lower than the customers stated WTP, then the customer is allowed to continue the Lightapp service at the revealed pricing
4. If the randomly generated price is higher than the customers stated WTP, then the customer is not allowed to continue the Lightapp services

A similar approach was to be used when approaching new industrial sites that were not originally contacted during the Recruitment Phase, although new customers would also be required to cover any necessary installation and equipment costs. The WTP would be measured based on the monthly subscription price only, and would not include installation costs.

One critical change between the original WTP design and the final procedure involved the structure of pricing. Asking customers to name a price and compare it to a randomized price, while valid in economic theory, was determined to be infeasible for multiple reasons. First, participant site leadership had no benchmark for this type of service and would not be able to accurately assess the value of the Lightapp software to make an appropriate quote. Other software-as-a-service (SaaS) products were not priced in this manner. Second, pricing for the Blue sites during the Recruitment Phase was determined by the size of the compressed air systems (\$3 per active HP with a 75 percent discount), but the feedback from participant facilities prompted Lightapp to adopt a different pricing methodology. Rather than focus only on system size, Lightapp began integrating multiple factors, such as the number of users, number of data

streams, and access to customized dashboards and reporting, to develop the price for each facility. The facilities and Lightapp were also allowed to engage in price negotiations, as this is considered industry standard practice for SaaS products.

Results

As only 27 of the project sites have completed WTP at the time of this report, all results should be viewed as preliminary.

Participant Take-up

During the recruitment phase, the take-up rate for all eligible industrial facilities with no previous experience using Lightapp or any other EMS was 22 percent (26 percent for the Gold sites and 15 percent for the Blue sites). The hypothesis tested by the first part of the WTP phase was that facilities that have experienced Lightapp (the project participants) would exhibit a higher take-up rate than facilities with no experience. For this report, the take-up rate seen in the recruitment phase was used as the baseline for the latter group, although not enough data were available for a statistical comparison. Future analyses may include take-up information from new industrial facilities not contacted as part of Recruitment, but these data were not available.

Of the 27 project participants that have completed the WTP phase, 11 facilities (41 percent) have decided to continue using Lightapp for a fee, almost double the rate seen for eligible facilities during recruitment. The take-up rates also varied based on whether the sites received Lightapp for free during the treatment period (Gold sites) or paid a discounted rate (Blue sites). Of the 21 Gold sites, eight participants (38 percent) opted to pay for the Lightapp services. Of the six Blue sites, three participants (50 percent) opted to pay for the Lightapp services. Summary numbers can be seen in Table 6.

Table 6: Willingness to Pay Take-Up Results

Sites	Purchased Lightapp	Declined	Total	Percent Purchased
Gold Sites	8	13	21	38%
Blue Sites	3	3	6	50%
All Sites	11	16	27	41%

Source: UC Berkeley

Lightapp Pricing

Although Lightapp changed their pricing model to integrate multiple factors, the size of the participating facility was still the single largest factor affecting the cost of the Lightapp services per horsepower of compressor capacity. To compare evenly between facilities of different size, all prices are represented as dollars per active horsepower (\$/HP) managed. At the beginning of this project and during the recruitment phase,

Lightapp defined their starting price as \$3/HP, and Blue sites paid 75 percent of this fee (\$2.25/HP) during the treatment phase. Gold sites received all Lightapp services free of cost.

On average, the participants that signed on to continue Lightapp services paid \$1.82/HP, a 39 percent decrease from the initial price of \$3/HP. There was considerable variation in the price paid, however, ranging from \$3.78/HP to \$0.66/HP. No difference was seen in the price paid by Gold and Blue sites. When plotting the price paid against the size of the facilities (represented by the active HP), the trend indicates that larger facilities typically paid lower prices per HP and smaller facilities paid higher (Figure 10). The trend line included in the figure is not significant due to the lack of sufficient data points, but is shown to indicate a general logarithmic trend. In addition, including the price points negotiated with sites that ultimately declined to purchase Lightapp (the red circles) demonstrates that pricing does not appear to be the primary basis for facility decisions. Through discussions with project participants, the Lightapp team found that the deadlines imposed by the project, rather than cost, led to some facilities not signing on to continue and expand. Gathering additional data as more sites complete the WTP phase may allow further analysis into these factors.

Figure 10: Lightapp Pricing at Purchased and Declined Sites

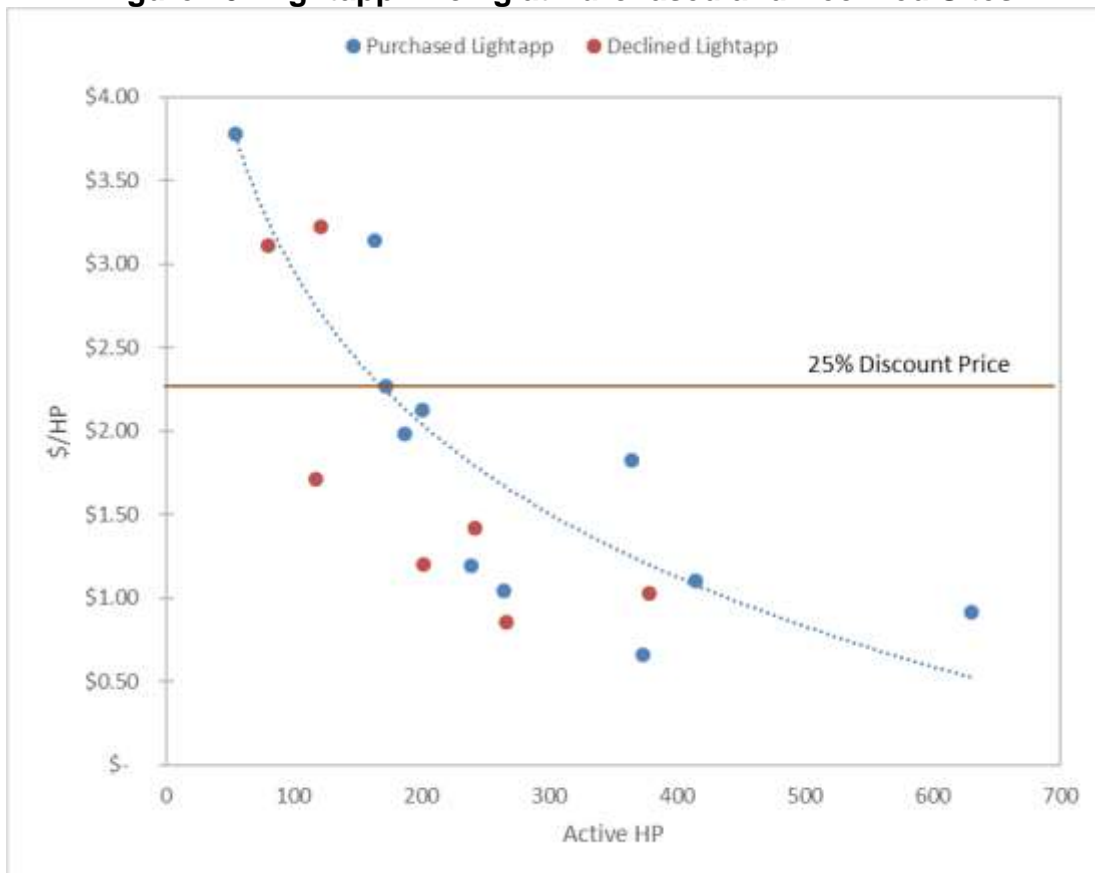

Source: UC Berkeley

Expansion of Lightapp Services

As facilities entered the WTP phase, one of the options available to them was to expand to equipment outside of the compressed air system. Previously, during the Treatment period, individual sites were allowed to expand if the site personnel requested it, but Lightapp was restricted from proactively marketing expansions to keep all of the participants as uniform as possible. Of the 11 sites that opted to purchase Lightapp, five sites (45 percent) also requested to expand into new systems, such as chillers and production equipment. To keep the WTP as accurate as possible, pricing for the expansion was negotiated independently of the compressed air system pricing for this study, although this was not the normal business practice for Lightapp. On average, sites that request expansion paid \$1.98/HP for the compressed air system component, 14 percent more than sites that kept Lightapp only on compressed air with an average of \$1.69/HP.

These results were based on a small portion of all participant sites, and may change in future reports as more data are gathered, particularly in relation to pricing.

Impact on Widespread Commercialization

The Lightapp team identified and adopted new commercialization tactics influenced by the Recruitment and WTP phased of the Engage project. As discussed previously in this report, the first major change was in how the Lightapp team developed pricing for industrial facilities, moving from a static \$/HP number to one that takes plant characteristics into account. By also providing different levels of services, the Lightapp team met each facilities' level of interest in the EMS, providing standard dashboards and reports for some customers at a lower cost and customizing functionality for other customers at a higher cost. The Lightapp team also developed a separate pricing method for multi-site customers, influenced by the participating companies with multiple sites involved in this project.

The results from facilities that have experienced Lightapp suggest that they were more likely to purchase the system compared to facilities without any experience. In response, Lightapp developed a "micro-pilot" program for future customers. The Lightapp team plans to develop a prototype device that can be integrated into all types of meters and sensors by plant staff without the need for specialized training, and this module would be provided to potential customers at no initial cost. The new devices would only connect to a small number of meters or sensors (such as a single compressor or piece of production equipment), but it will allow facilities to experience the Lightapp EMS without requiring significant time or investment. Further details regarding Lightapp's plans for commercialization can be found in Chapter 8 of this report.

Conclusions and Lessons Learned

Although only limited data from the WTP phase were available at the time of this report, the initial findings were consistent with the hypotheses that sites able to experience the Lightapp EMS directly were more likely to purchase the system compared to sites unable to experience it. However, due to the limited number of facilities, the results were not statistically significant and may change as more data are gathered. Completing the Treatment and WTP phases for the remaining 71 participant facilities will prompt more detailed analysis and provide more solid conclusions about the demand for the Lightapp EMS and other industrial energy efficiency technologies.

Through developing the full WTP methodology and engaging with the first 27 participants, Lightapp and the research team have learned several critical lessons in regards to development of pricing and sales tactics for a software-based EMS.

- Flexibility in pricing of the service was critical to meet client needs
 - Keeping a rigid pricing structure with no room for modifications made it difficult to address differences from facility to facility.
 - Pricing that reflects multiple factors, including how the site is using energy and using the Lightapp system, was a better fit than simple \$/HP.
- The biggest competitor to the Lightapp EMS was within-plant spending rather than a competing technology
 - Most facilities fit EMS into an existing maintenance or energy budget, and must justify this spend over other plant projects, such as predictive maintenance and production upgrades.
 - Facilities needed to understand the importance of the energy costs associated with compressed air to find value in an EMS.
 - Many facilities saw other plant systems as more important in relation to cost, such as large chiller systems or production lines.
 - This was an opportunity to expand the EMS into new systems.
- Timing and budget were the two largest factors impacting a facility's interest in an EMS platform
 - Money for maintenance or energy projects was often only allocated during certain times of the year, and the timeline for the project did not always align with the facility's timeline.
 - The labor market for industrial labor was tight, and facility managers often did not have the time or flexibility to invest in new projects.
 - Allowing for both monthly and annual subscription plans also allowed facility managers to draw from either operational expenses or an annual maintenance budget.

- Due to the project structure, the Lightapp team faced several challenges related to project structure:
 - Facilities sometime experienced staff turnover during the Baseline and Treatment periods, so the Lightapp team had to, in effect, sell the entire system again to new employees despite the facility having already received Treatment.
 - Keeping facility personnel engaged for the full Treatment period was also difficult, as many managers prefer to ramp up more quickly, rather than having 11 months before any expansion was allowed.
 - The 90 day deadline also interfered with company procedures involving expenditures, as some can only submit requests on a quarterly or annual basis.

CHAPTER 8:

Technology/Knowledge/Market Transfer Activities

The transfer of the knowledge gained from the Engage project took place in two primary categories: outreach by the research team and scaling up/market adoption activities completed by Lightapp.

Technology and Knowledge Transfer

The knowledge transfer activities targeted audiences who could utilize the Lightapp technology and apply the findings through energy efficiency policymaking and program design. This report details the completed transfer activities and lists the future planned outreach efforts.

Completed Outreach

Multiple Audiences

- The Energy Institute at Haas released a blog post on January 28, 2018 concerning the project and the potential application of the research. The blog was sent to the Energy Institute's distribution list, which consists of about 8,000 email addresses and contains a mix of professionals working in government, energy companies, utilities, academia, and media.
- Presented the project at the 2018 EPIC Symposium (February 7, 2018)
- Presented the project at the Spring 2018 Emerging Technologies Coordinating Council (ETCC) Summit (April 27, 2018)
- Authored article published in the Fall 2018 edition of *California Food Producer* magazine published through the California League of Food Producers (CLFP). The magazine is distributed to food companies and their suppliers across the state.
- Contributed to an article published in *Compressed Air Best Practices*. The article is aimed at industrial energy manager and compressed air installers/technicians.

Industrial Facilities, Trade Organizations, and Installation and Distribution Partners

- As a part of recruitment activities, 1007 potential project participants were contacted and informed about the Lightapp technology and project goals. Of those facilities, dialogue was established with 776 different industrial facilities, all of which either joined the project, declined to participate, or were ineligible for the project. An example of the recruitment material is in the Appendix of this report.

Published Documents

- Catherine Wolfram, "[Are We Promoting the Right Kind of Energy Efficiency?](https://energyathaas.wordpress.com/2018/01/29/are-we-promoting-the-right-kind-of-energy-efficiency/)" Energy Institute at Haas Blog (January 29, 2018). Online at <https://energyathaas.wordpress.com/2018/01/29/are-we-promoting-the-right-kind-of-energy-efficiency/>
- Ron Marshall, "[California Energy Commission and Lightapp Cloud-Based Software Begin Monitoring Study](https://www.airbestpractices.com/system-assessments/compressor-controls/california-energy-commission-and-lightapp-cloud-based-software)," Compressed Air Best Practices. Online at <https://www.airbestpractices.com/system-assessments/compressor-controls/california-energy-commission-and-lightapp-cloud-based-software>
- Kathy Nagel and Andrew Campbell, "Merging Research and Industry- Project Engage is Increasing Efficiency through Optimized Energy Management," *California Food Producer* (Fall 2018). The magazine will be published electronically and distributed via email and at the Food Processing Expo (February 12-13, 2019)

Further Planned Outreach

Multiple Audiences

- Project results will be presented in blog posts, working papers, a policy brief, seminars, and conferences as the opportunities arise.
- A research briefing will be held and a presentation on the project results and lessons learned will be included. Senior management from the regulatory agencies and utilities will be invited to attend.
- Paper(s) with project results will be submitted to one or more peer-reviewed academic journals for publication. Publication will reach a wide audience of researchers and is expected to occur after the CEC contract is complete.

Regulators/ Policymakers

- A project results fact sheet and policy brief will be developed and sent to staff at the CEC and CPUC
- The project team will propose a seminar-style presentation at the CEC targeting energy efficiency staff and commissioner advisors
- The project team will propose a seminar-style presentation at the CPUC targeting energy efficiency staff and commissioner advisors

Utilities

- The project team will develop a fact sheet and policy brief discussing the project results and send this to California utilities.

- The project team will propose a seminar-style presentation at SCE and PG&E, focusing on energy efficiency and major industrial account manager teams.
- The project team will reach out to additional California utilities and provide the project fact sheet to any interested parties.

Industrial Facilities, Trade Organizations, and Installation and Distribution Partners

- The project team will develop a fact sheet detailing the project results and make this available to interested industrial facilities, trade organizations, and installation and distribution companies.
- As part of the willingness-to-pay phase of the project, additional industrial facilities within California will be contacted and will be presented the project results. New facilities are planned to be identified in PG&E's and SCE's service territories in spring 2019.
- The project team will propose a meeting with current installation partner Ingersoll-Rand to discuss project results in addition to the fact sheet.

Production Readiness and Market Transfer

As a software platform, there are no manufacturing processes involved. This section describes the scaling up process and market adoption plan. Lightapp had no plans at this time to license its software.

Dated maintenance practices and increasing competition across all manufacturing markets created a common customer need for detailed energy usage data and an accessible way to visualize and act upon the data to stay competitive as a manufacturer. This need was addressed by Lightapp in two ways:

1. Analytic solutions delivered information and insights to the customer
2. Engagement solutions drove action by delivering the right insights to the right stakeholder, galvanizing efforts across a plant or organization

The main purpose of the EMS was to enable energy optimization by acquiring high resolution energy consumption data in real-time, identifying and generating insights from the data (i.e. identify and calculate leakage), and triggering alerts and actions for the facility's staff.

The Lightapp product included the following capabilities:

1. Automatic workflows, real-time monitoring, and fast engagement
 - a. Dynamic plant mapping helped the manufacturers make better decisions by providing insights about the type, location, and distribution of their energy resources and how they were consumed in the plant.

- b. Real-time data helped plant managers and staff become quickly aware of equipment problems and potential leaks
2. Instant dashboards, prebuilt efficiency indicators, and continuous value calculations
 - a. Lightapp measured and verified every action taken to improve performance, and the system published performance improvement and energy cost savings data and shared it in real time with all authorized users.
 - b. These improvements reinforced a culture of continuous improvement in the facility and across organizations.
 - c. Facility executives evaluated the success of Lightapp through tangible cost savings.
3. Operations benchmarking, equipment ratings, and target prioritization
 - a. Pre-built performance indicators with real-time analytics and predictive scenario modeling were used to identify performance gaps and specify actions to improve the energy consumption bottom line.
 - b. Lightapp benchmarks compared the plant's data to industry best practices and the plant's highest performance achievements to date, guiding the plant to optimal performance.

One of the goals of the project was to take Lightapp from a pre-commercial system into full production. This plan shows the current status and future plans for achieving this goal.

Current Status

Throughout the Engage Project, Lightapp gathered feedback from project participants, researchers, and equipment installers. One of the key characteristics of the Lightapp system was that it is technology-agnostic towards both meter types and industrial systems. It could also be deployed on a wide range of manufacturing processes, but for the purposes of this study it was only deployed on the compressed air systems of the participating industrial facilities. To collect the necessary information for the Lightapp platform, data must be gathered from meters and sensors that collect different readings from the compressed air systems. The meters and sensors used in this project were just examples of the types of measurement devices that Lightapp can integrate with. As part of the scaling-up process to systems beyond compressed air, expansion of these meters and data types would be required. Currently, installation of the Lightapp product on an industrial compressed air system utilized the following:

- Electricity (kW) meters- manufactured by Wattnode and Satec
- Air flow and pressure meters- manufactured by CDI
- Communication hubs- manufactured by Moxa and Verizon, with communication services provided by AT&T, Verizon, and T-Mobile

Installations typically took from one to five days and were performed by third party partners. The facility was mapped on the Lightapp platform, then each meter was linked to a site-specific page where facility personnel can review their site data in real time.

The Engage Project already prompted several changes in the initial Lightapp process as the number of participants increased from six during the pilot to the 96 manufacturing plants during the Rollout Phase. Some of the key lessons learned from scaling up from the original handful of sites are:

1. The installation process transitioned from being custom to each plant to becoming a more uniform, widely applicable process. While creating a custom plan for each participant was feasible during the pilot, this was no longer the case during the full-scale rollout.
2. Uniform data collection technology was simpler for maintenance and troubleshooting after installation, and creating a centralized system support network served the participants more effectively than multiple points of contact within Lightapp.
3. Site level messaging should be simple and quick to read, as plant managers needed to be able to immediately understand any problems or recommendations. With a few sites, close personal relationships with plant managers was possible, but as the project scaled up, this was no longer feasible.
4. There were many opportunities for Lightapp beyond compressed air system monitoring, and there was interest among industrial plants for integration with additional systems.

Just as Lightapp already scaled up once during the Engage Project, the next step was to further scale to continue to accommodate current customers, expand to new clients and systems, and push for larger market adoption of the technology.

Currently, 13 project participants signed agreements to continue utilizing Lightapp's services for a fee after the Engage Project finished. Please note that at the time of this report, 27 project participants were given the option of continuing while the remaining sites were still in the active project phases. In addition, five project sites signed agreements to expand the technology beyond their compressed air systems. Additional systems include high pressure compressed air systems, production equipment, boiler systems, chiller systems, and wastewater.

Implementation Plan

The current Lightapp product could be deployed into production; however, several systematic changes were planned to apply the lessons learned from the Engage Project. Several insights from different phases of the project surfaced that were of particular interest to further scaling up to beyond the 96 project sites:

1. Communication devices - uniform, reliable hardware was required for commercialization and for maintaining acceptable service levels for users and customers
2. Scaling Technology - new infrastructure development and architecture was required for the anticipated influx of new users
3. Scaling Operations - as the Lightapp team continued to grow, software tools and new operational processes were required for large-scale operations and engagement assurance.
4. Market and pricing - with the market continuously changing and the scale of customers shifting, new pricing structures were required to meet the needs of large corporate clients and for the expansion to systems beyond compressed air.

Scaling Up: Critical Processes and Lessons Learned

Communication Devices

Standardization of installation was a crucial part of the installation phase that must be considered when bringing a technology such as Lightapp to scale. For example, although the resulting data from different power meters was the same, the programming of such meters and connection parameters varied from meter to meter. This created the need for further training of technicians and drastically increased the complexity of troubleshooting problems post installation and validating data.

There were two aspects of the installation that still need to be addressed for the commercialization of software in the industrial sector:

1. Lack of installed sensors and meters - Only 15 percent of the participating and installed facilities already had hardware installed on premise that could provide relevant data. Sub-metering down to the machine level was uncommon because of the historically high cost of meters, sensors, and advanced software to use such information. This is changing as the cost of meters has been reduced drastically and software is being developed for the complicated and often noisy manufacturing environment.
2. Limited workforce experienced with sensor communications - Although it was common to find electrical engineers that can install meters in a facility, it was less common to find a maintenance technician that had the capability to complete both the physical installation and the connection of data as part of a single process. The current tight labor market made finding this skilled labor even more difficult.

To help remedy these problems, Lightapp has developed plans to create a prototype device to make installation faster and troubleshooting simpler ("zero" configuration). This device would be able to integrate with all types of meters and sensors, and could be installed by plant staff without the need for specialized training. The repairs and

troubleshooting could also be done by the plant team or by the Lightapp support team, rather than requiring outsourcing of repairs.

The overall research, development, testing, and production readiness of this device could be broken into five stages and was projected to take 10 months as follows in Figure 11.

Figure 11: Development of the Lightapp Prototype Communication Device

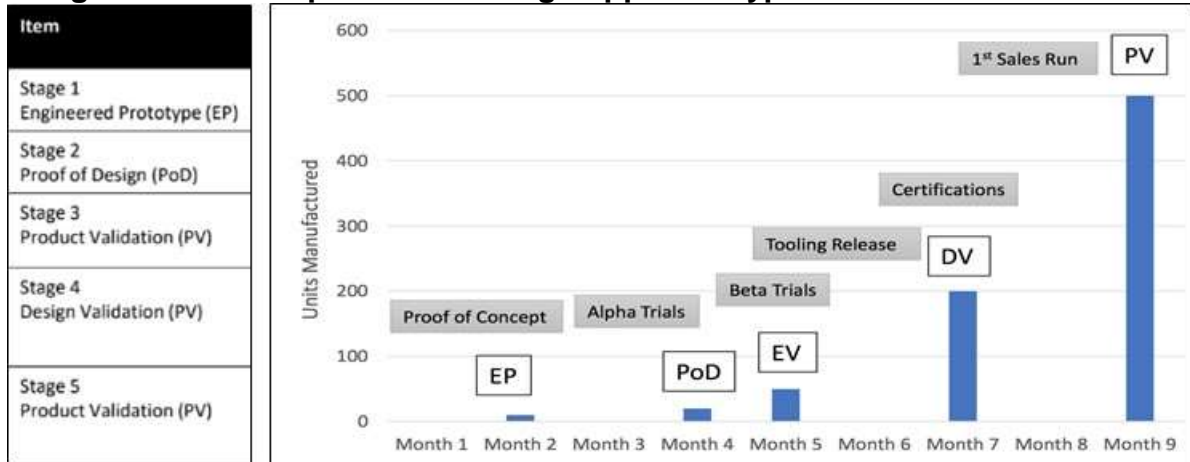

Source: UC Berkeley

It was estimated that the device cost at proof of concept will range from \$3,500-\$5,000 per unit. As production scales up, the cost of devices is expected to decrease significantly.

Scaling Technology

Lightapp's solution was deployed through a stack of four servers as follows:

- Lightapp Energy Data Collector (EDC) - Ran on a Lightapp server hosted by Amazon.
- Lightapp DataGate - served as a generic data collector from client data in multiple formats (including JSON, CSV, and XML).
- Lightapp Internet of Things (IoT) Edge gateway - enabled registration and remote management services for IoT devices. Once a device was registered it starts communicating with the Lightapp DataGate service for data transfer.
- Lightapp Web App server - the front end of the Lightapp Software as a Service (SaaS) offering. Provided the user interface as well as the alerting engine for clients.

Figure 12: The Lightapp Technology Stack

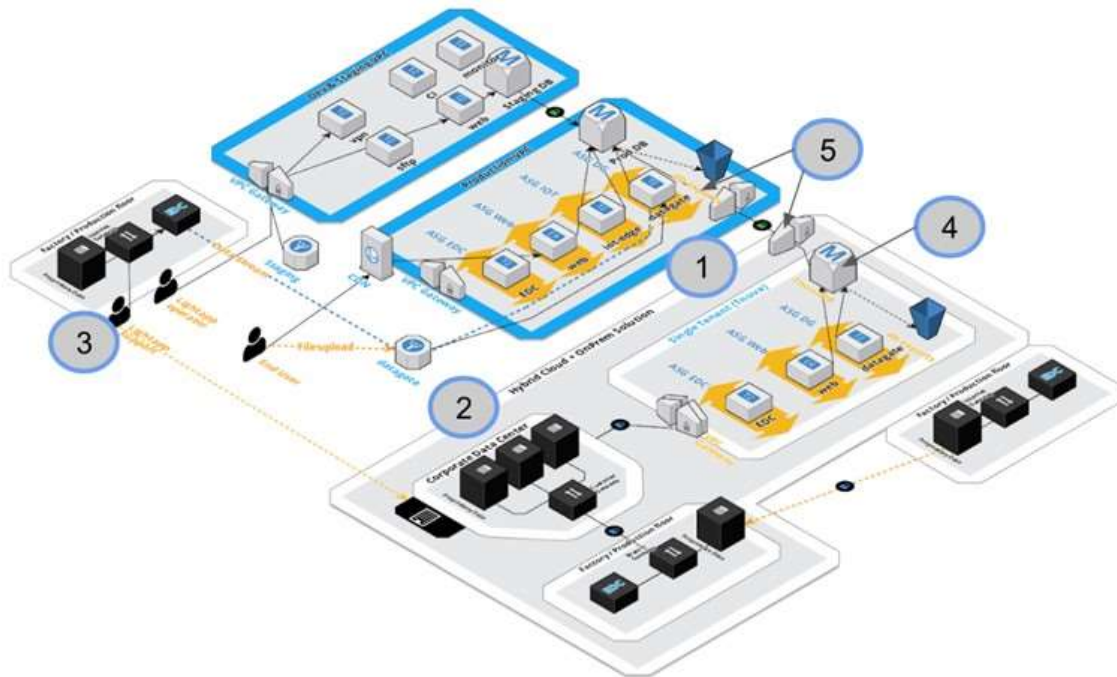

1. A complete dedicated managed SaaS solution
2. Production floor EDC
3. Secure remote Lightapp support for EDC
4. Local database and remote mirror
5. Secure VPC peering for Lightapp analytics platform

Through the project period, newly installed participants sent magnitudes more data to the Lightapp servers, quickly raising the need for a reliable and scalable cloud hosting service.

As customers expanded their deployments to include additional data streams, the data being processed for a single installation alone grows exponentially. These data streams came via additional machines, data historians, programmable control systems, or through an increase in the frequency of data collection from the standard five minutes to more frequent intervals, e.g., one minute or 30 seconds. This required a differentiated approach to architecture and infrastructure providers. Without sufficient cloud hosting services with the right infrastructure, an increase of this magnitude in data could lead to system outages and a significant decrease in system performance.

This increase in data also brought an increase in the problems at installed sites whether they are uncommunicative gateways, broken equipment, or improperly installed meters. At this level it was no longer feasible to address such system maintenance issues with spreadsheets alone. More sophisticated tools were required.

As the scaling continues, Lightapp will identify new tools and processes to best maintain reliable data communication. Lightapp is also developing workflows and sourcing new software tools to identify, track, and prioritize system maintenance.

Scaling Operations

Scaling up customers and technology will require a larger Operations team, and this will expand as progress is made on the previous two critical processes.

Operations include:

- Development Operations (Dev Ops)
 - Automation of software development tools and infrastructure
 - Quality assurance processes, tools and automation
 - Data security infrastructure and tools
- Supply chain for the sensors and communication devices
 - Management of suppliers and third party vendors (such as installers) and others which enable customer order fulfillment for all issues related to customers other than software services
 - Inventory planning and distribution management
 - Hardware support services including returns/replacement management with customers
- Customer Support Services
 - 1st level support - assisting customers with setup and configuration after go-live (including software access, data acquisition and security support)
 - 2nd level support - assisting customers through the introduction of software integrators and domain experts
 - 3rd level support - correct customer issues due to software malfunctions that require Lightapp development team involvement

Integrating messaging as part of the solution streamlines the customer support process and allows for seamless communication between the Lightapp team and clients (Figure 13). The Operations, Support, and Sales teams will increase as Lightapp scales up based on the demand from customers and partners.

Figure 13: The Lightapp Integrated Messaging Dashboard

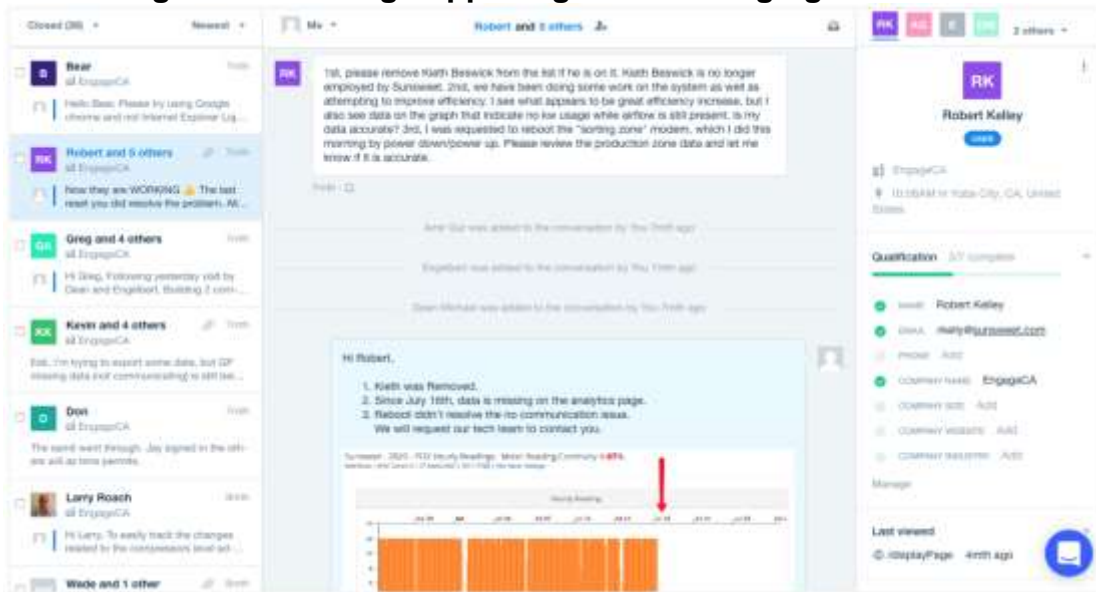

Source: UC Berkeley

Market and Pricing

After the Engage Project ends, the scale of Lightapp's marketing efforts will be increased. Correctly identifying the best markets and ideal pricing for the Lightapp tool is essential to the success of the product, and will continue to be an ongoing challenge throughout the scaling process. Lightapp developed a plan to address these issues through a variety of tactics described.

Market Analysis

Lightapp's market consists of all industrial manufacturing markets. The project found that different markets have different propensities to adopt energy management software. For example, markets with strict environmental regulation, such as mining and cement, are more open to trying energy management software, and markets with low margins such as food and beverage facilities will consider energy management because it can make them more competitive. High margin markets such as technology appear to be less inclined to utilize energy management software.

- The current majority of Lightapp customers are members of the food and beverage industries.
- Other relevant markets in which Lightapp is currently deployed are aerospace, pulp and paper, steel, rubber, plastics, and cement.

Market analysis will continue as more customers and new production systems are recruited, particularly as Lightapp expands beyond compressed air. Integration of different production systems may attract different types of industrial markets, and this information will be monitored and tracked on an ongoing basis to keep up with changing market conditions.

Competitive Positioning

Lightapp's two primary competitors:

- Direct and indirect competition from Software as a Service (SaaS) companies that offer industrial data analytics: Sight Machine, Relayr, Oden, Uptake, C3iot, and EcoPlant. Some offer energy specific data insights, but most are generalized Internet of Things (IoT) solutions that do not address energy usage.
 - *Lightapp's advantage:* Unlike competing software, Lightapp is uniquely positioned as a manufacturing specific solution that optimizes production through the lens of energy management.
- Indirect competition from customers' other budget priorities: many companies perceive Lightapp as a maintenance cost, which pits Lightapp against non-negotiable expenses like equipment repairs and replacement. Organizations have difficulty in allocating budget for energy management software at certain times of year and sometimes are forced to pull from operational expense budgets.
 - *Lightapp's advantage:* As deployments increase and deepen, Lightapp will prove to be not just a supplementary maintenance tool but a necessary competitive advantage. Marketing Lightapp as such will be critical to overcoming this internal competition.

Pricing Strategies

The willingness-to-pay (WTP) phase of the Engage Project provided valuable insight into the demand for the product and the pricing levels most accepted by existing and new customers.

Per site pricing is currently determined through a thirteen point price adjustment tool

- Pricing criteria: users, IoT kits, sensors, data streams, widgets, templates, 3rd party integrations, alerts, and reports.
- Pricing also accounts for company size and energy use.

Multi-site pricing is influenced by the number of sites and the desired functionality of corporate users. The criteria that will affect multi-site pricing:

- Customized dashboards for multi-site supervision and comparison by geography, plant type, plant size, etc.
- The Arena module.
- The per-site pricing will be reduced for multi-site use.

Marketing Mix

Lightapp's market tools included a presence at industry trade shows, partnerships with trade organizations, and articles in trade publications on topics such as compressed air best practices. These outreach efforts will expand as the scaling up process continues.

Trade organization partnerships in particular will help Lightapp scale its marketing efforts due to the large built-in membership base for most of these organizations.

Thanks to the Engage Project, Lightapp obtained many customers in California. While California will continue to be an area of high marketing focus, the scaling up process also includes expansion to new territories and states. As Lightapp expands beyond compressed air, it will continue to leverage these existing relationships and seek new opportunities in a variety of sectors, including boilers/chillers, production equipment, and high pressure systems. Integrating new systems is a critical part of scaling up, and is planned to be an area of greater emphasis as the Engage Project comes to a close.

In addition, marketing automation software such as Marketo may be used to enhance Lightapp's account based digital marketing through emails, mobile messaging, social media, and other digital advertisements.

Conclusions and Lessons Learned

As the Engage Project concludes and the scaling up process continues, Lightapp anticipates more project participants will sign user agreements to continue utilizing its services and software and to expand to additional manufacturing systems. The Lightapp technology has the ability to integrate sensor data from all different types of equipment, and as customers see the value of compressed air monitoring, it is expected they will expand to other systems to maximize savings.

As data continues to be gathered throughout the remaining months of the project, the Engage research team will also continue disseminating the project results to all relevant parties.

CHAPTER 9:

Conclusions/Recommendations

Through the Engage Project, the E2e and Lightapp teams gained insight into industrial energy efficiency technologies and market demand. The goals of the project were to:

- Reduce the electricity used by compressed systems per unit of industrial output.
- Lower operating costs for industrial facilities.
- Evaluate industrial customer demand for a software platform to optimize energy use.

The project team accomplished these goals and identified several key lessons for each objective.

First, for the facilities analyzed so far, annualized energy cost savings are estimated to be more than \$800,000. Given that the Lightapp software can be applied to many industrial systems beyond compressed air, the potential for additional electricity reduction and cost savings is significant.

Second, industrial customer demand for an EMS software platform was high, even when customers had not directly experienced the technology and paid for a monthly subscription fee. Initial take-up during the Recruitment period for eligible sites was 22 percent (26 percent for sites that received the software free of charge and 15 percent for sites charged a monthly subscription fee). After participants experienced the Lightapp technology for 12 months of Treatment, the take-up rate was 41 percent, nearly double the number seen during Recruitment.

Lessons Learned

Throughout the project, the research team identified many important lessons regarding how to take a pre-commercial industrial energy efficiency technology to market, and many of these lessons can be applied to other technologies inside and outside energy efficiency, including:

- Communication to potential customers, particularly industrial facilities, should be simple and straightforward, avoiding buzzwords and focusing instead on tangible benefits to the facility.
- Responsibility for energy was not owned by one uniform position across different companies, and engaging with new sites required flexibility and the use of multiple tools, including LinkedIn, company websites, and phone directories.
- Compressed air service companies were not the most effective channel for recruiting participants, but rather the Lightapp team themselves proved to be much more effective.

- Knowledge about the technology was more important in marketing the product than knowledge about industrial compressed air.
- Keeping participant sites engaged throughout the baseline and treatment periods was vital for success, and communication through multiple lines was the best method for sustaining relationships.
 - Emails, phone call, and in-person meetings were all necessary for successful engagement.
 - Sites left for long periods without communication related to the project were much more difficult to re-engage.
- A customized installation process works for pilot projects, but must be made uniform for the technology to work at scale. Scaling up was a critical step in taking the technology from pre-commercial to fully market-ready.
- Providing customizable software tools to the participants allowed each site to be as engaged or dis-engaged as they chose, and delivering reports focusing only on what was of value to each site team helped site managers to clearly see the value of the technology and how to take the steps necessary for improvement.

Policy Development

The high level of participation in the project by industrial facilities can help inform future policies, projects, and funding for industrial energy efficiency projects. The majority of public energy efficiency funding goes towards residential and commercial programs, but this project demonstrated that significant opportunities remain for industrial programs. The Lightapp technology can also expand beyond compressed air systems, and the methodology followed in this project could be used in the design and execution of similar industrial projects focusing on new aspects of manufacturing systems, such as production equipment or chillers. Policy could accelerate the adoption of EMS technologies by subsidizing an initial trial period, after which more customers would be willing to pay for the technology without subsidies.

The CEC and CPUC could incorporate the RED design used by this research project in the evaluation of future energy efficiency programs. The analytical approach and data gathering techniques can be informative on how to design an RED for a large-scale evaluation and showcase the strength of the results.

CHAPTER 10:

Benefits to Ratepayers

From the beginning, the E2e Engage project focused on the benefits to California investor-owned utilities (IOUs) electricity ratepayers, specifically by enabling industrial and manufacturing facilities to lower their electricity costs. In the short term, this could lead to lower prices for the final goods and materials produced by the participating facilities. In the long run, this project identified industries in which Lightapp's optimization technology was adopted more readily and led to larger electricity cost savings. In addition, the project points toward opportunities to support this technology through IOU-funded energy efficiency programs.

The high level of participation in the project by industrial facilities (22 percent of all eligible plants opted to participate) could help inform future policies, projects, and funding for industrial energy efficiency projects. The majority of public energy efficiency funding goes towards residential and commercial programs, and this project demonstrated that significant opportunities remain for industrial programs. The Lightapp technology could also expand beyond compressed air systems, and the methodology followed in this project could be used in the design and execution of similar industrial project focusing on new aspects of manufacturing systems, such as production equipment or chillers.

Due to the ongoing nature of this research project, all estimates related to specific energy savings based on these results should be viewed as preliminary. Future publications may show different results based on additional data collected since the time of this report.

Quantitative and Qualitative Estimates of Benefits

For the facilities analyzed so far, the annualized impact is:

- 6,292,000 kWh/year in reduced consumption.
- \$812,000/year in lower bills.
- 1,500 tons/year in GHG emissions.

Applying the results to the electricity used by all industrial compressed air systems in PG&E and SCE service territories, electricity ratepayers would see savings of:

- 129,400,000 kWh/year in reduced consumption.
- \$16.5 million/year in lower bills.

- 30,700 tons/year in GHG emissions.

In addition, while this study focused solely on compressed air, the methods used and the underlying technology can be applied to entire industrial systems, not only compressed air systems. Based on the results of the willingness to pay study, many industrial sites showed interest in expanding beyond compressed air after being given the opportunity to experience the technology firsthand. Extending the savings to general industrial energy use could save significantly more:

- 2,587,979,000 kWh/year in reduced consumption.
- \$329 million/year in lower bills.
- 614,300 tons/year of GHG emissions.

This calculation is based on the following assumptions:

- The 2017 industrial customer total electricity use in the territories of PG&E and SCE.⁴
- Considering compressed air systems alone, it was assumed that 50 percent of customers had compressed air systems.
- Compressed air systems consume 10 percent of total electricity use⁵.

The reduced costs can lead to the production of more cost-competitive products by decreasing the per-unit manufacturing cost, as well as lower electricity rates for industrial facilities. The energy savings and operation efficiency that California industrial facilities gained through this project may incentivize facilities to remain in California and make new growth and job creation possible.

⁴ U.S. Energy Information Administration. "Electric power sales, revenue, and energy efficiency Form EIA-861." 2017

⁵ Oak Ridge National Laboratory and Lawrence Berkeley National Laboratory. Prepared by Xenergy, Inc. "Assessment of the Market for Compressed Air Efficiency Services." June 2001. In other countries, such as Australia, compressed air systems also consume 10 percent of total industrial energy use. Sustainability Victoria. "Energy Efficiency Best Practice Guide: Compressed Air Systems." 2009.

REFERENCES

Center for Manufacturing Research. "California Manufacturing Facts." 2018.

Oak Ridge National Laboratory and Lawrence Berkeley National Laboratory. Prepared by Xenergy, Inc. "Assessment of the Market for Compressed Air Efficiency Services." June 2001.

Sustainability Victoria. "Energy Efficiency Best Practice Guide: Compressed Air Systems." 2009.

U.S. Energy Information Administration. "Annual Electric Power Industry Report." 2017

U.S. Energy Information Administration. "California State Profile and Energy Estimates." 2018

U.S. Energy Information Administration. "Electric power sales, revenue, and energy efficiency Form EIA-861." 2017

Wang, Warren. Navigant Consulting, Inc. PIER Industrial, Agricultural, and Water Energy Efficiency Program RD&D Targets: Consolidated Roadmap. California Energy Commission. Publication Number: CEC-500-2011-035, pp. 111-115.

APPENDIX A:

Project Marketing Materials

Talking Points

Goals

- To inform the facility they have been selected
- To inform the facility what the project is and who's involved
- To identify the decision maker and their contact information
- To provide references where the customer can acquire more information about the project
- To schedule a site visit, site survey, and/or installation

Opener

- Hello, I'm <You Name> from <CDA Systems/Osterbauer Compressor Service>.
- I'm calling you about an opportunity for your firm to participate in a large scale demonstration of energy management systems funded by a \$5 million research grant from the California Energy Commission.
- The focus of this project is compressed air systems in California industrial facilities, and the outcome could substantially reduce energy costs for your plant.
- Do you have a few minutes so I can fill you in on the project?

About the project

- Our program is called *Engage*.
- The California Energy Commission has provided a \$5 million dollar research grant to deploy and evaluate an optimizing energy management solution on compressed air systems in 100 industrial facilities across California.
- The idea is very simple. We will equip your compressed air system with meters to monitor energy consumption.
 - The *Engage* software solution gathers highly detailed performance data on your system and delivers analytics and recommendations to improve your energy usage, correct inefficiencies, and troubleshoot any problems in your system.
- The software solution is designed by Lightapp, Inc. – an Industrial Internet of things cloud solution.

- Lightapp delivers continuous improvement and insight into the physical operations of manufacturing facilities, illuminating areas for efficiency improvements and reduced consumption in real-time.
- To encourage participation, the California Energy Commission's funding has enabled us to offer you the hardware and its installation totally free, and access to the software and its services [at a 25 percent discount/totally free, as well].
- If you decide to participate, we will first visit your facility to determine the equipment and the number of meters required for project.
 - We'll also present a participation agreement that outlines the requirements of the project and protects your highly confidential data from third parties.
- If you'd like, I can send you an email with a link to a website and a brief video that explains the project in more detail.

Encountering resistance

- Let me emphasize that this is not a sales pitch.
 - This is a rare opportunity to take advantage of funded, groundbreaking research that will significantly reduce your monthly utility bill without disrupting your operation and at very little cost to you.
- There are more than 50 facilities using Lightapp today.
 - Not only have these plants realized savings between 5 and 27 percent, but customer renewals are running at 100 percent.
- Installation and hardware are totally free *and* you can choose to keep the hardware at the end of the project.
 - This includes up to 3 power meters, up to 2 pressure sensors, one flow meter and all communication devices.
- Being part of this project will be your facility's first step in the new industrial revolution: Industry 4.0
- You will have access to advanced methodologies for energy management and energy best practices.
- By joining this project you will assist groundbreaking research directed by leading researchers - and get the chance to influence key state and federal energy policies.

Eligibility questions

- In order to fulfill the strict research guidelines and rigorous statistical analysis of the study, facilities must meet certain criteria to participate.

- Can I ask you some quick questions to confirm your facility's eligibility?
- The *Engage* project focuses on compressed air systems because they are both extremely common throughout the industrial sector and typically waste an enormous amount of energy.
- Do you have a compressed air system?
 - With how many compressors?
 - To be eligible, you need to have at least two compressors with 100 horsepower each – or three compressors with 60 horsepower each. Can you confirm that your facility meets this requirement?
 - If you have a large system but don't know the horsepower, we can continue for now and confirm the specifics later. A smaller system might affect your eligibility for the project, in which case we wouldn't want to take any more of your time.
- **If they fail to pass** → I'm sorry your plant cannot participate. The research guidelines are very strict and we cannot deviate from them.
 - The researchers, utilities and agencies involved believe the results of this project could potentially have long term implications for industrial energy policy in California and throughout the United States... even globally given California's reputation as a leader in the energy realm.
 - To provide valid data that can be peer reviewed, published and survive public scrutiny, we can only work within the narrowly defined guidelines of target customers.

Role Based Questions

For the Facility Manager

- Is energy consumption and spending on energy a key concern?
- Is reducing energy consumption part of you or your team's performance evaluation?
- Are you able to identify specific processes utilizing compressed air and if they are using energy efficiently?
- Would the proven potential for a 5-27 percent (this number is actually stands for the whole plant, the potential reduction of energy usage of CAS optimization is 10-40 percent) reduction in compressed air energy consumption be enough to warrant further investigation?
- What if I told you that these savings have been validated and are being realized in over 50 manufacturing plants today?

- Would you like to hear about some case studies and maybe a live presentation of the solution?
- Do you believe that there is an opportunity for optimization and cost savings in energy on your shop floor? Are you willing to try and seize this opportunity risk free?
- Are you getting automatic energy reports today? If so, at what level of granularity? Does it make sense to you or would you like it to be verified, analyzed and crunched down to action items and tasks for your teams?
- Do you have, on site or at your headquarters, an “operational excellence” manager?
- Is energy cost or consumption a key performance indicator or (KPI) for the business?

For the facility engineer

- Is energy consumption and spending on energy a key concern?
- Are you able to identify specific processes utilizing compressed air and if they are using energy efficiently?
- Is reducing energy consumption an important operating objective in 2016?
- Is energy cost or consumption a key performance indicator or (KPI) for the business?
- Do you have, on site or at your headquarters, an “operational excellence” manager?
- Is reducing energy consumption part of you or your team’s performance evaluation?
- Would you like to hear about some case studies and maybe a live presentation of the solution?
- Do you believe that there is an opportunity for optimization and cost savings in energy on your shop floor? Are you willing to try and seize this opportunity risk free?
- Are you getting automatic energy reports today? If so, at what level of granularity? Does it make sense to you or would you like it to be verified, analyzed and crunched down to action items and tasks for your teams?

For the Energy Manager or member of the energy team

- Is energy consumption and spending on energy a key concern?
- Are you able to identify specific processes utilizing compressed air and if they are using energy efficiently?

- Is reducing energy consumption an important operating objective in 2016?
- Is energy cost or consumption a key performance indicator or (KPI) for the business?
- Is reducing energy consumption part of you or your team's performance evaluation?
- If you were able to significantly reduce your energy expenses, would your facility qualify for additional financial benefits from your utility?
- How are you reporting your energy consumption today?
- Would you like to try out a smart software tool that will be able to handle the entire reporting for you?
- Do you believe that real time energy analytics driven to key personnel as tasks will be able to make a change on your energy consumption and costs?
- Are today's energy management tasks time consuming at all? If so, would you like to take a look at a tool that can reduce all the tedious work of data collection and normalization and reduce all the data to actionable tasks?
- Do you believe that there is an opportunity for optimization and cost savings in energy on your shop floor? Are you willing to try and seize this opportunity risk free?

For the Chief Operating Officer

- What percentage of your operating budget is taken up by energy costs?
- Is energy consumption and spending on energy a key concern?
- Do you know the biggest energy consuming processes in the plant?
- Does your team have tools in place to understand how energy is consumed and identify opportunities for reduced consumption and cost savings?
- Is reducing energy consumption an important operating objective in 2016?
- Is energy cost or consumption a key performance indicator or (KPI) for the business?
- Are members of your direct or extended team measured on operating efficiency?
- If you were able to significantly reduce your energy expenses, would your facility qualify for additional financial benefits from your utility?
- Would the proven potential for a 5-27 percent reduction in compressed air energy consumption be enough to warrant further investigation?
- What if I told you that these savings have been validated and are being realized in over 50 manufacturing plants today?

- Would you like to hear about some case studies and maybe a live presentation of the solution?
- Do you believe that there is an opportunity for optimization and cost savings in energy on your shop floor? Are you willing to try and seize this opportunity risk free?

For the Chief Financial Officer

- What percentage of your operating budget is taken up by energy costs?
- Are energy consumption and spending on energy a key concern?
- Do you know the biggest energy consuming processes in the plant?
- Does your team have tools in place to understand how energy is consumed and identify opportunities for reduced consumption and cost savings?
- Is reducing energy consumption an important operating objective in 2016?
- Is energy cost or consumption a key performance indicator or (KPI) for the business?
- Are members of your direct or extended team measured on operating efficiency?
- Would the proven potential for a 5-27 percent reduction in compressed air energy consumption be enough to warrant further investigation?
- Do you believe that there is an opportunity for optimization and cost savings in energy on your shop floor? Are you willing to try and seize this opportunity risk free?
- What if I told you that these savings have been validated and are being realized in over 50 manufacturing plants today?
- Are you getting automatic energy reports today? If so at what level of granularity? Does it make sense to you or would you like it to be verified, analyzed and crunched down to action items and tasks for your teams?

Frequently Asked Questions

There are two kinds of FAQs: external and internal. External questions are for publication on the website and other marketing materials; internal questions are not for publication, but written for the sales representatives in case the question is asked.

External

Section 1: Eligibility

1. Is my facility eligible to participate?
 - Participation is by invitation only.

- Invitations are non-transferable and for a specific company at a specific location.
 - Company locations other than those identified on our invitation list are not eligible for the *Engage* research project.
2. Is my compressed air system large enough?
- The project is targeting relatively large industrial facilities with high operating costs.
 - For this project, participating facilities must have compressed air systems with at least two compressors of 100 horsepower each, or at least three compressors of 60 horsepower each.

Section 2: Benefits of Joining

1. What's in it for me? Why should I join?
- The opportunity to significantly lower your electricity costs through a subsidized program.
 - This software will recommend ways to reduce *per product* electricity usage in your facility.
 - Some facilities have utilized this technology to reduce their compressed air electricity consumption by as much as 39 percent.
 - Lightapp continually monitor your facility's compressed air system and provides actionable data that you can use to improve business processes and reduce energy consumption and expense.
 - Your team can use this information to prioritize how and when to make changes and improvements in your plant.
 - By regularly monitoring the Lightapp data, you will be able to identify and address ways to reduce energy waste and save money.
 - You will also experience a risk-free example of how the Industrial Internet of Things is transforming Industrial solutions with real-time data.
 - This is an opportunity to participate in the first-ever randomized evaluation of an industrial energy efficient technology.
 - Since most energy efficiency research has been conducted at the residential level, there is very little existing data or literature for the industrial sector.
 - This project will be the first of its kind to begin building empirical evidence and we expect the results to help initiate a transformation of industrial energy consumption.

2. What are the services I'll receive?

- You will have access to highly granular data on your compressed air system's performance, as well as benchmarks comparing your system's efficiency to standards in your industry.
 - This data will be used to analyze how your facility is producing and using its compressed air resources.
- You will then receive the results of the analysis via reports and dashboards that include automatic recommendations for actions and insights into cost reduction.
- The research program will capture the actions that you take based upon those recommendations, and the results will be presented back to you for tracking and to enable a process of continuous improvement in your facility.
- Example software modules that will be implemented in this project include:
 - An advanced mapping tool for recording metadata and data streams of your compressed air systems
 - Compressed air production efficiency
 - Air compressor efficiency analysis
 - Real-time parameters like pressure and flow
 - Continuous leak detection analysis
 - Idle time costs analysis
 - Insights and recommendations for actions

3. How much should I expect to save?

- Lightapp's best industrial users have experienced reductions of up to 39 percent on their compressed air energy usage.
- Your savings will depend on how much you interact with the system and the extent to which you act on the recommendations.

Section 3: Participation in the project

1. Will this project disrupt my operation?

- We will coordinate and work with you to minimize any disruptions.
- If you can temporarily operate without compressed air or if your facility is already equipped with the necessary monitoring hardware, we can complete the installation without interrupting your production.

2. How much does it cost?

- The monitoring hardware and installation included in the standard *Engage* package is covered by the research grant, so there is no cost to you.
 - The cost of the Lightapp analytics is also subsidized.
 - Your *Engage* account representative can discuss specific costs associated with the Lightapp analytics.
3. How long does installation take?
- In general, installations take about one to three days.
 - Prior to installation, we will conduct a short survey and present an installation plan for your approval.
4. How much of my time will this take?
- We recommend that your facility's energy champion spend 15 minutes a day on the application and meet once a month with the facility's energy team to discuss trends in the Lightapp data.
5. Tell me about the hardware.
- The devices utilized for this project are standard, off-the-shelf commercially available meters.
 - Flow meters, pressure meters, and a power meter are placed on each compressor in your compressed air system.
 - We will also install a secure communications device (similar to a router) that uploads the data to the cloud.
6. Tell me about the application.
- Lightapp is an intuitive, easy to learn, cloud-based application that displays real-time data that you can check anytime, 24/7.
 - The solution is a monitored, highly secure application that resides on Amazon cloud services for the highest standard security and uptime.
 - There is nothing to install on your computer other than one of the common internet browsers.
7. Who will see my data?
- Personnel assigned to your energy team will work with Lightapp to analyze your facility's data.
 - The researchers will use your data strictly for statistical analysis only as part of the statewide research project.

- All data is kept on highly secured infrastructure – either on the researchers’ servers or highly secured Amazon cloud services, in a closed loop system continuously monitored for security purposes.
- No third party may access to your data without your express permission.

8. What are my obligations?

- Facilities that agree to participate must allow the equipment to be installed within a specified 3-month timeframe.
 - Facilities unable to install the equipment during the 3-month window will be ineligible to participate.
- After installation, your facility is required to complete an energy profiling period that will last at least three months, usually no longer than six.
 - While the system is compiling the energy profile, you will not have access to data collected by the Lightapp technology.
 - During the profiling period, you will not hire CDA Systems or Osterbauer Compressor Service to service or repair equipment in your facility unless you are a pre-existing customer with business-as-usual maintenance.
- Once the profile is complete, you can use the data to optimize your system.

9. What’s an energy profiling period and why do I need one?

- The energy profiling period is the startup phase when your facility has installed the monitoring hardware and has begun collecting performance data on your compressed air system.
- This data collection phase identifies the day-to-day energy consumption pattern of your facility before any modifications are made as a result of data gathered or analytics produced by the Lightapp system.
 - By first identifying your facility’s typical energy usage, the research will be able to accurately measure the impacts of the energy management system.

10. What are the next steps if I join?

- First, you would allow our team to visit your facility and survey the site to identify the equipment we’ll need to install.
- Then our team would install pressure meters, flow meters, and power meters on your compressed air system.
- The project then needs to establish the typical energy consumption pattern of your facility. To gather this information, the system will run for at least three months prior to providing data to your facility.

- After this energy profiling period, you'll begin receiving regular reports and recommendations on how to improve your energy usage. You can access granular data online and pursue any or all appropriate corrective actions. By regularly monitoring the Lightapp data, you will be able to identify and address ways to reduce energy waste and save money.
- When the project ends in 2018, you will have the opportunity to continue using the software, and/or apply it to other systems in your facility beyond compressed air.

11. How long is the project and what happens when it ends?

- Each participating facility is expected to receive approximately 12 months of Lightapp system access.
- At the conclusion of the project, you'll have the option to keep the equipment we installed or have it removed at no cost to you.
- You'll also have the option to continue using the Lightapp energy management system for a fee, or even expand it to the rest of your facility.

Section 4: Background

1. What are the objectives of project?

- In order to identify next-generation technologies to meet California's clean energy goals, the California Energy Commission has provided funding to demonstrate the effectiveness of an optimized energy management system on industrial compressed air energy savings.

2. Who is Lightapp?

- Lightapp is a company that offers this software-based, optimized energy management system to industrial facilities.
- Before launching the product in the US, the solution was developed, tested and initially implemented in industrial facilities throughout Israel.
- Lightapp is an industrial Internet of Things cloud solution that delivers unprecedented insight into the physical operations of manufacturing facilities, illuminating areas for efficiency gains and reduced consumption in real-time.

3. Who is CDA Systems?

- CDA is owned and operated by Joe Minichiello. Joe is one of California's most respected compressed air system contractors. With over 24 years in the Clean Dry Air industry and 10 prior years in technical and mechanical experience serving in the United States Coast Guard, he has built a team of skilled and knowledgeable sales and service professionals.

- CDA is built on the “Service Side Up” philosophy. We work with our client’s Technicians and Facilities Managers and meet with CFO’s and CEO’s to further explain the issues or concerns.
 - CDA designs, installs and services compressed air systems and are experts in the air industry throughout California. CDA conceptualized the PLC System now known as ADAS in the early 2000’s using automation and plant controls integration with Altera being the first customer in approximately 2007. Superior knowledge and dedication has helped CDA Systems become the leader in the Clean Dry Air industry.
4. Who is Osterbauer Compressor Service?
- Osterbauer Compressor Service has provided industry with innovative, reliable and cost effective compressed air solutions for over 80 years. As compressed air experts, customers have come to rely on us for a complete range of engineered design, installation and integration of energy efficient systems.
 - Osterbauer’s technical capabilities for designing and maintaining efficient compressed air systems begins with a team of industry experts and our partnership with world class compressed air products, automation, and control solutions. Our turn-key integration services ensure optimal operations of both new and upgraded systems.
5. Why compressed air?
- Compressed air systems were chosen for this project because they are common across all types of industrial facilities and are often inefficient consumers of energy.
 - The Lightapp energy management solution works with many other systems in your plant and you will have the opportunity to consider those options at a later time.
6. Why is it free?
- The project is funded through EPIC, the California Energy Commission’s Electric Program Investment Charge.
 - The CEC awarded \$5 million of EPIC funding through a competitive solicitation process. This funding covers both the cost and installation of monitoring hardware - meters and sensors, and a 12 month subsidy of your subscription to the Lightapp software analytics solution.

Internal

Section 1: Miscellaneous internal questions

1. What’s the catch?

- There is no catch – just opportunity. The California Energy Commission has provided \$5 million to fund this project in order to objectively demonstrate the effectiveness of energy management systems on industrial energy savings.
- In order to participate in the project, there are some minimal obligations your facility has to fulfill, but the potential benefits are enormous – not to mention the metering equipment you'll get for free.

2. What's in it for you?

- The project team believes this is an excellent opportunity for key facilities to receive both access and exposure to a new technology that will soon be an industry standard.
- The academic aspect of this project is designed to better understand the decision-making process around energy efficiency investments.
 - With the understanding that investments in energy efficient technology pay for themselves with energy cost reductions, the research team seeks to understand why don't we see more organizations and leaders pursuing these investments?
- Finally, the California Energy Commission seeks to assess if energy management systems are a viable technology to scale up and incorporate into their industrial energy efficiency programs.

3. Why me?

- The researchers compiled a list of large industrial facilities and assigned each company a random number.
- We have contacted your facility because the random number that was assigned to your facility came up in the selection process.

4. What do you mean I was selected randomly?

- The researchers are conducting a Randomized Controlled Trial – or RCT.
 - It's considered the gold standard for program evaluation because it's the only way to measure the impact that was *caused* by your program, not just *correlated* with it.
- Randomizing the selection process across all eligible facilities in California is extremely important to achieving unbiased results in the evaluation.

5. Will this be public record?

- Data specific to your facility is highly confidential and will not be exposed to the public or third parties without your permission.

- Aggregate results of the *Engage* research project will be reported to the CEC and published in an academic-style paper available to the general public.
6. Who else is participating?
- While we can disclose that only 100 facilities will be recruited, we cannot disclose any information regarding the other industrial customers in the project.
7. Why are the universities involved?
- There's been surprisingly little research into industrial energy efficiency and this project is the first of its kind. It's also the largest known randomized evaluation of industry in the United States.
 - The universities are involved in this project as the independent and objective evaluators to quantify the energy savings that can be attributed to this new technology.
 - The "research" or "study" is the rigorous evaluation of this technology's impact on the energy consumption of your facility.
8. Can our facility be removed from the project after we join?
- No. All of your facility's obligations, as well as those of the partners in the research project, are detailed in a participation agreement that you'll sign when you join.
9. What is the value of the program to our organization?
- Your facility will gain continuous access to granular data and intelligence about the performance of your compressed air system.
 - You will also be able to access detailed recommendations about adjustments and changes that you could make to operations that can produce significant energy efficiency and cost savings—all at little or no cost to the facility.
10. What support do I get from <CDA/Osterbauer>?
- <CDA/Osterbauer> will install the monitoring equipment and provide first level support to participants in the program.
 - Once the profiling period ends, you can contact <CDA/Osterbauer> about making improvements to your compressed air system.
11. What support do I get from Lightapp?
- Lightapp will work with <CDA/Osterbauer> to plan the installation the communication device and ensure that your data is streaming to Lightapp's cloud platform.

- Once the profiling period ends, Lightapp will contact you to begin the engagement process to review how your company can use the data analytics to optimize your system.
 - You will receive regular reports from Lightapp with recommendations for operational changes or low-capital energy efficiency investments that will lower your energy costs.

12. How did <CDA/Osterbauer> become a partner in this project?

- All partners in this project were selected by the researchers and approved by the California Energy Commission through a competitive solicitation process.
- CDA Systems and Osterbauer Compressor Service will install the hardware, Lightapp developed and implements the application, and the researchers conduct the evaluation.

13. How did Lightapp become a partner in this project?

- Lightapp participated in a competitive bidding and evaluation process before being selected by the California Energy Commission as the base technology for this research project.
- Lightapp entered a competition that initially included 27 potential technology solutions.

Section 2: Potential Objections

1. We've invested in energy efficiency before and it hasn't worked out

- Lightapp is much simpler, easier to deploy and use than other energy efficiency investments. Savings are derived from simple, no-cost, no-risk managerial corrections.
- Lightapp has successfully sold and deployed this new technology in a wide variety of industries outside the US and all its customers have experienced significant savings.
 - As a pre-commercial technology in the US, we are able to offer it heavily subsidized as we rigorously calculate the energy savings.

2. We're already energy efficient!

- Many facilities do not have the technology to meter and analyze the performance of individual machines. If you're only metering the net energy consumption for the entire facility, it's not possible to know the operational efficiency specific systems, including your compressed air system.
- Even if you are sub-metering, Lightapp evaluates your energy usage in terms of output.

- For example, this application will show you that Monday, your facility used \$10 worth of compressed air electricity *per widget*; and \$20 on Tuesday; then \$15 on Wednesday.
 - If production is fluctuating, compressed air energy usage should fluctuate as well.
 - The amount of electricity your facility uses on compressed air should correlate directly to the production of your facility. This technology will allow you to optimize that correlation.
3. We just had a leak audit, so we don't need this.
- Leak audits are one-time events and do not provide continuous monitoring like Lightapp.
 - Leak audits never clear 100 percent of the leaks – and leaks always return.
 - Eliminating leaks is just one way to improve your system's efficiency, whereas Lightapp provides many more opportunities for efficiency gains.
 - Lightapp for example will identify the minimum amount of compressed air needed to make your product and then benchmark that performance against similar industry standards.
 - Lightapp provides a dynamic and continuous view of your energy consumption, rather than a static picture of a single moment in time.
4. How do I know this project will not negatively impact my operation?
- Lightapp is a monitoring solution only. It is non-invasive and does not impact the operation of your systems.
 - The meters that will be deployed on your compressed air system are proven, industry standard devices.
 - The staff time required to review the Lightapp data is minimal and shown to be more than paid for by the value and money-saving potential of the data that your facility will receive.
5. What's the failure rate of the equipment and will it cause damage to my operation?
- The monitoring equipment is simple, non-intrusive and reliable, with a very low failure rate.
 - Should any issues arise, the monitors will not impact the operations of your system or effect on your operation in any way.
6. I plan to make changes to my compressed air system. Is that a problem?

- This is not a problem, but we encourage you to consider waiting to make these changes.
 - The data you'll receive through this project will inform you about necessary changes and your expected return on investment from these changes.
7. Who is responsible for the cost of repairs?
- Most of the efficiency gains from the Lightapp technology come from simple, no-cost, non-intrusive corrections to your system, such as when to operate specific compressors in accordance with your operation's demand.
 - The purpose of the Lightapp solution is to provide you with information on how to consume energy more efficiently.
 - Any repairs or capital investment choices that the facility chooses to pursue based on the Lightapp data will be the responsibility of the plant.
8. Can you service my compressed air system while on site?
- The purpose of the profiling period is to identify your facility's typical energy consumption pattern.
 - As a result, no services will be provided until your facility has completed the energy profiling period.
 - Exceptions include repairs for sake of worker safety or business-as-usual maintenance if you have a pre-existing service contract.
9. Will you be accessing my wireless network?
- No. To retrieve the Lightapp data, the project team will install a secure cellular network device that is independent of networks already existing in your facility.
10. Do I need to hire someone new?
- No, but we highly recommend that you identify an energy champion within your facility to manage the application.
11. Why are you selling this? Why not Lightapp?
- We are part of a team effort to deploy and demonstrate the new energy management system developed by Lightapp.
 - Our expertise is in installation and maintenance of compressed air systems, which makes us uniquely qualified to reach out to industrial customers and explain this exciting new opportunity.
12. What happens if my plant goes offline?

- To ensure that the system is gathering the most useful and relevant data, you should notify us if there are any abnormal events that affect plant operations.

13. If this project is funded, why is there a cost to me?

- The CEC funding covers a wide range of expenses related to the project, but not 100 percent of all related costs.
 - The design of the funding model is to remove price as an issue that might reduce the number of participating facilities.

14. How much does the app cost?

- The Lightapp solution pricing for compressed air is based upon a number of factors, such as the size of the compressed air system.
- While the research is focused on compressed air systems, the Lightapp solution works on almost any machine in an industrial setting.
- Before determining a price, the Lightapp account team will work with clients to identify and prioritize what information is required and what components of the facility (or the entire plant) the client wants to measure using Lightapp.

15. What is The E2e Project?

- The E2e Project is a group of economists, engineers, and behavioral scientists focused on understanding the difference between what is technically possible and what is practically achievable for energy efficiency in a wide variety of settings.

Email

Hello, my name is <Your Name> with <CDA Systems/Osterbauer Compressor Service>. We recently contacted you about an incredible opportunity to participate in an energy management demonstration project funded by a \$5 million research grant from the California Energy Commission.

Project overview

The California Energy Commission has provided a \$5 million grant to evaluate an energy management system at only 100 industrial facilities throughout California. Among thousands, your facility has been selected to participate.

We use pressure, flow, and power meters to link your compressed air system's performance to the cloud using a cutting-edge technology developed by Lightapp, Inc.

Why should you participate?

Significant savings: Over 50 facilities outside California have already reduced their compressed air systems' per product energy usage **by up to 40 percent** with this technology.

Low costs, low risks: To encourage participation, the California Energy Commission's funding lets us provide the **hardware and installation for free**.

Industry 4.0: Join the fourth industrial revolution by using this technology and big data to build your company's Industrial Internet of Things.

Fast approaching deadline

The project requires facility registration to be completed as soon as possible.

For more information, visit the [Engage project website](#) where you'll find a brief video and answers to frequently asked questions.

To confirm your plant's eligibility and reserve your spot in the project, please respond to this email or call <Your Number> at your earliest convenience.

Thank you and we hope you will be able to join this exciting project.

<Your Name>

<email signature>

Voicemail Script

Hello, my name is <Your Name> from <CDA Systems/Osterbauer Compressor Service>. I'm calling you about an opportunity to participate in a funded energy management demonstration project for California industrial facilities.

The California Energy Commission has provided \$5 million dollars to evaluate an energy management system at only 100 industrial facilities throughout California. Among thousands, your facility has been selected to participate.

Join the project and your facility will be equipped with an energy management system that will allow you to monitor, manage, and optimize energy consumption – saving you money.

For more information, visit our website at engage.lightapp.com.

To reserve your spot in the project, please call <Your Number> at your earliest convenience. That's <Your Number>. Thank you.

Video Script

- Industrial facilities consume enormous amounts of energy.
- It's a significant cost of doing business.
- Energy is consumed by machines and equipment throughout the facility,
- But it can be difficult to determine if these resources are consumed efficiently.
- Why is that?
- Well, most plants today pay a single utility bill.
- Energy is treated as a single resource that's used for all needs,
- And it's been very difficult to track energy consumption of individual machines or processes.
- So energy waste is invisible,
- And management hasn't had tools to identify where energy is wasted or how to reduce expenses.
- What if you could visualize that wasted energy?
- Get actionable steps on how to improve your operations and processes,
- And significantly reduce your plant's energy expenses?
- All at little or no cost to the facility?
- And finally, what if you could be part of an intensive program
- Funded by the California Energy Commission,
- To evaluate the effectiveness of an exciting industrial energy efficiency solution called Lightapp?
- Welcome to Engage.
- A project whose goal is to evaluate if energy management systems can reduce industrial energy consumption.
- Engage can help you transform your facility from this... to this,
- Helping lower energy costs by operating more efficiently.
- So how does the program work?
- The Engage program is making a limited, one-time offer to participate in this funded, ground-breaking demonstration.
- To be eligible, your facility must be a large consumer of electricity and have a compressed air system.

- If your plant qualifies, expert technicians from our partners, CDA and Osterbauer, will install sensors and meters on your equipment at no cost to you.
- After a startup period for system profiling, Lightapp will begin sending detailed analytics on equipment performance to your energy team.
- Including actionable steps on how to save money by reducing energy consumption.
- You'll also receive data comparing your plant to industry benchmarks.
- At the end of the project, you get to keep all of the equipment that we installed.
- Once you've seen the value of Lightapp, you will have the option to continue and expand the use of the service where it can help in other parts of your facility.
- That's all there is to it.
- So this invitation an incredible one-time opportunity. You have to act immediately to reserve a spot before we offer it to another facility.
- Just respond to the questions in the emailed document.
- We will contact you shortly about next steps.
- Thank you. We hope you join us in this ground-breaking project.

Presentation



Engage

A Funded California-Centric Research Project

*Making Continuous Industrial Energy Management
a Strategic Competitive Advantage*



Participate in a Unique Opportunity

*A Large-Scale Field Demonstration of an Innovative
Industrial Energy Efficiency Program*

- o \$5M funding from the California Energy Commission
- o 100 randomly selected plants in California



How does your facility benefit?

- o Energy and Financial Savings
- o Submeters for your compressed air system
 - Power, pressure, and flow
- o Access to advanced energy management best practices
- o Join the Fourth Industrial Revolution (Industry 4.0)
- o Groundbreaking research
 - Funded by the CEC
 - Results will inform key state and federal energy policies



How does the Program Work?

- o Engage installs all necessary project hardware, including up to:
 - 3 power meters
 - 1 flow meter
 - 2 pressure sensors
 - 1 cellular communications router
- o Energy profiling period
- o Gain access to Lightapp
 - Data analysis, reports and recommendations

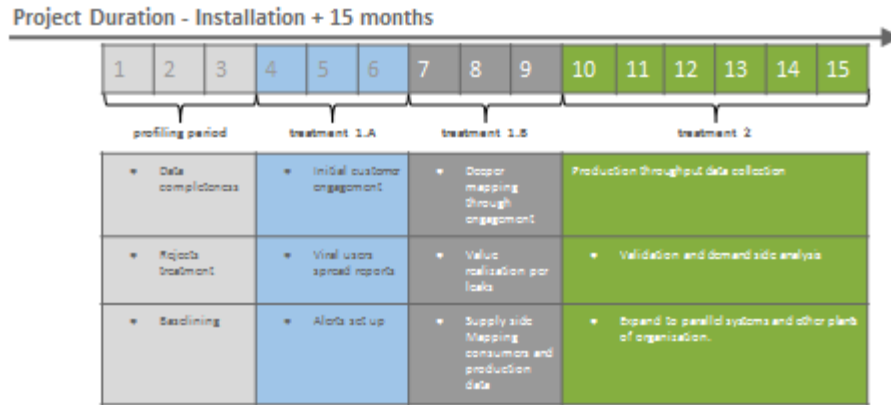

- Scale** *Engage* is the first ever large-scale randomized evaluation of an industrial energy efficient technology
- Scope** *Engage* deploys Lightapp across all types of industries to demonstrate its ability to reduce energy costs
- Rigor** *Engage* results can be attributed directly to the Lightapp technology – not just correlated with it



About Lightapp

Lightapp is an Industrial Internet of Things cloud solution that delivers continuous improvement and insight into the physical operations of manufacturing facilities, illuminating areas for efficiency gains and reduced consumption in real-time.



Proven Technology

More than 50 customers effectively manage their energy resources in real-time.



Join the Fourth Industrial Revolution

- o Smart factories
- o Industry 4.0
- o Industrial Internet of Things

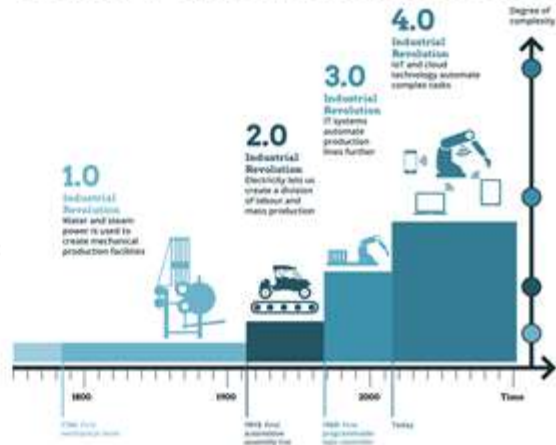

"The disruptive technologies – cloud + mobile computing; sensors + big data (the Internet of Things); machine learning + artificial intelligence; advanced robotics + drones – are driving a new industrial revolution that is rewriting the rules of the 21st century corporation."

Fortune Global Forum – November 2nd, 2015



Included Hardware & Installation



Power Meters

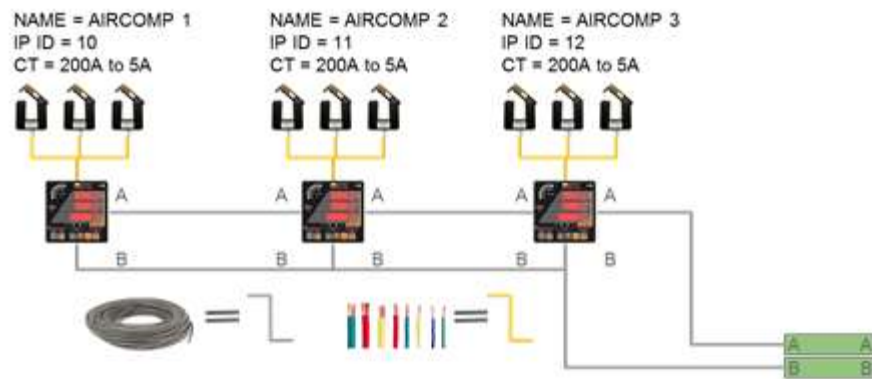



Flow & Pressure

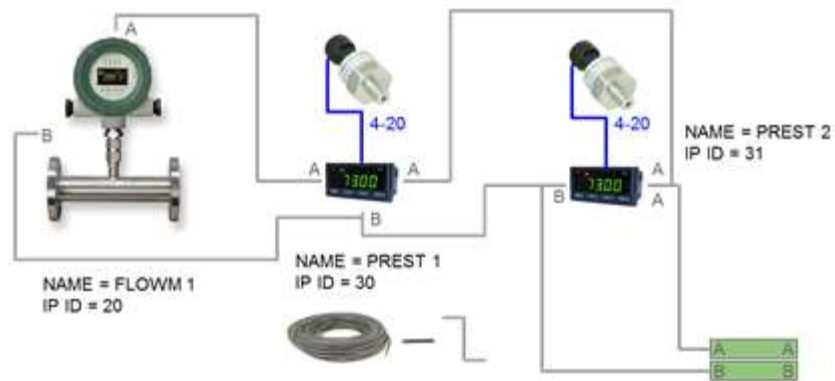

Communications

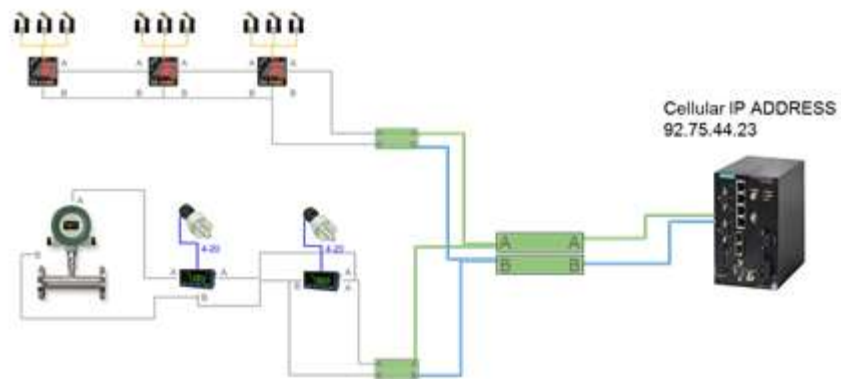

Configuration: Electricity Meter

Quantify system baseload while the factory is not operating



~ \$183,000 annual compressed air system waste

Configuration: Electricity Meter & Production Data

Identify best and worst case levels of energy intensity



In this case, 100% difference between days

Configuration: Electricity Meter, Flow Meter, & Production Data

KPI – kWh/10 CFM (@ specific pressure)
Enables compressed air array optimization

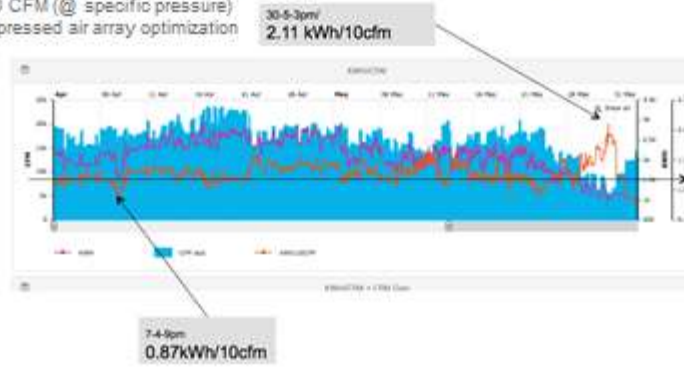

- o Survey your compressed air system
- o Review the participation agreement
- o Schedule the installation
- o *Engage!*

Participation Agreement

Between:

The E2e Project (E2e)

And:

Participants of the *Engage* Project

The purpose of this agreement is to specify the eligibility and participation requirements of your facility and the deliverables of E2e for the duration of the Engage research project.

The California Energy Commission (CEC) seeks to increase adoption of energy efficient industrial solutions to benefit California industry. The CEC has funded E2e to research the effectiveness of an optimized energy management system designed and provided by Lightapp, Inc. to reduce energy costs of industrial compressed air systems. The system collects data from existing and newly installed electric sub-meters, pressure sensors and flow meters. Lightapp, Inc. then analyzes the data to find opportunities to operate more efficiently. The hardware required for the project (including but not limited to power meters, flow meters, pressure sensors, and associated communications equipment) will be provided and installed by CDA Systems or Osterbauer Compressor Service.

1. Participation in the *Engage* research project is voluntary and by invitation only.
 - a. Invitations are non-transferable and for a specific company at a specific location. Company locations other than that identified by E2e are not eligible for the *Engage* research project.
2. To be eligible to participate in the *Engage* research project, your facility must utilize a compressed air system with at least two compressors of 100hp each or three compressors of 60hp each.
3. Data collected at your facility will be kept confidential with these exceptions:
 - a. The service associated with the Lightapp energy management system requires Lightapp, Inc. to view and analyze the collected data. Lightapp will use the data for the *Engage* project only.
 - b. E2e will have access to Lightapp data for research purposes in the *Engage* project only.
 - c. Contact information acquired from your facility will be used in the context of the *Engage* research project only.
4. Participants of the *Engage* research project will complete a facility mapping process designed by Lightapp, Inc. This process identifies hardware necessary to

implement the Lightapp energy management system to be provided by CDA Systems or Osterbauer Compressor Service.

- a. Any extension of the Lightapp energy management system to machines in your facility other than the compressed air system will not be paid for by the *Engage* research project.
5. Access to the Lightapp energy management system and its data analysis support <is free of charge/will be discounted approximately 25 percent> for the duration of the *Engage* research project.
6. Upon installation, E2e will initiate an energy profiling period to identify your facility's compressed air system's typical electricity consumption pattern. The profiling period will collect the electricity consumption, pressure and flow data through the installed hardware. During this time, your facility:
 - a. Will not have access to the data collected by the Lightapp energy management system or its data analysis support.
 - b. Is not allowed to hire CDA Systems or Osterbauer Compressor Service to service, upgrade, or otherwise change any system in your facility, especially the compressed air system, beyond business-as-usual operations included in pre-existing services agreements.
7. Upon completion of the energy profiling period, your facility will receive access to data collected by the Lightapp energy management system and its data analysis support.
8. Your facility agrees to appoint an energy champion for the duration of the *Engage* research project.
 - a. The energy champion will be the primary point of contact for the *Engage* team.
 - b. The energy champion will establish an energy team to meet on a regular basis to discuss trends in energy performance and make decisions for improvements.
9. Participants are expected to work closely with the *Engage* team to ensure successful project implementation in a timely manner. Participants must:
 - a. Respond promptly to technical and operational issues that interfere with project implementation, especially issues that obstruct the continuous flow of data.
 - b. Report systematic changes to your facility's typical electricity consumption pattern.
 - c. Assist E2e in meeting the project's research objectives.

- d. Allow *Engage* team members access to your facility.
 - e. Refrain from adjusting or uninstalling the hardware associated with the *Engage* project without authorization from Lightapp, Inc., CDA Systems, or Osterbauer Compressor Service.
10. The *Engage* research project is expected to end after your facility has received approximately twelve months of access to the Lightapp energy management system, contingent on funding from the CEC.
- a. Upon notification from E2e that the project has ended, your facility has the option to keep or uninstall the hardware associated with the *Engage* research project free of charge. A facility that keeps the hardware may also choose to maintain access to the Lightapp energy management system and its data analysis support for a subscription fee determined by a price list developed by Lightapp, Inc.
11. Upon project completion, all E2e and facility obligations under the *Engage* research project terminate.

Acknowledge the following points by initialing in the space provided:

- _____ I have read, understand, and agree to the content of this agreement.
- _____ I am authorized and able to enlist my facility in the *Engage* research project.
- _____ I confirm that my facility meets the *Engage* research project eligibility criteria.
- _____ I declare that my facility is participating in the *Engage* research project.

Printed Name: _____ Job Title: _____

Signature: _____ Date: _____

Company Name: _____

Address: _____

Energy Champion: _____ Email: _____

Customer Survey

For the facility decision maker or someone who can answer on their behalf

1. Respondent name
2. Job title
3. Briefly describe your roles and responsibilities in the facility.
4. How long have you worked for this company?
 - a. In this industry?
5. Company name
6. Facility Address
7. NAICS code (if known)
8. Is this your company's headquarters?
 - a. If not, where is your headquarters located?
9. Not including your own, how many other facilities does your company have in California?
 - a. Including California, inside the United States?
 - b. Outside the United States?
10. As a percentage of compressed air generation costs, how much do you expect the Lightapp energy management system will save your facility?
11. Are you going to participate in the *Engage* project?
 - a. If no → What is the primary reason you do not want to join this project?
 - i. I don't think this product will save me enough money to make it worthwhile.
 - ii. It may disrupt my facility's operation.
 - iii. The project will take too much of my employees' time.
 - iv. I've never heard of the company that would supply the software.
 - v. I'd like to join, but it's not a good time right now.
 - vi. My facility already has an energy management system.
 - vii. Other (please elaborate).
12. What does your facility produce?
13. How many production lines does your facility have?

14. Estimate your facility's annual sales.
15. Does your facility have a performance-based reward system for staff?
16. Approximately what percentage of your facility's energy costs is due to compressed air generation?
17. What are the largest users of compressed air in your facility?
 - a. The most sensitive users?
18. Has your facility purchased anything in the past two years to reduce energy costs?
 - a. If yes, please describe what was purchased and what the outcome was for your facility.
19. How important are energy costs in the overall priorities of your facility? *(1-5 scale)*
 - a. Of your job? *(1-5 scale)*
20. In your opinion, how energy efficient is your facility? *(1-5 scale)*
 - a. Your compressed air system? *(1-5 scale)*
21. My company is eager to adopt innovative technologies. *(1-5 agreement scale)*
22. I see *Engage* as an opportunity to improve my management capabilities. *(1-5 agreement scale)*

Account Manager Handout

Demonstrate a software-based energy management system in industrial facilities

The E2e Project (E2e), a joint initiative of the University of California, Berkeley, the Massachusetts Institute of Technology, and the University of Chicago, has been awarded a \$5 million research grant from the California Energy Commission (CEC) to demonstrate how a software-based energy management system can reduce energy use in California industrial facilities. The grant is part of the CEC Electric Program Investment Charge (EPIC) program. The EPIC program aims to accelerate the commercialization of energy efficient industrial processes.

E2e's *Engage* research project will evaluate the effectiveness of an energy management system developed by Lightapp, Inc. on compressed air systems. The system collects data from existing and newly installed electric sub-meters, flow and pressure sensors, and analyzes the data to find opportunities to save energy.

To recruit industrial participants and install the necessary hardware, E2e has partnered with two California compressed air companies: CDA Systems and Osterbauer Compressor Service. Pacific Gas & Electric and Southern California Edison provided the research team a list of industrial customers, on a confidential basis, pursuant to a California Public Utilities Commission order that requires the utilities to share information with academic researchers who are studying energy use.

Lightapp, CDA and Osterbauer are all subcontractors to the University of California.

The goals of the *Engage* project are to:

- Reduce the electricity used by compressed air systems per unit of industrial output
- Lower operating costs for industrial facilities
- Evaluate industrial customer demand for the energy management system to optimize energy use

The *Engage* project has three stages:

- Recruit 100 industrial facilities to install meters and communication devices necessary to implement the Lightapp energy management system (2016).
- Estimate electricity and operating cost savings that result in customer actions based on analytics and recommendations produced by the optimized energy management system (2017-2018).
- Estimate customers' willingness to pay for an optimized energy management system (2018).

Each participant will have access to the Lightapp optimization software and data analysis support for approximately 12 months.

At the end of the project in 2018, participants will be informed that the *Engage* project has ended and reminded that their subsidized access to Lightapp has concluded. Participants will have the option to continue utilizing the energy management system for a subscription fee.

This project aims to generate rigorous and reliable evidence of the effectiveness of an industrial energy management system. If successful, the findings can be used to encourage many more California manufacturers to deploy energy management systems to save energy, lower costs, and reduce their environmental impact. For more information, visit the project website engage.lightapp.com.

APPENDIX B: Statistical Models

Regression Model

$$E_{it} = \beta_0 + \beta_1(EMS)_{it} + \beta_2(Output)_{it} + \sum_{j=1}^4 \beta_{2+j}((Temp)_{it} \times \tau_j) + \sum_{j=1}^4 \beta_{6+j}((Press)_{it} \times \tau_j) + \sum_{j=1}^4 \beta_{10+j}((Hum)_{it} \times \tau_j) + \phi_p + \lambda_i + \gamma_t + \varepsilon_{it}$$

$$C_{im} = \beta_0 + \beta_1(EMS)_{im} + \beta_2(Output)_{im} + \sum_{j=1}^4 \beta_{2+j}((Temp)_{im} \times \tau_j) + \sum_{j=1}^4 \beta_{6+j}((Press)_{im} \times \tau_j) + \sum_{j=1}^4 \beta_{10+j}((Hum)_{im} \times \tau_j) + \phi_p + \lambda_i + \gamma_m + \varepsilon_{im}$$

E_{it} = Total compressor electricity usage of facility i during week t

C_{im} = Compressor-related portion of facility i 's electricity costs in month m

EMS = indicator for access to Lightapp

$Output$ = normalized facility production

$Temp$ = air temperature

$Press$ = air pressure

Hum = humidity

τ = time of day and time of week

λ_i = facility effects

γ_t = effects by week

γ_m = effects by month

ϕ_p = effects by utility service territory and rate

ε_{im} = additional heterogeneous effects

Effect of Engagement

$$E_{it} = \beta_0 + \beta_1(LI)_{it} + \beta_2(Output)_{it} + \sum_{j=1}^4 \beta_{2+j}((Temp)_{it} \times \tau_j) + \sum_{j=1}^4 \beta_{6+j}((Press)_{it} \times \tau_j) + \sum_{j=1}^4 \beta_{10+j}((Hum)_{it} \times \tau_j) + \phi_p + \lambda_i + \gamma_t + \varepsilon_{it}$$

We will estimate $(LI)_{it}$ using the following first-stage regression:

$$(Logins)_{it} = \gamma_0 + \gamma_1(EMS)_{it} + \omega_{it}$$

E_{it} = Total compressor electricity usage of facility i during week t

LI_{it} = number of times facility personnel at facility i logged into Lightapp during week t

τ = time of day and time of week

λ_j = facility effects

γ_t = effects by week

γ_m = effects by month

ϕ_p = effects by utility service territory and rate

ε_{it} = additional heterogeneous effects

Results

The analysis used five different specifications for estimating treatment effects from Lightapp. In all specifications the dependent variable is converted to logs and so coefficient estimates represent the percentage change in outcomes due to Lightapp.

All specifications pool data from each facility, i . Specifications (1) through (4) then use the raw data ($t = 5min$). Specification (5) uses weekly totals of the raw data ($t = week$). For kWh the weekly values are the sum of the kWh in each 5-minute period of that week. Missing values are treated as zero. Please note that for the weekly regressions it is not reasonable to only use weeks containing 100 percent complete 5-minute data (there are very few such weeks). For these results then, only weeks where more than 75 percent of the underlying 5-minute data was complete were used. The estimating equations are of the form shown below, where γ is a set of fixed effects as described in the table.

$$\log(kWh_{it}) = \alpha + \beta Treat_{it} + \gamma + \varepsilon_{it}$$

Addition results were also estimated after imputing missing data. A range of imputing strategies are shown here. When using imputed data an additional $Miss_{it}$ variable was included in the regressions. This is a dummy variable indicating whether an observation was imputed. Please note that for the weekly regressions it is not straightforward how to include the $Miss_{it}$ variable and so this is omitted.