

California Energy Commission

DELEGATE CHIEF BUILDING OFFICIAL (DCBO)

RFQ-23-701

BEST MANAGEMENT PRACTICES GUIDE

Attachment 11

2024



CALIFORNIA

ENERGY COMMISSION

Gavin Newsom., Governor

**CALIFORNIA
ENERGY
COMMISSION**

DISCLAIMER

Staff members of the California Energy Commission prepared this report. As such, it does not necessarily represent the views of the Energy Commission, its employees, or the State of California. The Energy Commission, the State of California, its employees, contractors, and subcontractors make no warrant, express or implied, and assume no legal liability for the information in this report; nor does any party represent that the uses of this information will not infringe upon privately owned rights. This report has not been approved or disapproved by the Energy Commission nor has the Commission passed upon the accuracy or adequacy of the information in this report.

TABLE OF CONTENTS

DCBO - BEST PRACTICES MANUAL	1
1.0 Introduction	1
1.1 Background.....	1
1.2 Intent	2
1.3 Energy Commission’s Third-Party Beneficiary Clause.....	2
2.0 Role of the DCBO.....	3
2.1 Conditions of Certification (COCs).....	3
2.2 California Building Standards Code Compliance.....	4
2.3 Industrial Code Compliance	7
2.4 Document Control and Tracking	8
2.5 Limits of Engineering Document Review.....	8
3.0 Laws Ordinances Regulations and Standards	9
3.1 California Building Standards Code (CBSC).....	9
3.2 Primary Industry Codes – Process Piping Systems	10
3.3 49 CFR Part 192 – Federal Natural Gas Pipeline Regulations	15
3.4 National Fire Protection Association (NFPA) Standards	15
3.5 Other Design-Related Conditions of Certification	15
4.0 Typical Project Responsibilities and Milestones.....	16
4.1 Contracting and the Energy Commission.....	16
4.2 Project Kickoff Meeting	16
4.3 Creation of DCBO Project Website	18
4.4 Initial Document Submittal Review – COC Compliance Assistance	18
4.5 Document Submittal Reviews and Approvals.....	18
4.6 Construction Inspection and COC Compliance Oversight.....	18

4.7	As-Constructed Document Package	18
5.0	Best Practices and Procedure Guidance	19
5.1	Document Submittal and Tracking System.....	20
5.2	Inspection Process	33
5.3	Site Presence	35
6.0	Specific Facility Guidance Issues	37
6.1	Common Issues Observed.....	37
6.2	Avoid Creating Issues.....	38
6.3	Excessive Design Reviews – Seek Energy Commission Input .	38
6.4	Specific Energy Commission Addressed Issues.....	38
	Exhibit 1 – Abbreviations, Terms, and Definitions	39
	Abbreviations and Terms	39
	E2.1 Pre-Fabricated Assemblies (PFAs)	40
	E2.2 Use of Industry Code Recommended Practices	41
	E2.3 Ammonia Storage Tank Requirements – Anhydrous and Aqueous	42
	E2.4 Labeling and Listing – Material Approvals vs. Inspection for Compliance.....	43
	E2.5 Natural Gas Pipeline Regulations and Compressor Building Design.....	43
	E2.6 Construction Oversight – Means and Methods vs. Code Compliance.....	50
	E2.7 Professional Engineer (PE) Stamp Requirements for Out of State PFAs and Process Equipment	51
	E2.8 Generating Plant Start-Up Responsibilities of DCBO’s	52
	E2.9 Practical vs. Hard-Line Approach to Code Interpretation	52
	E2.10 Fire Suppression CFC Compliance – Special Equipment Protection.....	53

E2.11 PE Requirements for Plan Reviewers and DCBO	53
E2.12 Qualification of Steel Fabricators Prior to Start of Work	54
E2.13 Process Piping Hydrostatic Testing	55
E2.14 Chemical Spacing – Setbacks within Plant	55
E2.15 Process Piping Material QA/QC – ASME Code Requirements...	55
E2.16 Turbines, Generators, etc. – Equipment Enclosures.....	56
E2.17 DCBO and Local Fire Authority Having Response Jurisdiction – Interaction.....	56
E2.18 ADA vs. CalOSHA/Federal OSHA Handrails and Platforms	57
E2.19 Liquid Storage	57
E2.20 Temporary Facilities.....	57
E2.21 Consistent Application of Importance Factors	57
E2.22 Seismic and Wind Loading of Wind Turbines.....	59
E2.23 Wind Loading of Solar Collecting Devices	59
E2.24 Solar Electric Generating Stations – Occupancy Category.....	61

DCBO - BEST PRACTICES MANUAL

1.0 Introduction

1.1 Background

The Warren-Alquist Act (Public Resources Code sections 25000 et. seq.) grants the California Energy Commission (Energy Commission) exclusive jurisdiction to review and approve applications for certification (AFCs) and petitions to amend (PTAs) for the construction, operation, modification and eventual closure of:

1. Large thermal power plants (50 megawatts or greater).

The Energy Commission utilizes the California Building Standards Code (CBSC) as its model building code and is responsible for interpretation and enforcement of the CBSC.

Assembly Bill 205 establishes an Opt-in Certification program for eligible non-fossil-fueled power plants, energy storage, and manufacturing and assembly facilities to optionally seek certification (Energy Commission Public Resources Code, Division 15, Chapter 6.2, sections 25545-25545.13; California Code of Regulations, Title 20, Division 2, Chapter 5). The following types of facilities are eligible to apply for Opt-in Certification Program:

2. Solar photovoltaic or terrestrial wind electrical generating power plants (50 MW or greater).
3. Energy storage system (capable of storing 200 megawatt-hours (MWh) or more).
4. A stationary power plant using any source of thermal energy, excluding fossil or nuclear fuels (50 MW or greater).
5. Certain transmission lines associated with these generating and storage facilities.
6. Specified facilities that manufacture or assemble clean energy or storage technologies or related components.

Herein, throughout this document, all of these projects and facilities identified above in lines 1 through 6 will be referred to as "Project". If Energy Commission approves a project, the certification would be in lieu of any permit, certificate, or similar document required by any state, local, or regional agency, or federal agency to the extent permitted by federal law, with some exceptions.

The Energy Commission utilizes the California Building Standards Code (CBSC) as its model building code and is responsible for interpretation and enforcement of the CBSC.

When the Energy Commission authorizes a Project owner to proceed with detailed design and construction, the Energy Commission must select a qualified third-party firm to act on behalf of the Energy Commission as their delegate chief building official

(DCBO). In this capacity, the selected DCBO performs their plan review and construction inspection duties in accordance with the CBSC and the Commission Final Commission Decision for the facility. This document has been prepared to assist the DCBO in executing its duties for the Energy Commission.¹

This guide provides additional Energy Commission expectations in the performance of the contract. The DCBO contractor is expected to follow the guide in performing the work, and failure to do so is considered a material breach of the contract that may result in termination of the contract by the Energy Commission without limiting the Energy Commission's rights or remedies. The contractor may deviate from the guide upon prior written approval by the compliance project manager (CPM) responsible for the project for which the approval was requested or by the compliance office manager. In the event of any conflict or inconsistency between the guide and the scope of work, the scope of work shall control.

Within this document, the California Code of Regulations, Title 24, Parts 1 through 12 is referred herein as the CBSC. This may also include specific reference to the California Building Code (CBC), California Electric Code (CELC), California Plumbing Code (CPC), California Mechanical Code (CMC), and the California Fire Code (CFC) as needed for clarity. Other laws, ordinances, regulations, and standards (LORS) also apply to the design and construction of a typical Project.

Within this document, the term developer refers to the collection of entities and individuals working as a team for the owner of a Project, certified by the Energy Commission, to design and construct a Project and related facilities² within California. This includes the owner, owner's engineer, and owner's construction manager, the engineering firm of record, the construction contractor or contractors, and any other groups or individuals working as an agent of the owner.

1.2 Intent

The intent of these best practices is to promote consistency within the Energy Commission's DCBO resource pool when performing construction document plan reviews and inspections pertaining to the construction of a Project. This document illustrates the best practices and methods expected of all Energy Commission DCBO's.

1.3 Energy Commission's Third-Party Beneficiary Clause

Once selected, the DCBO is required to execute an agreement with the project owner that includes a third-party beneficiary contractual clause, that establishes the requirements of service for the project specific DCBO. This language also defines the authority of the Energy Commission and the duties it delegates to the DCBO. The owner of a Project is required to compensate the DCBO for all work performed for the project

¹ Subsequent sections of this document define the typical DCBO tasks and duties.

² Cal. Code Regs. tit. 20, §1201(r)

on behalf of the Energy Commission as required by the conditions of certification (COCs) contained in the Final Commission Decision.

The DCBO is obligated to perform their duties as a delegate of the Energy Commission, and no contract signed, agreement made, or other negotiated term with the project owner relieves the DCBO from the requirements found in the guidance. The DCBO must present suggested changes/clarifications to the Energy Commission's procedures outlined herein to the Energy Commission prior to implementation by the DCBO. Changes cannot be authorized by the project owner.

2.0 Role of the DCBO

The role of the DCBO extends beyond the responsibilities of a typical building department's chief building official. It is important to remember that the authority given to the DCBO is a delegated authority of the Energy Commission. The Energy Commission does not relinquish that authority and has the final decision authority on all matters relating to the design, construction, and licensing of a jurisdictional Project in California and appurtenant facilities to the first point of interconnection. The Energy Commission has the authority to make final decisions relating to interpretations of the CBSC as may be necessary. As its delegate, the DCBO must abide by any interpretation of the CBSC made by the Energy Commission. In addition, all DCBO team members must be approved by Energy Commission staff including additions or replacement team members.

The following sections define the general roles and responsibilities of the DCBO in the performance of their duties delegated to them by the Energy Commission for a Project.

2.1 Conditions of Certification (COCs)

The COCs define the various design and construction compliance tasks imposed on a Project by the Energy Commission. These tasks may involve the performance of work not typically required by other jurisdictional agencies for other construction projects. The COCs are the compliance road map followed by a Project team; they define how a project is to proceed to completion and subsequently to begin operation. The DCBO will assist the Energy Commission with the compliance oversight of these COCs to ensure that they are completed and documented to the satisfaction of the Energy Commission. The DCBO works directly with an Energy Commission compliance project manager (CPM), an Energy Commission employee of the Siting, Transmission and Environmental Protection (STEP) Division, to ensure the Project complies with all of the COCs identified in the Final Commission Decision for the project. No DCBO has the authority to alter or substitute any COCs.

The DCBO shall provide for a professional safety monitor on site to track compliance with Cal/OSHA regulations and periodically audit safety compliance during both demolition and construction activities, commissioning, and for the hand-off to operational status. The safety monitor shall be selected by, and report directly to, the DCBO. The safety monitor will be responsible for verifying that the project owner's construction safety supervisor implements all appropriate Cal/OSHA and Commission safety requirements. The safety

monitor shall conduct on-site safety inspections during demolition and construction at intervals necessary to fulfill those responsibilities. The safety monitor shall have the authority to issue a stop work order for unsafe conditions found on the work site. The stop work order shall be in writing and given to the construction safety supervisor with the corrective measures required to remedy the unsafe condition(s) before work can resume. The safety monitor will ensure that the corrective actions have been properly taken by the construction safety supervisor before work can resume.

2.2 California Building Standards Code Compliance

The primary role of the DCBO is the enforcement of the CBSC requirements. In this role, the DCBO performs two basic functions. The first function is the review and approval of the construction documents necessary for CBSC compliance. The second function is the observation and inspection of construction components to verify that the as-constructed facilities are consistent with the approved construction documents.

A. Design and Construction Document Review and Approval

A Project owner has the regulatory requirement to submit many documents during the course of the design and construction of a Project. The following list should not be considered all-inclusive but provides a guideline regarding the general nature of the required submittals. The COCs identify any special submittals required of the project owner for site, design, environmental, and other compliance aspects for the proposed Project.

- Any documents defined by the COCs;
- Master drawing list;
- Master specification list;
- Project schedule;
- Monthly progress reports;
- Personnel assignment approvals (engineering, inspection, etc.);
- Storm water pollution prevention plans (SWPPP);
- Oil Spill Prevention, Control, and Countermeasures plans (SPCC – submitted directly to Environmental Protection Agency (EPA) – confirmation of transmittal to DCBO only when thresholds for requirements of 40 CFR Part 112 are met);
- Drawings and supporting calculations for temporary electrical, civil, mechanical, and structural facilities proposed during construction (temporary construction power, fire protection, tent warehouses, etc.);
- Hazardous Materials Management Plan (HMMP) per CFC Chapter 50, Section 5001.5.1;
- Civil drawings and supporting calculations (grading, paving, drainage plan and details, plot plans, etc.);

- Geotechnical investigations and reports;
- Site rainfall/firewater runoff and drainage calculations;
- Structural design (e.g. seismic and wind loading design methods to be employed, site class, importance category, occupancy category, design criteria, etc.) methodology;
- Structural calculations (loading, load combinations, computer modeling input and output reports, etc.);
- Structural drawings (reinforced concrete, rebar details, structural steel, connection details, pipe hangers, platforms, handrails and elevated walkways, stationary cranes, fire protection, component mounting and bracing, etc.);
- Structural coatings specifications (insulation, fire protection, etc.);
- Engineered shoring drawings where required;
- Electrical drawings (one-line, conduit and wiring schedules, termination, duct bank, lighting plan and illumination intensity plans, and miscellaneous details);
- Electrical area classification drawings;
- Electrical calculation (voltage drop, conductor sizing, conduit fills, ground grid sizing, short circuit calculations, etc.);
- Mechanical equipment plans and detail drawings (HVAC systems, fire water pumping/monitoring/sprinkling systems, etc.);
- Fire water main, monitor, sprinkler hydraulic calculations;
- Fire protection system alarm and control system design drawings and calculations;
- Process piping system plan and detail drawings (all submitted to the DCBO but only a sampling will be reviewed as outlined above for the process piping system design process verification – plan and details, piping and instrumentation diagrams, isometric details, etc.);
- High energy process piping systems pipe stress and flexibility analysis (provide a sampling as outlined above for the process piping system design process verification);
- Pressure vessel ASME code certification documentation;
- As-built drawings;
- Pipelines;
- Transmission lines;
- Non-compliance reports (NCR) and resolutions thereof; and
- Monthly status of NCR's will be included in the monthly report.

B. Inspection of Constructed Facilities

The inspection of construction by the DCBO is the primary means of assurance to the Energy Commission that construction is proceeding consistent with approved construction documents. The inspection of construction activities will be performed directly by DCBO personnel or by individuals (special inspectors) contracted by the project owner with direct reporting responsibilities to the project owner and DCBO.

The project owner shall have personnel, or contract with firms and/or individuals that are qualified, and certified special inspectors (if not provided by the DCBO) who shall be responsible for the special inspections required by the CBC, Chapter 17, and Section 1704 Special Inspections. The qualification of an inspector shall be demonstrated by attaining certifications appropriate to his/her review and inspection duties as demonstrated by certification with the American Society of Mechanical Engineers (ASME), National Fire Protection Association (NFPA), American Welding Society (AWS), Institute of Electrical and Electronics Engineers (IEEE), and/or any other nationally-recognized testing and certifications appropriate to the scope of his/her duties. The project owner should create and submit a special inspection plan that identifies these special inspectors and their responsibilities. The DCBO shall review and approve the qualifications of the special inspectors. The project owner shall obtain the approvals of any special inspector prior to commencement of any construction activities where special inspection is required. The special inspectors shall work under the direction of the project owner and DCBO and not the firm contracted to construct the Project or any portion thereof. Special inspections include, but are not limited to, the following types of construction and related quality control/quality assurance testing required by the building code:

- Soil compaction;
- Concrete placement and strength tests;
- Bolts installed in concrete;
- Special moment-resisting concrete frame construction;
- Reinforcing steel and pre-stressing steel tendon installation;
- Structural welding;
- Welding of reinforcing steel in concrete;
- High-strength bolting of structures;
- Structural masonry reinforcement placement and unit placement;
- Reinforced gypsum concrete construction;
- Insulating concrete fill placement;
- Spray-applied fire-resistive material placement;
- Piling, drilled piers and caissons driving and testing;
- Shotcrete placement and strength testing; and
- Special grading, excavation, and filling.

In addition to the CBC required special inspections; the project owner shall perform and document the following additional designated special inspection tasks:

- Welding of ASME piping systems;
- Hydrostatic testing of ASME piping systems;
- Buried pipeline coating defect testing;
- Electrical breaker trip testing;
- Motor winding short circuit testing (high pot testing);
- Conductor insulation resistance/short circuit testing; and
- Fire protection system performance witness/performance testing.

Similar to CBC §1704.2.5.1, special inspections of the prefabricated elements within the above systems are not required where the work is done on the premises of a registered and approved fabricator. Such “approval” must be based upon review of the fabricator’s written procedural and quality control manuals and periodic auditing of fabrication practices by an approved special inspection agency. Upon fabrication completion, the approved fabricator must submit a certificate of compliance to the DCBO stating that the work was performed in accordance with the approved construction document.

The special inspectors shall:

- Be a qualified person who shall demonstrate competence, to the satisfaction of the DCBO, if not directly employed by the DCBO, for inspection of the particular type of construction requiring special or continuous inspection;
- Observe the work assigned for conformance with the DCBO-approved and stamped design drawings and specifications;
- Furnish inspection reports to the DCBO and the engineer of record. All discrepancies shall be brought to the immediate attention of the contractor for correction, then, if uncorrected, to the DCBO and the engineer of record for corrective action [2022 CBC, Chapter 17, Section 1704.2.4, Report Requirements];
- Submit a final signed report to the engineer of record and DCBO, stating whether the work requiring special inspection was, to the best of the inspector’s knowledge, in conformance with the approved plans and specifications and the applicable provisions of the CBSC; and
- A certified welding inspector, certified by the American Welding Society (AWS), and/or American Society of Mechanical Engineers (ASME) as applicable, shall inspect welding performed on-site requiring special inspection (including structural, piping, tanks and pressure vessels).

2.3 Industrial Code Compliance

The design and construction of a typical Project includes many different types of piping systems. These include potable water, reclaimed water, sanitary sewers, storm water, steam, natural gas, ammonia, water, geothermal fluids, and other chemicals. It is important for the DCBO to understand and differentiate between process piping and

building/civil piping systems within the submitted plans and apply the appropriate codes to these systems. Generally, the California Building Codes (including the California Plumbing Code – CPC, and the California Mechanical Code – CMC) involve the DCBO more in the code compliance and quality assurance / quality control (QA/QC) process than the ASME Codes. The language of the ASME codes places no code compliance responsibility in the hands of the DCBO. These industry codes place the code compliance responsibility with the owner. However, the Energy Commission charges the DCBO with more involvement in the industry code plan review and inspection process than most process plant project owners typically encounter. The DCBO should establish a process that fulfills the Energy Commission’s COCs without adding excessively to the project’s mechanical design and inspection efforts. This process should be more of a design and construction QA/QC audit.

A DCBO shall communicate any concerns regarding a project owner’s design and QA/QC process and documentation to the CPM for issue resolution (see also Section 4.2 C).

2.4 Document Control and Tracking

The DCBO must develop an internet-based document submittal system that acts as a portal for the project owner to submit construction documents for DCBO review. All Project document submittals will utilize a system in which the DCBO assigns a unique tracking number to all submittals. This submittal system will be username and password protected to restrict access to the project web site where the document tracking system resides.

2.5 Limits of Engineering Document Review

The DCBO should be mindful that its job is to review plans for code compliance. The DCBO is responsible for making a diligent effort to ensure the project owner’s design is code compliant. As defined in CBC Section 202 – DEFINITIONS, enforcement is the *“diligent effort to secure compliance (with the CBSC), including review of plans and permit applications....”* Webster’s dictionary defines diligent as a constant careful effort. These definitions do not include these words: guarantee, warranty, error-free, over-zealous, or exhaustive. The DCBO must be mindful to be diligent, but not over-zealous in his or her efforts.

The DCBO’s job is not to engineer/design the Project; it is not the responsibility of the DCBO to offer opinions based on the economics of a design, or personal design preferences. It is not the responsibility of the DCBO to become a special design subject matter expert.

“The design of a Project often involves the incorporation of special machines and devices. It is not the Energy Commission’s intent for the DCBO to judge the performance standards of any machines. The DCBO’s focus is on the foundations and anchorages of these machines. It is not the responsibility of the DCBO to determine the loads the machines place on foundations and anchorages but rather to review the specifications used, and calculations performed, by the project owner’s engineer for load distribution on such foundations and anchorages”

When code compliance issues arise, the DCBO may assist the project owner when asked by the project owner to do so. For example, the DCBO may suggest a method to solve a particular code-compliance issue that would comply with the applicable code. The project owner has the flexibility to find other solutions; beyond those suggested by the DCBO provided, if those solutions are code compliant.

3.0 Laws Ordinances Regulations and Standards

A Project, properly designed and constructed, will meet or exceed, the appropriate LORS. These include, but are not limited to, the following:

- American National Standards Institute (ANSI);
- American Petroleum Institute (API);
- American Society for Testing and Materials (ASTM);
- American Society of Civil Engineers (ASCE);
- American Society of Mechanical Engineers (ASME);
- California Building Standards Code (CBSC);
- California Occupational Health, and Safety Administration (Cal/OSHA);
- Environmental Protection Agency (EPA);
- International Electrotechnical Commission (IEC);
- Institute of Electrical and Electronics Engineers (IEEE);
- National Fire Protection Association (NFPA);
- Occupational Safety Health Administration (OSHA); and
- Underwriters Laboratories (UL).

In many respects, a typical Project is more process plant than building structure. The DCBO needs to understand this balance and not overly rely simply on the CBSC as the single guidance document for all aspects of compliance.

3.1 California Building Standards Code (CBSC)

The design and construction of all civil, structural, mechanical (except process piping), electrical, and fire prevention facilities shall comply with the CBSC. The Energy Commission utilizes the 2022 California Code of Regulations, Title 24, Parts 1 through 12, (herein referred to as the CBSC), as their model building code. This Title includes the following code parts and their commonly referenced names:

- Part 1 - California Administrative Code;
- Part 2 - California Building Code (Volumes 1 and 2);
- Part 2.5 - California Residential Code;
- Part 3 - California Electrical Code;
- Part 4 - California Mechanical Code;

- Part 5 - California Plumbing Code;
- Part 6 - California Energy Code;
- Part 7 - no longer in use;
- Part 8 - California Historical Building Code;
- Part 9 - California Fire Code;
- Part 10 - California Existing Building Code (formally - California Code for Building Conservation);
- Part 11 - California Green Building Standards Code (CALGreen); and
- Part 12 - California Reference Standards Code.

Included by reference in these CBSC parts are other applicable engineering LORS. Project-specific LORS required for Energy Commission compliance will be defined within a project's COCs.

3.2 Primary Industry Codes – Process Piping Systems

The design and construction of a typical Project includes many different types of piping systems. These include potable water, reclaimed water, natural gas, steam, hydrogen, sanitary sewers, storm water, etc. Figure 3.2.1 (see page 12) Piping Systems Code Boundaries illustrates the general jurisdictional limits of the various piping codes for typical Project. Exceptions should be handled individually. When a DCBO is unsure of how to classify a piping system, they should contact the Energy Commission's assigned CPM for the project.

The appropriate industry codes utilized for piping systems within a Project design may include:

- American Society of Mechanical Engineers (ASME) B31.1 – Power Piping,
- ASME B31.3 – Process Piping, and/or
- ASME B31.8 – Gas Transmission and Distribution Piping Systems.
- ASME B31.12 – Hydrogen Piping and Pipelines.

Design, review, construction, and inspection of a particular piping system will conform to only one piping code. The potable water, sanitary sewers, storm drains, etc. are jurisdictional to the requirements of the California Plumbing Code (CPC) and California Mechanical Code (CMC). The modern Project includes many different types of process piping systems. These include steam, natural gas, ammonia, water, wastewater injection, hydrogen, and other chemicals, which are jurisdictional to the requirements of ASME B31.1 and B31.3 as, depicted on Figure 3.2.1 – Piping System Code Boundaries.

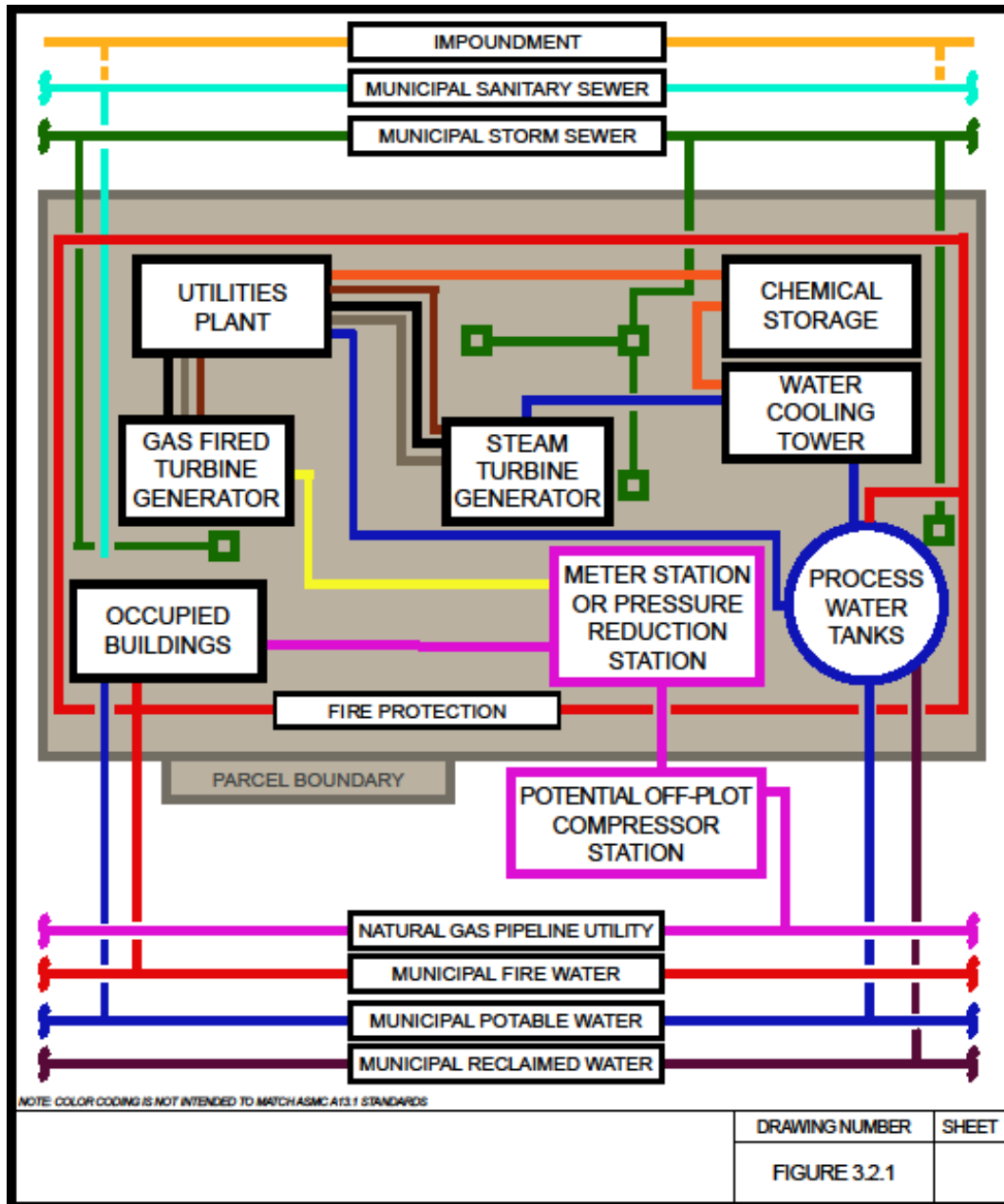

A. ASME B31.1 – Power Piping

ASME B31.1 Power Piping - This code prescribes minimum requirements for the design, materials, fabrication, erection, testing, and inspection of power and auxiliary service piping systems for electric generation stations, industrial institutional plants, and central and district heating plants. The code covers external piping for power boilers operated at high temperature and water boilers operated at high pressure. These vessels typically produce steam (or vapor) at a pressure of more than 15 pounds per square inch gauge (psig). Operating conditions for the high temperature water piping are pressures exceeding 160 psig and/or temperatures exceeding 250 degrees F.

This code addresses high-energy steam piping systems where steam alone is the primary energy source to drive rotating machines. These rotating machines are the drivers for electrical generators.

B. ASME B31.3 – Process Piping

ASME B31.3 Process Piping - The Process Piping Code Section B31.3 has been developed considering piping typically found in petroleum refineries; chemical, pharmaceutical, textile, paper, semiconductor, and cryogenic plants; and related processing plants and terminals. This code prescribes the requirements for materials and components, design, fabrication, assembly, erection, examination, inspection, and testing of piping. This code applies to plant piping for all fluids (not covered by the CBSC or pipeline-related fluids), including: (1) raw, intermediate, and finished chemicals; (2) petroleum products; (3) gas, steam, air, and water; (4) fluidized solids; (5) refrigerants; (6) cryogenic fluids. Also included within the scope of this code is piping which interconnects pieces or stages within a packaged equipment assembly.

This code addresses the more complex plant environment where natural gas, steam, and chemical piping systems are present.

C. ASME B31.8 – Gas Transmission and Distribution Piping Systems

ASME B31.8 Gas Transmission and Distribution Piping Systems - This code covers the design, fabrication, installation, inspection, and testing of pipeline facilities used for the transportation and distribution of gas, including natural gas. This code also covers safety aspects of the operation and maintenance of those facilities. Specifications for gas piping systems can vary depending on jurisdictional control. The DCBO should be aware of which specifications are applicable, as local, state (California Public Utilities Commission (CPUC)) and federal (Federal Energy Regulatory Commission (FERC)) specifications can differ.

D. ASME B31.2 – Fuel Gas Piping

ASME B31.2 Fuel Gas Piping – This Code was withdrawn as an American National Standard on February 19, 1988; however it is still available from ASME as a historical document for reference. This obsolete code is not to be used for the design and construction of current or future Project fuel gas process piping.

E. ASME B31.12 – Hydrogen Piping and Pipelines

ASME B31.12³ is applicable to piping and pipelines handling gaseous hydrogen and gaseous hydrogen mixtures and to piping in liquid hydrogen service. This Code is applicable up to and including the joint connecting the piping to associated pressure vessels and equipment but not to the vessels and equipment themselves. It is applicable to the location and type of support elements but not to the structure to which the support elements are attached. The design for pressure and temperature shall be in

³ <https://www.asme.org/codes-standards/find-codes-standards/b31-12-hydrogen-piping-pipelines/2023/drm-enabled-pdf>

accordance with the requirements of Part IP for industrial piping and Part PL for pipelines.

This Code is presented in the following parts and appendices:

(a) Part GR — General Requirements. Part GR contains requirements applicable to and referenced by other parts. It contains definitions and requirements for materials, welding, brazing, heat treating, forming, testing, inspection, examination, operation, and maintenance. It also contains quality system topics common to the other parts.

(b) Part IP — Industrial Piping. Part IP includes requirements for components, design, fabrication, assembly, erection, inspection, examination, and testing of piping.

(c) Part PL — Pipelines. Part PL sets forth requirements for components, design, installation, and testing of hydrogen pipelines.

(d) Mandatory Appendices I through IX

(e) Nonmandatory Appendices A through F

F. How DCBO Responsibilities Vary Between CBSC and Primary Industry Code Reviews

The Energy Commission charges the DCBO with the authority to ensure that the design and construction of ASME piping systems complies with the proper piping code (as required by the Final Commission Decision and COCs). However, the Energy Commission does not want to add DCBO exhaustive plan check and design review requirements to the existing ASME piping codes. This means that the DCBO should focus on the project owner's overall design and quality assurance processes.

The DCBO design and quality assurance process should include reviews of the following items:

- The DCBO shall review the methods employed by the project owner for high energy piping stress analysis. For ASME piping systems, samples of stress analyses should be reviewed to ensure that the proper methodology and that the stresses comply with codes allowable. This review should investigate the process to be used to evaluate field changes. This should include stress evaluation and documentation work processes.
- The DCBO shall verify that piping design specifications adequately address the operating conditions and ranges of the anticipated process variables (e.g., pressure, temperature, pipe contents, vibration, coatings, material compatibility, etc.). This review should include checks to verify consistency between the specifications, the pipe models, and the design drawings (piping plan and details, isometrics, and piping and instrumentation diagrams).

- The DCBO shall review typical piping drawings (isometric and plan/elevation drawings), supports, etc.
- The DCBO shall review welding procedures, welding procedure qualifications, and welder certifications.
- The DCBO shall review the project owner's process piping QA/QC process (e.g., material procurement, material certifications, material verification during fabrication, weld inspections, etc.) to ensure that the installed process piping systems comply with all design code requirements.

This review will inherently involve a demonstration of competence by the project owner. With demonstrated competence, less frequent and extensive reviews may be required. Identified problems may justify more frequent reviews and oversight.

The DCBO is to perform periodic material QA/QC process checks. No formal submission to the DCBO is required. Records (e.g. mill records and certificates) must be available for DCBO review to ensure that the QA/QC process is resulting in the desired result.

The construction QA/QC process should also be reviewed and periodically checked. Again, there are no formal submissions to the DCBO for welder certifications, welding procedures, and x-ray inspections. However, records must be available for the DCBO's review to ensure code compliance.

The DCBO inspectors should periodically perform field observations of process piping construction to ensure a code compliant system is being constructed. This will provide the Energy Commission with a level of assurance that the systems are code compliant.

This by no means removes the involvement of the DCBO from the process piping design and construction process. It simply modifies the DCBO role for process piping systems to more of an oversight of the project owner's design and construction process (assuming the project owner's QA/QC systems are resulting in code-compliant construction). The DCBO should note and report any process breakdowns or shortcomings to the project owner and the CPM. The DCBO shall follow-up to review process corrections.

Generally, for process piping subject to the ASME codes, this design and construction process review will:

- Eliminate the need for the DCBO to review and approve every process piping drawing and supporting calculations developed for the project,
- Eliminate the need for the project owner to submit for approval copies of all process piping inspection documents (e.g., welding procedures, welding procedure qualification records, welder qualification records, etc.) to the DCBO, and
- Eliminate the need for the project owner to submit for approval copies of all changes to the process piping system.

It is important for the project owner to note that this design process does not eliminate

the need to submit all process piping drawings to the DCBO for record keeping/tracking purposes and to facilitate the overall inspection of the process piping systems.

3.3 49 CFR Part 192 – Federal Natural Gas Pipeline Regulations

Many power generation stations which are designed, constructed, and operated under the jurisdiction of the Energy Commission include natural gas pipelines and compressor station components. The design, construction, operation, inspection and maintenance of natural gas pipelines involves compliance with Federal Pipeline Safety Regulations 49 CFR Part 192 - Transportation of Natural and Other Gas by Pipeline: Minimum Federal Safety Standards. 49 CFR Part 192 incorporates by reference the design, construction, and testing standards of ASME B31.8 – Gas Transmission and Distribution Piping Systems, described above. These regulations and design standards have evolved over the years to improve public safety through improvements in design, integrity assessment, and integrity management. Operations and maintenance plans, and integrity management plans should be in place prior to the start of operations of any natural gas pipeline.

3.4 National Fire Protection Association (NFPA) Standards

The CBSC includes by reference a number of NFPA standards and recommended practices. These include a large number of specialized standards and practices, some of which have no bearing on the design and construction of a Project. Not referenced within the CBSC is the primary fire protection standard for a Project. This standard is NFPA 850 – Recommended Practice for Fire Protection for Electric Generating Plants and High Voltage Direct Current Converter Stations. Within this standard, many of the CBSC referenced NFPA standards are incorporated by reference. The appropriate application of those standards within the Project environment is presented. NFPA should be the primary fire protection standard used within the Project because of unique fire protection requirements of a Project as compared to a typical building structure.

3.5 Other Design-Related Conditions of Certification

COCs vary from project to project. The DCBO must understand this fact and become familiar with the applicable COCs for a particular project. Although not an inclusive list, these COCs typically involve:

- Air Quality: stack height;
- Biological Resources: avian protection measures;
- Hazardous Materials: double-walled piping and tanks;
- Land Use: setbacks, retaining walls, signage;
- Noise: gas compressor enclosure, ACC/rooftop parapet, and other permanent sound walls/screens;
- Soil and Water Resources: SWPPP, recycled water facilities;
- Traffic and Transportation: route and specific design requirements;
- Visual Resources: lighting requirements; and

- Worker Safety and Fire Protection: local fire codes.

The Energy Commission CPM will define the DCBO's involvement, and their compliance oversight responsibilities for compliance with these COCs for each project. The CPM will coordinate with staff by providing staff with project construction information so that staff can make the necessary decision regarding DCBO's involvement.

4.0 Typical Project Responsibilities and Milestones

The following sections describe the typical project milestones for a Project.

4.1 Contracting and the Energy Commission

The involvement of an Energy Commission DCBO begins with the STEP Division's selection process and the subsequent third-party beneficiary clause included in the contracting documents drafted by the selected DCBO and the project owner.

The Energy Commission's third-party beneficiary status does not burden the state with any financial responsibility to the DCBO. The project owner financially compensates a DCBO. The project owner and the DCBO enter into a contractual agreement that defines the scope and compensation of the DCBO. Work performed by the DCBO without a contract is at their risk. It is in the interest of the project owner to finalize a contract with the DCBO as expeditiously as possible to avoid delays.

4.2 Project Kickoff Meeting

All Project projects should include a project kickoff meeting conducted by the Energy Commission early in the project design process. The Energy Commission's CPM schedules and conducts this meeting. The CPM is responsible for developing the agenda. Typically, this project kickoff meeting is held at the Energy Commission headquarters in Sacramento, California. Key members of the Energy Commission, the DCBO, the project owner, and other Federal / State agency stakeholders are invited and encouraged to attend. Key individuals are introduced to provide a face-to-face personal connection intended to foster communication and teamwork. Discussed at this kickoff meeting are high-level issues and the identification⁴ of plans forward. This kickoff meeting can be used to identify potential issue resolution teams.

A. Project Overview

An overview of the project is presented by the CPM and the project owner. Communicated information includes the Project location, size, design basis, special technology, and other general project data. Presented during this discussion are project stakeholder expectations. All attendees have a chance to provide input from their project responsibility perspective. This interaction eliminates surprises during the project. Special

⁴ It is not the intent of the kickoff meeting to resolve all issues, but to identify those issues that require special attention and resolution.

COC compliance issues and timeframes for completion are normally discussed.

B. Roles and Responsibilities

Attendees are briefed regarding the roles and responsibilities of the various groups anticipated to interact during the course of the development of the project. Where perceived overlaps exist, the kickoff meeting provides an opportunity to clarify the scope of responsibilities of each stakeholder. The intent is to clarify vague or undefined stakeholder involvement in an effort to develop a mutual understanding and increase project execution efficiency. It is an opportunity early in the project to communicate expectations and objectives and to resolve any misconceptions by the stakeholders regarding their roles and responsibilities.

C. Timing and Schedule / Critical Path and Conflict Resolution

During the kickoff meeting, both the Energy Commission and the project owner communicate their current work in progress and projected completion timelines. Typically, the kickoff meeting precedes the Energy Commission's notice-to-proceed with site construction efforts, and the COCs typically require a number of pre-construction site mobilization requirements. The pre-construction requirements are discussed at the kickoff meeting so that a critical path can be identified that enables the project owner to plan and schedule construction mobilization.

During this meeting, the project can discuss other critical path issues (once construction site work has commenced) and the impact they may have on the Energy Commission, the DCBO and other agencies. The Energy Commission, DCBO and other agencies can provide feedback to the project owner regarding anticipated timing and possible impediments to timely completion. In the case of the DCBO, any project desired compression of schedule might result in increased labor costs not included in their original contract documents with the project owner. The impact of planned construction schedule compression is best resolved before significant DCBO work begins. The emphasis of the kickoff meeting is information sharing to facilitate project implementation. While the parties are encouraged to resolve potential conflicts independently, if problems persist, or code interpretation is at issue, notify the CPM promptly. The CPM can provide guidance and facilitate the issues informally, or if resolution between the parties remains elusive, the CPM can convene a more formal meeting to seek resolution.

D. Document Submittal Process Review

The DCBO provides an overview of the document submittal process that includes a high-level demonstration of the web-based submittal process. This document submittal process shall be consistent with the Energy Commission's expectation of such a system as defined herein. This review will provide an opportunity to resolve any issues regarding the submittal process before significant numbers of electronic submittals begin.

E. Inspection Performed and Inspection Request Process Review

Similar to the document submittal process review outlined above, the DCBO is

encouraged to review the construction inspection process in place for the project. This includes the methods and timing available to the construction team to request inspections of in-process and completed task work.

4.3 Creation of DCBO Project Website

Upon execution of a contract with the project owner, the DCBO must create an Energy Commission project website. This website is where the Energy Commission accesses documents and reviews project progress. The DCBO selection letter will define the requirements for this password-protected internet website.

4.4 Initial Document Submittal Review – COC Compliance Assistance

The DCBO should be mindful that the Energy Commission might request the DCBO to review some preliminary documents submitted to the Energy Commission as required by the COCs. The DCBO should communicate this to the project owner during their contract negotiations. The amount of time required for this type of work varies from project to project.

4.5 Document Submittal Reviews and Approvals

The bulk of the work performed by the DCBO involves the review of construction drawings, calculations, and other documents supporting the engineering. This work often begins after the execution of a contract. This document review and approval process requires the DCBO to develop an internet-based document management system. This document management system tracks the large number of documents from original submittal to the as-constructed stage of the project. A detailed description of the Energy Commission's expectations for a document management system is included in this guidance document. The DCBO should anticipate concurrent document submittals with ongoing construction.

4.6 Construction Inspection and COC Compliance Oversight

The DCBO shall conduct field inspection and Energy Commission COC compliance oversight. In this role, the DCBO is responsible for the inspection of constructed facilities to ensure compliance with the approved construction drawings. The DCBO inspectors ensure that the DCBO plan review team approves all construction documents prior to use in the field. Construction should not proceed without stamped "approved for construction" drawings. The DCBO inspection team is responsible for the oversight of the special inspections performed by the project owner. This includes the oversight of the recordkeeping of the special inspectors.

There are tasks not typically performed by building departments inspectors that are a part of the Energy Commission DCBO responsibilities. These involve compliance items identified within the COCs, which are listed in this document.

4.7 As-Constructed Document Package

The final task performed by the DCBO is the oversight/development of the as-

constructed, or as-built, document package. The submittal of the as-constructed document package to the Energy Commission is for document archival purposes as required by the COC's. This is an electronic file-based submittal, typically submitted on compact disk (or DVD) media in an Adobe Acrobat PDF file format.

The as-constructed drawings originate from redlined construction drawings. The project development team at the Project site maintains the redlined drawings. The DCBO construction inspectors ensure that the project development team captures field changes. The DCBO will receive the revised construction drawings from the project development team's Engineer of Record and combine them with the project supporting documents to create the as-constructed document package. The supporting documents include, but are not limited to the following:

- Construction drawings;
- Supporting calculations;
- Construction specifications;
- Inspection records;
- Special inspection records; and
- Worker safety records, etc.

The files should be organized on the CD/DVD by COC section:

- General - GEN;
- Civil – CIVIL;
- Structural – STRUC;
- Mechanical – MECH;
- Electrical – ELEC.
- Transmission Systems Engineering– TSE.

The DCBO is responsible for verifying the completeness of this package, which should include any additional linear facilities within the Energy Commission's jurisdiction that are not included in the above six facility design engineering disciplines. The Energy Commission receives one copy, a second is transmitted to the owner.

5.0 Best Practices and Procedure Guidance

This section focuses on the tasks associated with the document / plan review and inspection aspects of the DCBO's responsibilities. The development of a Project typically involves concurrent design and construction efforts. Grading and site plans (or other preliminary civil works) are typically the first designs submitted for review and approval. Once approved, civil site construction work begins. Foundation designs and detailed site underground utility designs follow next. Some time may pass before process piping and electrical designs arrive at the DCBO for review. It may also be some time after a design review commences that actual construction requires a significant inspection staff on-site. This "fast track" design and construction process requires well-organized

processes in place to track all submittals in their various stages of development.

It is an important practice to prepare well-documented review comments. This aids the project owner. First, significant time may pass between subsequent submittals of the same package. As a result, well-documented comments, citing CBSC specific sections, paragraphs, and tables, eliminate the project owner's reliance on his team's memory to effectively respond to specific DCBO submittal comments. Second, detailed comments provide better directives for code compliance. Well-documented comments substantiate specific non-code compliance observations by the DCBO and eliminate issues relating to opinions vs. facts.

5.1 Document Submittal and Tracking System

The DCBO's document submittal and tracking system shall be an internet / website-based electronic process where the hardcopy transmittals of documents are minimal. As stated in Section 2.4, this system will be username and password protected to restrict access to submittals. The submittal and tracking process must provide submittal associative links to review comments, approvals, inspection requests, and construction approvals. The tracking system must possess a multi-level file structure that organizes the submittals by:

- Section within the COC requiring the submittal,
- Chronological order and date of the submittal,
- Approval status of the submittal including partial approvals,
- Time anticipated for completion of the DCBO's review,
- Document review comments,
- Subsequent re-submittal of the corrected documents,
- Approved by the DCBO and availability (for printing with DCBO approval stamp affixed) for construction,
- Construction inspection requests, and
- Inspection comments, rejections and approvals.

Minor variations to the structure offered herein may be acceptable if approved by the Energy Commission prior to the start of a project. Alternative methods of saving documents within a traditional multilevel file structure are acceptable, provided they function in a similar manner. Database (document) tracking systems are acceptable, provided they are organized with a search engine that locates submittals / documents in the same logical fashion as would be done within a traditional data file-server structure.

Figure 5.1.1 – Document Tracking System File Structure that follows graphically depicts the file structure required by this section.

Figure 5.1.1 – Document Tracking System File Structure

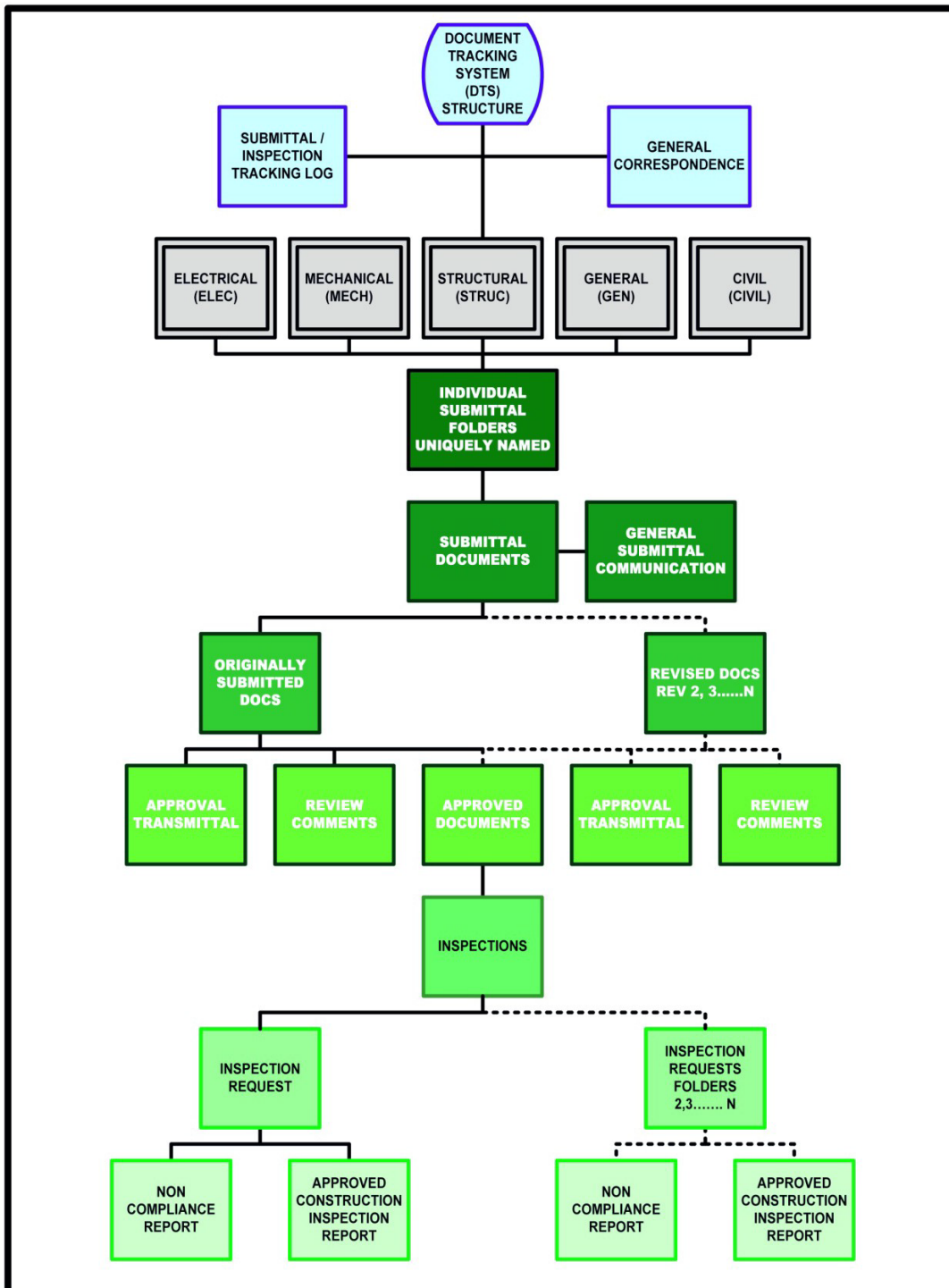

A. DCBO Work Process

The tasks involved in the day-to-day work functions of a DCBO should follow a logical and consistent step process. It is not the intent of this guideline to restrict the creativity, nor limit potential efficiency improvements, of any DCBO processes. The Energy Commission does not intend to restrict the methods and systems used to create an efficient document tracking system.

The DCBO's work process should follow the steps outlined in the following flow charts. Figure 5.1.2 – DCBO Work Process Flow Chart (seven pages) that follows provides a graphical depiction of the typical work process from the project owner's document submittal through the development of the "as-constructed" document package.

Figure 5.1.2 – DCBO Work Process Flow Chart

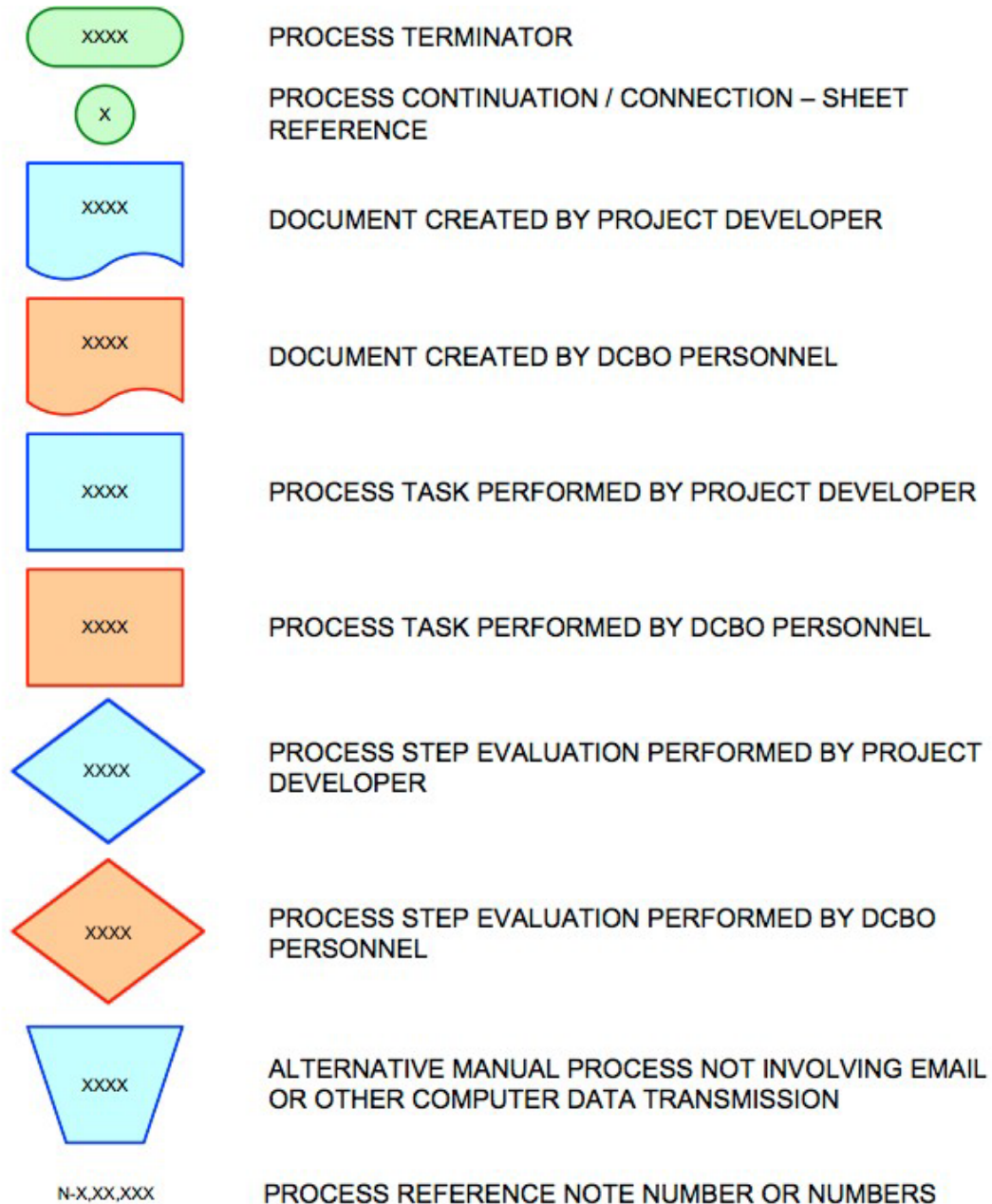

SYMBOLS LEGEND

ABBREVIATIONS USED IN THIS DOCUMENT

ACDP – AS CONSTRUCTED DOCUMENT PACKAGE
 CBC – CALIFORNIA BUILDING CODE
 CEC – CALIFORNIA ENERGY COMMISSION
 COC – CONDITIONS OF CERTIFICATION
 DCBO – DELEGATE CHIEF BUILDING OFFICIAL
 DCM – DOCUMENT CONTROL MANAGER (DCBO)

DOCS – SUBMITTED DOCUMENTS TO DCBO FOR REVIEW
 DTN – DOCUMENT TRACKING NUMBER
 DTS – DOCUMENT TRACKING SYSTEM
 N-“X” - NOTE REFERENCE NUMBER SHOWN ON CHART
 LORS – LAWS, ORDINANCES, REGULATIONS, AND STANDARDS
 PD – PROJECT DEVELOPER / OWNER

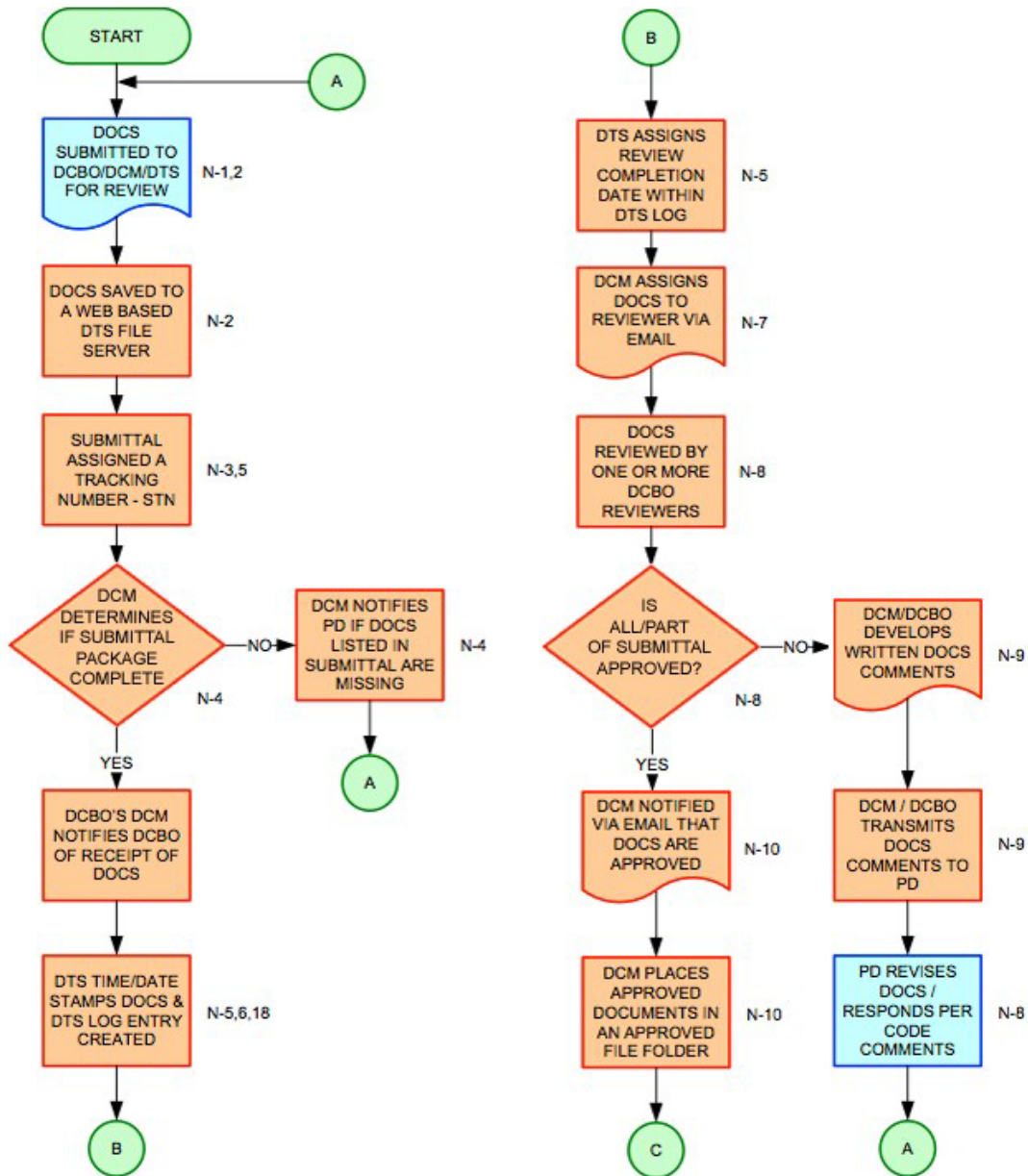

SYMBOLS LEGEND

ABBREVIATIONS USED IN THIS DOCUMENT

ACDP – AS CONSTRUCTED DOCUMENT PACKAGE
 CBC – CALIFORNIA BUILDING CODE
 CEC – CALIFORNIA ENERGY COMMISSION
 COC – CONDITIONS OF CERTIFICATION
 DCBO – DELEGATE CHIEF BUILDING OFFICIAL
 DCM – DOCUMENT CONTROL MANAGER (DCBO)

DOCS – SUBMITTED DOCUMENTS TO DCBO FOR REVIEW
 DTN – DOCUMENT TRACKING NUMBER
 DTS – DOCUMENT TRACKING SYSTEM
 N-“x” - NOTE REFERENCE NUMBER SHOWN ON CHART
 LORS – LAWS, ORDINANCES, REGULATIONS, AND STANDARDS
 PD – PROJECT DEVELOPER / OWNER

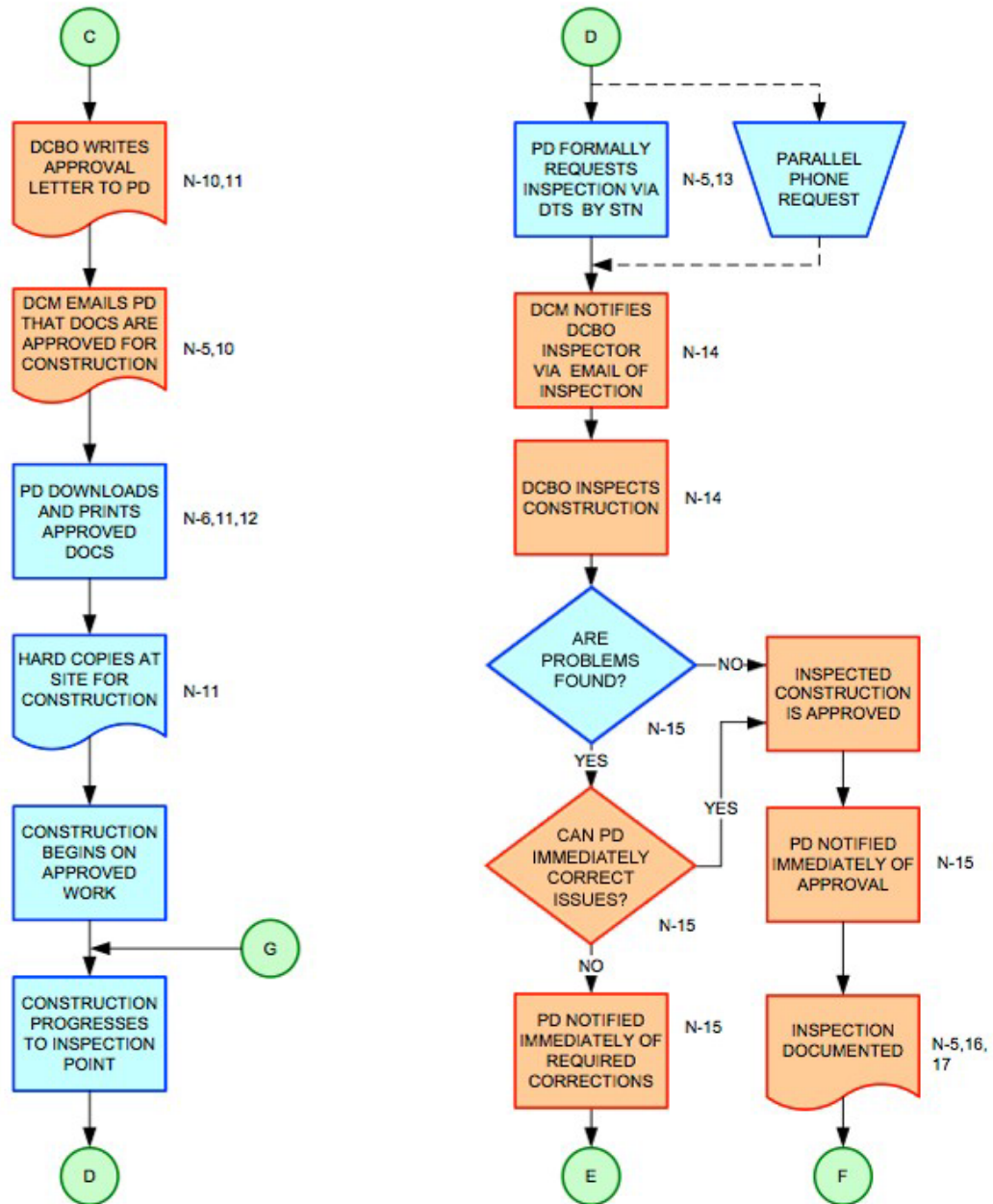

SYMBOLS LEGEND

ABBREVIATIONS USED IN THIS DOCUMENT

ACDP – AS CONSTRUCTED DOCUMENT PACKAGE
 CBC – CALIFORNIA BUILDING CODE
 CEC – CALIFORNIA ENERGY COMMISSION
 COC – CONDITIONS OF CERTIFICATION
 DCBO – DELEGATE CHIEF BUILDING OFFICIAL
 DCM – DOCUMENT CONTROL MANAGER (DCBO)

DOCS – SUBMITTED DOCUMENTS TO DCBO FOR REVIEW
 DTN – DOCUMENT TRACKING NUMBER
 DTS – DOCUMENT TRACKING SYSTEM
 N-"x" - NOTE REFERENCE NUMBER SHOWN ON CHART
 LORS – LAWS, ORDINANCES, REGULATIONS, AND STANDARDS
 PD – PROJECT DEVELOPER / OWNER

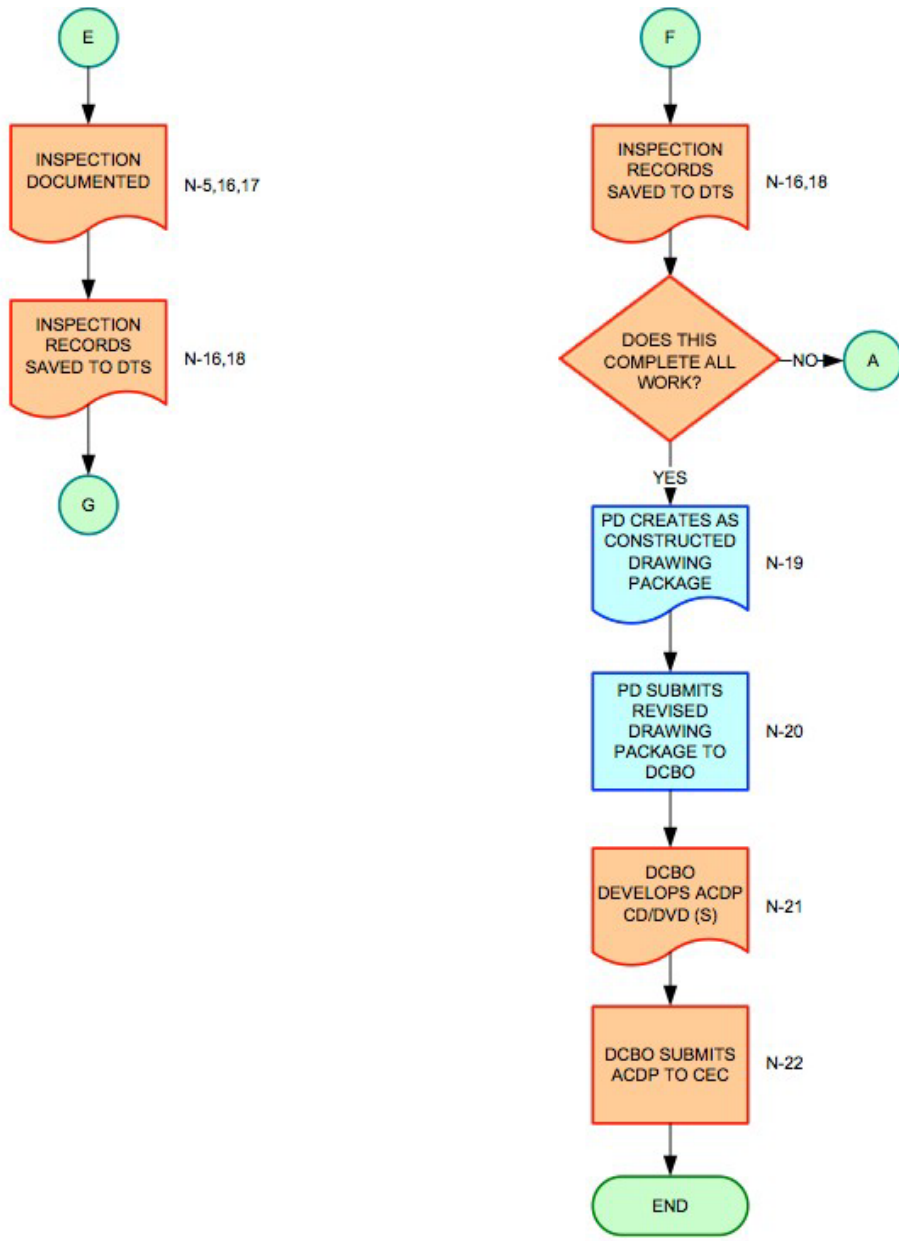

SYMBOLS LEGEND

ABBREVIATIONS USED IN THIS DOCUMENT

- | | |
|---|---|
| ACDP – AS CONSTRUCTED DOCUMENT PACKAGE | DOCS – SUBMITTED DOCUMENTS TO DCBO FOR REVIEW |
| CBC – CALIFORNIA BUILDING CODE | DTN – DOCUMENT TRACKING NUMBER |
| CEC – CALIFORNIA ENERGY COMMISSION | DTS – DOCUMENT TRACKING SYSTEM |
| COC – CONDITIONS OF CERTIFICATION | N-“x” - NOTE REFERENCE NUMBER SHOWN ON CHART |
| DCBO – DELEGATE CHIEF BUILDING OFFICIAL | LORS – LAWS, ORDINANCES, REGULATIONS, AND STANDARDS |
| DCM – DOCUMENT CONTROL MANAGER (DCBO) | PD – PROJECT DEVELOPER / OWNER |

NOTES REFERRED TO IN CHARTS

1. The project developer (PD) shall include a transmittal letter with all submittals that identifies the conditions of certification (COC) that apply to the submittal (i.e. struc, civil, mech, etc.). The transmittal shall include a listing of all attached documents.
2. It is suggested that all submittal documents (DOCS) be uploaded directly to the delegate chief building official's (DCBO) project website. That website shall have the capability to automatically notify the DCBO's document control manager (DCM) of the submittal receipt into the document tracking system (DTS). Alternatively, the docs may be emailed directly to the DCM to be saved to the web-based DTS. Given the size of the typical electronic submittals, it is best that the DTS provide direct upload/download capabilities similar to an ftp internet site. In this flowchart, submittals and docs are somewhat interchangeable terms.
3. Submittals shall be assigned a submittal tracking number (STN) that in some way references the appropriate section of the COC. The submittal shall be assigned a unique sequential identification number (i.e., struct-1-1 for the first document submitted under structural condition 1).
4. The DCM shall review the content of the submittal and verify the presence of all listed docs on the PD's transmittal letter. Any discrepancies shall be communicated to the PD via email so that missing/unreadable documents can be replaced. The DCM will notify the DCBO and other interested parties of receipt of submittal into the DTS.
5. The DTS must include a submittal log feature that records: submittal date; list of included docs; anticipated completion date of the review; current review status; date of approval; revision history; inspection requests; and completed inspections including links to inspection documents. This allows a person reviewing the log to quickly determine what submittals have been made and their status. This log shall be organized by COC requirement. The log shall provide a link (for authorized individuals) to view the submitted docs, comments provided by the DCBO reviewer, and responses made by the PD. These should be "read only" documents and not accessible for editing or re-saving.
6. The DTS shall provide a means to search for/ look up / find documents, drawings, specifications, etc. by the assigned STN. This feature is intended to allow authorized DTS users to quickly find individual docs by STN and to determine their current project status.
7. The DCM assigns (with input from the DCBO) a reviewer (or reviewers) to each submittal and the DCM shall notify, by email, that the docs are available for his review. The email shall include a deadline reminder for the reviewer.
8. All, or portions of, a submittal, may be approved. If a submittal contains multiple drawings or other doc, individual docs within the submittal can be approved separately. This is intended to reduce the paperwork for

submittals. If the individual drawings, or docs are approved separately, the same STN shall be assigned to the subsequent submittal throughout the review process. However, this does not preclude docs from being included within a new submittal receiving a new STN. Subsequent submittals shall simply provide a sequence modifier to designate the revision submitted as appropriate. The intent is to reduce the volume of STN's.

9. The DCBO will provide written review comments to the PD when docs are not approved. These comments will cite the specific CBC laws/ ordinances/ regulations/ standards (LORS), or COC non-compliance observed in the docs. In certain situations, the DCBO may issue conditional approvals of submittals. The DCBO will not provide design suggestions or engineering in non-compliance comments. The responsibility of the DCBO is to review submitted docs for DHD/LORS compliance. If asked but the PD, the DCBO can offer compliance guidance, but should limit that guidance and not offer engineering services.
10. The DCBO will provide a written approval transmittal. The CM will email that transmittal to the PD. This notification will define what documents have been approved, their STN, and will define the inspections required for the work defined on the approved drawings (i.e. soil composition, rebar placement, concrete strength test, etc.).
11. Documents approved by the DCBO must be stamped with the DCBO's approval stamp (secure PDF file format) to become approved construction drawings. These must be present at the construction site and must be used as the construction drawing set for construction to proceed. The DCBO may authorize work to proceed at the PD risk prior to receipt of approved drawings under special approved requests. Work performed inconsistent with the details provided on approved drawings may be subject to demolition. Any rework performed would be the responsibility of the PD. Docs approved for construction must be readily located within the DTS by individuals authorized to access the DTS.
12. It is the responsibility of the PD to download approved docs from the DTS for reproduction from the approved docs folder of the respective STN.
13. The DTS shall provide a means for the PD to formally request inspections directly from within the DTS for completed construction activities (or for progress inspections as applicable). This will serve as the official documentation of requested inspections. The DCBO inspectors are encouraged to interface daily with the PD team members to foster face-to-face verbal communications that parallel the formal computer-based inspection request process. The DCBO is further encouraged to have periodic meetings with the PD team members to discuss planned construction in order to efficiently plan for upcoming inspections.
14. The DTS-based inspection request should automatically initiate an email to the DCBO lead inspector notifying him of the formal inspection request. The email should generate an inspection form that defines the work to be

inspected, related docs, the STN, the inspections required for the defined work, and the date/location of the requested inspection. The DCBO and the PD shall agree upon a suitable typical lead time between the inspection request and the date of the inspections. This lead time should be agreed to before the start of construction but is typically 24 to 48 hours prior to the planned inspection.

15. The DCBO inspectors shall provide immediate (within a few hours of the inspection) written approval/disapproval of any formally inspected work. This can be a hand-written notification using the DTS generated inspection form. If deficiencies are found that cannot be immediately corrected, the inspector shall clearly define how the work failed to comply with the California building code (CBC), laws, ordinances regulations, and standards (LORS), or the approved drawings.
16. The DCBO inspectors shall save these written inspection records to the DTS (saved in the file structure by STN) for permanent record keeping.
17. DCBO's are encouraged to use portable computer devices (laptops, tablet pc's, smart phones, etc.) to access email and the project DTS website to improve the communication, documentation and reporting process described herein.
18. The DCBO DCM shall maintain a log of all email correspondence pertinent to all submittals, reviews, comments, approval, inspection requests and inspection activity.
19. It is the responsibility of the PD to maintain "as-constructed" records for all construction. During construction, these records can be "red-lined" field mark-ups of the approved construction drawings. It is the responsibility of the PD to revise all CAD drawings to an "as-constructed" state upon completion of the construction.
20. The PD shall transmit all "as-constructed" documents to the DCBO upon completion. The DCB)/CEC will not approve the plant for commercial operation until these "as-constructed" docs have been reviewed by the CEC.
21. The DCBO shall assemble all project docs into an "as-constructed" document package (ACDP). The ACDP shall include, but not be limited to, the following typical docs and records: drawings, specifications, calculations, review comments, inspection records, etc.
22. The DCBO is responsible for the compilation of the ACDP onto a CD/DVD electronic media and the submittal of the ACDP to the CEC.

SYMBOLS LEGEND ABBREVIATIONS IN THIS DOCUMENT

ACDP- AS CONSTRUCTION DOCUMENT PACKAGE **CBC-**
CALIFORNIA BUILDING CODE

CEC- CALIFORNIA ENERGY COMMISSION

COC- CONDITIONS OF CERTIFICATION

DCM- DOCUMENT CONTROL MANAGER (DCBO)

DCBO- DELEGATE CHIEF BUILDING OFFICIAL

DOCS- SUBMITTED DOCUMENTS TO DCBO FOR REVIEW

DTN- DOCUMENT TRACKING NUMBER

DTS- DOCUMENT TRACKING SYSTEM

NRNC- NOT REFERENCE NUMBER SHOWN ON CHART

LORS- LAWS, ORDINANCES, REGULATIONS AND STANDARDS

PD- PROJECT DEVELOPER, OWNER

STN- SUBMITTAL TRACKING NUMBER

B. Document Tracking System Submittal Log

The DCBO shall maintain a document submittal log. It shall follow the file structure logic to track submittals from original receipt through final inspection. The submittal log should provide a means to identify:

- Which documents are contained within a submittal;
- Which documents have been approved;
- Which documents have been revised;
- The current document revision number; and
- The status of any inspections performed.

The DCBO shall develop a query function within the document tracking system that facilitates locating and determining the status of every submittal, drawing, inspection, report or other document. The query function shall have the capability to link with the submittal. For example, if an authorized individual knows a particular drawing number,

that drawing number should allow the individual to ascertain the status of that drawing (submittal date, approval status, inspection status, etc.), as well as any supporting calculations. If the authorized individual knows a particular submittal identification number, he should be able to check the status of the submittal and the individual documents contained therein. The query function shall also have the capability to gather data relating to the various sections within the COC. For example, an authorized individual should be able to query a list of STRUC-1 compliance submittals.

C. Access to All Historical Submittal Documents

The document tracking system used by the DCBO must maintain all documents submitted to the DCBO as required by the COCs. It is important that a historical document archive be maintained and accessible to authorized individuals. Simply having the most current version of a document in the document tracking system does not provide an adequate record of the submittal history. As illustrated in Figure 5.1.1 - Document Tracking System File Structure, the document tracking system shall maintain the minimum types of project documents shown. The DCBO must develop a process wherein authorized individuals can search for documents using the logic⁵ depicted in that illustration.

D. Electronic Submittal of Document and Secure PDF's

Documents submitted to the DCBO must be in an Adobe Acrobat® PDF secure electronic file format. The identity of the engineer-of-record is associated with a digital signature. This digital signature is traceable to his or her designated computer. This provides assurances to the DCBO / Energy Commission that all documents submitted to the DCBO were originated by the engineer-of-record, properly reviewed and approved for submittal.

The placement of an electronic professional engineer's stamp on documents is acceptable within the State of California according to California Code of Regulations Title 16, Division 5, § 411 – Board of Rules and Regulations Relating to the Practices of Professional Engineering and Land Surveying. The State of California also permits (in this same section) the use of electronic signatures. The DCBO shall accept the stamping and signing of documents developed by professional engineers using the same secure PDF file format. These stamps and signatures must be traceable to the professional engineer responsible for the development of the given document.

The benefits of this electronic submittal process are twofold. First, mailing of hard copies is not required, which reduces submittal and response times, instead of waiting days for hard copies to arrive, instantaneous documents submittals occur. Second, the promotion of conservation of our natural resources occurs and waste is reduced.

The DCBO must provide document security and backup methods to the CPM for review

⁵ Figure 5.1.1 is located in Section 5.1 of this document. The figure represents the proper organization of project documents within the document tracking system and the logical path one would follow when performing a document search.

and approval to ensure that the electronic submittal process is secure.

E. Partial Submittal Approvals / Re-Submittals

The project owner often submits multiple documents/drawings within a single submittal. The DCBO will review the submittal and approve individual documents within a submittal, if possible, to expedite the document review process. The documents/drawings that require re-work will be allowed to be resubmitted alone as a revision to the original submittal.

F. Document Review Comments and Specific Code Compliance Deficiencies

The DCBO should provide document review comments regarding specific non-code compliance to a project owner. Non-compliance comments should reference the applicable CBSC section or other LORS. Review comments should be limited to non-code compliance issues only. The DCBO should not offer opinions regarding designs.

G. Engineering Changes of Approved Documents – Engineering Change Notices

It is common for projects to reach the construction phase only to discover a design change is required. For relatively minor changes, the change process will involve only simple redline markups of the approved construction drawings by the project owner. For changes that involve more significant design deviations, the engineer of record may perform calculations and develop written directives to the contractor referred to as engineering change notices (ECN). An ECN may provide details on a change in an anchor bolt design, or installation process, or the upsizing of rebar in a foundation to handle an increased load. The DCBO's submittal process should include provisions to accept ECNs for approved drawings when minor redesign is required without the resubmittal of an entire drawing package. ECNs, tracked as a submittal, are linked to the originally approved documents. An ECN requires the engineer of record to submit the engineering change to the DCBO for approval. Once approved, the ECN returns to the project owner's construction team. There, the ECN is attached to the approved construction drawings which are maintained at the construction site. The as-constructed documents should capture the substance of all ECNs.

ECNs do not replace design submittals for new facility components added to a project. ECNs do not replace submittals for major changes in structures, foundations, or footprints of process units.

5.2 Inspection Process

It is the responsibility of the project owner and DCBO to ensure that the construction of a Project is consistent with the approved drawings and specifications. It is the responsibility of the DCBO to perform, or oversee, the performance of the various inspections required by the CBSC. This includes the oversight of the project's special inspector's work. The project owner (not the contractor) employs the special inspectors. The DCBO approves the special inspector work force prior to the commencement of

construction. The special inspectors submit their work reports to the DCBO. The construction inspection documents are the final component associated with design drawing submittals maintained within the DCBO's document tracking system.

The DCBO inspection responsibilities for a Project involve the efforts of both office and field personnel. The two DCBO groups interact daily to ensure the fulfillment of inspection needs in a timely manner and that the documentation is complete. The tasks relating to construction inspection performed by the DCBO include tasks outlined in the following subsections. The key to any successful DCBO field inspection operation is the cultivation of strong team relations with the project owner's construction organization.

A. Approved Document Review Verification

The DCBO field inspection team provides the assurance to the Energy Commission that all construction proceeds in accordance with approved documents. The DCBO's inspectors must observe the DCBO approval stamp on all construction documents used by the construction crews. If that approval stamp is not present, the inspectors should inform the DCBO and the project owner. The DCBO and the project owner may mutually agree that the work may proceed "at risk".⁶

B. Pre-Inspection Oversight and Communications

The DCBO field inspection team should periodically be present during construction to observe work-in-progress. The DCBO is only responsible for compliance of the finished construction with the DCBO-approved construction documents. The purpose of the pre-inspection effort is to communicate to the project owner when observed construction does not comply with the approved construction documents. The work-in-progress observations help prevent re-work of construction. The DCBO field inspection team must establish a relationship with the project owner so that this work-in-progress observation effort is understood to be a value-added effort and not an overreaching additional inspection.

C. Electronic and Verbal Inspection Requests

The primary means for the project owner to request a required inspection of construction is electronic. The use of email, or the established DCBO website, initiates the inspection process. Ideally, this should be a formality. The DCBO's inspection notification process must include the following feedback to the project owner's construction team:

- Acknowledgement that the inspection request was received;
- The inspection is in the process of being scheduled; and

⁶The definition of "at-risk" is construction that proceeds according to non-DCBO-approved plans and specifications. Should a subsequently approved DCBO construction document conflict with an at-risk design, the project owner must take measures to correct the at-risk construction, up to and including demolition.

- Any anticipated delayed scheduling of the inspection.

The DCBO field inspection team must establish a relationship with the project owner's construction team whereby initial verbal notifications of pending inspections prevail. Official notification (by the project owner) should follow all verbal inspection request communication. As construction becomes more complex, the formal notification process provides a documented record of the request to aid inspection planning.

D. Partial Approvals and Progressive Task Inspections

The DCBO construction inspection process must accommodate partial approvals and / or progressive task inspections. Many aspects of Project construction commonly involve multiple-step inspections, such as reinforced concrete (e.g., rebar placement, concrete placement, and strength tests). Other construction may involve long durations between inspection tasks. For example, a building's below-grade drainage system's trench compaction and pipe placement occur well before concrete and structural steel components may be constructed.

E. Electronic Approvals

DCBO inspectors shall provide immediate (within a few hours at most) written approval / disapproval of any formally inspected work. This can be a handwritten notification using the web-based DTS (document tracking system) generated inspection form. Prompt communication of construction deficiencies to the project owner is required. The inspector shall clearly describe how the work failed to comply with the CBSC, LORS, or the approved drawings. The DCBO inspectors shall save written inspection records to the DCBO's web-based document tracking system for permanent record keeping.

The DCBO's document control manager (DCM) shall maintain a log of all email correspondence pertinent to all submittals, reviews, comments, approval, inspection requests, and inspection activity.

F. Status Reporting on Project Website with Photos

The DCBO field inspection personnel play a key role in project status reporting. Their presence at the construction site enables the most up-to-date progress reporting available. Simple summary progress status reporting is adequate, unless specific issues arise that warrant more detailed reporting (e.g., commencement of major unit of construction, completed plant components, arrival on site of major PFAs, resolution of major issues, significant weather factors/impacts, unexpected events, accidents, etc.).

Adequate weekly progress reporting includes current progress photo-documentation. Photo-documentation standards include: a brief description; directional reference and site map location, automatic date/time stamp, and graphic scales (when applicable). DCBO progress reporting on the project website provides easy access to interested parties.

5.3 Site Presence

The presence of the DCBO at the project site is essential for the successful completion of

any Project. That ongoing presence fosters good communications and relationships, allows quick response to the needs of the project owner, and reinforces the role that DCBO inspection plays in a process plant environment where third party/jurisdictional agency inspections are not always common. Several key factors reinforce the role of DCBO project inspection.

A. On-Site Office - Separate and Private Facilities

The DCBO project inspection staff should maintain an on-site office once construction begins. Their office must be separate and private from the site offices maintained by the project construction staff. This allows the DCBO to conduct business in a confidential setting. One benefit is to provide an anchor for the construction inspection operations. Construction personnel know that this single location is available to interact/communicate with DCBO inspection personnel. The “permanent” presence provides the message that the DCBO inspectors are part of the everyday plant construction activities.

B. Best Available Communications

The DCBO office should be equipped with the best available communication for voice and internet access. Voice communications should include cellular telephones and landlines, if commercially available at the site. The DCBO should provide telephone message recording for field inspection operations when no dedicated office personnel are present. Some solar electric generating stations are in remote sites where landline voice lines are not available.

C. Regular Communication with Project Owner

It will benefit the DCBO field inspection staff to be proactive in their communication with the project development staff. Daily communications are to be the minimum frequency acceptable to the Energy Commission. Daily communications establish a rhythm for the project where inspection expectations are firmly established.

D. Regular Status Meetings with Project Owner

Large industrial construction projects involve regular key team member meetings. The size of the project teams is often so large that regular coordination between construction functions is necessary for success (e.g., earthwork, site drainage, foundations, structural steel, electrical, mechanical, environmental, and other disciplines). This inter-discipline construction coordination fosters efficient work process transitions and scheduling. DCBO field inspection personnel should be part of these coordination meetings from day one. It is imperative that the DCBO field inspection personnel be part of some of these periodic open discussions. This is an opportunity for the DCBO personnel to develop effective relationships with the project owner’s project team members.

E. Coordination and Planning of Upcoming Inspections

The DCBO should provide only field inspection staff needed for a project. The DCBO should strive to have all field inspectors properly utilized for the inspection workload. The

periodic project owner's project team meetings are a perfect venue to coordinate and plan for upcoming inspections. Mutually established short and long-range inspection needs are best. It is the Energy Commission's intent for the DCBO to efficiently staff the inspection team.

F. Visible Site Presence

The DCBO inspection personnel should maintain a visible presence at the project construction site. Simply spending time observing the construction achieves this visible presence. This presence accomplishes several important construction mindsets. The first is that the construction will proceed with Energy Commission constant oversight and that the Energy Commission will be vigilant in the enforcement of the COCs. Second, is that the construction team relationships can be established. Third, the project owner's construction team can potentially realize the value-added resource the inspectors provide with code compliance issues.

6.0 Specific Facility Guidance Issues

The design and construction of natural gas-fired and solar generating stations has experienced design conditions that are not specifically addressed within the CBSC. This has at times, led to the DCBO trying to "fit" the design compliance into a section of the CBSC. It is the intent and goal of the Energy Commission to avoid these issues and to work through any unusual design issues in a fair and cooperative manner. It is not the Energy Commission's desire for the DCBO to hire research-engineering staff to develop complex solutions – that is the responsibility of the project owner. If the project owner can offer a reasonable industrial code standard for the particular design feature, the DCBO may accept that standard and not judge design compliance only using the CBSC, which may not address complex non-building design issues.

6.1 Common Issues Observed

The most common types of issues observed with past projects have involved:

- Pre-fabricated assembly construction and review;
- Fire prevention issues which did not consider NFPA 850 – Recommended Practice for Fire Protection for Electric Generating Plants and High Voltage Direct Current Converter Stations;
- The impact of the Federal Natural Gas Pipeline Regulations 49 CFR Part 192 - Transportation of Natural and Other Gas by Pipeline: Minimum Federal Safety Standards on fuel gas pipeline and compressor station design;
- Requirements for fire protection during the construction phase of a project vs. the completed Project; and
- Familiarity issues with the interaction of the Industrial Piping codes vs. CBSC plumbing and mechanical codes;
- Specification compliance and inspections of all linear facilities (gas,

transmission, roadway and water), and Energy Commission jurisdictional appurtenant facilities and utility tie-ins as per Public Resources Code §25120 and Cal. Code Regs., tit. 20 §1702, subd. (n);

- DCBO oversight for repairs and replacements during construction and until the final building occupancy permit is issued.

Past DCBO written guidance addresses many of these issues. (See Section 6.4 below) The Energy Commission recommends the DCBO review these guidance documents with the project owner where applicable.

6.2 Avoid Creating Issues

The DCBO should avoid creating real or perceived design issues whenever possible. The best conflict avoidance tactic is the offering of code specific references to back the DCBO position on a matter. It is also best to listen to the project owner's argument for their position as well. The DCBO should avoid "my opinion" statements or "my experience" statements and maintain written code-based positions on issues.

6.3 Excessive Design Reviews – Seek Energy Commission Input

The DCBO should avoid excessive design reviews. This does not imply that the problem resides with the DCBO. Some designers may not be familiar with particular design issues (e.g., California Seismic Code compliance). If it appears the project owner's engineer is having difficulties with a design code compliance, addressing the issues early is best:

- Offer a round table discussion of the issue with all parties, and
- Seek the Energy Commission's input to help resolve the problem via a third-party perspective, if the round table discussion does not resolve the problem.

6.4 Specific Energy Commission Addressed Issues

Many past issues have been resolved that address common design features found at most, if not all, Project facilities. A number of these resolution efforts have involved the assistance of Energy Commission support personnel. Exhibit 2 – Specific Project Directives includes a collection of the common design guidance documents developed to date.

Exhibit 1 – Abbreviations, Terms, and Definitions

Abbreviations and Terms

American National Standards Institute (ANSI)
American Petroleum Institute (API)
American Society for Testing and Materials (ASTM)
American Society of Civil Engineers (ASCE)
American Society of Mechanical Engineers
(ASME) Americans with Disabilities Act (ADA)
Application for Certification (AFC)
California Building Standards Codes (CBSC)
California Electric Code (CELC)
California Energy Commission (Energy Commission)
California Fire Code (CFC)
California Mechanical Code (CMC)
California Occupational Health, and Safety Administration (Cal/OSHA)
California Plumbing Code (CPC)
California Public Utilities Commission (CPUC)
California State Fire Marshal (CSFM) Compliance Project Manager (CPM)
Conditions of Certification (COCs)
Delegate Chief Building Official (DCBO)
Document Control Manager (DCM)
Document Tracking System (DTS)
Emergency Shut Down System (ESD)
Engineering Change Notice (ECN)
Environmental Protection Agency (EPA)
Federal Energy Regulatory Commission (FERC)
Hazardous Liquid Pipeline Safety Act of 1979 (HLPSA)
Hazardous Materials Management Plan (HMMP)
Heat Recovery Steam Generator (HRSG)
International Electrotechnical Commission (IEC)
Institute of Electrical and Electronics Engineers (IEEE)
Laws, Ordinances, Regulations, and Standards (LORS)
Liquefied Natural Gas (LNG)
Lower Explosive Limit (LEL)
National Fire Protection Association (NFPA)
Natural Gas Pipeline Safety Act of 1968 (NGPSA)
Non-compliance reports (NCR)
Normal Temperature and Pressure (NTP)
Occupational Safety Health Administration (OSHA)
Office of Pipeline Safety (OPS)
Petition to Amend (PTA)
Pipeline and Hazardous Materials Safety Administration (PHMSA)
Piping and Instrumentation Diagrams (P&ID's)
Pounds per Square Inch Gauge (PSIG)
Pre-Fabricated Assemblies (PFA)

Quality Assurance / Quality Control (QA/QC)
Siting, Transmission and Environmental Protection Division (STEP)
Storm Water Pollution Prevention Plan (SWPPP)
Submittal Tracking Number (STN)
Underwriters Laboratories (UL)
Uninterruptible Power Supply (UPS)
United States Code (USC)
United States Department of Transportation (USDOT)

Exhibit 2 – Specific Project Directives

E2.1 Pre-Fabricated Assemblies (PFAs)

Pre-Fabricated Assemblies (PFAs) are unitized components of a Project that have been fabricated/assembled in their entirety, offsite, at a supplier's facility. Many individual components (structural, mechanical, and electrical) comprise these unitized assemblies, shipped to the power plant site as a unit, generally supported by a structural steel skid, or frame. Transportation is typically by truck or rail and lifted by a crane. Project PFAs typically include: power distribution control modules, combustion turbine enclosures, natural gas compressors, water treatment skids, circulating water pump skids, laboratories, etc.

For the purpose of DCBO plan check and review, PFAs fall into three different categories.

- **Buildings** - A PFA should be considered a building structure when personnel are likely to spend normal workdays performing various duties within the enclosure. In these cases, the PFA should be considered an occupied structure.
- **Equipment Enclosures** - An equipment enclosure is an un-occupied structure surrounding a piece of mechanical equipment for the purpose of weather protection or sound suppression. This would be a structure where personnel are not expected to perform daily operating or maintenance duties. This type of PFA should not be considered an occupied structure.
- **Non-Enclosed Equipment Skid** - An equipment skid is a PHA with an open structural frame that supports an assembly of mechanical devices such as a pumping unit and piping. This type of PFA should not be considered an occupied structure.

All PFAs are by the nature typically of robust construction to facilitate transportation to the job site. PFAs should not require an exhaustive structural plan check and review by the DCBO. The anchorages and foundations should be reviewed for seismic compliance with the CBSC. A DCBO visual inspection should be performed to examine the PFA for damage during shipment and handling. During this inspection, the DCBO should verify the building basic construction/layout with supplied plans.

For PFAs that house large electrical components and systems (power distribution,

uninterruptible power systems, motor control centers, etc.) the normal electrical inspections should be performed unless the entire enclosure is affixed with the appropriate UL Listed sticker, certifying that the PFA has been assembled and inspected as a unit per approved nationally recognized standards and guidelines.

For PFAs that support process piping systems, the normal audit verification process for piping materials, inspections, and tests of the process piping system should be conducted by the DCBO.

For PFAs that are considered Buildings as defined above, the DCBO should perform the normal architectural review regarding ingress/egress, fire life safety compliance, as well as other reviews typically performed for offices, warehouses, shops, garages, and other occupied structures.

The project owner should provide the DCBO with the appropriate design drawings and QA/QC documentation that accompanies a PFA. This documentation will be used for field inspections to verify that the delivered PFA matches the provided drawings and manufacturer's QA/QC inspection documents. In most cases, this documentation should include (but not limited to) the following:

- Structural design drawings;
- Equipment (mechanical and electrical) layout plan and detail drawings;
- Unit performance specification (design basis) and intended use applications/limitation documentation;
- Mechanical component's manufacturer's data sheets;
- Electrical component's manufacturer's data sheets;
- Structural welding inspection non-destructive testing records;
- Hydrostatic testing records (for ASME piping components); and
- Electrical equipment testing records (breaker trips, wiring short circuit and insulation testing).

CBSC §1704.2.5.1, does not require special inspections of prefabricated elements when the work is done on the premises of a registered and approved fabricator. Such "approval" must be based upon review of the fabricator's written procedural and quality control manuals and periodic auditing of fabrication practices by an approved special inspection agency. Upon fabrication completion, the approved fabricator must submit a certificate of compliance to the DCBO stating that the work was performed in accordance with the approved construction document.

If a DCBO has concerns regarding a specialized piece of equipment, those concerns should be directed to the Energy Commission's CPM for guidance.

E2.2 Use of Industry Code Recommended Practices

The requirements of all applicable LORS will be enforced by the DCBO accordingly. Industry publications written as a recommended practice place the responsibility on the

project owner to evaluate and incorporate the recommended practices, he determines appropriate for the plant. Typically, it is not within the authority of the DCBO to enforce recommended practices, with one exception. NFPA 850 - Recommended Practice for Electrical Generating Plants and High Voltage Direct Current Converter Stations is the fire protection guideline for Project and is considered a standard regardless of its title. The CBSC and CFC do not specifically provide guidelines for Projects and other similar facilities. To address the lack of topic specific guidelines, the CFC does consider “.... compliance with applicable standards of the NFPA or other nationally recognized fire safety standards, as approved, shall be deemed as prima facie evidence of compliance with the intent of this code.” per Part 1, Section 102.8 Subjects not regulated by this code.

In cases of system safety, the DCBO may require the project owner to provide written justification as to the rationale behind their decision not to follow the guidelines of a recommended practice.

E2.3 Ammonia Storage Tank Requirements – Anhydrous and Aqueous

Ammonia is often present as a process chemical at a power plant to reduce air emissions. Ammonia can be present in either of two forms: anhydrous (NH₃) or aqueous (NH₄OH: aka - aqua ammonia or ammonium hydroxide – ammonia concentrations 10%-35%). However, aqueous ammonia is the common form of ammonia used in the combined-cycle process.

These two forms of ammonia have different storage container requirements as mandated by state and federal regulations. Anhydrous ammonia must be stored in a ASME Code pressure vessel with an allowable working pressure of at least 265 psig. This is a requirement of California Code of Regulations, Title 8, Section 458, Design and Construction of NH₃ Tanks and U.S. Department of Labor, Occupational Safety & Health Administration, 29 CFR, Part 1910.111, Section 1910.111(c), Storage and Handling of Anhydrous Ammonia – Non-Refrigerated Storage Containers (has a minimum working pressure requirement of 250 psig).

Aqueous ammonia is normally stored in a steel tank with a design pressure of 25 psig. This design pressure exceeds the allowable design pressure limits for low-pressure tanks as defined by API 620 Design and Construction of Large, Welded, Low-Pressure Storage Tanks. Therefore, these low-pressure aqueous ammonia storage tanks must be designed to meet the requirements of the ASME Boiler and Pressure Vessel Code, Section VIII, Unfired Pressure Vessels.

However, the requirements of ANSI K61.1, Safety Requirements for the Storage & Handling of Anhydrous Ammonia, are only applicable for anhydrous ammonia tanks with design pressures of 250 psig or greater.

E2.4 Labeling and Listing – Material Approvals vs. Inspection for Compliance

The project owner shall use only materials that are manufactured per recognized quality standards.⁷ Through the Energy Commission’s third-party beneficiary language the DCBO is granted the authority to enforce the CBSC including the project owner’s QA/QC process of material compliance. The DCBO shall not impose an administrative process that requires the project owner to submit all material for approval prior to construction.

The DCBO shall use field inspections as the primary means to ensure that materials meet minimum quality standards required by the LORS. The DCBO should not implement an administrative process that requires the project owner to submit individual material data sheets for DCBO review and approval. This is an excessive administrative requirement not approved by the CBSC.

Should the DCBO field inspections identify substantial amounts of non-conforming materials, inspections that are more stringent may be justified.

The Project environment involves the use of certain equipment that is not supplied with labeling and listing as defined by the CBSC. For example, the combustion turbine generator and steam turbine generator are specialized machines that do not typically comply with the labeling and listing requirements defined by the CBSC. These are special machines manufactured by companies knowledgeable and experienced with their installation and operation. The DCBO should normally accept these machines on their own merit, without requiring the project owner to obtain special listings for these machines.

If a DCBO has concerns regarding a specialized piece of equipment, those concerns shall be communicated to the Energy Commission’s CPM for direction.

E2.5 Natural Gas Pipeline Regulations and Compressor Building Design

If a Project involves the design and construction of a natural gas pipeline, it will be required to comply with the Federal Regulations 49 CFR Part 192. The United States Department of Transportation (USDOT) provides oversight for the country’s natural gas pipeline transportation. Their responsibilities are promulgated under Title 49, United States Code (USC) Chapter 601. The Pipeline and Hazardous Materials Safety Administration (PHMSA), Office of Pipeline Safety (OPS), administers the national regulatory program to ensure the safe transportation of gas and other hazardous materials by pipeline.

Two statutes provide the framework for the PHMSA. The Natural Gas Pipeline Safety Act of 1968 (NGPSA), as amended, authorizes the USDOT to regulate pipeline transportation

⁷ Materials are considered to comply with this requirement if they are labeled / listed by a nationally recognized material testing laboratory or national standard.

of natural (flammable, toxic, or corrosive) gas and other gases as well as the transportation and storage of liquefied natural gas (LNG). Similarly, the Hazardous Liquid Pipeline Safety Act of 1979 (HLPESA), as amended, authorizes the USDOT to regulate pipeline transportation of hazardous liquids (crude oil, petroleum products, anhydrous ammonia, and carbon dioxide). Both of these pieces of legislation were re-codified as 49 USC Chapter 601.

The OPS shares portions of this responsibility with state agency partners and others at the federal, state, and local level. The State of California is certified under 49 USC Subtitle VIII, Chapter 601, §60105. The state has the authority to regulate intrastate natural and other gas pipeline facilities. The California Public Utilities Commission (CPUC) is the agency authorized to oversee intrastate gas pipeline facilities, similar to those proposed by the applicant. (The California State Fire Marshal (CSFM) has jurisdiction for hazardous liquid pipelines.)

The federal pipeline regulations published in Title 49 of the Code of Federal Regulations (CFR), Parts 190 through 199. 49 CFR 192 specifically address natural and other gas pipelines. The CPUC also requires some additional design and operations requirements in California. Many of these pipeline regulations are performance standards. These regulations set the level of safety allowing the pipeline operator to use various technologies to achieve the desired result.

Should the pipeline be designed and constructed in such a way that the Project's natural gas compressors are located outside the main Project property boundaries, the compressor station may also be jurisdictional to 49 CFR Part 192.

49 CFR Part 192 dictates certain safety features that must be provided regardless of building code requirements. These safety features include the following items. Where these requirements are vague, additional Energy Commission clarification has been provided. It should be noted that for compliance with 49 CFR Part 192, the USDOT is the jurisdictional agency and not the Energy Commission. However, the Energy Commission has determined that these minimum requirements, as clarified herein, may be applied to any natural gas compressor buildings associated with a Project under their jurisdiction, at the discretion of the Energy Commission, regardless of any USDOT jurisdiction.

1. The compressor building must be in a location that minimizes the impact of fire on structures on adjacent property not under the control of the operator - 49 CFR Part 192.163(a).

The building must be constructed according to CBSC Title 24, Part 9, Chapter 5 – Fire Service Features, Section 503 - Fire Apparatus Access Roads for requirements of fire apparatus access roads (setback guidelines), for the appropriate occupancy classification.

2. Space around the compressor building must be adequate to allow the free movement of firefighting equipment - 49 CFR Part 192.163(a).

The building must be constructed according to the setback guidelines established in the CBSC and CFC for the appropriate occupancy classification and CBSC Title 24, Part 9, Chapter 5 – Fire Service Features, Section 503 - Fire Apparatus Access Roads. Local ordinances regarding fire equipment turning radii, dead end/turn around requirements will also apply to the spacing requirements reviewed by the DCBO.

3. Compressor buildings shall be constructed of noncombustible materials (where piping is greater than 2 inches in nominal diameter) - 49 CFR Part 192.163(b).

The building structure should be constructed according to the requirements of the CBSC for the building occupancy type (either F-1 or H-2) and acceptable noncombustible materials (building construction Types I or II) as defined by CBSC Title 24, Part 2, Chapters 6 – Types of Constructions, Section 602.2 and Chapter 7 – Fire and Smoke Protection Features, Section 703.5.

4. Any main compressor building must have at least two unobstructed exits (per floor) with panic hardware on the doors that open outwardly - 49 CFR Part 192.163(c).

The building should have exits provided based on occupant load or use, per CBSC Title 24, Part 2, Chapter 10 – Means of Egress, Section 1006. The intent is that a person must be able to escape immediately from the building by proceeding in a direct path to a door that will swing open in the direction of egress (outward). These doorways should not have any objects, stationary, or moveable, placed in front of the doorway that would slow a person's egress from the building. These doors should be located in the building so as to provide alternative escape routes should one direction not be possible due to fire or other reason. The hardware on the door should be of the "panic bar" type, opened without a key, from the inside of the building without having to significantly slow the person's speed of egress.

5. All escape routes from the buildings must be unobstructed - 49 CFR Part 192.163(c).

The escape routes from the buildings should be designed and reviewed according to the requirements of CBSC Title 24, Part 2, Chapter 10 - Means of Egress.

6. All fenced areas around compressor buildings must have two exits providing escape to a place of safety - 49 CFR Part 192.163(d).

Similarly, to numbers 4 and 5 above, a person's speed of egress should not

be significantly slowed by the path of egress, or the type of gate hardware installed at the site. No stationary or moveable objects should be installed/stored/placed in this pathway.

7. All fenced areas less than 200 feet from the compressor building must have gates that open outwardly, and when occupied, must be capable of being opened without a key - 49 CFR Part 192.163(d).

Similar to 4 and 5 above, the fence gate should remain unlocked while occupied (egress does not require a key) with latching hardware that does not significantly slow the egress of persons leaving the area.

8. All electrical equipment and wiring must conform to NFPA 70 - 49 CFR Part 192.163(e).

This requirement needs no further explanation.

9. The station must be equipped with an emergency shut down system (ESD) that: isolates the station piping from the incoming and outgoing pipeline, shuts down any gas-fired equipment, blows down the station piping to a safe location, and is operated from at least two sites outside the gas area of the station near emergency egress gates and not more than 500 feet from the limits of the compressor station. This ESD must not shut down emergency operating power for safety systems and emergency egress lighting - 49 CFR Part 192.167(a).

The compressor station must be equipped with manual push button stations (e.g., 2 minimum red mushroom head - maintain position push buttons that must be reset at the site) that initiate an emergency shut-down of the station's compressor(s). This emergency shut-down should be wired directly into the compressor motor control/prime mover control circuits and should not rely on any outside control system to "pass" the compressor shut-down control signal. For example, for an electrical motor driven compressor, the ESD should be wired directly into the motor control center in such a way that the power to the motor starter coil is interrupted. The location of the ESD must not be situated in such a way as to allow the operation of the device by unauthorized individuals.

This ESD should also initiate the actuation of compressor station power-operated valves that will automatically close a single station inlet valve and a single station outlet valve. This action will isolate the compressor station piping from any outside supply of natural gas. The ESD should also actuate a power-operated valve that vents (blows down) all the compressor station piping to atmosphere at a location that is free from accidental ignition sources. This action will reduce the amount of gas available for a release

inside the building.

The term “power actuated valves” includes a family of actuators that can be powered by electrical, pneumatic, or hydraulic power sources. The actuation of these power- operated valves should be “fail safe”. The term “fail safe” is herein referred to as the ability to close upon receipt of an ESD signal regardless of any loss of primary actuation power.

The ESD must not de-energize any electrical circuits used for any station lighting for emergency egress assistance, equipment protective devices, or the station control systems. For compressor stations monitored and controlled from a remote-control room, the remote-control system should also possess the capabilities to “simulate” a local ESD.

The compressor station should be equipped with an Uninterruptible Power Supply (UPS) that is capable of operating critical operating and safety devices during power failures (emergency electrical power). This UPS should be cable of powering egress lighting for a period of time not less than that required by the CBC Chapter 10 Means of Egress. The duration of operation of operationally critical devices supplied by this UPS should be at the discretion of the owner but should be of sufficient duration to operate the station isolation valves and blow down valves to a “safe” position.

The DCBO is to review the P&ID for the compressor station as well as the control wiring to determine that all safety features have been incorporated into the design of the station electrical and mechanical controls.

10. The station piping must be protected by a pressure relief system or other suitable protective devices of sufficient capacity and sensitivity to ensure that the maximum operating pressure is not exceeded by more than 10%. Each vent line that exhausts gas from a pressure relief valve of a compressor station must extend to a location where the gas may be discharged without hazard - 49 CFR Part 192.169(a) and (b).

The compressor station piping must be designed so that pressures cannot exceed 110% of maximum operating pressure per applicable industry codes. This pressure- control design should consider high pressure conditions that may occur during normal flowing conditions and during idle times. This may require the use of large pressure relief valves sized to accommodate the full flow of the station (in the event of an inadvertent closure of a downstream block valve) as well as smaller valves that relieve pressure trapped between closed valves (thermal relief valves) in the station piping.

The DCBO shall review the Piping and Instrumentation Diagrams (P&ID's) for the compressor station to determine that adequate over-pressure protection has been provided in the station piping and control designs.

11. Each compressor station must have adequate fire protection facilities. If fire pumps are part of these facilities, their operation must not be affected by the emergency shut-down system - 49 CFR Part 192.171(a).

The compressor station must be designed and built with fire suppression equipment that could reasonably be expected to extinguish a natural gas fire within the building due to equipment failure or other accidental release. The sizing of fire suppression systems should follow the guidelines of CBSC Title 24, Part 2, Title 24, Part 9 California Fire Code, NFPA 13 Automatic Sprinkler Systems Handbook, NFPA 58 Liquefied Petroleum Gas Code, and NFPA 59 Utility LP – Gas Plant Code (NFPA 58 and 59 required by 49 CFR Part 192.11).

12. Each compressor station prime mover other than an electric motor, must have automatic shut-downs to protect against exceeding the maximum safe speed of the prime mover or compressor - 49 CFR Part 192.171(b).

This is an equipment protective safety system that is normally included in the “compressor control system package”. This is not a building code issue. Its inclusion in the motor controls should be verified by the DCBO via review of the P&ID’s. An engineering review of this control feature is the responsibility of the owner/engineer, not the DCBO.

13. Each compressor unit within a compressor station must have a shut-down, or alarm device, that operates in the event of inadequate cooling or lubrication of the unit - 49 CFR Part 192.171(c).

This is an equipment protective safety system that is usually included in the compressor control system package. This is not a building code issue but, it’s inclusion in the motor controls should be verified by the DCBO via review of the P&ID’s. An engineering review of this control feature is the responsibility of the owner/engineer, not the DCBO.

14. Each natural gas-powered prime mover (engine) that operates with pressure injection must be equipped so that stoppage of the engine automatically shuts off the fuel and vents the engine distribution manifold. The muffler of a gas engine must have vent slots, or holes, in the baffles of each compartment to prevent gas from being trapped in the muffler - 49 CFR Part 192.171(d) and (e).

This is an equipment protective safety system that is usually included in the “compressor control system package”. This is not a building code issue but it’s inclusion in the motor controls should be verified by the DCBO via review of the P&ID’s. An engineering review of this control feature is the responsibility of the owner/engineer, not the DCBO.

The venting of the engine fuel manifold should be piped to the station blow down piping and should be connected to that piping downstream of the

ESD-actuated emergency blow down valve specified in Item 9 above.

15. Each compressor station building must be ventilated to ensure that employees are not endangered by the accumulation of gas in rooms, sumps, attics, pits, or other enclosed places - 49 CFR Part 192.173.

Natural gas has very little health hazard potential to humans. It is not an irritant, does not absorb through the skin, and is not a carcinogen. The primary risk to humans is at high concentrations where it may cause dizziness, headache, lack of muscular coordination, diminished mental alertness, cyanosis, narcosis, dyspnea, or death by asphyxiation. At lower concentrations, the risk to humans is from fire/explosion. The buildings, regardless of occupancy class determined by the DCBO, should be equipped with mechanical ventilation that minimizes the risk of gas accumulations. The ventilation system should be designed to maintain gas concentrations below 20% Lower Explosive Limit (LEL).

The ventilation should be activated while persons are occupying the building for maintenance purposes by integration with inside lighting switches (or other equivalent means). The ventilation should be sized to produce six air changes per hour in the building. It should also be activated when any gas is detected over concentrations of 20% LE, whether or not the lights are in the "on" position. The ventilation should be installed to exhaust from a point high in the building since natural gas is lighter than air and will float to the roof. The inlet vent (louvered panel) should be situated on the opposite side of the building to create a cross flow of air inside the building. If practical, the air flow path should be parallel to the axis of the compressor units to reduce obstructions in the airflow path. In order to control this system, continuous air monitoring within the building is required.

Compressor buildings are considered equipment weather/sound enclosures. These should not be used as occupied spaces for normal operations and/or workspaces.

The DCBO should evaluate the proposed ventilation system according to a Group H Occupancy (CBSC Section 307) as a Product-Conveying Ventilation System as defined by California Mechanical Code Chapter 5 "Exhaust Systems", Section 505.0. All electrical components within this exhaust system should be non-sparking and listed for Class I, Division 2 service.

16. Natural gas compressor station buildings must be equipped with fixed gas detection and alarm systems – 49 CFR Part 192.736.

The natural gas compressor building should be equipped with gas detection devices that can detect concentrations of gas at, or below, 20% LEL. These detection devices should be situated in sufficient numbers (at least one per compressor unit) to detect a release from the compressor itself or from a flanged connection as quickly as possible. The building should also have an

additional gas detector near the roof peak. These devices should be analog devices that give continuous gas readings (via facility monitoring and control system) back to the facility control room. Any device that detects gas above 10% LEL, should activate the ventilation system as described in 49 CFR Part 192 Safety Equipment Requirement 15 above, whether or not the building is occupied.

The detection of any gas concentrations above 10% LEL should initiate an alarm within the facility central control room. Visual alarm signal lights should be provided outside and inside the building that flash when concentrations of gas exceed 25% LEL. Signs should be provided adjacent to these alarm lights that say "Gas Detection Alarm" in white letters on a red background.

This alarm should also activate the compressor station ESD after a period of time and before the concentration of gas exceeds 50% LEL.

The DCBO should review the P&IDs to ensure that these devices have been included in the station design and integrated into the control system.

E2.6 Construction Oversight – Means and Methods vs. Code Compliance

It is the responsibility of the project owner to construct the Project according to the COC's, the DCBO-approved plans and specifications, and all LORS. The project owner selects the means and methods utilized, provided they do not hamper the DCBO's progress inspection of the work (e.g., free access to the work in progress), nor jeopardize worker/inspector safety.

It is not within the authority of the DCBO to dictate the construction means and methods. It is within the DCBO's authority to ensure the work performed is in accordance with approved drawings and specifications. The DCBO should focus on the end product of the work and not dictate how this is accomplished.

Should the DCBO observe conditions that in his opinion may affect the final work product, he may request additional inspections prior to commencement of subsequent stages of work. For example, if a foundation's sub-grade compaction appears to be compromised by rain, vehicular traffic, or other disturbances, the DCBO is within his authority to request special inspection of that sub-grade prior to any concrete pours. There would be no other way to verify the quality of work otherwise.

There are certain construction techniques that may require DCBO review. For example, overhead formwork for reinforced concrete pours, false work, and engineered shoring for excavations greater than 20 feet deep require design by a licensed civil or structural engineer. These should be submitted to the DCBO for review and approval prior to construction.

If a DCBO has concerns regarding an ongoing construction practice, those concerns

should be referred to the Energy Commission's CPM for direction.

E2.7 Professional Engineer (PE) Stamp Requirements for Out of State PFAs and Process Equipment

In almost all situations, any "engineered" components used within an Energy Commission jurisdictional Project must be accompanied by design drawings prepared by an engineer, duly licensed to practice civil, mechanical, or electrical engineering within the State of California. There may be limited situations when PFAs, or other minor components used within an Energy Commission jurisdictional plant, can be accepted with a non-California licensed professional engineer stamped set of design drawings and supporting calculations. It should be noted that the Energy Commission does not restrict the project owner from utilizing PFAs that are designed and constructed outside the State of California. It should also be noted that the use of any PFAs does not exempt the project owner from compliance with all LORS.

Only non-enclosed equipment skid PFAs, which comply with all of the following requirements, may be utilized without California PE stamped drawings and supporting calculations:

- The PFA is a process system component and not a building;
- The PFA does not include a shade cover, awning, or other structure over the equipment;
- The PFA does not include a stationary, track mounted, or otherwise supported crane or hoist;
- The PFA does not include personnel access platforms greater than 5 feet above the PFA's installed surrounding finished access level or adjacent grade;
- The PFA does not include chemical storage facilities;
- The PFA does not include fixed fire protection equipment; and
- The PFA does not include fixed area lighting equipment.

However, all PFAs, including those that are not required to be accompanied by California PE stamped drawings and supporting calculations, should have documentation supporting their design basis and QA/QC procedures and inspections. When a PFA is a non-enclosed equipment skid, it may be classified in one of two ways. First, the PFA may be a standard assembly of components the supplier fabricates into a single unit for sale/use anywhere in the United States or abroad. Second, the PFA may be a custom-manufactured assembly of components that is unique to the Project to which it is being incorporated. The DCBO may accept the stamp of an out-of-state engineer or an appropriate label or listing as a QA/QC assurance the PFA was designed and constructed to acceptable standards. Regardless of the type of PFA, the PFAs QA/QC documents

should be reviewed as a part of the overall process system QA/QC audit.

If a DCBO has concerns regarding a specialized piece of equipment, those concerns should be referred to the Energy Commission's CPM for direction.

E2.8 Generating Plant Start-Up Responsibilities of DCBO's

The DCBO has the authority to enforce the CBSC and to perform plan reviews and construction inspections according to the authority delegated by the Energy Commission. It is not the Energy Commission's intent for the DCBO to oversee and approve the mechanical start-up operation of the power plant. Once the physical plant facilities have been constructed and deemed materially complete, the DCBO has no further authority to ensure that the plant operates to any performance standards unless specifically identified as a compliance task within the COC.

E2.9 Practical vs. Hard-Line Approach to Code Interpretation

It is the goal of the Energy Commission that all Projects designed and constructed under its jurisdiction are completed in a manner that complies with all LORS. The DCBO should be diligent during the design-review and construction-inspection process to ensure that this goal is achieved. However, it is not the desire of the Energy Commission to provide unreasonable interpretations of the text of the LORS, nor to interfere with any design and construction detail options available to the project owner, when those options are not a LORS requirement. However, the DCBO does have the authority to review these options to ensure that they do not inadvertently pose a risk to personnel, property, or the public.

Construction details described in the project owner's approved construction specifications, that are not LORS jurisdictional requirements, that are observed during construction inspections to deviate from the project owner's specification but still comply with applicable LORS and do not jeopardize the design in any way, should be communicated to the project owner by the DCBO. However, the DCBO has no further enforcement relative to these project owner options. It is the responsibility of the project owner to ensure their construction firm builds the plant according to these optional specifications and all applicable LORS. The DCBO is tasked with insuring compliance with the LORS only; if the project owner's requirements exceed the minimum requirements posed by the applicable LORS, the DCBO should note the deviation, but not reject the work.

For example, a project owner is required to store liquids (hazardous or combustible) in a container made of material compatible with the liquid stored (NFPA 30, Chapter 21). Unlined concrete is an acceptable tank construction material (NFPA 30 Chapter 4 Section 21.4.1.2 Materials of Construction) provided the liquid stored has an API gravity greater than 40 degrees. Should the project owner decide to coat the inside of this concrete tank, the coating must be compatible with the liquid stored as well. This coating specification will need to be submitted with the tank to demonstrate to the DCBO that the coating is compatible with the liquid stored. The CBSC does not require any coating of a secondary spill containment structure, only that it be liquid tight (CFC Chapter 50, Section 5004 Storage, Paragraph 5004.2.2.1 Containment and drainage methods). If the project owner so desires to coat that secondary containment structure, they may do so. However, if the

project owner does select to coat the secondary containment structure, then the DCBO has the authority to enforce the CBSC to verify that the material stored is compatible (i.e. is not reactive, etc.) with the secondary containment coating. The DCBO should not dictate the type of coating to be used. Neither should the DCBO reject a coating that is different from specified (potentially an availability issue negotiated between construction contractor and owner) unless the coating material is not compatible with the stored material.

If a DCBO has concerns regarding a code interpretation or a response from a project owner, those concerns should be referred to the Energy Commission's CPM for direction.

E2.10 Fire Suppression CFC Compliance – Special Equipment Protection

Fire suppression systems within a power plant are used mostly to extinguish process equipment fires and not occupied buildings. NFPA 850 - Recommended Practice for Electrical Generating Plants and High Voltage Direct Current Converter Stations, NFPA 37 Standard for Installation and Use of Stationary Combustion Engines and Gas Turbines, and NFPA 101 Life Safety Code have been developed to deal with the special fire protection and life safety needs of the power generating plant environment. Even though NFPA 850 is titled a recommended practice, project owners should provide justifications through alternative means when not complying with these recommended practice guidelines as would be the case for alternative methods in the CBSC.

The turbine enclosure's fire protection equipment is custom designed to the specific application and is engineered and constructed to protect the equipment from fire damage as well as water damage. These fire protection systems are not specifically addressed in the CFC; however, the CFC does consider "... compliance with applicable standards of the NFPA or other nationally recognized fire safety standards, as approved, shall be deemed as prima facie evidence of compliance with the intent of this code." per Part 1, Section 102.8 Subjects not regulated by this code.

The DCBO should understand the special nature of these engineered systems and not attempt to "fit" them to the language of the CFC when the above NFPA recommended practices, codes, and standards are followed, thereby meeting the intent of the CFC.

Occupied buildings, offices, warehouses, control rooms, laboratories, etc. should be designed and constructed in accordance with the CFC.

If a DCBO has concerns, regarding a code interpretation or a response from a project owner, those concerns should be referred to the Energy Commission's CPM for direction.

E2.11 PE Requirements for Plan Reviewers and DCBO

Per a legal opinion dated August 26, 1994, from the California Board of Registration for Professional Engineers, "The "plan checking" of engineering plans and documents which are submitted to local public agencies and required to be signed and stamped by professional engineers pursuant to the Professional Engineers Act, is required to be conducted under the responsible charge of a registered professional engineer. A plan

checking review which results in a final professional work product or report would necessitate the use of engineering initiative, skill, and independent judgment. Since plan checking involves an evaluation of professional work product whose preparation requires engineering initiative, skill, and independent judgment, it follows that the review of such work product must be done under the responsible charge of a professional engineer as defined by the Professional Engineers Act.” The DCBO shall be certified as a building official by a recognized association, such as the Council of American Building Officials or the International Code Council.

The DCBO should be mindful that a California Registered Fire Protection Engineer (title act only through the Licensing Board) and other titled plan reviewers are considered professional engineers in California but are not qualified or licensed to practice civil, electrical, or mechanical engineering under this title in California per the Professional Engineers Act. California Code of Regulations, Title 16, Division 5, Section 404 Definitions paragraph (m) states *“Fire protection engineering is that branch of professional engineering which requires such education and experience as is necessary to understand the engineering problems relating to the safeguarding of life and property from fire and fire-related hazards: and requires the ability to apply this knowledge to the identification evaluation, correction, or prevention of present or potential fire and fire related panic hazards in buildings, groups of buildings, or communities, and to recommend the arrangement and use of fire resistant building materials and fire detection and extinguishing systems, devices, and apparatus in order to protect life and property. The above definition of fire protection engineering shall not be construed to permit the practice of civil, electrical, or mechanical engineering.”* The reviews performed by a Registered Fire Protection Engineer and other title act only registrations should be performed under the responsible charge/supervision of a California Registered Professional Civil, Mechanical, or Electrical Engineer, as is appropriate for the review material.

E2.12 Qualification of Steel Fabricators Prior to Start of Work

The DCBO should assist the project owner by communicating to them early in the procurement/design process that the fabrication of structural steel involves the continuous inspection of that fabrication according to the requirements set forth in CBC Chapter 17, Section 1701 Special Inspection. As an alternative to this continuous inspection, the project owner may opt to obtain an “approved fabricator” certification from the DCBO (Section 1704.2.5). However, it should be noted that the project owner does not have any authority to certify any steel fabricator as an approved fabricator; this authority resides with the DCBO.

The DCBO should communicate to the project owner that there have been significant issues with other project owner’s beginning their procurement of major steel structural components (offsite fabrication of the heat recovery steam generator (HRSG) for example) without obtaining the required DCBO approvals of the fabricator or without continuous special inspections during fabrication. The majority of the issues have involved the discovery of structural weld failures late in the fabrication process, by either the project owner or the DCBO. These discoveries have resulted in costly rework and

scheduling delays.

E2.13 Process Piping Hydrostatic Testing

The appropriate ASME piping code defines the hydrostatic testing requirements for all process piping. Not all ASME Codes have the same hydrostatic testing requirements. The DCBO should not require the project owner to test process-piping systems according to the requirements of the CPC or CMC. In the case of natural gas pipeline systems, hydrostatic or pneumatic testing of these pipelines according to the requirements of the CPC would not satisfy the requirements of the ASME B31.8 or USDOT 49 CFR Part 192 for hydrostatic testing.

E2.14 Chemical Spacing – Setbacks within Plant

The CBSC is very specific regarding the spacing of adjacent buildings and equipment, including distances to property boundaries when thresholds of exempted stored quantities of chemicals are exceeded. The Project property boundary is just that – a property boundary. The DCBO should not artificially place “dummy” property boundaries within the plant that effectively double the required spacing between adjacent buildings and equipment. When two adjoining chemical hazard areas are required by the CBSC to have different setbacks to adjoining structures/areas, the greater of the two should control the spacing; these distances are not intended to be additive.

The requirements of Chapter 5, Section 506.3 should not be ignored when applicable in determining the required wall and opening protection for buildings.

E2.15 Process Piping Material QA/QC – ASME Code Requirements

The material QA/QC process for the ASME codes is somewhat more stringent than the CBSC. The material may conform to any number of pipe / fittings material specifications. This is typically demonstrated with written mill certifications (mill cert) that accompany the material. These mill cert documents provide data on specific piping material, obtained through testing, that substantiate compliance with a particular specification. This includes the composition of the material and its tested strength. Labeling of the pipe must be linked in some manner to a lot or “mill run” identification number, which in turn corresponds with the identification number on the mill cert. The labeling of the pipe is often simply a painted identification on the inside⁸ or outside of the pipe joint. This labeling typically includes pipe specification, diameter, wall thickness, mill identification number, etc.

When a joint of pipe is cut into smaller pieces for field fabrication, the labeling is typically transferred (if not to be immediately used in fabrication) to the unmarked segments of

⁸ When pipe is externally coated by a third-party coating mill, it is extremely important that the coating mill transfer the pipe identification marks typically painted on the outside of the pipe to the inside of the pipe prior to the application of the external coating. This transfer of identification markings is the only way to verify material specifications during the construction/fabrication process. The coating mill must have a QA/QC process in place to maintain the identity of the pipe.

pipe so that the proper identity of the material can be maintained. This is because the visual properties of low strength steel are the same as a high strength pipe or pipe with differing metallurgy. Pipe of one specification used in the incorrect service can have disastrous consequences.

This material tracking process must be maintained by the project and periodically audited by the DCBO. It is the intent of the Energy Commission that the DCBO ensure that the project owner has a process in place to verify and track material from procurement to fabrication. The DCBO auditing of this process should not include a requirement that the project provide submittals to the DCBO for review and approval prior to the start of fabrication.

The material tracking process for fittings is somewhat less involved. The fittings are typically stamped individually by the manufacturer, as is common practice and are used as individual units.

E2.16 Turbines, Generators, etc. – Equipment Enclosures

A natural gas turbine / generator is often assembled as a PFA. They are typically fully enclosed weatherproof housings for equipment environmental protection and for noise abatement. The DCBO shall refer to E4.1 regarding PFA guidance. These are not normally occupied spaces and shall be considered equipment enclosures. They often contain internal lubrication oil tanks mounted within a sub-floor structure. Because of the unique operating environment, NFPA 850 – Recommended Practice for Fire Protection for Electrical Generating Plants and High Voltage Direct Current Converter Station should be the primary fire-protection guidance document for design and DCBO review.

Should the PFA containing the combustion turbine be a component of a larger modular structure, a more stringent DCBO structural review may be warranted. For example:

- Where the PFA is designed as the base structural module supporting other structures / modules above the enclosure;
- Where the PFA is the primary supporting structure for a large, concentrated mass where seismic loads would impose large additional loads on the PFA; or
- Where the PFA is designed to support overhead worker access walkways used on a daily basis for access to other equipment in the plant.
- This does not change the NFPA 850 basis of review for fire protection.

E2.17 DCBO and Local Fire Authority Having Response Jurisdiction – Interaction

There may be instances where the local fire department wishes to assume the authority to enforce the CFC for the project's fire protection system design review, inspection, and approval. In these instances, the Energy Commission desires that the DCBO maintain complete oversight and authority for all design reviews, inspections, and approvals,

regardless of the entity performing those reviews, inspections, and approvals.

The DCBO should intercede when the project owner is not supplying timely submittals to the local agency.

The DCBO should not allow any systems, or portions of the plant, to operate that do not have adequate fire protection systems in place (or an approved equivalent protection) that have been reviewed, inspected, tested and approved by the proper authorities.

In cases where the local fire authority lacks expertise in large plant fire protection systems, the DCBO should assist with the review and inspection work to ensure that the fire protection systems comply with applicable LORS. In some cases, this may require the DCBO to perform independent design reviews and inspections.

E2.18 ADA vs. CalOSHA/Federal OSHA Handrails and Platforms

The process areas within a combined-cycle power plant are classified as an industrial process plant. These areas are not accessible to the public. Employees with disabilities do not occupy these areas. Personnel access and protection, in regard to stairways, platforms, mechanical guards, handrails, etc. should comply with the requirements of OSHA and Cal/OSHA. These facilities should not be reviewed from the standpoint of compliance with the CBSC Americans with Disabilities Act (ADA) requirements.

When a power plant includes offices and warehouses, these buildings should be designed to accommodate individuals with certain physical limitations. As a result, these facilities should be designed and reviewed for compliance with the CBSC ADA requirements.

E2.19 Liquid Storage

A project owner is required to store liquids (hazardous or combustible) in a container whose material is compatible with the liquid stored (CFC Chapter 57, Section 5704). If a DCBO has concerns, regarding a code interpretation or a response from a project owner, those concerns should be referred to the Energy Commission's CPM for direction.

E2.20 Temporary Facilities

CBC Volume 1 & 2, Section 202 defines Temporary to mean, ***“buildings and facilities intended for use at one location for not more than one year and seats intended for use at one location for not more than 90 days.”*** CBC Volume 1 & 2, Section 107 states ***“The building official is authorized to issue a permit for temporary structures and temporary uses. Such permits shall be limited as to time of service but shall not be permitted for more than 180 days. The building official is authorized to grant extensions for demonstrated cause.”*** Installations of prefabricated office complexes will typically be on-site for more than one year and are considered permanent. Tents, canopies, membrane structures are all governed structures by the CBSC. Ingress, egress, fire protection, electrical and other code requirements apply.

E2.21 Consistent Application of Importance Factors

Some DCBOs have required designers to utilize a blanket importance factor within a power plant regardless of the essential nature of the individual building and non-building structures. Buildings/structures that are essential to the operation of the power plant have an Occupancy Category IV⁹ thus a higher importance factor. Warehouses, garages, offices, and other similar structures that are not essential to the operation do not warrant Occupancy Category IV and should be Occupancy Category III. ASCE 7-22, Chapter 1 – General, Section 1.5.2 – Multiple Risk Categories, defines that where buildings or other structures are divided into portions with independent structural systems, the classification (Risk Category/Importance Factor) shall be permitted to be determined independently.

ASCE 7-22, Chapter 11 – Seismic Design Criteria, Section 11.5-1 – Importance Factors defines a building and other structure’s seismic Importance Factor (I_e) based on Occupancy Category that shall be assigned to each building and structure in accordance with Table 1.5-2. ASCE 7-22, Chapter 26 – Wind Loads, Section 26.5.1 – Basic Wind Speed, V , used in the determination of design wind loads on buildings and other structures shall be determined from ASCE Figures 26.5-1.

Solar Thermal/Photovoltaic Module/Panels – Seismic $I_e = 1.25$

Category III – Seismic $I_e = 1.25$

Category IV – Seismic $I_e = 1.5$

ASCE 7-22, Chapter 13 – Seismic Design Requirements for Nonstructural Component, (equipment) Section 13.1.3 – Component Importance Factor defines the seismic Importance Factor (I_e) = 1.5 if any of the following four conditions apply:

1. The component is required to function for life-safety purposes after an earthquake, including fire protection sprinkler system and egress stairways.
2. The component conveys, supports, or otherwise contains toxic, highly toxic, or explosive substances where the quantity of the material exceeds a threshold quantity established by the authority having jurisdiction and is sufficient to pose a threat to the public if released.
3. The component is in or attached to a Risk Category IV structure and is needed for continued operation of facility or its failure could impair the continued operation of the facility.
4. The component conveys, supports, or otherwise contains hazardous substances and is attached to a structure or portion thereof classified by the authority having jurisdiction as a

⁹ CBC Table 1604.5 and ASCE 7-22 Table 1.5-1 define occupancy Category of building.

hazardous occupancy.

Otherwise, equipment Importance Factor shall be $I_e = 1.0$.

A project owner may elect the use of importance factors greater than the minimum values presented herein, provided they do not jeopardize the seismic performance of the structural system. In cases where the project owner(s) believes the required minimum values may jeopardize the seismic performance of a structural system, they should present their position to the DCBO.

E2.22 Seismic and Wind Loading of Wind Turbines

The CBSC provides design guidelines for buildings and non-building structures within the state. The CBSC uses a supplemental document published by the American Society of Civil Engineers for determining wind-loading forces on buildings and non-building structures. This document is ASCE 7-22 – Minimum Design Loads for Buildings and Other Structures.

The CBSC was never intended to provide design guidance for machines, such as wind turbines. This is comparable to other similar equipment (radar antenna, satellite earth stations, etc.) found in other industrial building environments whose machine design is not a CBSC jurisdictional process. Wind turbines are machines with turbine blades that rotate due to the kinetic energy of the wind.

Again, buildings/structures that are essential to the operation of the wind turbine power plant have an Occupancy Category IV, thus a higher importance factor. ASCE 7-22, Chapter 1 – General, Section 1.5.2 – Multiple Risk Categories, defines that where buildings or other structures are divided into portions with independent structural systems, the classification (Risk Category/Importance Factor) shall be permitted to be determined independently.

For determining the project's seismic importance factor, ASCE 7-22 shall be assigned to each building and structure in accordance with Table 1.5-2.

The determination of design wind loads on buildings and other structures shall be determined from ASCE 7-22, Figures 26.5-1. However, location-specific basic wind speeds shall be permitted to be determined using the ASCE Wind Design Geodatabase (ASCE Hazard Tool). The database/tool allows users to input the project location, risk factor, and site soil class to look up key design parameters for various load types (wind, seismic, snow, flood) specified in the ASCE standards.

Wind Turbines – Seismic $I_e = 1.25$

Category III – Seismic $I_e = 1.25$

Category IV – Seismic $I_e = 1.5$

E2.23 Wind Loading of Solar Collecting Devices

As described above under **E2.22**, ASCE 7-22 – Minimum Design Loads for Buildings and Other Structures is used for determining wind-loading forces on buildings and non-building structures.

Again, the CBSC was never intended to provide design guidance for machines, which include the solar energy collecting devices (electro-mechanical devices), proposed in all of the solar energy generating power plants. The solar collectors are machines that rotate with the movement of the sun to provide continuous and consistent alignment of the solar collection mirrors with the sun. A number of individual mirrored panels mounted on a support frame comprise these machines.

Although the mirrors have a supporting frame, that frame (and aiming drive mechanism) itself is simply part of that machine and should not be considered a building or non-building structure jurisdictional to the CBSC. Typically, these electro-mechanical machines are designed and built by third-party suppliers. The machines are designed to be assembled and anchored in the field to supporting platforms/foundations designed and installed by the project owner. The foundations, anchorages, and/or machine platforms (defined by the CBC in Section 202) are jurisdictional to the CBSC.

The design of machines (turbines, steam generators, pressure vessels, piping systems, etc.) utilized in power plants are not defined in the CBSC structural requirements. The equipment supports and anchorages of these machines are CBSC jurisdictional. Neither the CBSC, nor ASCE 7-22, was written to establish design standards for these machines. It is not the intent of the CBSC to set machine reliability standards for machines either. These issues are/may be the subject of other industrial codes and practices outside the CBSC.

Project teams should engineer the foundations / equipment supports using sound engineering judgment. Wind loading on the solar collectors should be part of the engineering effort since those forces will be transferred to the equipment supports and anchorages. The DCBO should review the methods employed to ensure some sound methods are employed for determining the wind loading. The DCBO should accept the use of the ASCE 7-22 Chapter 29 Wind Loads on Building Appurtenances and Other Structures: Main Wind Force Resisting System (MFWRS) (Directional Procedure), with respect to Table 29.1-1 – Steps to Determine Wind Loads on MFWRS Other Structures, to determine this loading.

In addition to the wind loading requirements of ASCE 7-22, it is not appropriate to require the mirrors within the solar collectors to be provided with impact resistant material as required for buildings in Section 26.12.3.1 (and others) with ASCE 7-22, unless the following conditions apply:

- Location is within one mile of the coastal mean high-water line where the basic wind speed is equal to or greater than 130 miles/hr., or
- Location area where the basic wind speed is equal to or greater than 140 miles/hr.

Also, the impact resistant material of the solar collectors is a machine reliability issue for

the project and not the CBSC.

The presence of solar energy projects (pilot projects) in California and other states do not indicate that increased design concerns exist for these power generating plants. The lack of widespread concerns from notable failures, regarding the safe operation of these plants, does not indicate the need for extraordinary design measures to be taken.

E2.24 Solar Electric Generating Stations – Occupancy Category

Chapter 31 – Special Constructions, with respect to Section 3111 – Solar Energy Systems provides requirements of the California Building Codes where part of the requirements in Chapter 16 – Structural Design includes the assignment of an occupancy category. These categories are defined within Table 1604.5 – Occupancy Category of Buildings and Other Structures. As the category number increases, the structural design requirements get more complex. Occupancy categories define the nature of the use of a building or non-building structure. Category III defines the use of an occupancy to include power generating stations. Category IV defines the nature of use of an occupancy to include power generating stations that are required as emergency backup facilities for other Occupancy Category IV structures. These other Category IV structures include hospitals, fire and police stations, etc.

Both solar thermal and solar photovoltaic (PV) power plants generate electricity by converting solar irradiance (radiant energy) from the sun to electricity. The chief difference between these two technologies is that the solar thermal technology uses high temperature, high pressure fluids (heat transfer fluid and steam) in the process of this conversion, while the PV technology converts the radiant energy directly to electricity. Solar thermal plants are thus more hazardous than the PV plants. In both cases, though, their respective solar fields are not considered occupant structures by the building code. However, the structural failure of the solar panels in both cases results in the shutdown of the power plant. The adverse impacts on the livability of people and the state's economy due to a shutdown will be potentially significant. Thus, the Energy Commission assigns an Occupancy Category III to solar thermal and PV fields. (Category III defines the use of an occupancy to include nonessential structures within power generating stations.)

The nature of the solar electric generating stations cannot be considered primary or emergency backup for other Occupancy Category IV structures with their limitation of generating power during daylight hours. Solar electric generating stations are intended to provide a supplemental source of electrical power to the existing electrical power grid in California. They are not intended as the primary source of power for hospitals, fire and police departments and should not be as Occupancy Category IV.

DCBO's are not to impose more restrictive occupancy category requirements on solar electric generating stations than is warranted. DCBO's should conduct their plan review for solar electric generating stations as Occupancy Category III classifications. This directly relates to the ASCE 7-22 defined importance factors for seismic design.